

FEATURES

- Single Active Area
- Detection to 1 nm
- Stable Response after Exposure to EUV/UV Conditions
- Protective Cover Plate²

Electro-Optical Characteristics at 25 °C

Parameters	Test Conditions	Min	Typ	Max	Units
Active Area	10 mm x 10 mm		100		mm ²
Responsivity	(see graph on next page)				A/W
Shunt Resistance, Rsh	@ ± 10 mV	10			MOhms
Reverse Breakdown Voltage, V _R	I _R = μA	10			Volts
Capacitance, C	V _R = 0 V		6	15	nF
Response Time, tr	RL = 50 Ω, V _R = 8 V			6	μ sec

Thermal Parameters

Storage and Operating Temperature Range	
Ambient	-10 ° to 40 °C
Nitrogen or Vacuum	-20 °C to 80 °C
Maximum Junction Temperature	70 °C
Lead Soldering Temperature ¹	260 °C

¹ 0.080" from case for 10 seconds.

² Shipped with temporary cover to protect the photodiode and wire bonds.
 Review the Application Note, "Handling Precautions for AXUV, SXUV, and UVG Detectors", prior to removing cover.

Typical Photon Responsivity

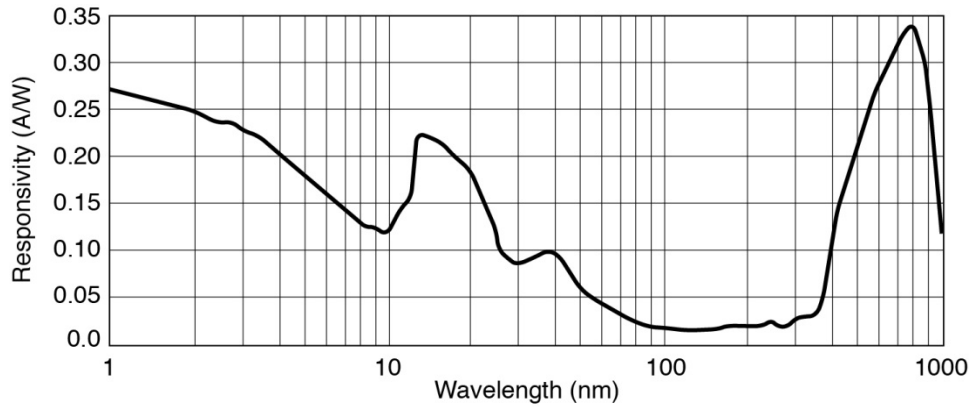

Package Information

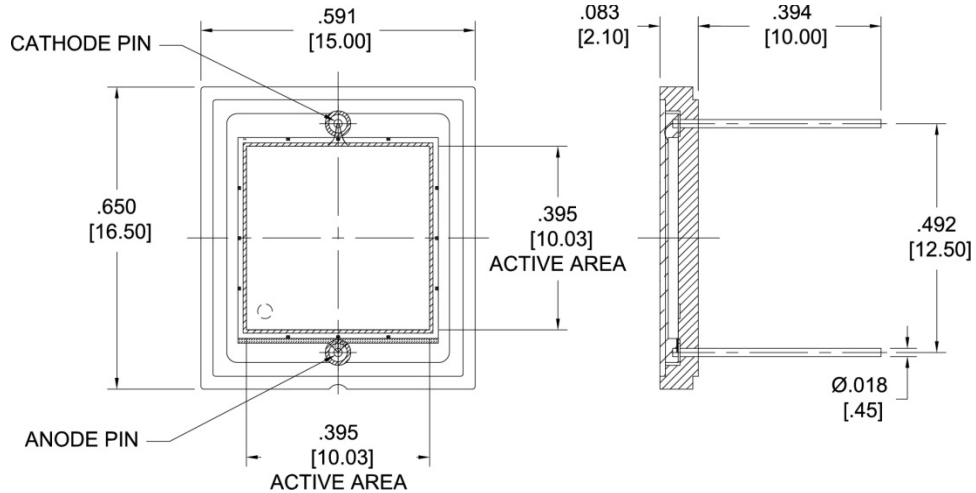

Dimensions are in inch [metric] units.

Ordering Information

ODD-SXU-001 Large EUV Photodetector Shipped with Protective Cover

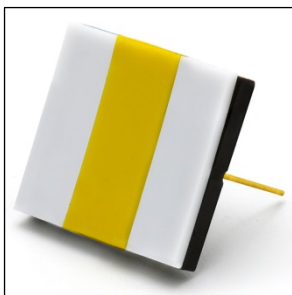

Specifications are subject to change without prior notice.