

TSD SERIES SINGLE OUTPUT DC TO DC CONVERTERS

25-150 Watts
RUGGED CONSTRUCTION, ENCLOSED

APPLICATIONS

The TSD family of DC-DC Converters was designed to satisfy a market for low, cost high reliability applications. The TSD series is especially suitable for critical telcom, medical, automotive and robotic applications. Most models in stock and immediate delivery. Rack mount or custom configurations available.

STANDARD FEATURES

- Compact, Light Weight
- Tightly Regulated Output
- OV/OL/OT Protected
- Terminal Block Connection
- LED Indicator Output Power Good
- $\pm 5\%$ Output Adjustment
- Output Isolated
- MTBF >250,000 Hours
- Meets FCC Docket 20780
- Level A and VDE 0871/6.78 Level A
- UL1950, CSA, 22.2
- Meets NEBS

AVAILABLE OPTIONS

- Parallel Operation
- Redundant Operation (N+1)
- Ruggedized for Severe Environment
- Conformal Coating
- Rack/Panel Mount
- Low Voltage Battery Disconnect

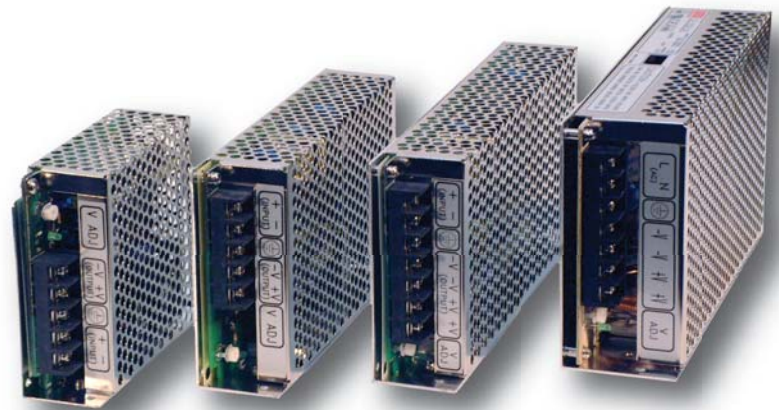

SPECIFICATIONS

ELECTRICAL

Input: 9-18 VDC (A), 18-36 VDC (B),
36-72 VDC (C) or 72-144 VDC(D)

Line Regulation: $\pm .5\%$

Load Regulation: $\pm .5\%$

Ripple: 1% peak to peak, not to exceed 100mV

Efficiency: 80% typical

Hold Up Time: 20ms (minimum)

Protection: OV, OL and OT

MECHANICAL & ENVIRONMENTAL

Operating Temperature: 0°C to +55°C (standard)

Storage Temperature: -40°C to +85°C

Cooling: Convection Cooled

MODEL SELECTION

MODEL	MAX OP	DC INPUT (V)	DC INPUT RATING (A)			ORDER INFORMATION	FIG.
	(WATTS)		+5V	+12V	+24V		
TSD-25 □ - □ □	25	12.24.48	5	2.1	1.1	TSD- 50 [A]-1 [2] Input Voltage — A: 9-18VDC — B: 19-36VDC — C: 36-72VDC — D: 72-144VDC Output Voltage — 05: 4.5-55V — 12: 11-6V — 24: 23-30V	A
TSD-50 □ - □ □	50	12.24.48	10	4.2	2.1		B
TSD-100 □ - □ □	100	24.48.96	20	8.5	4.2		C
TSD-150 □ - □ □	150	24.48.96	N/A	12.5	6.3		D

MECHANICAL OUTLINE

Fig.A

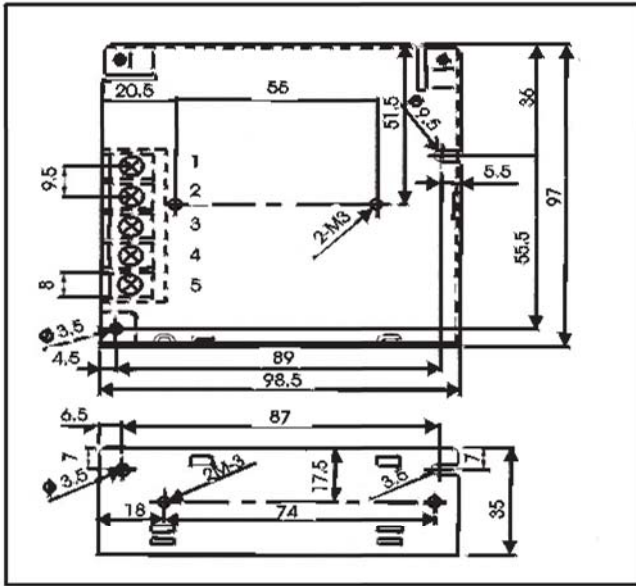

Fig.B

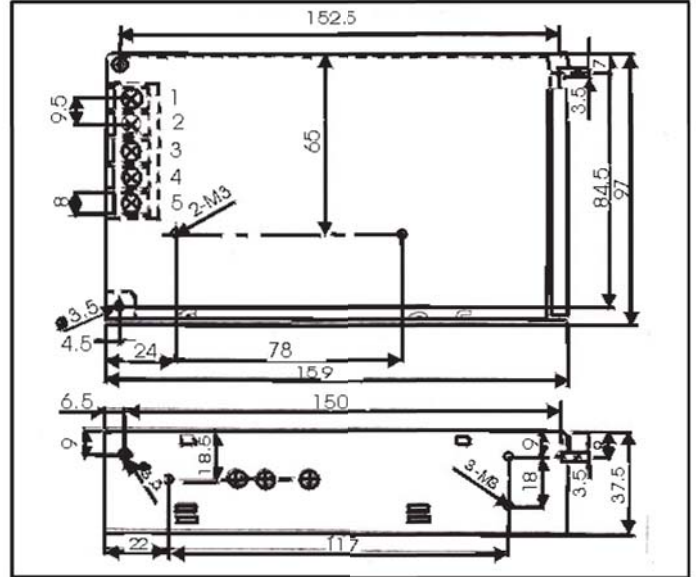

Fig.C

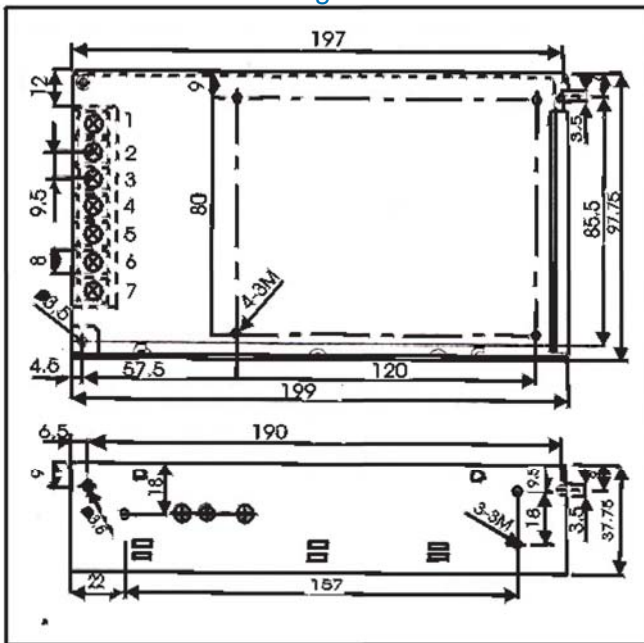

Fig.D

