

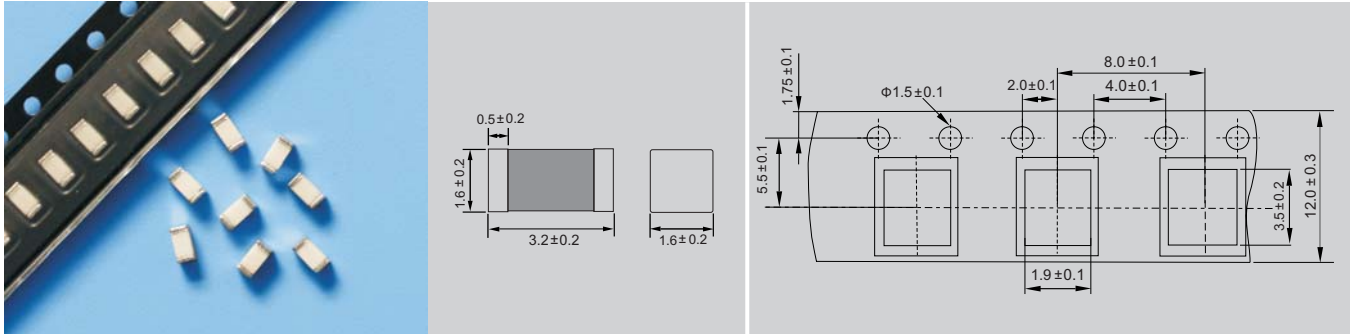

Leiditech

陶瓷气体放电管 Ceramic Gas Discharge Tube



| 目录编号 Catalog No. | 直流击穿电压 DC Spark Over Voltage (100v/s)V | 冲击击穿电压 Impulse Spark Over Voltage (1kv/μs)V | 绝缘电阻 Insulation Resistance MΩ | 极间电容 Electrode Capacitance 1MHz 0.5V PF | 耐冲击电流 Impulse Discharge Current (8/20μs 10 times) | 耐交流电流 AC Discharge Current (50Hz 1s 10 times) A | 过保持电压 Holdover Voltage (V) |
|---------------------|---|--|--|--|--|--|-------------------------------------|
| SMD3216-075N | 75±30% | ≤500 | ≥100 | ≤1 | 0.5KA | 1A | 52 |
| SMD3216-090N | 90±30% | ≤500 | ≥100 | ≤1 | 0.5KA | 1A | 52 |
| SMD3216-140N | 140±30% | ≤600 | ≥100 | ≤1 | 0.5KA | 1A | 52 |
| SMD3216-150N | 150±30% | ≤600 | ≥100 | ≤1 | 0.5KA | 1A | 52 |
| SMD3216-200N | 200±20% | ≤600 | ≥100 | ≤1 | 0.5KA | 1A | 52 |
| SMD3216-230N | 230±20% | ≤600 | ≥100 | ≤1 | 0.5KA | 1A | 52 |
| SMD3216-300N | 300±20% | ≤800 | ≥100 | ≤1 | 0.5KA | 1A | 135 |
| SMD3216-350N | 350±20% | ≤800 | ≥100 | ≤1 | 0.5KA | 1A | 135 |
| SMD3216-400N | 400±20% | ≤900 | ≥100 | ≤1 | 0.5KA | 1A | 135 |
| SMD3216-470N | 470±20% | ≤900 | ≥100 | ≤1 | 0.5KA | 1A | 135 |
| SMD3216-500N | 500±20% | ≤900 | ≥100 | ≤1 | 0.5KA | 1A | 135 |
| SMD3216-600N | 600±20% | ≤900 | ≥100 | ≤1 | 0.5KA | 1A | 135 |

- 参考执行标准: ITU-T K.12, GB/T9043-2008 《通信设备过电压保护用气体放电管通用技术条件》。
Reference executive standard: ITU-T K.12, GB/T9043-2008 《General Technical Requirements of Gas Discharge Tubes for the Over-voltage protection of telecommunications installations》.
- 耐交流 (50 Hz) 电流最大1A, 试验时交流电压应大于直流击穿电压上限值。
The maximum AC withstand current (50 Hz) is 1A and AC voltage shall be larger than the upper limit value of DC spark-over voltage during the test.
- 极间电容测试频率为1M Hz, 测试电压为0.5V。
The electrode capacitance test frequency is 1MHz and test voltage is 0.5V.

工作与储存温度 Operating and Storage temperature
-40°C ~ 85°C

包装 Packaging
产品采用编带卷盘包装, 2500PCS/盘, 每包装箱包装25000PCS。
Automaton taped 2500PCS per reel, 25000PCS per carton.