

# LL3-DH08

LL3

FIBER-OPTIC SENSORS AND FIBERS

**SICK**  
Sensor Intelligence.

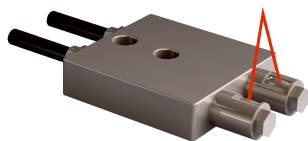

### Ordering information

Type	Part no.
LL3-DH08	5326025

Other models and accessories → [www.sick.com/LL3](http://www.sick.com/LL3)

### Detailed technical data

#### Features

<b>Device type</b>	Fibers
<b>Detection principle</b>	Proximity system
<b>For fiber-optic sensor</b>	GLL170(T), WLL180T, WLL24 Ex
<b>Fiber length</b>	2 m
<b>Fiber material</b>	Silicium (Si)
<b>Jacket material</b>	Perfluoralkoxy-Polymere (PFA)
<b>Fiber head material</b>	Stainless steel
<b>Outer diameter, fiber-optic cable connection</b>	2.2 mm
<b>Fiber-optic cable cuttable</b>	✓ <sup>1)</sup>
<b>Fiber-optic head design</b>	Flat type
<b>Fiber arrangement</b>	Monofiber
<b>Core structure</b>	2 x Ø 1,5 mm Monofiber
<b>Bend radius, fibre-optic cable</b>	25 mm
<b>Compatibility with infrared light (1,450 nm)</b>	Yes
<b>Ambient operating temperature</b>	-60 °C ... +180 °C
<b>Application</b>	Lcd / clear material / semiconductor
<b>Highly flexible/elastic fibers (bend radius 1–4 mm)</b>	No
<b>Adapter end sleeves required</b>	No
<b>Minimal object diameter</b>	0.02 mm <sup>2)</sup>
<b>Compatibility tip adapters</b>	No

<sup>1)</sup> FC fiber optic cable cutter included in delivery.

<sup>2)</sup> Minimum detectable object was determined at optimum measuring distance and optimum setting.

#### Classifications

<b>ECl@ss 5.0</b>	27270905
<b>ECl@ss 5.1.4</b>	27270905
<b>ECl@ss 6.0</b>	27270905
<b>ECl@ss 6.2</b>	27270905
<b>ECl@ss 7.0</b>	27270905
<b>ECl@ss 8.0</b>	27270905
<b>ECl@ss 8.1</b>	27270905
<b>ECl@ss 9.0</b>	27270905

<b>ETIM 5.0</b>	EC002651
<b>ETIM 6.0</b>	EC002651
<b>UNSPSC 16.0901</b>	39121528

Sensing ranges with WLL180T

<b>Operating mode 16 µs</b>	2 mm ... 5 mm
<b>Operating mode 70 µs</b>	0 mm ... 11 mm
<b>Operating mode 250 µs</b>	0 mm ... 22 mm
<b>Operating mode 2 ms</b>	0 mm ... 30 mm
<b>Operating mode 8 ms</b>	0 mm ... 38 mm

Sensing ranges with GLL170

<b>Operating mode 250 µs</b>	7 mm
------------------------------	------

Sensing ranges with GLL170T

<b>Operating mode 50 µs</b>	6 mm
<b>Operating mode 250 µs</b>	12 mm

**Dimensional drawing** (Dimensions in mm (inch))

LL3-DH08

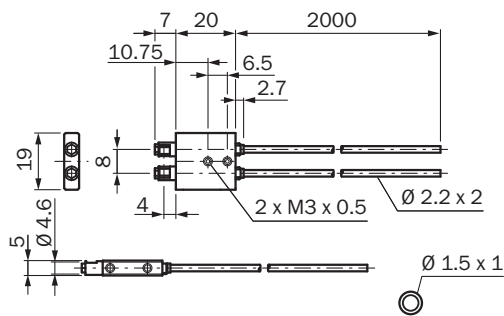

## SICK AT A GLANCE

SICK is one of the leading manufacturers of intelligent sensors and sensor solutions for industrial applications. A unique range of products and services creates the perfect basis for controlling processes securely and efficiently, protecting individuals from accidents and preventing damage to the environment.

We have extensive experience in a wide range of industries and understand their processes and requirements. With intelligent sensors, we can deliver exactly what our customers need. In application centers in Europe, Asia and North America, system solutions are tested and optimized in accordance with customer specifications. All this makes us a reliable supplier and development partner.

Comprehensive services complete our offering: SICK LifeTime Services provide support throughout the machine life cycle and ensure safety and productivity.

For us, that is “Sensor Intelligence.”

## WORLDWIDE PRESENCE:

Contacts and other locations –[www.sick.com](http://www.sick.com)