

## Plug-in Signal Conditioners M-UNIT

### PULSE SCALER

(field-configurable)

#### Functions & Features

- Converting pulse rate into convenient engineering unit for display on a totalizing counter or meter
- Excitation
- Digital scaling accuracy
- Scaling factor adjustable of  $0.9999 \times 10^0$  to  $0.0001 \times 10^{-6}$
- High-density mounting

#### Typical Applications

- Positive displacement flowmeters and turbine flowmeters
- Magnetic tachometers

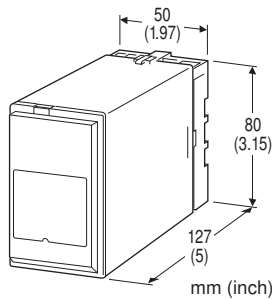

## MODEL: PRU-[1][2]-[3][4]

### ORDERING INFORMATION

- Code number: PRU-[1][2]-[3][4]
- Specify a code from below for each of [1] through [4].  
(e.g. PRU-11-B/Q)
- Input frequency range (e.g. 0 - 356.7 Hz)
  - Output frequency range (e.g. 0 - 1.00 Hz)
  - Specify the specification for option code /Q  
(e.g. /C01/S01)

### [1] INPUT

- 1: Dry contact (Excitation 12 V @30 mA)
  - 2: DISCONTINUED, replaced with code 8
- Voltage pulse; square wave (Excitation 12 V @30 mA)
- 7: Sine wave (Excitation 12 V @30 mA)
  - 8: Voltage pulse; square wave (Excitation 12 V @30 mA)

### [2] OUTPUT

- 1: Open collector (max. frequency 20 kHz)
- 2: 5 V pulse (max. frequency 20 kHz)
- 3: Relay contact (max. frequency 2 Hz)
- 4: 24 V pulse (max. frequency 20 Hz)

### [3] POWER INPUT

#### AC Power

- B: 100 V AC
- C: 110 V AC
- D: 115 V AC
- F: 120 V AC
- G: 200 V AC
- H: 220 V AC
- J: 240 V AC

#### DC Power

- S: 12 V DC
- R: 24 V DC
- V: 48 V DC

### [4] OPTIONS

blank: none

/Q: With options (specify the specification)

### SPECIFICATIONS OF OPTION: Q (multiple selections)

#### COATING (For the detail, refer to M-System's web site.)

- /C01: Silicone coating
- /C02: Polyurethane coating
- /C03: Rubber coating

#### TERMINAL SCREW MATERIAL

- /S01: Stainless steel

### CAUTION

- 1) This unit's output waveform is not uniform due to its scaling method. The user must be aware that it may be inconvenient for certain types of application.
- 2) This unit is designed to accept at the maximum of 100 kHz, which may cause errors due to chattering in the input pulses.  
Use input relays which do not cause chattering (e.g. mercury relays). Other relays could be used only with a CR filter, for 10 Hz at maximum.
- 3) Use M-System's Model M2PRU instead of this unit in conjunction with the pulse output from M-System's power transducers.

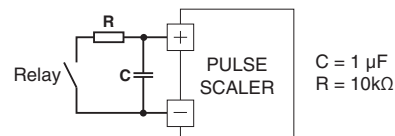

### GENERAL SPECIFICATIONS

**Construction:** Plug-in

**Connection:** M3.5 screw terminals

**Screw terminal:** Chromated steel (standard) or stainless steel

**Housing material:** Flame-resistant resin (black)

**Isolation:** Input to output to power

**Input pulse sensing:** Capacitor coupled; detecting pulse rise

**Sensitivity adjustment:** For voltage pulse input, sine wave input, adjustable between 25 mVp-p - 5 Vp-p (front)

**Scaling factor adjustment:**  $0.9999 \times 10^0 - 0.0001 \times 10^{-6}$   
(front 10-position rotary switch)

**Output pulse width adjustment:** (front)

- Open collector, 5 V pulse: 40  $\mu$ sec. - 0.8 msec.
- Relay contact, 24 V pulse: 40 msec. - 0.8 sec.

## INPUT SPECIFICATIONS

**Excitation:** 12 V DC @30 mA; shortcircuit protection

■ **Dry Contact:** Mechanical contact or open collector

**Max. frequency:** 100 kHz

**Pulse width time requirement:** 5  $\mu$ sec. min. (20 msec. min. for frequencies  $\leq$  10 Hz)

**Sensing:** Approx. 7.5 V DC @ 1 mA

**ON/OFF level:**  $\leq$  20 k $\Omega$  for ON,  $\geq$  100 k $\Omega$  for OFF

■ **Voltage Pulse:** Square or similar waveform

**Max. frequency:** 100 kHz

**Pulse width time requirement:** 5  $\mu$ sec. min. (20 msec. min. for frequencies  $\leq$  10 Hz)

**Input amplitude:** 25 mVp-p - 50 Vp-p

**Minimum amplitude requirement:**

[Pulse Width (Frequency): Amplitude]

$\geq$  250  $\mu$ sec. (0 - 2 kHz): 25 mVp-p

$\geq$  25  $\mu$ sec. (0 - 20 kHz): 50 mVp-p

$\geq$  12.5  $\mu$ sec. (0 - 40 kHz): 1 Vp-p

$\geq$  5  $\mu$ sec. 0 - (100 kHz): 5 Vp-p

**Input impedance:**  $\geq$  50 k $\Omega$

■ **Sine wave:** Sine or similar waveform

**Frequency:** 10 Hz - 100 kHz

**Pulse width time requirement:** 5  $\mu$ sec. min. (20 msec. min. for frequencies  $\leq$  10 Hz)

**Input amplitude:** 25 mVp-p - 50 Vp-p

(within 10 Hz - 100 kHz)

**Minimum amplitude requirement:** (Frequency: Amplitude)

0 - 2 kHz: 25 mVp-p

0 - 20 kHz: 50 mVp-p

0 - 40 kHz: 1 Vp-p

0 - 100 kHz: 5 Vp-p

**Input impedance:**  $\geq$  50 k $\Omega$

**Waveform examples**

•Square Waveform

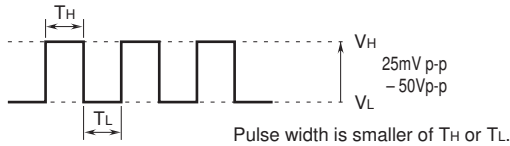

•Sine Waveform

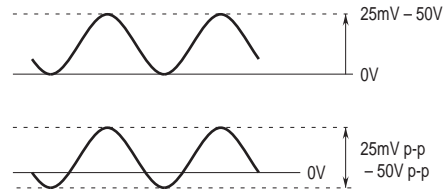

## OUTPUT SPECIFICATIONS

■ **Open Collector:** 50 V DC @ 50 mA (resistive load)

**Frequency range:** 0 - 20 kHz

**ON pulse width:** 40  $\mu$ sec. - 0.8 msec. adjustable

**Saturation voltage:** 0.6 V DC

■ **Relay Contact:** 120 V AC @ 200 mA ( $\cos \theta = 1$ )

240 V AC @ 100 mA ( $\cos \theta = 1$ )

24 V DC @ 200 mA (resistive load)

**Frequency range:** 0 - 2 Hz

**ON pulse width:** 40 msec. - 0.8 sec. adjustable

**Relay life:**

$\geq 5 \times 10^7$  cycles (mechanical)

$\geq 10^5$  cycles (electrical)

■ **5 V Pulse**

**Frequency range:** 0 - 20 kHz

**Low pulse width:** 40  $\mu$ sec. - 0.8 msec. adjustable

**Hi/Lo level:** 5 V  $\pm$  10 % for Hi;  $\leq$  0.5 V for Lo

**Load resistance:** 600  $\Omega$  min.

■ **24 V Pulse**

**Frequency range:** 0 - 20 Hz

**High pulse width:** 40 msec. - 0.8 sec. adjustable

**Hi/Lo level:** 24 V  $\pm$  10 % for Hi;  $\leq$  0.5 V for Lo

**Load current:** 30 mA max.

**Load resistance:** 800  $\Omega$  min.

## INSTALLATION

**Power input**

• **AC:** Operational voltage range: rating  $\pm$ 10 %, 50/60  $\pm$ 2 Hz, approx. 2 VA

• **DC:** Operational voltage range: rating  $\pm$ 10 %, ripple 10 %p-p max., approx. 2 W (80 mA at 24 V)

**Operating temperature:** -5 to +60°C (23 to 140°F)

**Operating humidity:** 30 to 90 %RH (non-condensing)

**Mounting:** Surface or DIN rail

**Weight:** 350 g (0.77 lb)

## PERFORMANCE

**Insulation resistance:**  $\geq$  100 M $\Omega$  with 500 V DC

**Dielectric strength:** 2000 V AC @1 minute (input to output to power to ground)

## EXTERNAL VIEW

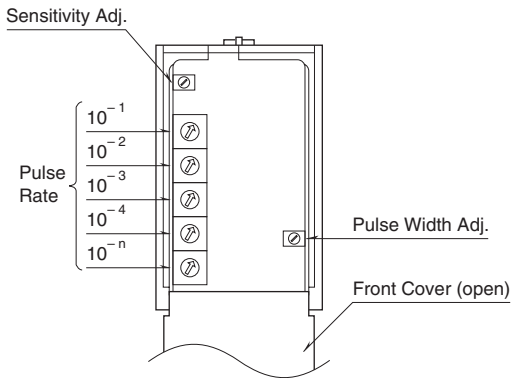

## EXTERNAL DIMENSIONS & TERMINAL ASSIGNMENTS unit: mm (inch)

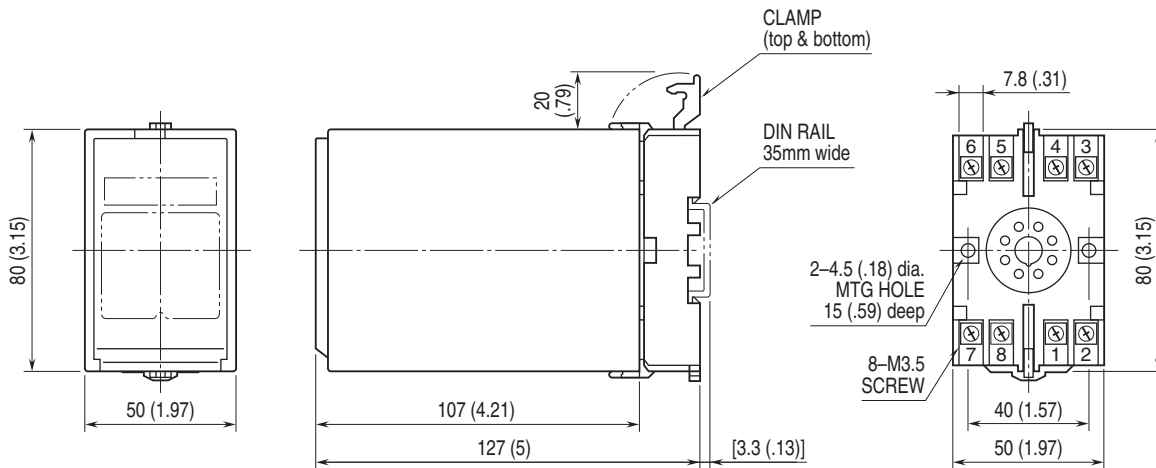

• When mounting, no extra space is needed between units.

## SCHEMATIC CIRCUITRY & CONNECTION DIAGRAM

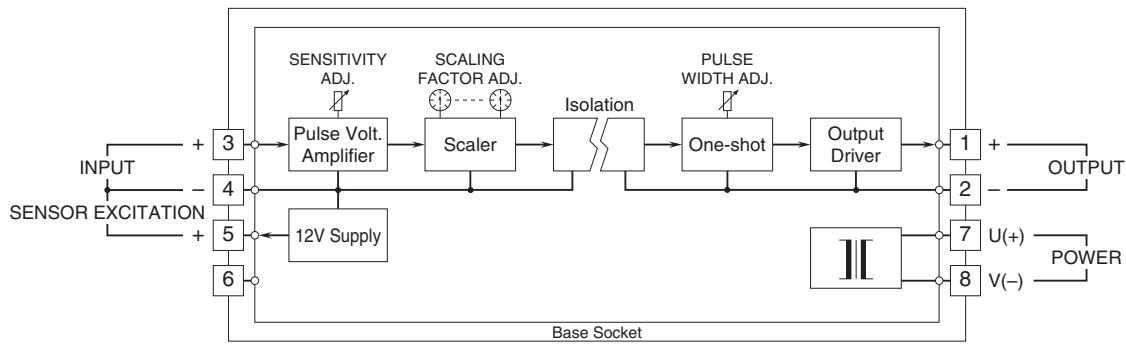

### Input Connection Examples

#### ■ Dry Contact

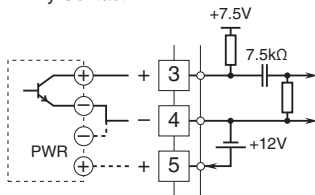

### Output Connection Examples

#### ■ Open Collector

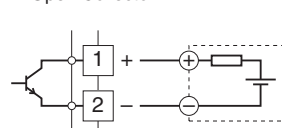

#### ■ Relay Contact • AC Powered

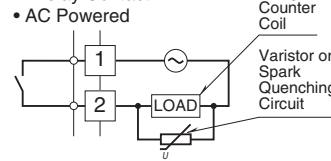

#### • DC Powered

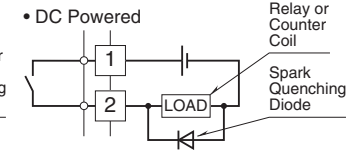

#### ■ Voltage Pulse

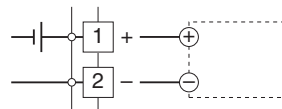

#### ■ Voltage Pulse, Sine Wave

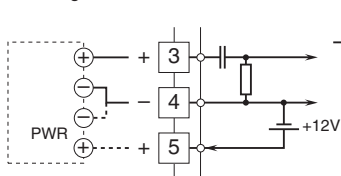

Specifications are subject to change without notice.