

Infineon[®] LITIX[™] Power

H-Bridge DC/DC Controller

H-Bridge DC/DC Controller for High Power LED Lighting

TLD5190QV

Data Sheet

Rev. 1.0, 2016-05-20

Automotive Power

Table of Contents

1	Overview	4
2	Block Diagram	6
3	Pin Configuration	7
3.1	Pin Assignment	7
3.2	Pin Definitions and Functions	8
4	General Product Characteristics	11
4.1	Absolute Maximum Ratings	11
4.2	Functional Range	13
4.3	Thermal Resistance	13
5	Power Supply	15
5.1	Different Power States	17
5.2	Electrical Characteristics	18
6	Regulator Description	19
6.1	Regulator Diagram Description	19
6.2	Adjustable Soft Start Ramp	21
6.3	Switching Frequency setup	21
6.4	Operation of 4 switches H-Bridge architecture	22
6.4.1	Boost mode ($V_{IN} < V_{OUT}$)	22
6.4.2	Buck mode ($V_{IN} > V_{OUT}$)	23
6.4.3	Buck-Boost mode ($V_{IN} \sim V_{OUT}$)	24
6.5	Flexible current sense	25
6.6	Programming Output Voltage (Constant Voltage Regulation)	26
6.7	Electrical Characteristics	27
7	Digital Dimming Function	30
7.1	Description	30
7.2	Electrical Characteristics	32
8	Analog Dimming	33
8.1	Description	33
8.2	Electrical Characteristics	34
9	Linear Regulator	36
9.1	IVCC Description	36
9.2	Electrical Characteristics	37
10	Protection and Diagnostic Functions	38
10.1	Description	38
10.2	Overvoltage, Open Load, Short circuit protection	39
10.2.1	Short Circuit protection	39
10.2.2	Overvoltage Protection	39
10.2.3	Open Load Protection	40
10.3	Input voltage monitoring, protection and power derating	40
10.4	Input current Monitoring	42
10.5	Output current Monitoring	42
10.6	Device Temperature Monitoring	43
10.7	Electrical Characteristics	44
11	Infineon FLAT SPECTRUM Featureset	45
11.1	Description	45

Table of Contents

11.2	Synchronization Function	45
11.3	CLKOUT Function	45
11.4	Spread Spectrum	47
11.5	EMC optimized schematic	48
11.6	Electrical Characteristics	49
12	Application Information	50
12.1	Further Application Information	53
13	Package Outlines	56
14	Revision History	57



1 Overview

Features

- MOSFET H-Bridge with Single Inductor DC/DC Controller for HIGH POWER BUCK-BOOST LED control
- Constant Current and Constant Voltage Regulation
- Wide VIN Range (Device 4.5V to 40V, Power Stage 4.5V to 55V)
- Wide LED forward voltage Range (2V up to 55V)
- Maximum Efficiency in every condition (up to 96%)
- Flexible current sense (Highside or Lowside)
- LED current accuracy +/-3% at Tj=25° and 4% over the whole automotive temperature range
- EMC optimized device: Features an auto Spread Spectrum concept to ensure best in class EMC performance
- Open Load, Overvoltages, Shorted LED fault and Overtemperature Diagnostic Outputs
- LED and Input current sense with dedicated monitor Outputs
- Smart power protection features for device and load (open load, short of Load, Overtemperature)
- Switching Frequency Range from 200 kHz to 700 kHz
- Capability to supply Gate Drivers via external Voltage Regulator
- Adjustable Soft Start
- Enhanced Dimming features to adjust average LED current and PWM dimming
- Available in a small thermally enhanced PG-VQFN-48-31 package
- Automotive AEC Qualified

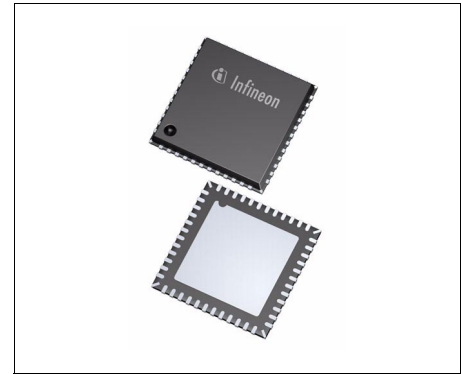

PG-VQFN-48-31

Description

The TLD5190QV is a synchronous MOSFET H-Bridge DC/DC controller with built in protection features. This concept is beneficial for driving high power LEDs with maximum system efficiency and minimum number of external components. The TLD5190QV offers both analog and digital (PWM) dimming. The switching frequency is adjustable in the range of 200 kHz to 700 kHz. It can be synchronized to an external clock source. A built in Spread Spectrum switching frequency modulation and the forced continuous current regulation mode improve the overall EMC behavior. Furthermore the current mode regulation scheme provides a stable regulation loop maintained by small external compensation components. The adjustable soft start feature limits the current peak as well as voltage overshoot at start-up. The TLD5190QV is suitable for use in the harsh automotive environment.

Type	Package	Marking
TLD5190QV	PG-VQFN-48-31	TLD5190QV

Table 1 Product Summary

Power Stage input voltage range	V_{POW}	4.5 V ... 55 V
Device Input supply voltage range	V_{VIN}	4.5 V ... 40 V
Maximum output voltage (depending by the application conditions)	$V_{OUT(max)}$	55 V as LED Driver Boost Mode 50 V as LED Driver Buck Mode 50 V as Voltage regulator
Switching Frequency range,	f_{SW}	200 kHz... 700 kHz
Typical NMOS driver on-state resistance at $T_j = 25^\circ\text{C}$ (Gate Pull Up)	$R_{DS(ON_PU)}$	2.3 Ω
Typical NMOS driver on-state resistance at $T_j = 25^\circ\text{C}$ (Gate Pull Down)	$R_{DS(ON_PD)}$	1.2 Ω

Protective Functions

- Over load protection of external MOSFETs
- Shorted load, open load, output overvoltage protection
- Input overvoltage and undervoltage protection
- Thermal shutdown of device with autorestart behavior
- Electrostatic discharge protection (ESD)

Diagnostic Functions

- Diagnostic information via Error Flags
- Open load detection in ON-state
- Device Overtemperature shutdown
- Advanced diagnostic functions provide I_{LED} and I_{IN} information

Applications

- Especially designed for driving high power LEDs in automotive applications
- Automotive Exterior Lighting: full LED headlamp assemblies (Low Beam, High Beam, Matrix Beam, Pixel Light)
- General purpose current/voltage controlled DC/DC LED driver

2 Block Diagram

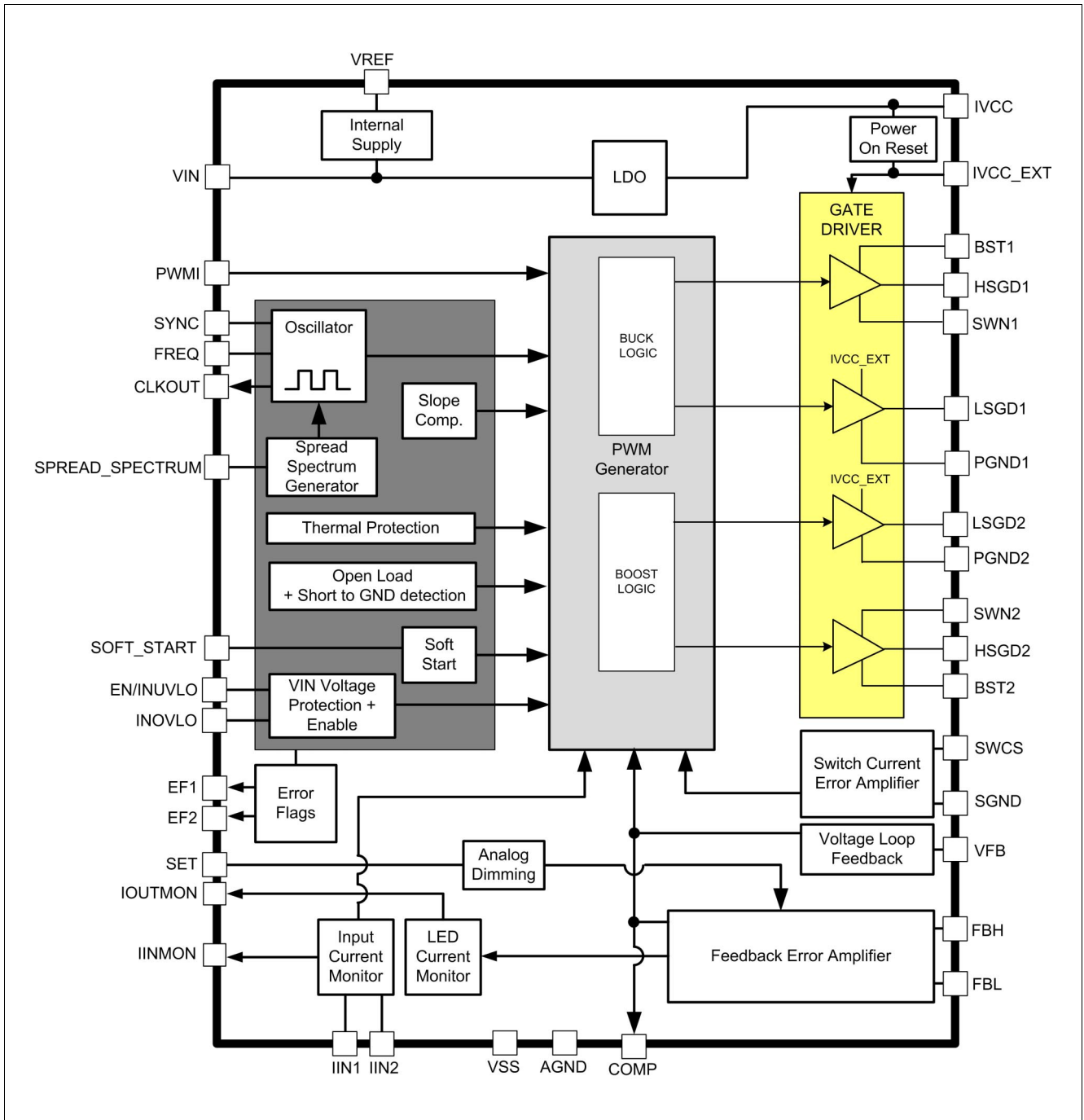

Figure 1 Block Diagram - TLD5190QV

3 Pin Configuration

3.1 Pin Assignment

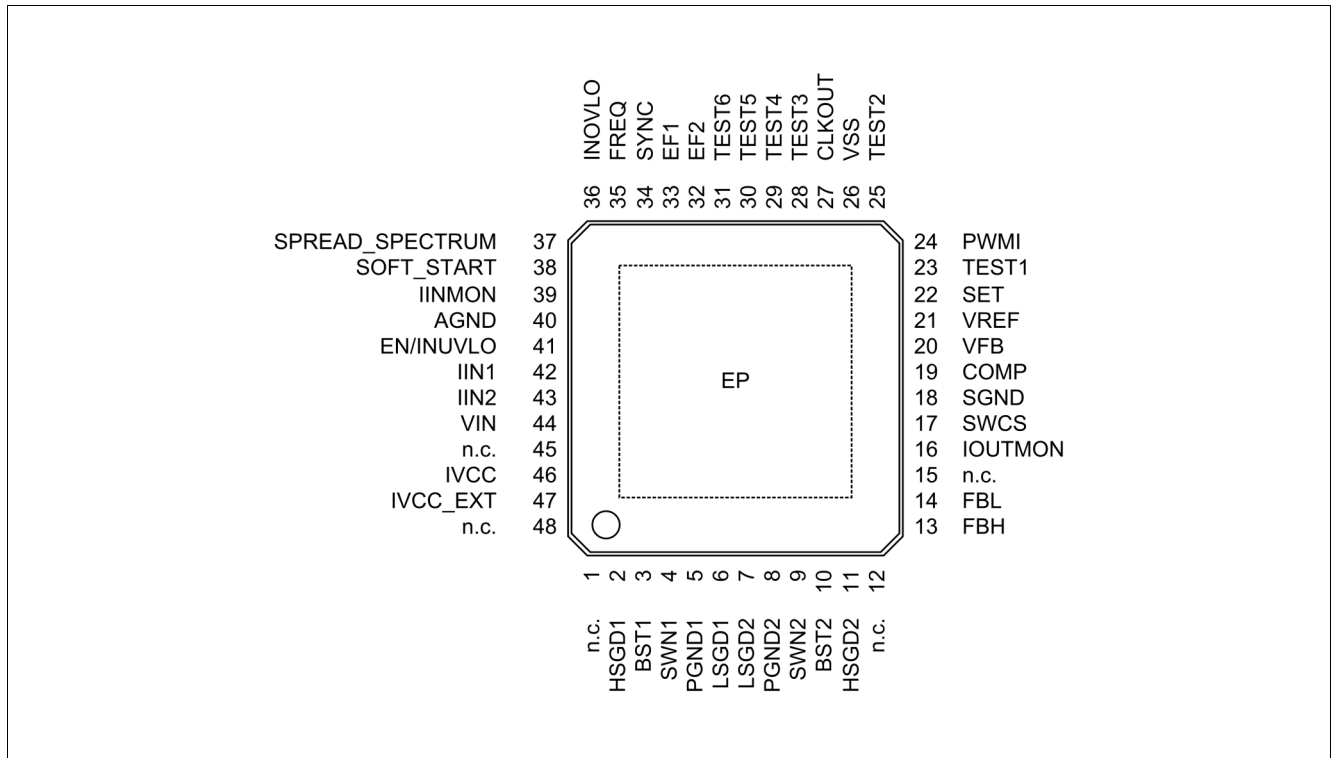

Figure 2 Pin Configuration - TLD5190QV

3.2 Pin Definitions and Functions

Pin	Symbol	I/O ¹⁾		Function
Power Supply				
1, 12, 15, 45, 48	n.c.	-		Not connected, tie to AGND on the Layout;
44	VIN	-		Power Supply Voltage; Supply for internal biasing.
47	IVCC_EXT	I	PD	External LDO input; Input to alternatively supply internal Gate Drivers via an external LDO. Connect to IVCC pin to use internal LDO to supply gate drivers. Must not be left open.
5, 8	PGND1, 2	-		Power Ground; Ground for power potential. Connect externally close to the chip.
26	VSS	-		Digital GPIO Ground; Ground for GPIO pins
40	AGND	-		Analog Ground; Ground Reference
-	EP	-		Exposed Pad; Connect to external heatspreading Cu area (e.g. inner GND layer of multilayer PCB with thermal vias).
Gate Driver Stages				
2	HSGD1	O		Highside Gate Driver Output 1; Drives the top n-channel MOSFET with a voltage equal to V_{IVCC_EXT} superimposed on the switch node voltage SWN1. Connect to gate of external switching MOSFET.
11	HSGD2	O		Highside Gate Driver Output 2; Drives the top n-channel MOSFET with a voltage equal to V_{IVCC_EXT} superimposed on the switch node voltage SWN2. Connect to gate of external switching MOSFET.
6	LSGD1	O		Lowside Gate Driver Output 1; Drives the lowside n-channel MOSFET between GND and V_{IVCC_EXT} Connect to gate of external switching MOSFET.
7	LSGD2	O		Lowside Gate Driver Output 2; Drives the lowside n-channel MOSFET between GND and V_{IVCC_EXT} Connect to gate of external switching MOSFET.
4	SWN1	IO		Switch Node 1; SWN1 pin swings from a diode voltage drop below ground up to V_{IN}
9	SWN2	IO		Switch Node 2; SWN2 pin swings from ground up to a diode voltage drop above V_{OUT}
46	IVCC	O		Internal LDO output; Used for internal biasing and gate driver supply. Bypass with external capacitor close to the pin. Pin must not be left open.
Inputs and Outputs				

Pin Configuration

Pin	Symbol	I/O ¹⁾		Function
23	TEST1	-		Test Pin; Used for Infineon end of line test, connect to GND in application
25	TEST2	-		Test Pin; Used for Infineon end of line test, connect to GND in application
28	TEST3	-		Test Pin; Used for Infineon end of line test, connect to GND in application
29	TEST4	-		Test Pin; Used for Infineon end of line test, connect to GND in application
30	TEST5	-		Test Pin; Used for Infineon end of line test, connect to GND in application
31	TEST6	-		Test Pin; Used for Infineon end of line test, connect to GND in application
41	EN/INUVLO	I	PD	Enable/Input Under Voltage Lock Out; Used to put the device in a low current consumption mode, with additional capability to fix an undervoltage threshold via external components. Pin must not be left open.
35	FREQ	I		Frequency Select Input; Connect external resistor to GND to set frequency.
34	SYNC	I	PD	Synchronization Input; Apply external clock signal for synchronization
24	PWMI	I	PD	Control Input; Digital input 5V or 3.3V.
13	FBH	I		Output current Feedback Positive; Non inverting Input (+)
14	FBL	I		Output current Feedback Negative; Inverting Input (-)
3	BST1	IO		Bootstrap capacitor; Used for internal biasing and to drive the Highside Switch HSGD1. Bypass to SWN1 with external capacitor close to the pin. Pin must not be left open.
10	BST2	IO		Bootstrap capacitor; Used for internal biasing and to drive the Highside Switch HSGD2. Bypass to SWN2 with external capacitor close to the pin. Pin must not be left open.
17	SWCS	I		Current Sense Input; Inductor current measurement - Non Inverting Input (+)
18	SGND	I		Current Sense Ground; Inductor current sense - Inverting Input (-) Route as Differential net with SWCS on the Layout
42	IIN1	I		Input Current Monitor Positive; Non Inverting Input (+), connect to VIN if input current monitor is not needed
43	IIN2	I		Input Current Monitor Negative; Inverting Input (-), connect to VIN if input current monitor is not needed
19	COMP	O		Compensation Network Pin; Connect R and C network to pin for stability phase margin adjustment
38	SOFT_START	O		Softstart configuration Pin; Connect a capacitor C_{SOFT_START} to GND to fix a soft start ramp default time.

Pin Configuration

Pin	Symbol	I/O ¹⁾		Function
36	INOVLO	I		Input Overvoltage Protection Pin; Define an upper voltage threshold and switches OFF the device in case of overvoltages on the VIN supply. Must not be left open.
20	VFB	I		Voltage Loop Feedback Pin; VFB is intended to set output protection functions.
22	SET	I		Analog current sense adjustment Pin; A voltage V_{SET} between 0.2V and 1.5V will adjust the I_{LED} or V_{OUT} in a linear relation.
37	SPREAD_SPECTRUM	I	PD	Spread Spectrum Pin; This pin is enabling and disabling the SPREAD SPECTRUM function. This feature is beneficial to improve the EMC performance.
39	IINMON	O		Input current monitor output; Monitor pin that produces a voltage that is 20 times the voltage $V_{IIN1-IIN2}$. IINMON will be equal 1V when $V_{IIN1}-V_{IIN2}=50mV$
16	IOUTMON	O		Output current monitor output; Monitor pin that produces a voltage that is 200mV + 8 times the voltage $V_{FBH-FBL}$. IOUTMON will be equal 1.4V when $V_{FBH-FBL} = 150mV$.
21	VREF	O	PD	Voltage Reference Output Pin; Supplies an accurate 2V output voltage for standalone analog dimming and LED temperature compensation via external resistors. Bypass with an external 100nF capacitor close to the pin. Pin must not be left open.

Logic Outputs

27	CLKOUT	O		Clock Output Pin; Switching Oscillator output signal to supply additional SYNC Inputs of other DCDC devices (beneficial for standalone operations without μC)
33	EF1	O		Error Flag 1; An open drain output which is pulled to LOW when an output Short to GND or Overtemperature occurs
32	EF2	O		Error Flag 2; An open drain output which is pulled to LOW when an OPEN load, Overvoltages or Overtemperature occurs

1) O: Output, I: Input,
PD: pull-down circuit integrated,
PU: pull-up circuit integrated

4 General Product Characteristics

4.1 Absolute Maximum Ratings

Table 2 Absolute Maximum Ratings¹⁾
 $T_j = -40^\circ\text{C}$ to $+150^\circ\text{C}$; all voltages with respect to AGND, (unless otherwise specified)

Parameter	Symbol	Values			Unit	Note / Test Condition	Number
		Min.	Typ.	Max.			
Supply Voltages							
VIN Supply Input	V_{VIN}	-0.3	–	60	V	–	P_4.1.1
IVCC Internal Linear Voltage Regulator Output voltage	V_{IVCC}	-0.3	–	6	V	–	P_4.1.3
IVCC_EXT External Linear Voltage Regulator Input voltage	V_{IVCC_EXT}	-0.3	–	6	V	–	P_4.1.4
VREF Voltage reference output	V_{REF}	-0.3	–	3.6	V	–	P_4.1.5
Gate Driver Stages							
LSGD1,2 - PGND1,2 Lowside Gatedriver voltage	$V_{LSGD1,2-PGND}$	-0.3	–	5.5	V	–	P_4.1.54
HSGD1,2 - SWN1,2 Highside Gatedriver voltage	$V_{HSGD1,2-SWN1,2}$	-0.3	–	5.5	V	–	P_4.1.55
SWN1, SWN2 switching node voltage	$V_{SWN1, 2}$	-1	–	60	V	–	P_4.1.6
(BST1-SWN1), (BST2-SWN2) Bootstrap voltage	$V_{BSTx-SWNx}$	-0.3	–	6	V	–	P_4.1.7
BST1, BST2 Bootstrap voltage related to GND	$V_{BST1, 2}$	-0.3	–	65	V	–	P_4.1.8
SWCS Switch Current Sense Input voltage	V_{SWCS}	-0.3	–	0.3	V	–	P_4.1.9
SGND Switch Current Sense GND voltage	V_{SGND}	-0.3	–	0.3	V	–	P_4.1.10
SWCS-SGND Switch Current Sense differential voltage	$V_{SWCS-SGND}$	-0.5	–	0.5	V	–	P_4.1.11
PGND1,2 Power GND voltage	$V_{PGND1,2}$	-0.3	–	0.3	V	–	P_4.1.28
High voltage Pins							
IIN1, IIN2 Input Current monitor voltage	$V_{IIN1, 2}$	-0.3	–	60	V	–	P_4.1.12
IIN1-IIN2 Input Current monitor differential voltage	$V_{IIN1-IIN2}$	-0.5	–	0.5	V	–	P_4.1.13

Table 2 Absolute Maximum Ratings¹⁾ (cont'd)
 $T_j = -40^\circ\text{C}$ to $+150^\circ\text{C}$; all voltages with respect to AGND, (unless otherwise specified)

Parameter	Symbol	Values			Unit	Note / Test Condition	Number
		Min.	Typ.	Max.			
FBH, FBL Feedback Error Amplifier voltage	$V_{\text{FBH, FBL}}$	-0.3	–	60	V	–	P_4.1.14
FBH-FBL Feedback Error Amplifier differential voltage	$V_{\text{FBH-FBL}}$	-0.5	–	0.5	V	–	P_4.1.15
EN/INUVLO Device enable/input undervoltage lockout	$V_{\text{EN/INUVLO}}$	-0.3	–	60	V	–	P_4.1.16
Digital (I/O) Pins							
PWMI Digital Input voltage	V_{PWMI}	-0.3	–	5.5	V	–	P_4.1.17
SYNC Synchronization Input voltage	V_{SYNC}	-0.3	–	5.5	V	–	P_4.1.22
CLKOUT Clock Output voltage	V_{CLKOUT}	-0.3	–	5.5	V	–	P_4.1.23
SPREAD_SPECTRUM Spread Spectrum Input voltage	$V_{\text{SPREAD_SPECTRUM}}$	-0.3	–	5.5	V	–	P_4.1.24
Analog Pins							
VFB Loop Input voltage	V_{VFB}	-0.3	–	5.5	V	–	P_4.1.25
INOVLO Input overvoltage lockout	V_{INOVLO}	-0.3	–	5.5	V	–	P_4.1.26
EF1, 2 Error Flags output voltage	$V_{\text{EF1,2}}$	-0.3	–	5.5	V	–	P_4.1.27
SET Analog dimming Input voltage	V_{SET}	-0.3	–	5.5	V	–	P_4.1.29
COMP Compensation Input voltage	V_{COMP}	-0.3	–	3.6	V	–	P_4.1.30
SOFT_START Softstart Voltage	$V_{\text{SOFT_START}}$	-0.3	–	3.6	V	–	P_4.1.31
FREQ Voltage at frequency selection pin	V_{FREQ}	-0.3	–	3.6	V	–	P_4.1.32
IINMON Voltage at input monitor pin	V_{IINMON}	-0.3	–	3.6	V	–	P_4.1.33
IOUTMON Voltage at output monitor pin	V_{IOUTMON}	-0.3	–	5.5	V	–	P_4.1.34
Temperatures							
Junction Temperature	T_j	-40	–	150	°C	–	P_4.1.35
Storage Temperature	T_{stg}	-55	–	150	°C	–	P_4.1.36
ESD Susceptibility							
ESD Resistivity of all Pins	$V_{\text{ESD,HBM}}$	-2	–	2	kV	HBM ²⁾	P_4.1.37

Table 2 Absolute Maximum Ratings¹⁾ (cont'd)
 $T_j = -40^\circ\text{C}$ to $+150^\circ\text{C}$; all voltages with respect to AGND, (unless otherwise specified)

Parameter	Symbol	Values			Unit	Note / Test Condition	Number
		Min.	Typ.	Max.			
ESD Resistivity to GND	$V_{\text{ESD,CDM}}$	-500	–	500	V	CDM ³⁾	P_4.1.38
ESD Resistivity of corner Pins to GND	$V_{\text{ESD,CDM_corner}}$	-750	–	750	V	CDM ³⁾	P_4.1.39

- 1) Not subject to production test, specified by design.
- 2) ESD susceptibility, HBM according to ANSI/ESDA/JEDEC JS001 (1.5k Ω , 100 pF)
- 3) ESD susceptibility, Charged Device Model “CDM” ESDA STM5.3.1 or ANSI/ESD S.5.3.1

Note: Stresses above the ones listed here may cause permanent damage to the device. Exposure to absolute maximum rating conditions for extended periods may affect device reliability.

1. *Integrated protection functions are designed to prevent IC destruction under fault conditions described in the data sheet. Fault conditions are considered as “outside” normal operating range. Protection functions are not designed for continuous repetitive operation.*

4.2 Functional Range

Table 3 Functional Range

Parameter	Symbol	Values			Unit	Note / Test Condition	Number
		Min.	Typ.	Max.			
Device Extended Supply Voltage Range	V_{VIN}	4.5	–	40	V	1)	P_4.2.1
Device Nominal Supply Voltage Range	V_{VIN}	8	–	36	V	–	P_4.2.2
Power Stage Voltage Range	V_{POW}	4.5	–	55	V	1)	P_4.2.5
Junction Temperature	T_j	-40	–	150	$^\circ\text{C}$	–	P_4.2.4

- 1) Not subject to production test, specified by design.

Note: Within the functional range the IC operates as described in the circuit description. The electrical characteristics are specified within the conditions given in the related electrical characteristics table.

4.3 Thermal Resistance

Note: This thermal data was generated in accordance with JEDEC JESD51 standards. For more information, go to www.jedec.org.

Table 4

Parameter	Symbol	Values			Unit	Note / Test Condition	Number
		Min.	Typ.	Max.			
Junction to Case	R_{thJC}	–	0.9	–	K/W	1) 2)	P_4.3.1
Junction to Ambient	R_{thJA}	–	25	–	K/W	3) 2s2p	P_4.3.2

- 1) Not subject to production test, specified by design.

General Product Characteristics

- 2) Specified R_{thJC} value is simulated at natural convection on a cold plate setup (all pins and the exposed pad are fixed to ambient temperature). $T_a=25^\circ\text{C}$; The IC is dissipating 1W.
- 3) Specified R_{thJA} value is according to JEDEC 2s2p (JESD 51-7) + (JESD 51-5) and JEDEC 1s0p (JESD 51-3) + heatsink area at natural convection on FR4 board; The device was simulated on a 76.2 x 114.3 x 1.5 mm board. The 2s2p board has 2 outer copper layers (2 x 70 μm Cu) and 2 inner copper layers (2 x 35 μm Cu). A thermal via (diameter = 0.3 mm and 25 μm plating) array was applied under the exposed pad and connected the first outer layer (top) to the first inner layer and second outer layer (bottom) of the JEDEC PCB. $T_a=25^\circ\text{C}$; The IC is dissipating 1W.

5 Power Supply

The TLD5190QV is supplied by the following pins:

- VIN (main supply voltage)
- IVCC_EXT (supply for internal gate driver stages)

The VIN supply provides internal supply voltages for the analog and digital blocks.

IVCC_EXT is the supply for the low side driver stages. This supply is used also to charge, through external schottky diodes, the bootstrap capacitors which provide supply voltages to the high side driver stages. If no external voltage is available this pin must be shorted to IVCC, which is the output of an internal 5V LDO.

The supply pins VIN and IVCC_EXT have undervoltage detections.

Undervoltage on IVCC_EXT or IVCC voltages forces a deactivation of the driver stages, thus stopping the switching activity.

Moreover the double function pin EN/INUVLO can be used as an input undervoltage protection by placing a resistor divider from VIN to GND (refer to [Chapter 10.3](#)).

If EN/INUVLO undervoltage is detected, it will turn-off the IVCC voltage regulator, and stop switching.

Figure 3 shows a basic concept drawing of the supply domains and interactions among pins VIN and IVCC/IVCC_EXT.

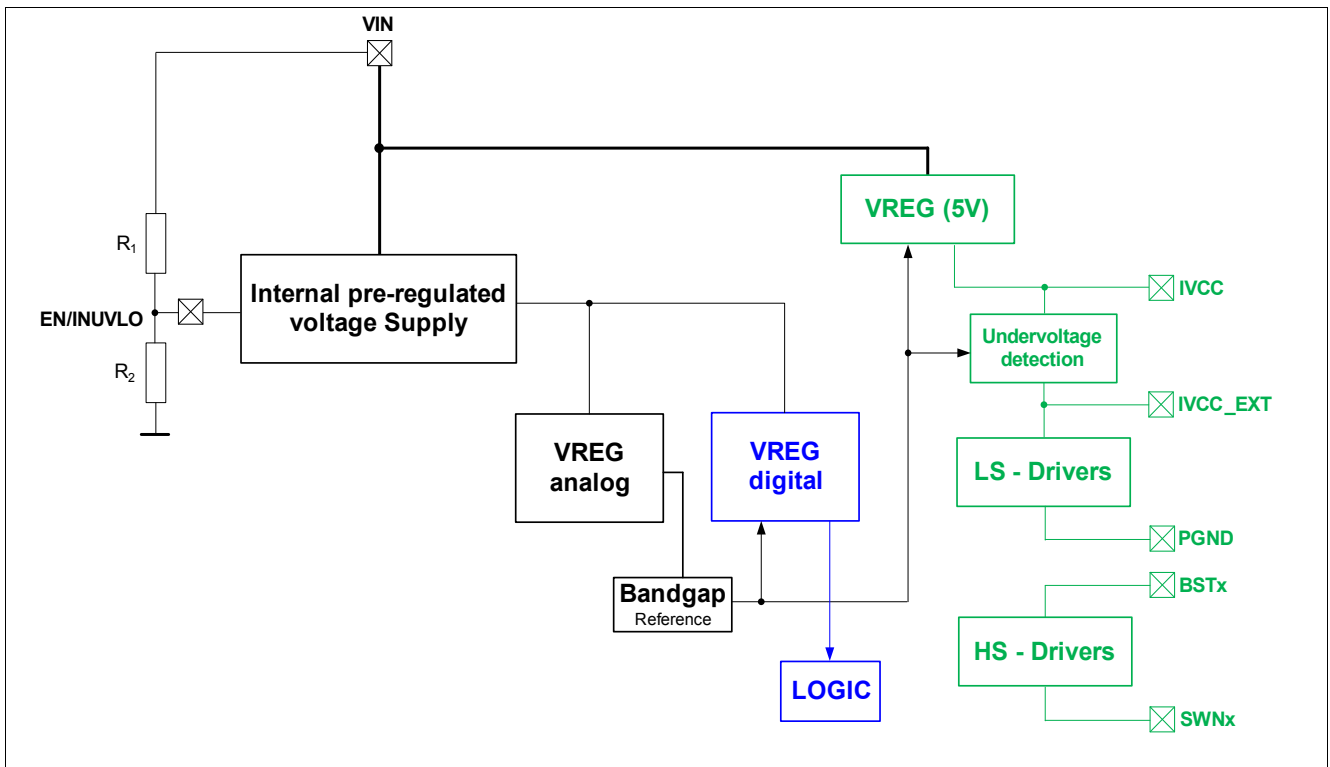

Figure 3 Power Supply Concept Drawing

Usage of EN/INUVLO pin in different applications

The pin EN/INUVLO is a double function pin and can be used to put the device into a low current consumption mode. An undervoltage threshold should be fixed by placing an external resistor divider (A) in order to avoid low voltage operating conditions. This pin can be driven by a μ C-port as shown in (B).

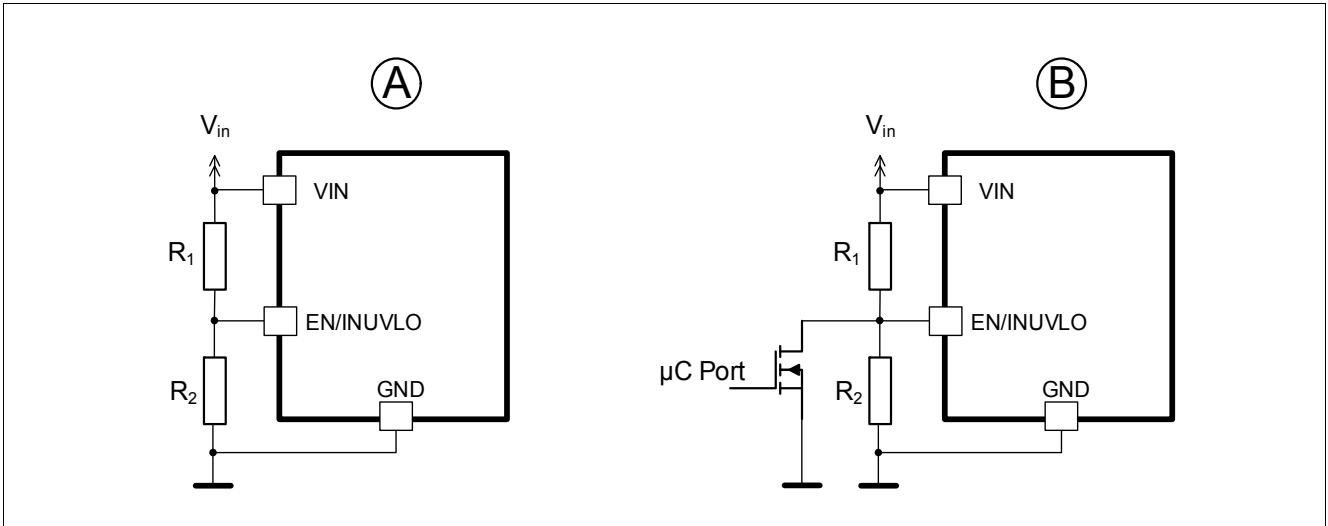

Figure 4 Usage of EN/INUVLO pin in different applications

5.1 Different Power States

TLD5190QV has the following power states:

- SLEEP state
- IDLE state
- ACTIVE state

The transition between the power states is determined according to these variables after a filter time of max. 3 clock cycles:

- VIN level
- EN/INUVLO level
- IVCC level
- IVCC_EXT level

The state diagram including the possible transitions is shown in [Figure 5](#).

The Power-up condition is entered when the supply voltage V_{VIN} exceeds its minimum supply voltage threshold $V_{VIN(ON)}$.

SLEEP

When the TLD5190QV is in the SLEEP state, all outputs are OFF, independently from the supply voltages V_{IN} , IVCC and IVCC_EXT. The current consumption is low. Refer to parameter: $I_{VIN(SLEEP)}$.

The transition from SLEEP to ACTIVE state requires a specified time: t_{ACTIVE} .

IDLE

In IDLE state the internal voltage regulator is working. Diagnosis functions are not available. The output drivers are switched OFF, independently from the supply voltages V_{IN} , IVCC and IVCC_EXT.

ACTIVE

In active state the device will start switching activity to provide power at the output only when PWMI = HIGH. To start the Highside gate drivers HSGDx the voltage level $V_{BSTx} - V_{SWNx}$ needs to be above the threshold $V_{BSTx} - V_{SWNx_UVth}$. In ACTIVE state the device current consumption via V_{IN} is dependent on the external MOSFET used and the switching frequency f_{SW} .

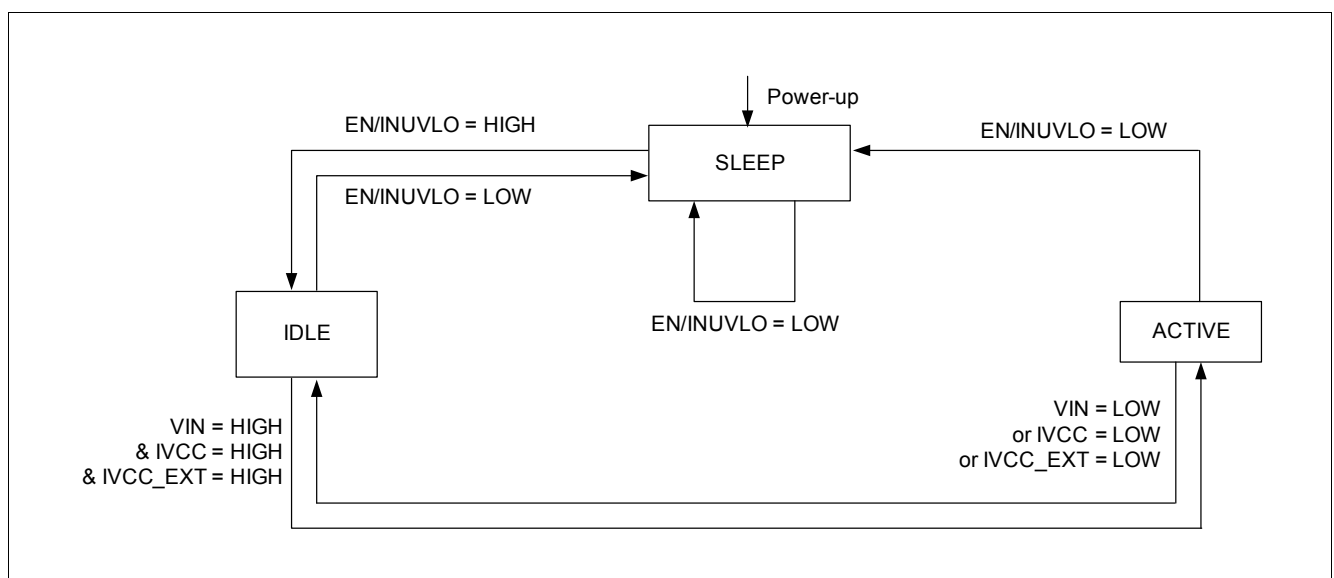

Figure 5 Simplified State Diagram

5.2 Electrical Characteristics

Table 5 EC Power Supply
 $V_{IN} = 8V$ to $36V$, $T_j = -40^{\circ}C$ to $+150^{\circ}C$, all voltages with respect to AGND; (unless otherwise specified)

Parameter	Symbol	Values			Unit	Note / Test Condition	Number
		Min.	Typ.	Max.			
Power Supply V_{IN}							
Input Voltage Startup	$V_{VIN(ON)}$	–	–	4.7	V	V_{IN} increasing; $V_{EN/INUVLO} = HIGH$; $IVCC = IVCC_EXT = 10\text{ mA}$;	P_5.3.1
Input Undervoltage switch OFF	$V_{VIN(OFF)}$	–	–	4.5	V	V_{IN} decreasing; $V_{EN/INUVLO} = HIGH$; $IVCC = IVCC_EXT = 10\text{ mA}$;	P_5.3.14
Device operating current	$I_{VIN(ACTIVE)}$	–	4.4	6	mA	¹⁾ ACTIVE mode; CLKOUT freq. 300KHz; $V_{PWMI} = 0\text{ V}$;	P_5.3.2
V_{IN} Sleep mode supply current	$I_{VIN(SLEEP)}$	–	–	1.5	μA	$V_{EN/INUVLO} = 0\text{ V}$; $V_{IN} = 13.5\text{ V}$; $V_{IVCC} = V_{IVCC_EXT} = 0\text{ V}$;	P_5.3.3
EN/INUVLO Pin characteristics							
Input Undervoltage falling Threshold	$V_{EN/INUVLO(th)}$	1.6	1.75	1.9	V	–	P_5.3.7
EN/INUVLO Rising Hysteresis	$V_{EN/INUVLO(hyst)}$	–	90	–	mV	¹⁾	P_5.3.8
EN/INUVLO input Current LOW	$I_{EN/INUVLO(LOW)}$	0.45	0.89	1.34	μA	$V_{EN/INUVLO} = 0.8\text{ V}$;	P_5.3.9
EN/INUVLO input Current HIGH	$I_{EN/INUVLO(HIGH)}$	1.1	2.2	3.3	μA	$V_{EN/INUVLO} = 2\text{ V}$;	P_5.3.10
Timings							
SLEEP mode to ACTIVE time	t_{ACTIVE}	–	–	0.7	ms	¹⁾ $V_{IVCC} = V_{IVCC_EXT}$; $C_{IVCC} = 10\mu F$; $V_{IN} = 13.5\text{ V}$;	P_5.3.11

¹⁾ Not subject to production test, specified by design.

6 Regulator Description

The TLD5190QV includes all of the functions necessary to provide constant current to the output as usually required to drive LEDs. A voltage mode regulation can also be implemented (Refer to [Chapter 6.6](#)).

It is designed to control 4 gate driver outputs in a H-Bridge topology by using only one inductor and 4 external MOSFETs. This topology is able to operate in high power BOOST, BUCK-BOOST and BUCK mode applications with maximum efficiency.

The transition between the different regulation modes is done automatically by the device itself, with respect to the application boundary conditions.

The transition phase between modes is seamless.

6.1 Regulator Diagram Description

The TLD5190QV includes two analog current control inputs (IIN1, IIN2) to limit the maximum Input current (Block A1 and A7 in [Figure 6](#)).

A second analog current control loop (A5, A6) connected to the sensing pins FBL, FBH regulates the output current.

The regulator function is implemented by a pulse width modulated (PWM) current mode controller. The error in the output current loop is used to determine the appropriate duty cycle to get a constant output current.

An external compensation network (R_{COMP} , C_{COMP}) is used to adjust the control loop to various application boundary conditions.

The inductor current for the current mode loop is sensed by the R_{SWCS} resistor.

R_{SWCS} is used also to limit the maximum external switches / inductor current.

If the Voltage across R_{SWCS} exceeds its overcurrent threshold (V_{SWCS_buck} or V_{SWCS_boost} for buck or boost operation respectively) the device reduces the duty cycle in order to bring the switches current below the imposed limit.

The current mode controller has a built-in slope compensation as well to prevent sub-harmonic oscillations.

The control loop logic block (LOGIC) provides a PWM signal to four internal gate drivers. The gate drivers (HSGD1,2 and LSGD1,2) are used to drive external MOSFETs in an H-Bridge setup .

The control loop block diagram displayed in [Figure 6](#) shows a typical constant current application. The voltage across R_{FB} sets the output current. R_{IN} is used to fix the maximum input current.

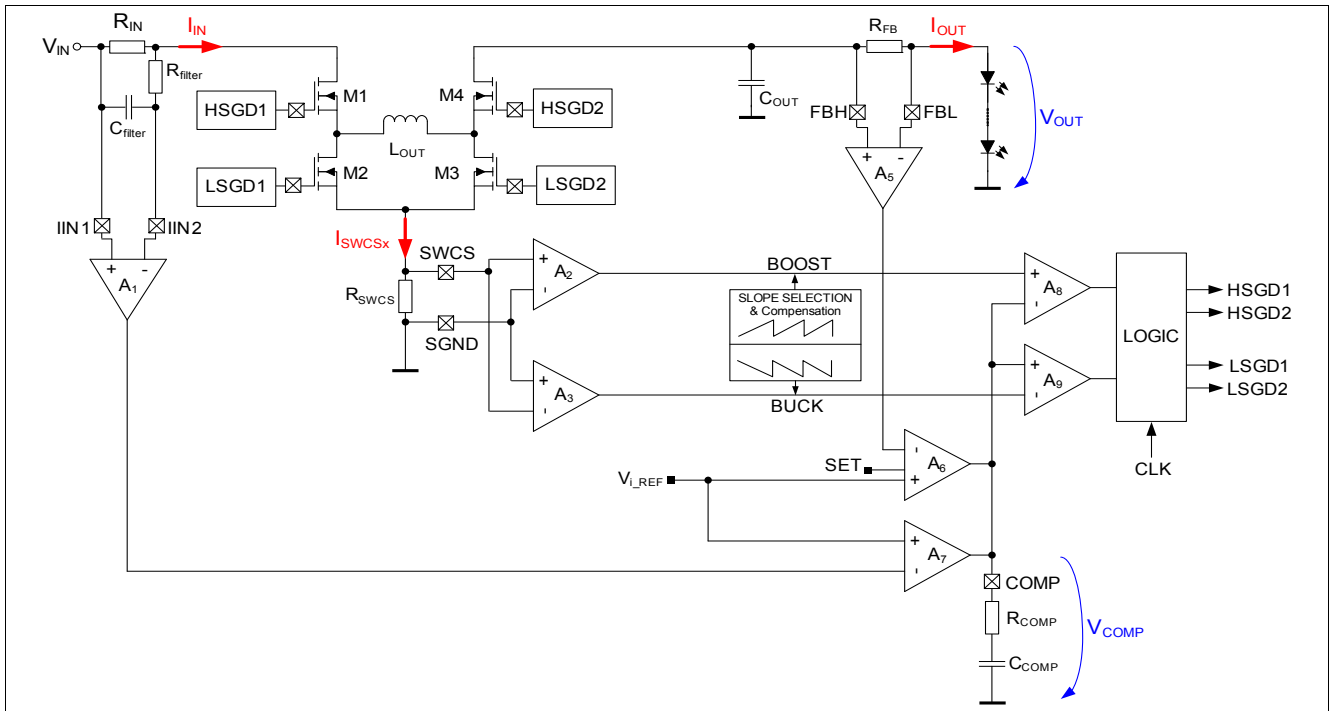

Figure 6 Regulator Block Diagram - TLD5190QV

6.2 Adjustable Soft Start Ramp

The soft start behavior limits the current through the inductor and the external MOSFET switches during initialization (at first turn on and restarting after output fault condition).

The soft start function gradually increases the current of the inductor (I_{OUT}) over t_{SOFT_START} to minimize potential overvoltage at the output. The soft start ramp is defined by a capacitor placed at the SOFT_START pin.

Selection of the SOFT_START capacitor (C_{SOFT_START}) can be done according to the approximate formula described in [Equation \(1\)](#):

$$t_{SOFT_START} = \frac{V_{ss_th_eff}}{I_{SOFT_START(PU)}} \cdot C_{SOFT_START} \quad (1)$$

Note: $V_{ss_th_eff}$ is the soft start effectiveness threshold, that depends on load condition. Its value is about 0.7V for the buck mode and 1.4V for the boost mode

The SOFT START pin is also used to define a fault filter time. Once an open load or a short on the output is detected, a pull-down current source $I_{SOFT_START_PD}$ (P_6.4.20) is activated. Through a pull-up resistor connected from VREF to the SOFT START pin it is possible to source a current higher than $I_{SOFT_START_PD}$, the TLD5190QV will latch OFF until the EN/INUVLO pin is toggled. Without any resistor to VREF the pull-down current decreases until $V_{SOFT_START_RESET}$ (P_6.4.22) is reached (the pull-up current source turns on again). If the fault condition hasn't been removed until $V_{SOFT_START_LOFF}$ (P_6.4.21) is reached, the pull-down current source $I_{SOFT_START_PD}$ turns on again initiating a new cycle. This will continue until the fault is removed.

6.3 Switching Frequency setup

The switching frequency can be set from 200 kHz to 700 kHz by an external resistor connected from the FREQ pin to GND or by supplying a sync signal as specified in chapter [Chapter 11.2](#). Select the switching frequency with an external resistor according to the graph in [Figure 7](#) or the following approximate formulas.

$$f_{SW} [kHz] = 5375 * R_{FREQ} [k\Omega]^{-0.8} \quad (2)$$

$$R_{FREQ} [k\Omega] = 46023 * f_{SW} [kHz]^{-1.25} \quad (3)$$

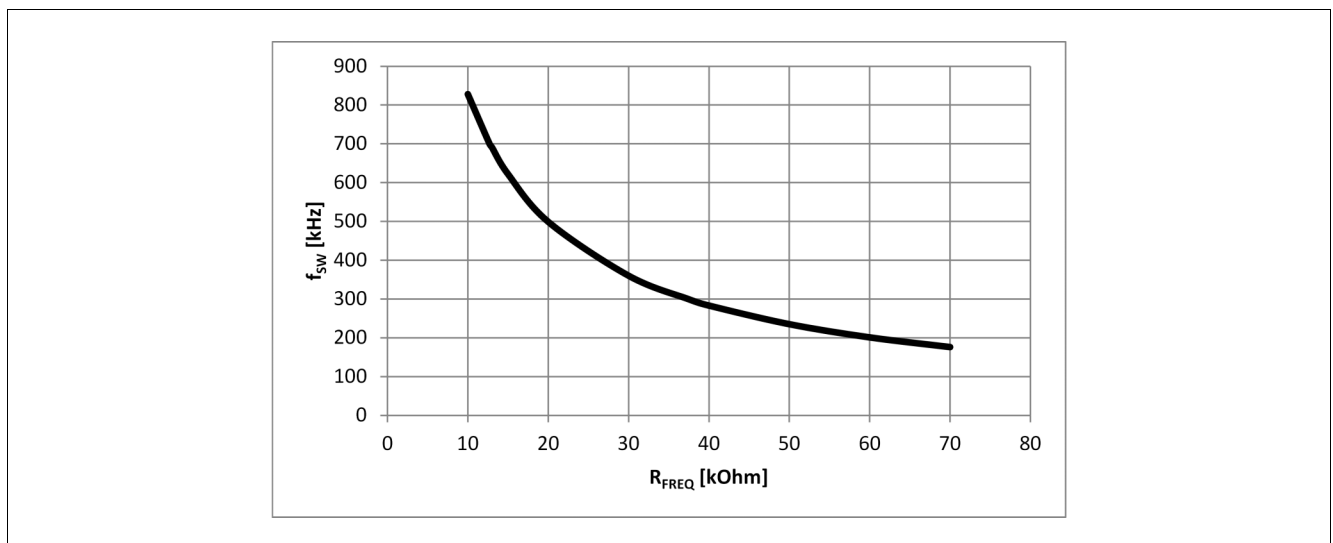

Figure 7 Switching Frequency f_{SW} versus Frequency Select Resistor to GND R_{FREQ}

6.4 Operation of 4 switches H-Bridge architecture

Inductor L_{OUT} connects in an H-Bridge configuration with 4 external N channel MOSFETs (M1, M2, M3 & M4)

- Transistor M1 and M3 provides a path between V_{IN} and ground through L_{OUT} in one direction (Driven by top and bottom gate drivers HSGD1 and LSGD2).
- Transistor M2 and M4 provides a path between V_{OUT} and ground through L_{OUT} in the other direction (Driven by top and bottom gate drivers HSGD2 and LSGD1).
- Nodes SWN1, SWN2, voltage across R_{SWCS} , input and load currents are also monitored by the TLD5190QV.

	BOOST MODE	BUCK-BOOST MODE	BUCK MODE
M1	ON	PWM	PWM
M2	OFF	PWM	PWM
M3	PWM	PWM	OFF
M4	PWM	PWM	ON

Figure 8 4 switches H-Bridge architecture Transistor Status summary

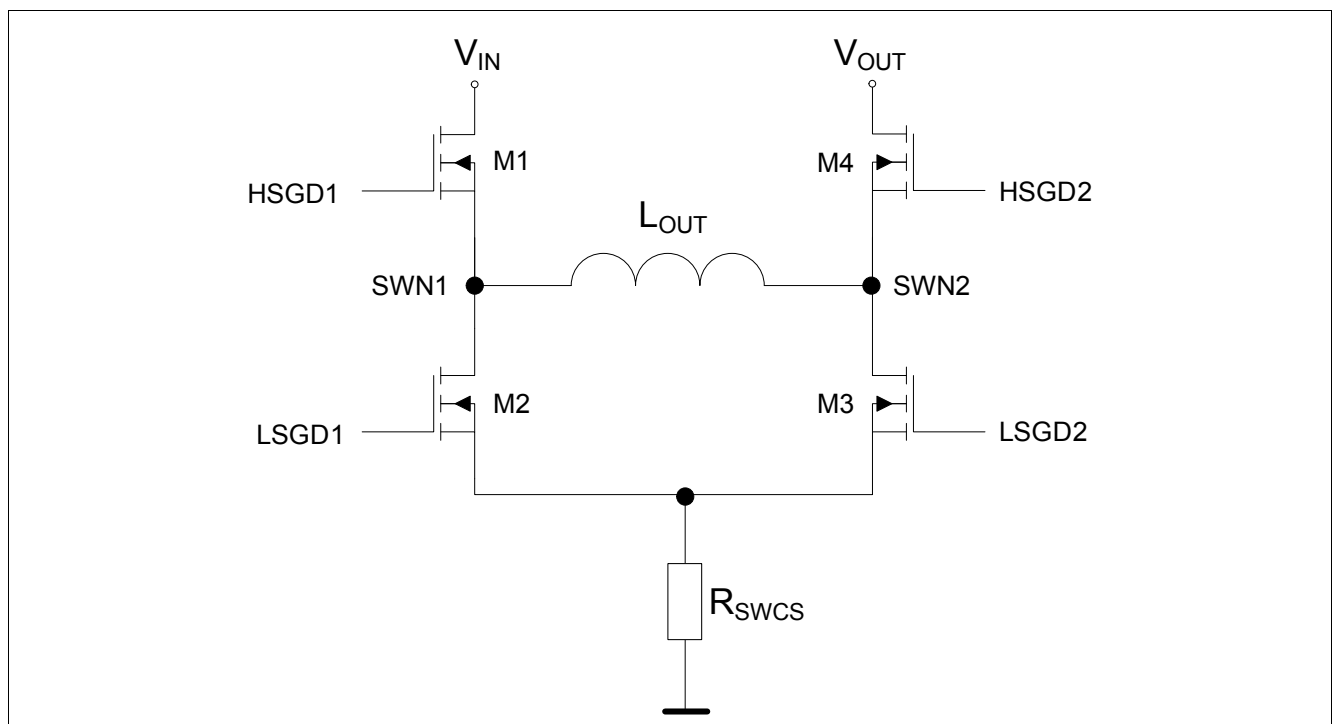

Figure 9 4 switches H-Bridge architecture overview

6.4.1 Boost mode ($V_{IN} < V_{OUT}$)

- M1 is always ON, M2 is always OFF
- Every cycle M3 turns ON first and inductor current is sensed (peak current control)
- M3 stays ON until the upper reference threshold is reached across R_{SWCS} (Energizing)

- M3 turns OFF, M4 turns ON until the end of the cycle (Recirculation)
- Switches M3 and M4 alternate, behaving like a typical synchronous boost Regulator (see [Figure 10](#))

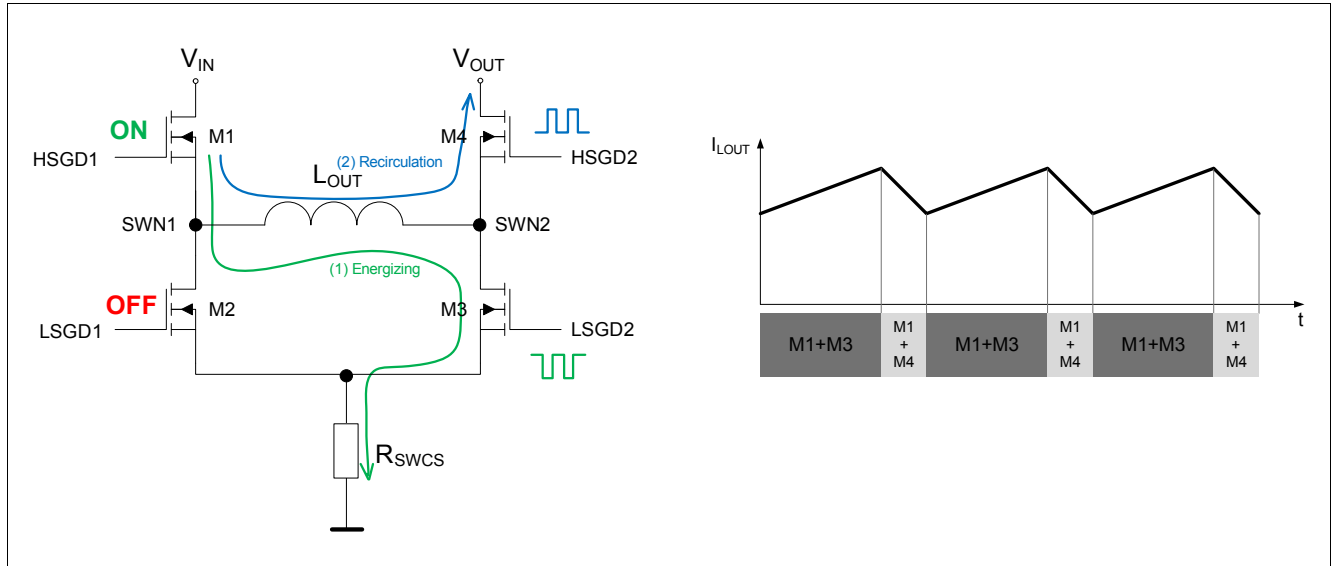

Figure 10 4 switches H-Bridge architecture in BOOST mode

Simplified comparison of 4 switches H-Bridge architecture to traditional asynchronous Boost approach.

- M2 is always OFF in this mode (open).
- M1 is always ON in this mode (closed connection of inductor to V_{IN}).
- M4 acts as a synchronous diode, with significantly lower conduction power losses ($I^2 \times R_{DSON}$ vs. $0.7V \times I$)

Note: Diode is source of losses and lower system efficiency!

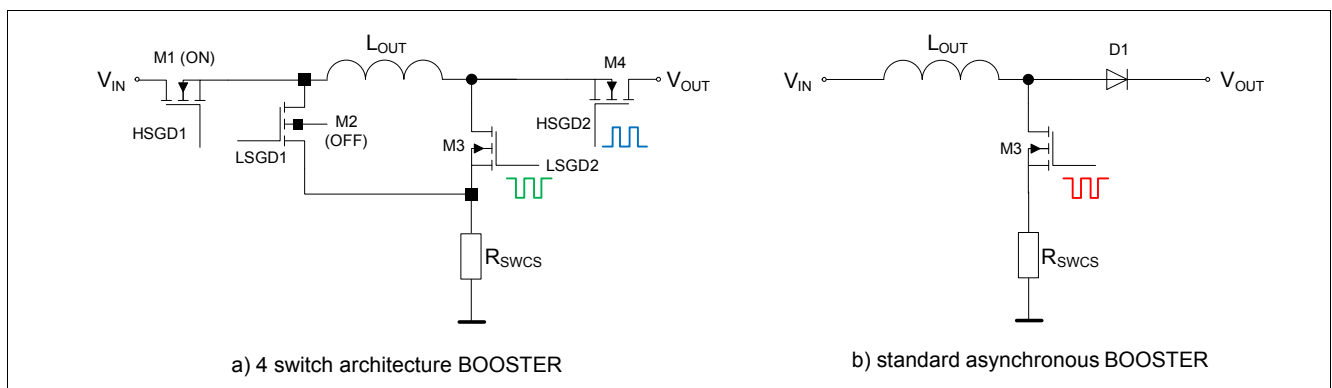

Figure 11 4 switches H-Bridge architecture in BOOST mode compared to standard async Booster

6.4.2 Buck mode ($V_{IN} > V_{OUT}$)

- M4 is always ON, M3 is always OFF
- Every cycle M2 turns ON and inductor current is sensed (valley current control)
- M2 stays ON until the lower reference threshold is reached across R_{swcs} (Recirculation)

- M2 turns OFF, M1 turns ON until the end of the cycle (Energizing)
- Switches M1 and M2 alternate, behaving like a typical synchronous BUCK Regulator (see [Figure 12](#))

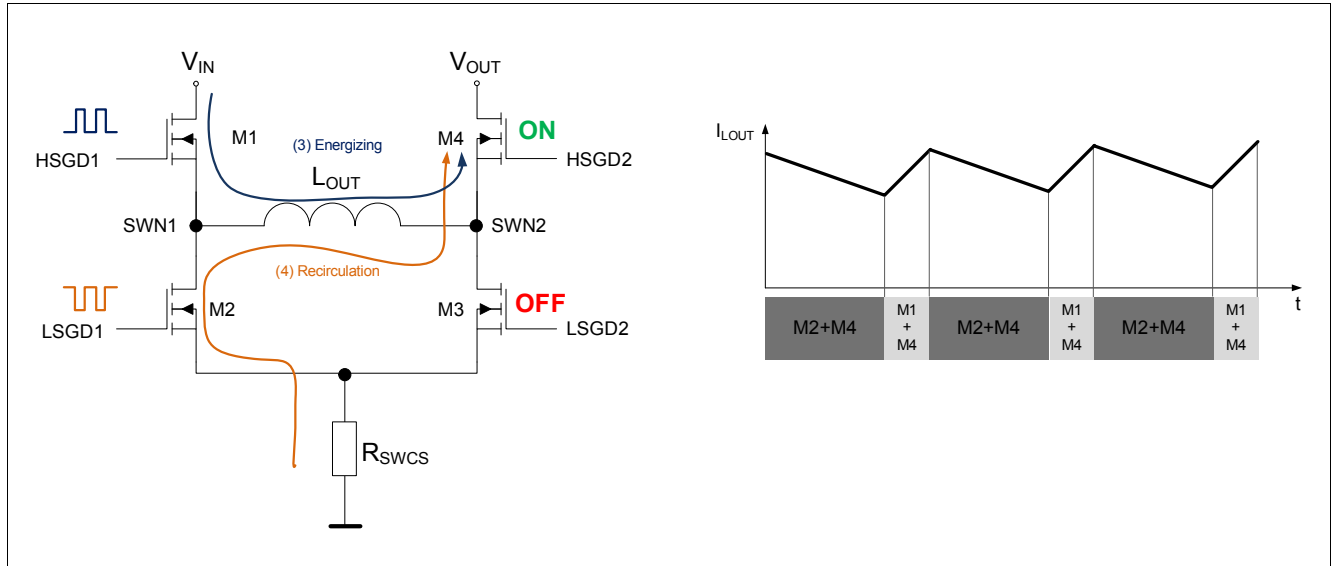

Figure 12 4 switches H-Bridge architecture in BUCK mode

Simplified comparison of 4 switches architecture to traditional asynchronous Buck approach.

- M3 is always OFF in this mode (open).
- M4 is always ON in this mode (closed connection inductor to V_{OUT}).
- M2 acts as a synchronous diode, with significantly lower conduction losses ($I^2 \times R_{DSON}$ vs. $0.7V \times I$)

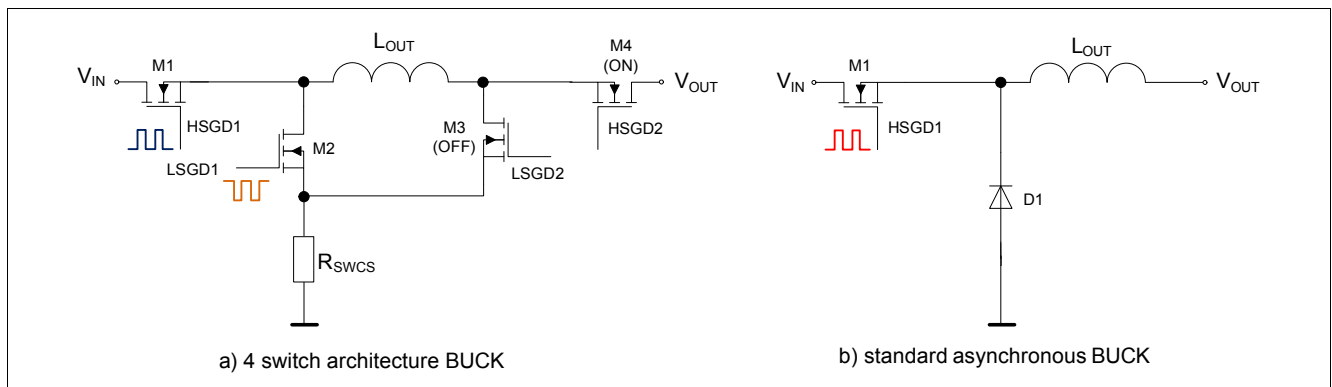

Figure 13 4 switches H-Bridge architecture in BUCK mode compared to standard async BUCK

6.4.3 Buck-Boost mode ($V_{IN} \sim V_{OUT}$)

- When V_{IN} is close to V_{OUT} the controller is in Buck-Boost operation.
- All switches are switching in buck-boost operation. The direct energy transfer from the Input to the output ($M1+M4 = ON$) is beneficial to reduce ripple current and improves the energy efficiency of the Buck-Boost control scheme.
- The two buck boost waveforms and switching behaviors are displayed in [Figure 14](#) below.

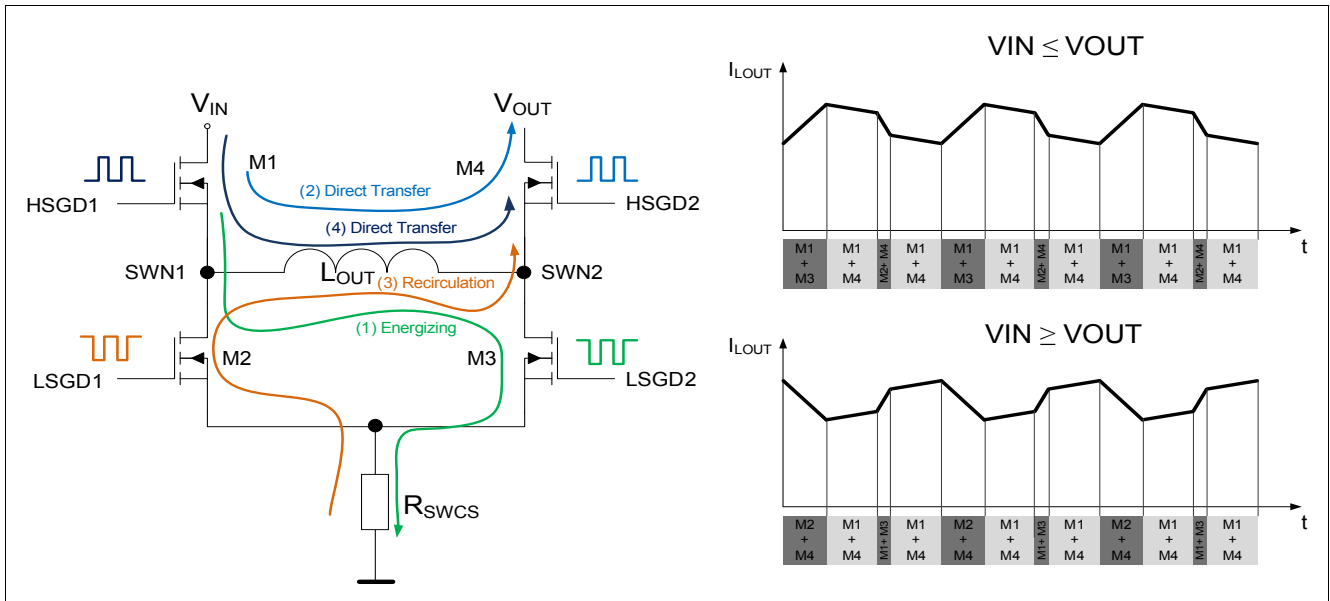

Figure 14 4 switches H-Bridge architecture in BUCK-BOOST mode

6.5 Flexible current sense

The flexible current sense implementation enables highside and lowside current sensing.

The **Figure 15** displays the application examples for the highside and lowside current sense concept.

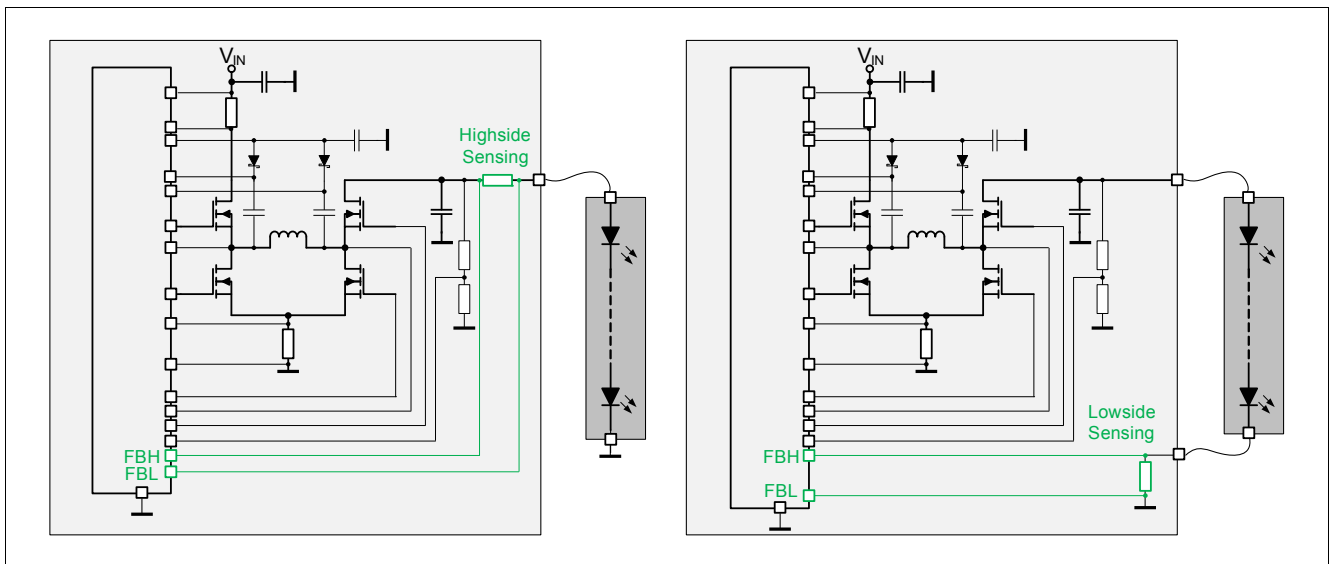

Figure 15 Highside and lowside current sensing - TLD5190QV

6.6 Programming Output Voltage (Constant Voltage Regulation)

For a voltage regulator, the output voltage can be set by selecting the values R_{FB1} , R_{FB2} and R_{FB3} according to the following [Equation \(4\)](#):

$$V_{OUT} = \left(I_{FBH} + \frac{V_{FBH-FBL}}{R_{FB2}} \right) \cdot R_{FB1} + \left(\frac{V_{FBH-FBL}}{R_{FB2}} - I_{FBL} \right) \cdot R_{FB3} + V_{FBH-FBL} \quad (4)$$

If Analog dimming is performed, due to the variations on the I_{FBL} (I_{FBL_HSS} (P_6.4.9) and I_{FBL_LSS} (P_6.4.40)) current on the entire voltage spanning, a non linearity on the output voltage may be observed. To minimize this effect RFBx resistors should be properly dimensioned.

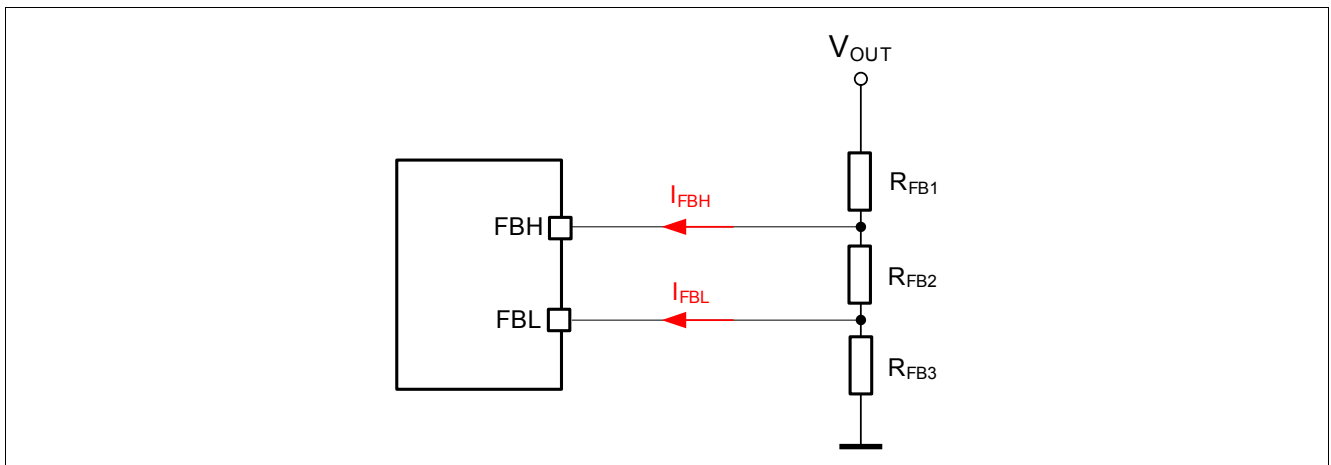

Figure 16 Programming Output Voltage (Constant Voltage Regulation)

6.7 Electrical Characteristics

Table 6 EC Regulator
 $V_{IN} = 8V$ to $36V$, $T_j = -40^{\circ}C$ to $+150^{\circ}C$, all voltages with respect to AGND; (unless otherwise specified)

Parameter	Symbol	Values			Unit	Note / Test Condition	Number
		Min.	Typ.	Max.			
Regulator:							
$V_{(FBH-FBL)}$ threshold	$V_{(FBH-FBL)}$	145.5	150	154.5	mV	$T_j = 25^{\circ}C$; $V_{SET} = 2V$;	P_6.4.1
$V_{(FBH-FBL)}$ threshold	$V_{(FBH-FBL)}$	144	150	156	mV	$V_{SET} = 2V$;	P_6.4.2
$V_{(FBH-FBL)}$ threshold @ analog dimming 10%	$V_{(FBH-FBL)}_{10}$	10	15	20	mV	$V_{SET} = 0.32V$;	P_6.4.6
FBH Bias current @ highside sensing setup	I_{FBH_HSS}	65	110	155	μA	¹⁾ $V_{FBL} = 7V$; $V_{FBH-FBL} = 150mV$;	P_6.4.8
FBL Bias current @ highside sensing setup	I_{FBL_HSS}	17	30	43	μA	¹⁾ $V_{FBL} = 7V$; $V_{FBH-FBL} = 150mV$;	P_6.4.9
FBH Bias current @ lowside sensing setup	I_{FBH_LSS}	-7.5	-4	-2.5	μA	¹⁾ $V_{FBL} = 0V$; $V_{FBH-FBL} = 150mV$;	P_6.4.39
FBL Bias current @ lowside sensing setup	I_{FBL_LSS}	-45	-30	-20	μA	¹⁾ $V_{FBL} = 0V$; $V_{FBH-FBL} = 150mV$;	P_6.4.40
FBH-FBL High Side sensing entry threshold	$V_{FBH_HSS_jnc}$	-	2	-	V	¹⁾ V_{FBH1} increasing;	P_6.9.1
FBH-FBL High Side sensing exit threshold	$V_{FBH_HSS_dec}$	-	1.75	-	V	¹⁾ V_{FBH} decreasing;	P_6.9.2
OUT Current sense Amplifier g_m	$IFBx_{gm}$	-	890	-	μS	¹⁾	P_6.4.10
Output Monitor Voltage	$V_{IOUTMON}$	1.33	1.4	1.47	V	$V_{FBH-FBL} = 150mV$;	P_6.4.11
Maximum BOOST Duty Cycle	D_{BOOST_MAX}	89	91	93	%	$f_{sw} = 300kHz$;	P_6.4.12
Input Current Sense threshold $V_{IIN1-IIN2}$	$V_{IIN1-IIN2}$	46	50	54	mV	-	P_6.4.13
Input Current sense Amplifier g_m	I_{IN_gm}	-	2.12	-	mS	¹⁾	P_6.4.14
Input current Monitor Voltage	V_{IINMON}	0.95	1	1.05	V	¹⁾ $V_{IIN1-IIN2} = 50mV$; $V_{IIN1} = V_{VIN(ON)}$ to $55V$;	P_6.4.15
Switch Peak Over Current Threshold - BOOST	V_{SWCS_boost}	40	50	60	mV	¹⁾	P_10.8.15
Switch Peak Over Current Threshold - BUCK	V_{SWCS_buck}	-60	-50	-40	mV	¹⁾	P_10.8.16
Soft Start							
Soft Start pull up current	$I_{Soft_Start_PU}$	22	26	32	μA	$V_{Soft_Start} = 1V$;	P_6.4.19
Soft Start pull down current	$I_{Soft_Start_PD}$	2.2	2.6	3.2	μA	$V_{Soft_Start} = 1V$;	P_6.4.20
Soft Start Latch-OFF Threshold	$V_{Soft_Start_LOFF}$	1.65	1.75	1.85	V	-	P_6.4.21

Table 6 EC Regulator (cont'd)
 $V_{IN} = 8V$ to $36V$, $T_j = -40^\circ C$ to $+150^\circ C$, all voltages with respect to AGND; (unless otherwise specified)

Parameter	Symbol	Values			Unit	Note / Test Condition	Number
		Min.	Typ.	Max.			
Soft Start Reset Threshold	$V_{Soft_Start_RESET}$	0.1	0.2	0.3	V	–	P_6.4.22
Soft Start Voltage during regulation	$V_{Soft_Start_reg}$	1.9	2	2.1	V	¹⁾ No Faults	P_6.9.3

Oscillator

Switching Frequency	f_{SW}	285	300	315	kHz	$T_j = 25^\circ C$; $R_{FREQ} = 37.4\ k\Omega$;	P_6.4.23
SYNC Frequency	f_{SYNC}	200	–	700	kHz	–	P_6.4.24
SYNC Turn On Threshold	$V_{SYNC,ON}$	2	–	–	V	–	P_6.4.25
SYNC Turn Off Threshold	$V_{SYNC,OFF}$	–	–	0.8	V	–	P_6.4.26
SYNC High Input Current	$I_{SYNC,H}$	15	30	45	μA	$V_{SYNC} = 2.0\ V$;	P_6.4.62
SYNC Low Input Current	$I_{SYNC,L}$	6	12	18	μA	$V_{SYNC} = 0.8\ V$;	P_6.4.63

Gate Driver for external Switch

Gate Driver undervoltage threshold $V_{BSTx} - V_{SWNx_UVth}$	V_{BSTx} V_{SWNx_UVth}	3.4	–	4	V	$V_{BSTx} - V_{SWNx}$ decreasing;	P_6.4.64
HSGDx NMOS driver on-state resistance (Gate Pull Up)	$R_{DS(ON_PU)}$ HS	1.4	2.3	3.7	Ω	$V_{BSTx} - V_{SWNx} = 5\ V$; $I_{source} = 100\ mA$;	P_6.4.28
HSGDx NMOS driver on-state resistance (Gate Pull Down)	$R_{DS(ON_PD)}$ HS	0.6	1.2	2.2	Ω	$V_{BSTx} - V_{SWNx} = 5\ V$; $I_{sink} = 100\ mA$;	P_6.4.29
LSGDx NMOS driver on-state resistance (Gate Pull Up)	$R_{DS(ON_PU)}$ LS	1.4	2.3	3.7	Ω	$V_{IVCC_EXT} = 5\ V$; $I_{source} = 100\ mA$;	P_6.4.30
LSGDx NMOS driver on-state resistance (Gate Pull Down)	$R_{DS(ON_PD)}$ LS	0.4	1.2	1.8	Ω	$V_{IVCC_EXT} = 5\ V$; $I_{sink} = 100\ mA$;	P_6.4.31
HSGDx Gate Driver peak sourcing current	I_{HSGDx_SRC}	380	–	–	mA	¹⁾ $V_{HSGDx} - V_{SWNx} = 1\ V$ to $4\ V$; $V_{BSTx} - V_{SWNx} = 5\ V$	P_6.4.32
HSGDx Gate Driver peak sinking current	I_{HSGDx_SNK}	410	–	–	mA	¹⁾ $V_{HSGDx} - V_{SWNx} = 4\ V$ to $1\ V$; $V_{BSTx} - V_{SWNx} = 5\ V$	P_6.4.33
LSGDx Gate Driver peak sourcing current	I_{LSGDx_SRC}	370	–	–	mA	¹⁾ $V_{LSGDx} = 1\ V$ to $4\ V$; $V_{IVCC_EXT} = 5\ V$;	P_6.4.34
LSGDx Gate Driver peak sinking current	I_{LSGDx_SNK}	550	–	–	mA	¹⁾ $V_{LSGDx} = 4\ V$ to $1\ V$; $V_{IVCC_EXT} = 5\ V$;	P_6.4.35

Table 6 EC Regulator (cont'd)

$V_{IN} = 8V$ to $36V$, $T_j = -40^{\circ}C$ to $+150^{\circ}C$, all voltages with respect to AGND; (unless otherwise specified)

Parameter	Symbol	Values			Unit	Note / Test Condition	Number
		Min.	Typ.	Max.			
LSGDx OFF to HSGD ON delay	t_{LSOFF-} HSON_delay	15	30	40	ns	¹⁾	P_6.4.36
HSGDx OFF to LSGD ON delay	t_{HSOFF-} LSON_delay	35	60	75	ns	¹⁾	P_6.4.37

1) Not subject to production test, specified by design

7 Digital Dimming Function

To change brightness of LED loads without affecting the lighting-color of the LED a digital Dimming function via PWM (Pulse Width Modulation) is often required.

7.1 Description

PWM dimming is commonly practiced to prevent color shift in the LED light source.

Via Parallel Interface

The PWMI pin detects a pulse width modulated (PWM) signal that disable the gate drivers from delivering output current.

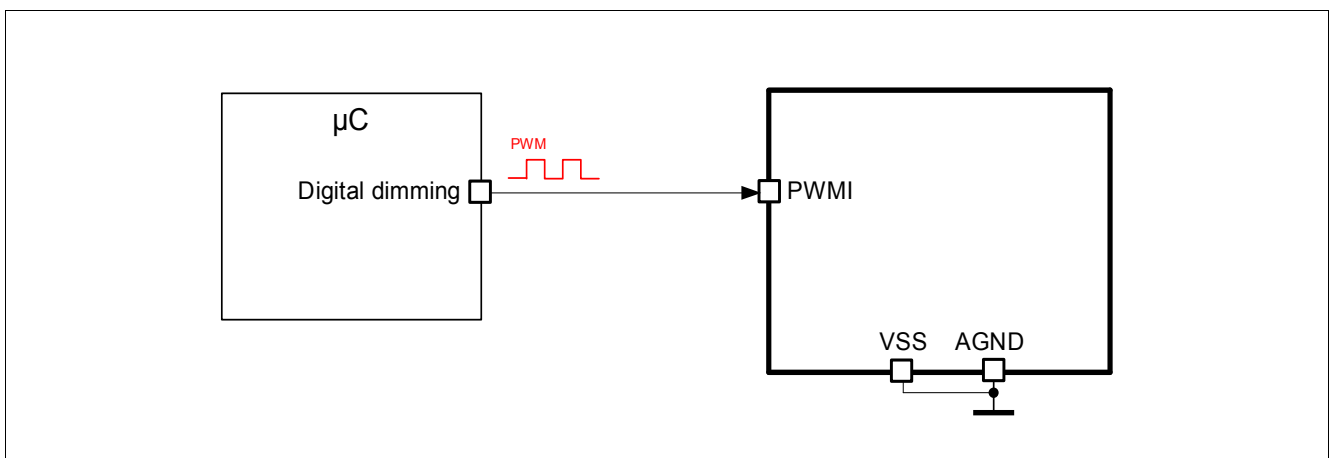

Figure 17 Digital Dimming Overview

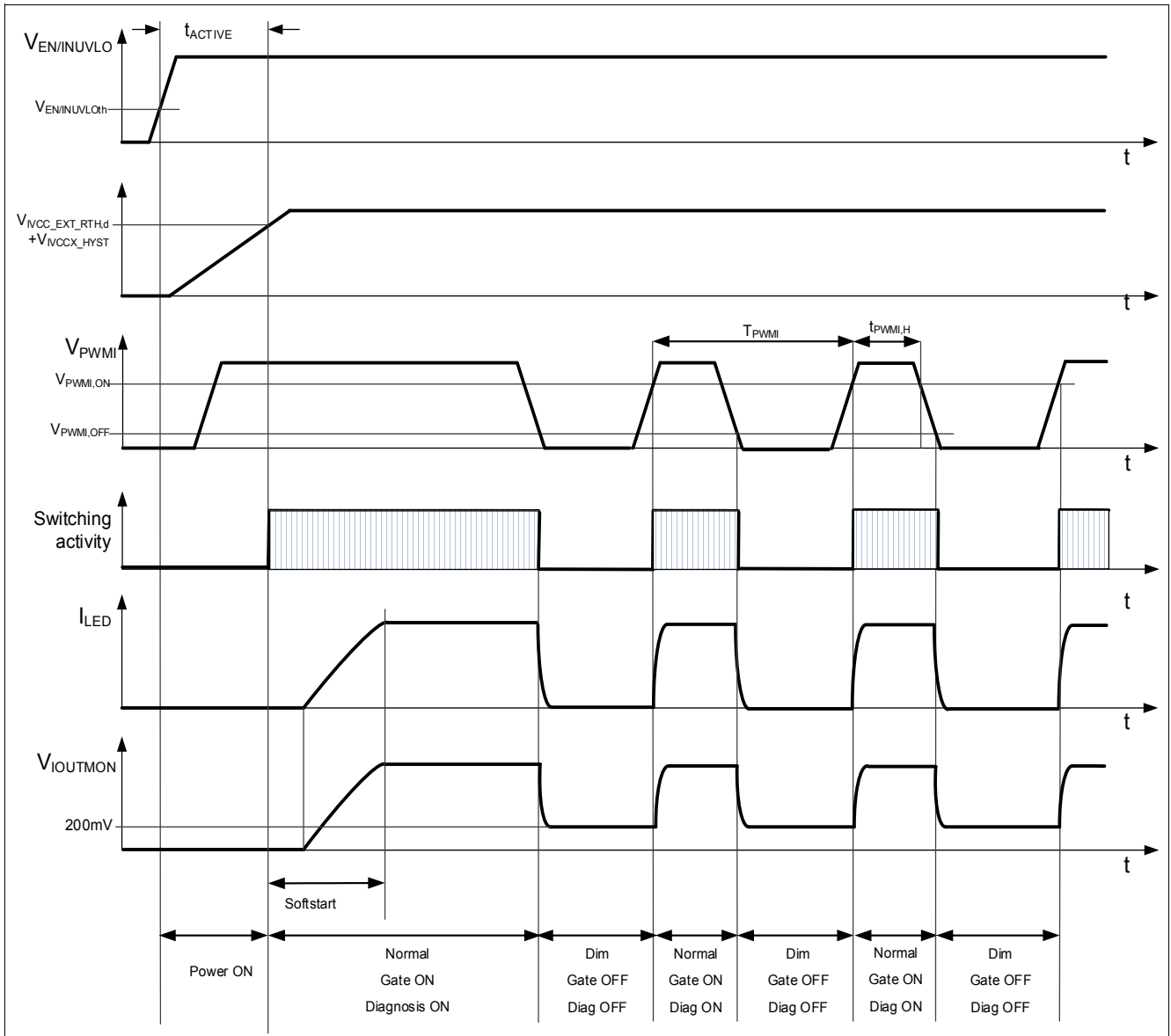

Figure 18 Timing Diagram LED Dimming and Start up behavior example (V_{VIN} stable in the functional range and not during startup)

7.2 Electrical Characteristics

Table 7 EC Digital Dimming

$V_{IN} = 8V$ to $36V$, $T_j = -40^{\circ}C$ to $+150^{\circ}C$, all voltages with respect to AGND; (unless otherwise specified)

Parameter	Symbol	Values			Unit	Note / Test Condition	Number
		Min.	Typ.	Max.			
PWMI Input:							
PWMI Turn On Threshold	$V_{PWMI,ON}$	2	–	–	V	–	P_7.2.1
PWMI Turn Off Threshold	$V_{PWMI,OFF}$	–	–	0.8	V	–	P_7.2.2
PWMI High Input Current	$I_{PWMI,H}$	15	30	45	μA	$V_{PWMI} = 2.0 V$;	P_7.2.4
PWMI Low Input Current	$I_{PWMI,L}$	6	12	18	μA	$V_{PWMI} = 0.8 V$;	P_7.2.5

8 Analog Dimming

The analog dimming feature allows further control of the output current. This approach is used to:

- Reduce the default current in a narrow range to adjust to different binning classes of the used LEDs.
- Adjust the load current to enable the usage of one hardware for several LED types where different current levels are required.
- Reduce the current at high temperatures (protect LEDs from overtemperature).
- Reduce the current at low input voltages (for example, cranking-pulse breakdown of the supply or power derating).

8.1 Description

The analog dimming feature is adjusting the average load current level via the control of the feedback error Amplifier voltage ($V_{FBH-FBL}$).

The SET pin is used to adjust the mean output current/voltage. The V_{SET} range where analog dimming is enabled is from 200mV to 1.5V. Different application scenarios are described in [Figure 20](#).

Using the SET pin to adjust the output current:

For the calculation of the output current I_{OUT} the following [Equation \(5\)](#) is used:

$$I_{OUT} = \frac{V_{FBH} - V_{FBL}}{R_{FB}} \quad (5)$$

A decrease of the average output current can be achieved by controlling the voltage at the SET pin (V_{SET}) between 0.2V and 1.4V. The mathematical relation is given in the [Equation \(6\)](#) below:

$$I_{OUT} = \frac{V_{SET} - 200 \text{ mV}}{R_{FB} \cdot 8} \quad (6)$$

If V_{SET} is 200mV (typ.) the LED current is only determined by the internal offset voltages of the comparators. To assure the switching activity is stopped and $I_{OUT}=0$, V_{SET} has to be <100mV, see [Figure 19](#)

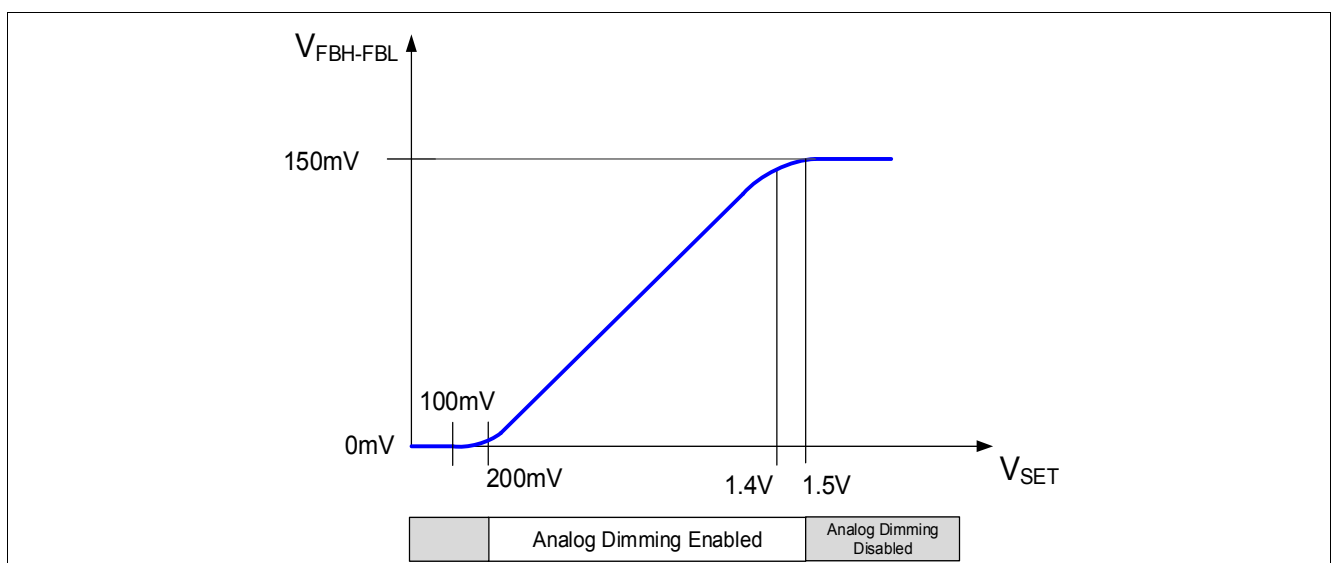

Figure 19 Analog Dimming Overview

Multi-purpose usage of the Analog dimming feature

- 1) A μC integrated digital analog converter (DAC) output or a stand alone DAC can be used to supply the SET pin of the TLD5190QV.
- 2) The usage of an external resistor divider connected between V_{REF} (accurate regulated supply output) SET and GND can be chosen for systems without μC on board. The concept allows control of the LED current by placing low power resistors.
- 3) Furthermore a temperature sensitive resistor (Thermistor) to protect the LED loads from thermal destruction can be connected.
- 4) If the analog dimming feature is not needed, the SET pin should be connected to the VREF pin.
- 5) Instead of a DAC, the μC can provide a PWM signal and an external R-C filter to produce a constant voltage for the analog dimming. The voltage level depends on the PWM frequency (f_{PWM}) and duty cycle which can be controlled by the μC software after reading the coding resistor placed on the LED module.

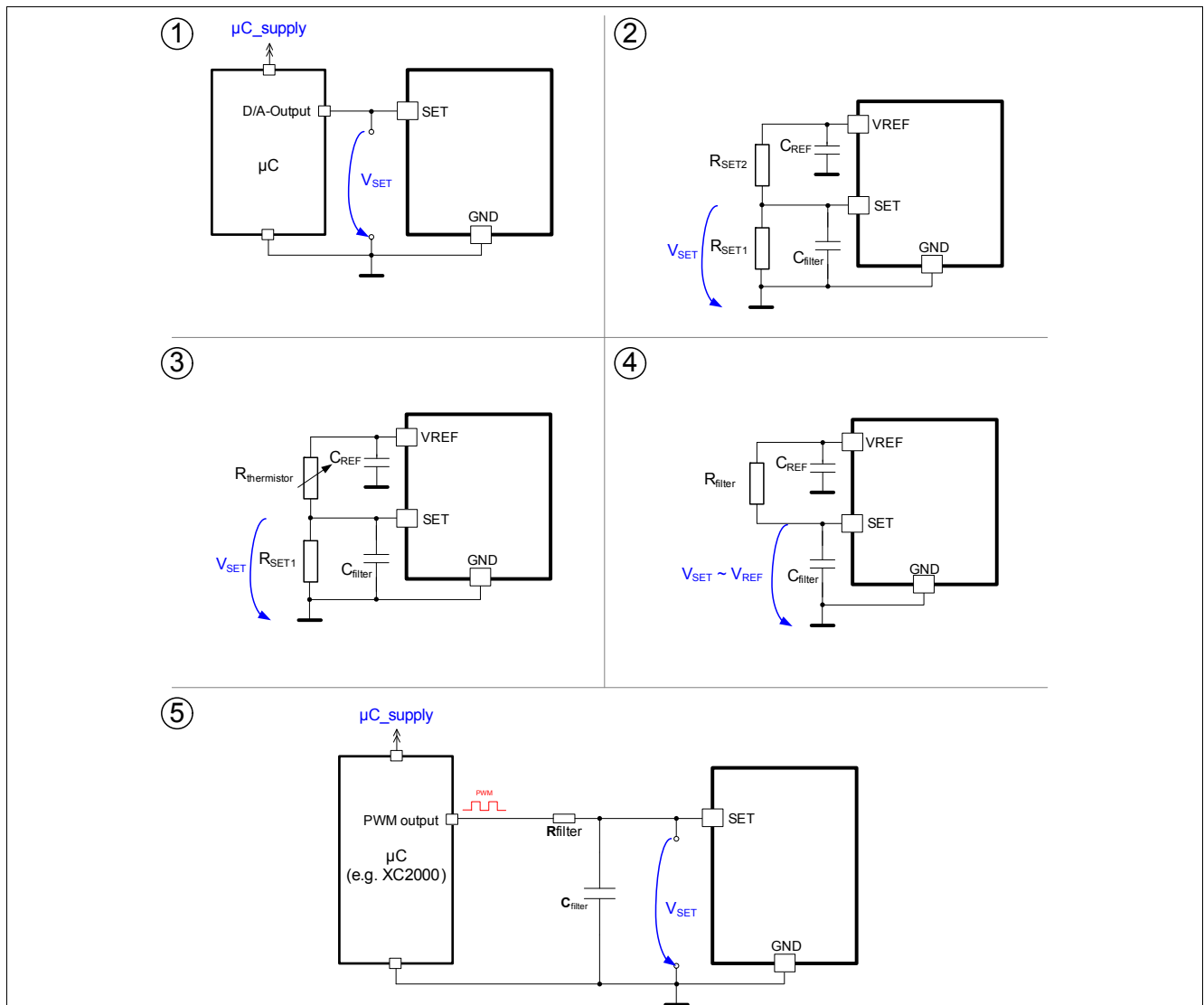

Figure 20 Different use cases for analog dimming pin SET

8.2 Electrical Characteristics

Table 8 EC Analog Dimming

$V_{IN} = 8V$ to $36V$, $T_j = -40^{\circ}C$ to $+150^{\circ}C$, all voltages with respect to AGND; (unless otherwise specified)

Parameter	Symbol	Values			Unit	Note / Test Condition	Number
		Min.	Typ.	Max.			
Source current on SET Pin	I_{SET_source}	–	–	1	μA	¹⁾ $V_{SET} = 0.2 V$ to $1.4V$;	P_8.3.4

1) Specified by design: not subject to production test.

9 Linear Regulator

The TLD5190QV features an integrated voltage regulator for the supply of the internal gate driver stages. Furthermore an external voltage regulator can be connected to the IVCC_EXT pin to achieve an alternative gate driver supply if required.

9.1 IVCC Description

When the IVCC pin is connected to the IVCC_EXT pin, the internal linear voltage regulator supplies the internal gate drivers with a typical voltage of 5V and current up to I_{LIM} (P_9.2.2). An external output capacitor with low ESR is required on pin IVCC for stability and buffering transient load currents. During normal operation the external MOSFET switches will draw transient currents from the linear regulator and its output capacitor (Figure 21, drawing A). Proper sizing of the output capacitor must be considered to supply sufficient peak current to the gate of the external MOSFET switches. A minimum capacitance value is given in parameter C_{IVCC} (P_9.2.4).

Alternative IVCC_EXT Supply Concept:

The IVCC_EXT pin can be used for an external voltage supply to alternatively supply the MOSFET Gate drivers. This concept is beneficial in the high input voltage range to avoid power losses in the IC (Figure 21, drawing B).

Integrated undervoltage protection for the external switching MOSFET:

An integrated undervoltage reset threshold circuit monitors the linear regulator output voltage. This undervoltage reset threshold circuit will turn OFF the gate drivers in case the IVCC or IVCC_EXT voltage falls below their undervoltage Reset switch OFF Thresholds $V_{IVCC_RTH,d}$ (P_9.2.9) and $V_{IVCC_EXT_RTH,d}$ (P_9.2.5).

The Undervoltage Reset threshold for the IVCC and the IVCC_EXT pins help to protect the external switches from excessive power dissipation by ensuring the gate drive voltage is sufficient to enhance the gate of the external logic level N-channel MOSFETs.

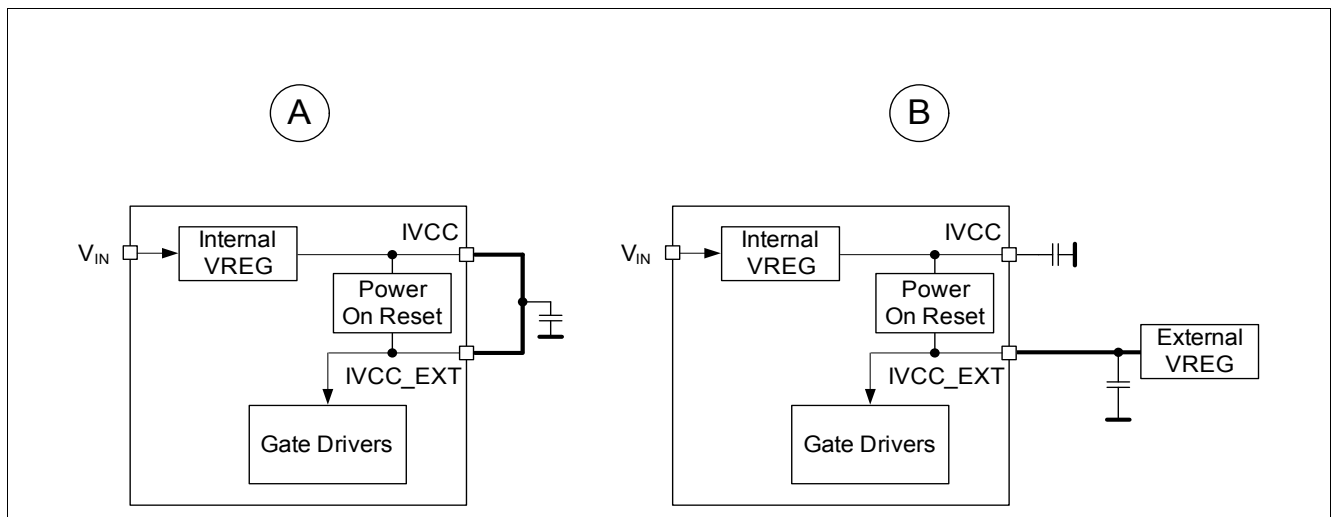

Figure 21 Voltage Regulator Configurations

9.2 Electrical Characteristics

Table 9 EC Line Regulator
 $V_{IN} = 8V$ to $36V$, $T_j = -40^{\circ}C$ to $+150^{\circ}C$, all voltages with respect to AGND; (unless otherwise specified)

Parameter	Symbol	Values			Unit	Note / Test Condition	Number
		Min.	Typ.	Max.			
IVCC							
Output Voltage	V_{IVCC}	4.8	5	5.2	V	$V_{IN} = 13.5 V$; $0.1 mA \leq I_{IVCC} \leq 50 mA$;	P_9.2.1
Output Current Limitation	I_{LIM}	70	90	110	mA	¹⁾ $V_{IVCC} = 4 V$;	P_9.2.2
Drop out Voltage ($V_{IN} - V_{IVCC}$)	V_{DR}	–	200	350	mV	$V_{IN} = 5 V$; $I_{IVCC} = 10 mA$;	P_9.2.3
IVCC Buffer Capacitor	C_{IVCC}	10	–	–	μF	^{1) 2)}	P_9.2.4
IVCC_EXT Undervoltage Reset switch OFF Threshold	$V_{IVCC_EXT_RTH,d}$	3.7	3.9	4.1	V	³⁾ V_{IVCC_EXT} decreasing;	P_9.2.5
IVCC Undervoltage Reset switch OFF Threshold	$V_{IVCC_RTH,d}$	3.7	3.9	4.1	V	³⁾ V_{IVCC} decreasing;	P_9.2.9
IVCC and IVCC_EXT Undervoltage Hysteresis	V_{IVCCX_HYST}	0.3	0.33	0.36	V	V_{IVCC} increasing; V_{IVCC_EXT} increasing	P_9.2.6
VREF voltage	V_{REF}	1.94	2	2.06	V	$0 \leq I_{VREF} \leq 200 \mu A$;	P_9.2.8

1) Not subject to production test, specified by design

2) Minimum value given is needed for regulator stability; application might need higher capacitance than the minimum. Use capacitors with LOW ESR.

3) Selection of external switching MOSFET is crucial. $V_{IVCC_EXT_RTH,d}$ and $V_{IVCC_RTH,d}$ min. as worst case V_{GS} must be considered.

10 Protection and Diagnostic Functions

10.1 Description

The TLD5190QV has integrated circuits to diagnose and protect against overvoltage, open load, short circuits of the load and overtemperature faults.

In IDLE state, only the Over temperature Shut Down, Over Temperature Warning, IVCC or IVCC_EXT Undervoltage Monitor or $V_{EN/INUVLO}$ Undervoltage Monitor are reported according to specifications.

In [Figure 22](#) a summary of the protection, diagnostic and monitor functions is displayed.

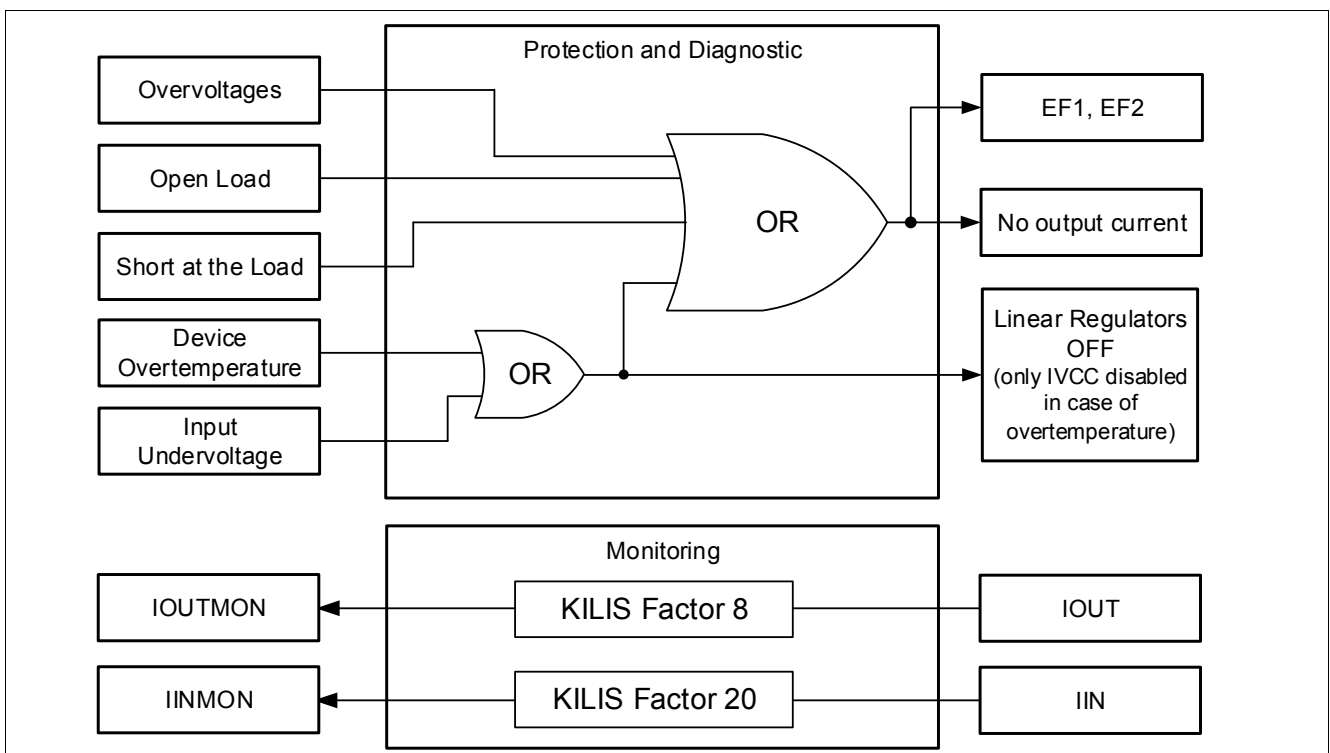

Figure 22 Protection, Diagnostic and Monitoring Overview - TLD5190QV

Input		Output			
Condition	Level*	EF1	EF2	Gate Drivers	IVCC
Open Load / Overvoltages	False	H	H	Sw*	Active
	True	H	L	L	Active
Shorted LED fault	False	H	H	Sw*	Active
	True	L	H	L	Active
Overtemperature	False	H	H	Sw*	Active
	True	L	L	L	Shutdown

*Note:
Sw = Switching
False = Condition does not exist
True = Condition does exist

Figure 23 Diagnostic Truth Table - TLD5190QV

Note: A device Overtemperature event overrules all other fault events!

10.2 Overvoltage, Open Load, Short circuit protection

The VFB pin measures the voltage on the application output and in accordance with the populated resistor divider, short to ground, open load and overvoltage thresholds are set. Refer to [Figure 24](#) for more details.

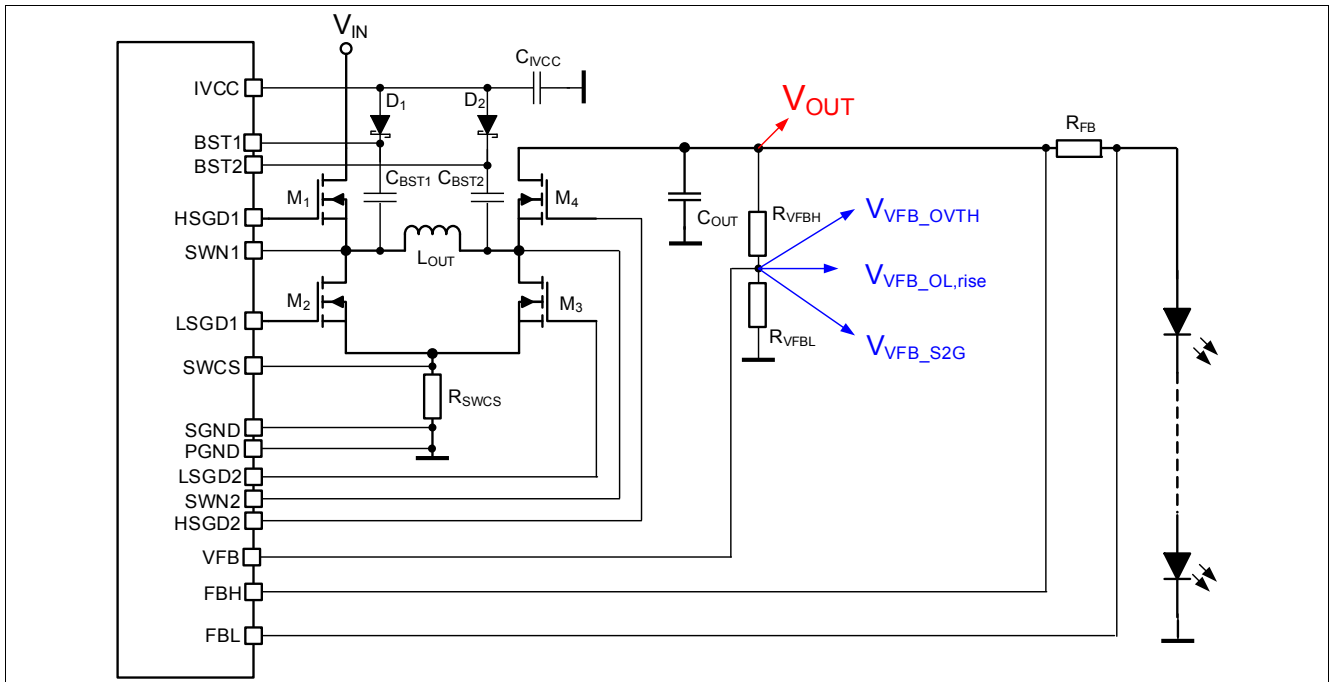

Figure 24 VFB Protection Pin - Overview

10.2.1 Short Circuit protection

The device detects a short circuit if this condition is verified:

- The pin VFB falls below the threshold voltage V_{VFB_S2G} for at least 8 clock cycles

A voltage divider between V_{OUT} , VFB pin and AGND is used to adjust the application short circuit thresholds following [Equation \(8\)](#).

$$V_{short_led} = V_{VFB_S2G} \cdot \frac{R_{VFBH} + R_{VFBL}}{R_{VFBL}} \quad (7)$$

The TLD5190QV provides an open-drain status pin, EF1, which pulls low when the short circuit is detected. The only time the FB pin will be below V_{VFB_S2G} is during start-up or if the LEDs are shorted. During start-up the TLD5190QV ignores the detection of a short circuit or an open load until the soft-start capacitor reaches 1.75V. To prevent false tripping after startup, a large enough soft-start capacitor must be used to allow the output to get up to approximately 50% of the final value.

Note: If the short circuit condition disappears, the device will re-start with the soft start routine as described in [Chapter 6.2](#).

10.2.2 Overvoltage Protection

A voltage divider between V_{OUT} , VFB pin and AGND is used to adjust the Overvoltage protection threshold (refer to [Figure 24](#)).

To fix the overvoltage protection threshold the following [Equation \(8\)](#) is used:

$$V_{OUT_OV_protected} = V_{VFB_OVTH} \cdot \frac{R_{VFBH} + R_{VFB_L}}{R_{VFB_L}} \quad (8)$$

In case of overvoltage events at the input and output, the open-drain status pin EF2 will toggle to LOW, while EF1 will stay at HIGH. After the overvoltage event disappeared the device will auto restart and the status pin EF2 will toggle to HIGH.

10.2.3 Open Load Protection

To reliably detect an open load event, two conditions will be observed:

- 1) Voltage threshold: $V_{VFB} > V_{VFB_OL,rise}$
- 2) output information: $V_{(FBH-FBL)} < V_{FBH_FBL_OL}$

The TLD5190QV provides an open-drain status pin, EF2, which pulls low when the VFB pin is above $V_{VFB_OL,rise}$ threshold and the voltage across $V_{(FBH-FBL)}$ is less than $V_{FBH_FBL_OL}$. If the open LED clamp voltage is programmed correctly using the VFB pin, then the VFB pin should never exceed 1.28V ($V_{VFBOL,fall}$ when the LEDs are connected).

After an Open Load error the TLD5190QV is autorestarting the output control accordingly to the implemented Softstart routine. An Open Load error causes an increase of the output voltage as well. An Overvoltage condition could be reported in combination with an Open Load error (in general, multiple error detection may happen if more error detection thresholds are reached during the autorestart function, as possible consequence of reactive behavior at the output node during open load).

The COMP capacitor is discharged during an Open Load condition to prevent spikes if load reconnects. This measure could artificially generate Short Circuit detections after open loads events.

10.3 Input voltage monitoring, protection and power derating

Input overvoltage and undervoltage shutdown levels can both be defined through an external resistor divider, as shown in [Figure 25](#).

Both INOVLO and EN/INUVLO pin voltages are internally compared to their respective thresholds by means of hysteretic comparators.

Neglecting the hysteresis, the following equations hold:

$$UV_{th} = \left(1 + \frac{R_1}{R_2 + R_3}\right) \cdot EN / INUVLO_{th} \quad (9)$$

$$OV_{th} = \left(1 + \frac{R_1 + R_2}{R_3}\right) \cdot INOVLO_{th} \quad (10)$$

$$P_{IN} = \frac{V_{OUT} \cdot I_{OUT}}{\eta} \quad (11)$$

$$V_{IN_boundary} = \frac{\left(\frac{V_{OUT} \cdot I_{OUT}}{I_{IN}}\right)}{\eta} \quad (12)$$

$$I_{IN} = \frac{V_{IN1} - V_{IN2}}{R_{IN}} \quad (13)$$

$$I_{OUT} = \frac{V_{FBH} - V_{FBL}}{R_{FB}} \quad (14)$$

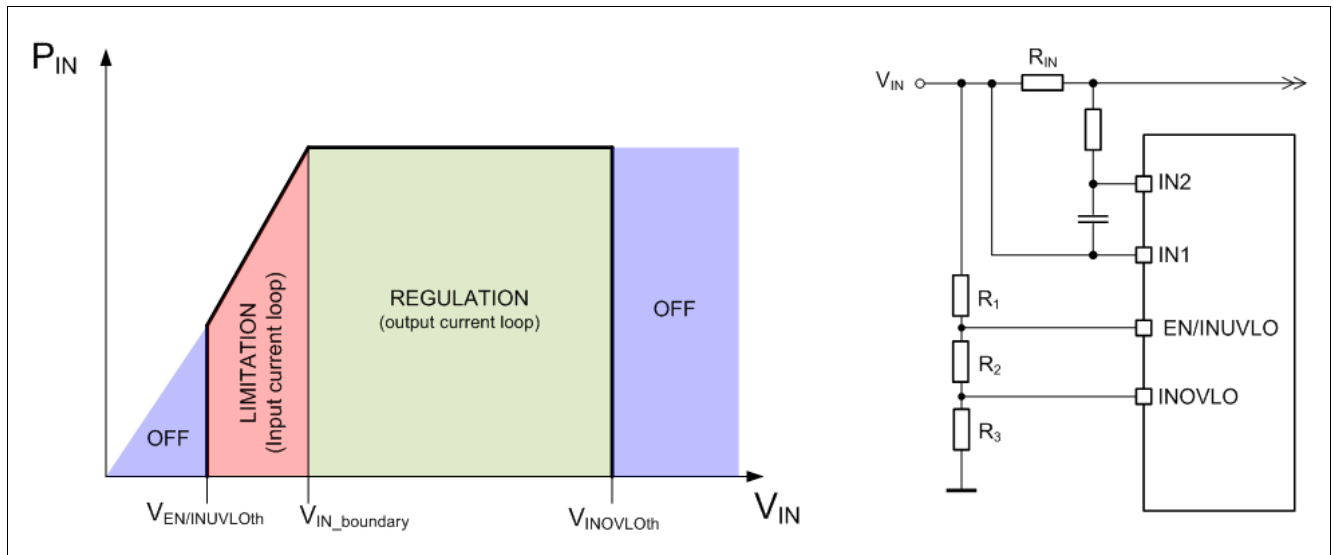

Figure 25 Input Voltage Protection

10.4 Input current Monitoring

The IINMON pin provides a linear indication of the current flowing through the input. The following [Equation \(15\)](#) is applicable:

$$V_{IINMON} = I_{IN} \cdot R_{IN} \cdot 20 \quad (15)$$

Note: If the R_{IN} value is chosen in a way that the current limitation is much bigger than the nominal input current during the application the current measurement becomes inaccurate. Best results for an accurate current measurement via the V_{IINMON} pin is to set the current limit only slightly above the specific application related nominal input current.

10.5 Output current Monitoring

The IOUTMON pin provides a linear indication of the current flowing through the LEDs. The following [Equation \(16\)](#) is applicable:

$$V_{IOUTMON} = 200 \text{ mV} + I_{OUT} \cdot R_{FB} \cdot 8 \quad (16)$$

10.6 Device Temperature Monitoring

A temperature sensor is integrated on the chip. The temperature monitoring circuit compares the measured temperature to the shutdown threshold.

If the internal temperature sensor reaches the shut-down temperature, the Gate Drivers plus the IVCC regulator are shut down as described in **Figure 26**.

The CLKOUT function is disabled during an overtemperature event and will autorestart when the device cooled down and IVCC is present again.

Note: The Device will start up with a soft start routine after a overtemperature condition disappear.

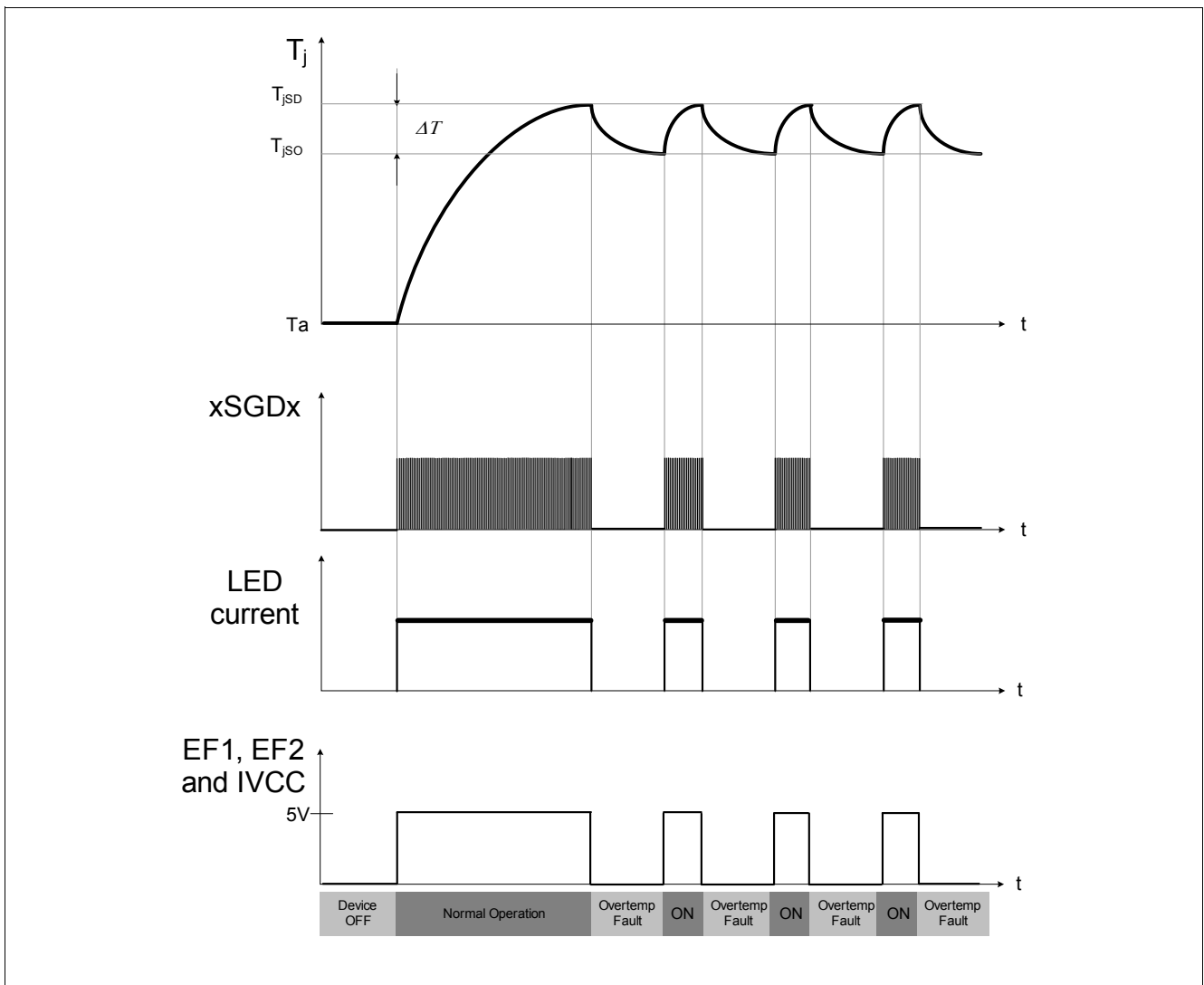

Figure 26 Device Overtemperature Protection Behavior

10.7 Electrical Characteristics
Table 10 EC Protection and Diagnosis
 $V_{IN} = 8V$ to $36V$, $T_j = -40^{\circ}C$ to $+150^{\circ}C$, all voltages with respect to AGND; (unless otherwise specified)

Parameter	Symbol	Values			Unit	Note / Test Condition	Number
		Min.	Typ.	Max.			
Short Circuit Protection							
Short to GND threshold	V_{VFB_S2G}	0.53	0.563	0.59	V	V_{VFB} decreasing;	P_10.8.1
Temperature Protection:							
Over Temperature Shutdown	$T_{j,SD}$	160	175	190	$^{\circ}C$	¹⁾	P_10.8.4
Over Temperature Shutdown Hysteresis	$T_{j,SD,hyst}$	–	10	–	$^{\circ}C$	¹⁾	P_10.8.5
Overvoltage Protection:							
VFB Over Voltage Feedback Threshold	V_{VFB_OVTH}	1.42	1.46	1.50	V		P_10.8.6
Output Over Voltage Feedback Hysteresis	$V_{VFB_OVTH,HY}$ s	25	40	58	mV	Output Voltage decreasing;	P_10.8.7
Open Load and Open Feedback Diagnostics							
Open Load rising Threshold	$V_{VFB_OL,rise}$	1.29	1.34	1.39	V	$V_{FBH-FBL} = 0 V$;	P_10.8.9
Open Load reference Voltage $V_{FBH-FBL}$	$V_{FBH_FBL_OL}$	–	15	22.5	mV	$V_{FB} = 1.4 V$;	P_10.8.10
Open Load falling Threshold	$V_{VFB_OL,fall}$	1.23	1.28	1.33	V	$V_{FBH-FBL} = 0 V$;	P_10.8.11
Input Overvoltage protection							
Input Overvoltage rising Threshold	$V_{INOVLOth}$	1.9	2	2.1	V	–	P_10.8.12
Input Overvoltage Threshold Hysteresis	$V_{INOVLO(hyst)}$	18	40	62	mV	–	P_10.8.13
Error Flags							
EF1,2 Pin Output Impedance	R_{EF12}	–	2.1	–	k Ω	¹⁾ Fault Condition $I=100\mu A$	P_10.8.14

¹⁾ Specified by design; not subject to production test.

Note: Integrated protection functions are designed to prevent IC destruction under fault conditions described in the data sheet. Fault conditions are considered as “outside” normal operating range. Protection functions are not designed for continuous repetitive operation.

11 Infineon FLAT SPECTRUM Featureset

11.1 Description

The Infineon FLAT SPECTRUM feature set has the target to minimize external additional filter circuits. The goal is to provide several beneficial concepts to provide easy adjustments for EMC improvements after the layout is already done and the HW designed.

11.2 Synchronization Function

The TLD5190QV features a SYNC input pin which can be used by a μC pin to define an oscillator switching frequency. The μC is responsible to synchronize with various devices by applying appropriate SYNC signals to the dedicated DC/DC devices in the system. Refer to [Figure 27](#)

Note: The Synchronization function can not be used when the Spread Spectrum is active.

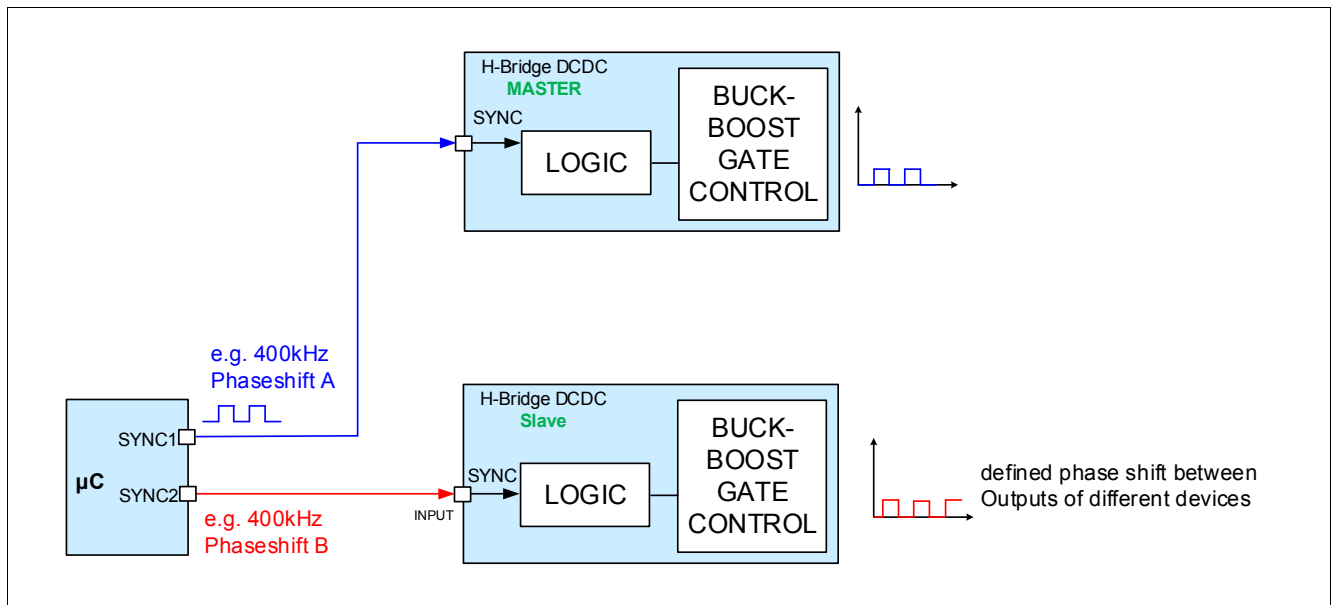

Figure 27 Synchronization Overview

11.3 CLKOUT Function

The CLKOUT pin provides an in-phase clock signal provided by the internal oscillator. This signal can be used to synchronize two devices for extending output power capability.

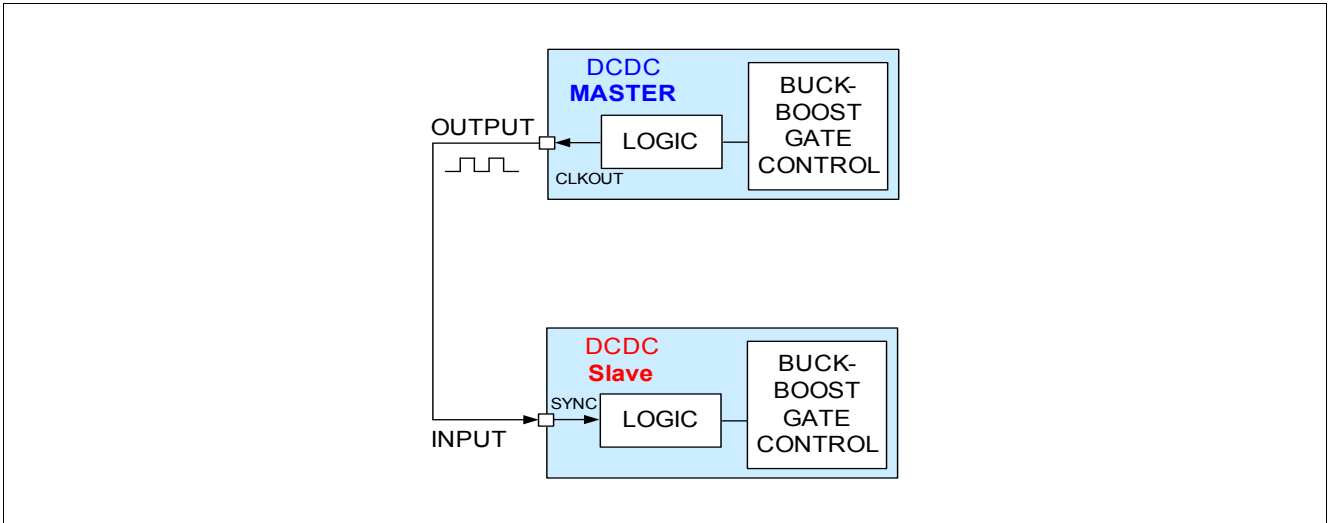

Figure 28 CLKOUT Overview

11.4 Spread Spectrum

The Spread Spectrum modulation technique significantly improves the lower frequency range of the spectrum ($f < 30\text{MHz}$).

By using the spread spectrum technique, it is possible to optimize the input filter only for the peak limits, and also pass the average limits (average emission limits are -20dB lower than the peak emission limits). By using spread spectrum, the need for low ESR input capacitors is relaxed because the input capacitor series resistor is important for the low frequency filter characteristic. This can be an economic benefit if there is a strong requirement for average limits.

The TLD5190QV features a built in Spread Spectrum function which can be enabled via an external Pin ($\text{SPREAD_SPECTRUM} = \text{HIGH}$). The modulation frequency f_{FM} , P_11.6.3 and the deviation frequency f_{dev} , P_11.6.2 are internally fixed. Refer to [Figure 29](#) for more details.

Note: The Spread Spectrum function can not be used when the synchronization pin is used.

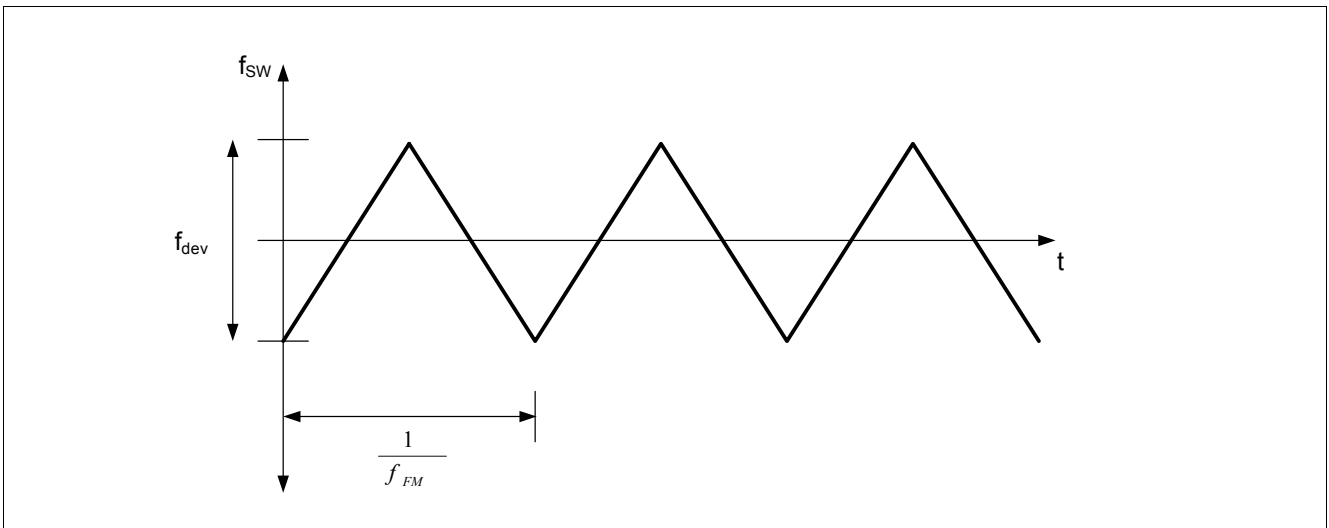

Figure 29 Spread Spectrum Overview

11.5 EMC optimized schematic

Figure 30 below displays the Application circuit with additional external components for improved EMC behavior.

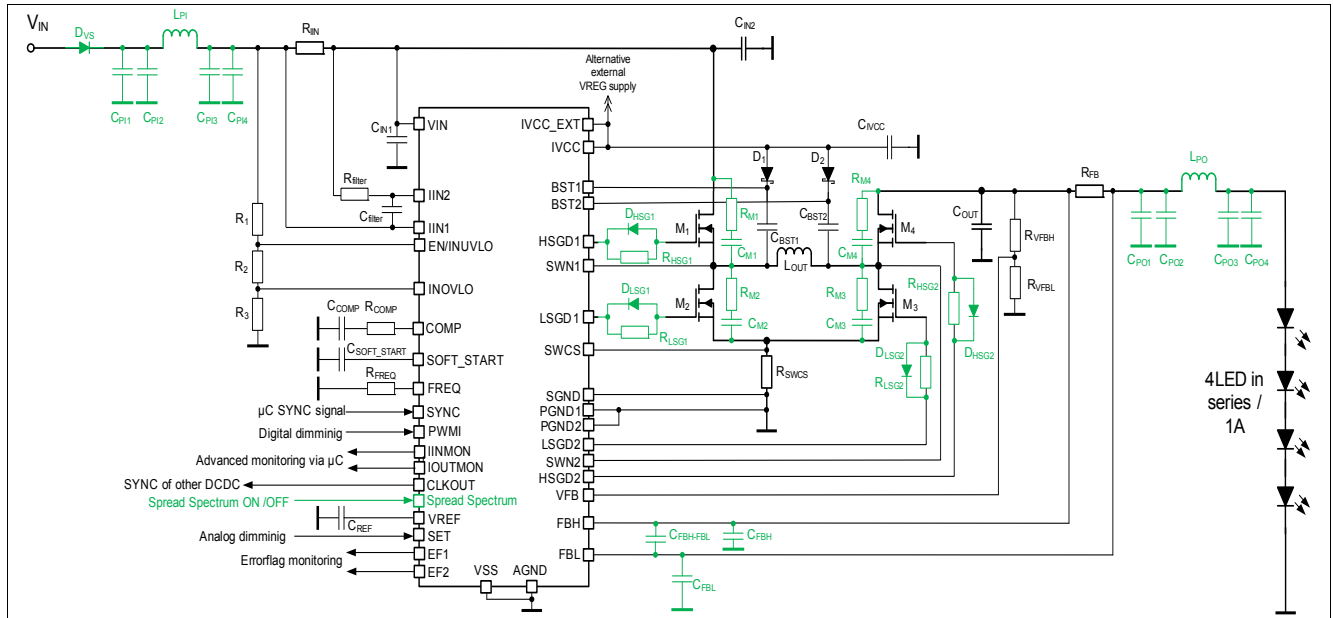

Figure 30 Application Drawing Including Additional Components for an Improved EMC Behavior

Note: The following information is given as a hint for the implementation of the device only and shall not be regarded as a description or warranty of a certain functionality, condition or quality of the device.

11.6 Electrical Characteristics

Table 11 EC Spread Spectrum
 $V_{IN} = 8V$ to $36V$, $T_j = -40^{\circ}C$ to $+150^{\circ}C$, all voltages with respect to AGND; (unless otherwise specified)

Parameter	Symbol	Values			Unit	Note / Test Condition	Number
		Min.	Typ.	Max.			
Spread Spectrum Parameters							
Frequency Deviation	f_{dev}	–	±16	–	%	¹⁾ SPREAD_SPECTRUM = HIGH;;	P_11.6.2
Frequency Modulation	f_{FM}	–	12	–	kHz	¹⁾ SPREAD_SPECTRUM = HIGH;	P_11.6.3
Input Characteristics (SPREAD_SPECTRUM)							
SPREAD_SPECTRUM Turn On Threshold	$V_{SPREAD_SPECTRUM,ON}$	2	–	–	V	–	P_11.6.5
SPREAD_SPECTRUM Turn Off Threshold	$V_{SPREAD_SPECTRUM,OFF}$	–	–	0.8	V	–	P_11.6.6
SPREAD_SPECTRUM High Input Current	$I_{SPREAD_SPECTRUM,H}$	15	30	45	μA	$V_{SPREAD_SPECTRUM} = 2.0 V$;	P_11.6.8
SPREAD_SPECTRUM Low Input Current	$I_{SPREAD_SPECTRUM,L}$	6	12	18	μA	$V_{SPREAD_SPECTRUM} = 0.8 V$;	P_11.6.9
Output Characteristics (CLKOUT)							
L level output voltage	$V_{CLKOUT(L)}$	0	–	0.4	V	$I_{CLKOUT} = -2 mA$;	P_11.6.10
H level output voltage	$V_{CLKOUT(H)}$	$V_{IVCC} - 0.4 V$	–	V_{IVCC}	V	$I_{CLKOUT} = 2 mA$;	P_11.6.11

¹⁾ Specified by design; not subject to production test.

12 Application Information

Note: The following information is given as a hint for the implementation of the device only and shall not be regarded as a description or warranty of a certain functionality, condition or quality of the device.

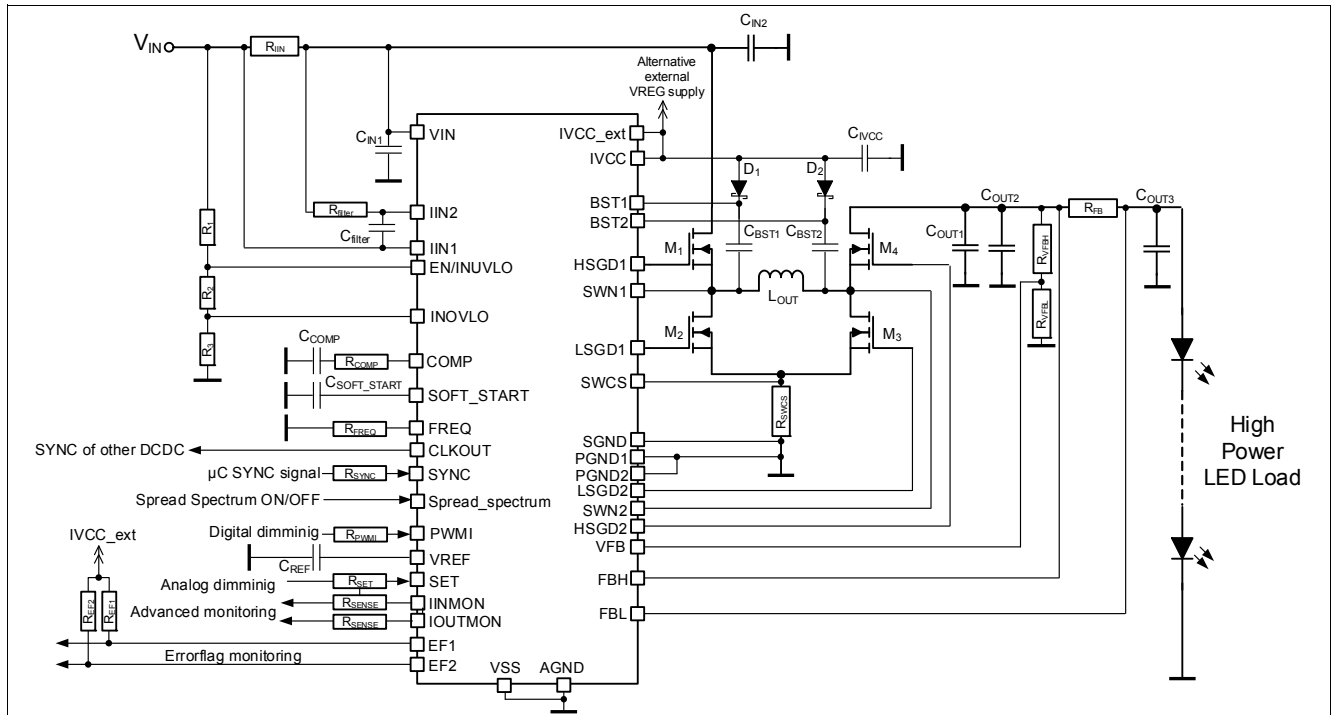

Figure 31 Application Drawing - TLD5190QV as current regulator

Table 12 BOM - TLD5190QV as current regulator ($I_{OUT} = 1A$, $f_{SW} = 300kHz$)

Reference Designator	Value	Manufacturer	Part Number	Type	Quantity
D_1, D_2	Schottky Diode	TBD	TBD	Diode	2
C_{IN1}	1 μF , 100V	EPCOS	X7R	Capacitor	1
C_{IN2}	4.7 μF , 100V	EPCOS	X7R	Capacitor	5
C_{filter}	470 nF, 6.3V	EPCOS	X7R	Capacitor	1
C_{COMP}	22 nF, 16V	EPCOS	X7R	Capacitor	1
C_{SOFT_START}	22 nF, 16V	EPCOS	X7R	Capacitor	1
C_{OUT1}	4.7 μF , 100V	EPCOS	X7R	Capacitor	3
$C_{OUT2}; C_{OUT3}; C_{REF}$	100 nF, 100V	EPCOS	X7R	Capacitor	3
C_{IV}	10 μF , 10V	EPCOS	X7R	Capacitor	1
C_{BST1}, C_{BST2}	100 nF, 16V	EPCOS	X7R	Capacitor	2
IC_1	—	Infineon	TLD5190QV	IC	1
L_{OUT}	10 μH	Coilcraft	XAL1010-103MEC	Inductor	1
R_{filter}	50 Ω , 1%	Panasonic	TBD	Resistor	1
R_{FB}	0.150 Ω , 1%	Panasonic	TBD	Resistor	1
R_{IN}	0.003 Ω , 1%	Panasonic	TBD	Resistor	1

Table 12 BOM - TLD5190QV as current regulator ($I_{OUT} = 1A, f_{SW} = 300kHz$)

Reference Designator	Value	Manufacturer	Part Number	Type	Quantity
$R_1, R_2, R_3, R_{EN}, R_{PWM1}, R_{Sense1}, R_{Sense2}, R_{SYNC}, R_{EF1}, R_{EF2}, R_{SET}$	XX k Ω , 1%	Panasonic	TBD	Resistor	10
R_{VFBL}, R_{VFBH}	1.5 k Ω , 56 k Ω , 1%	Panasonic	TBD	Resistor	2
R_{COMP}	0 Ω	Panasonic	TBD	Resistor	1
R_{FREQ}	37.4 k Ω , 1%	Panasonic	TBD	Resistor	1
R_{SWCS}	0.005 Ω , 1%	Panasonic	ERJB1CFRO5U	Resistor	1
M1, M2, M3, M4	Dual MOSFET: 100V/35m Ω , N-ch	Infineon	IPG20N10S4L-35	Transistor	2

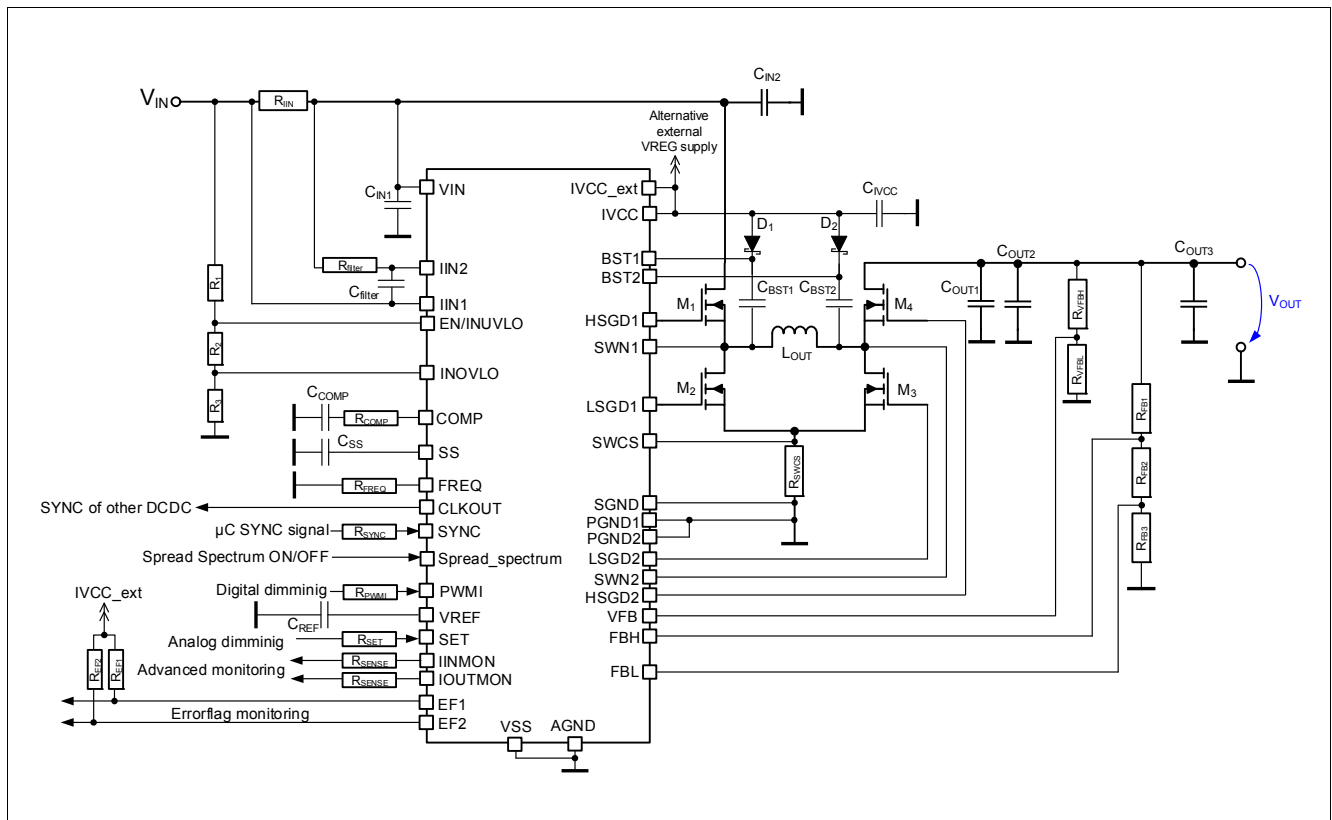

Figure 32 Application Drawing - TLD5190QV as voltage regulator

Table 13 BOM - TLD5190QV as voltage regulator ($I_{OUT} = 1A, f_{SW} = 300kHz$)

Reference Designator	Value	Manufacturer	Part Number	Type	Quantity
D_1, D_2	Schottky Diode	TBD	TBD	Diode	2
C_{IN1}	1 μ F, 100V	EPCOS	X7R	Capacitor	1
C_{IN2}	4.7 μ F, 100V	EPCOS	X7R	Capacitor	5
C_{filter}	470 nF, 6.3V	EPCOS	X7R	Capacitor	1
C_{COMP}	22 nF, 16V	EPCOS	X7R	Capacitor	1
C_{SOFT_START}	22 nF, 16V	EPCOS	X7R	Capacitor	1
C_{OUT1}	4.7 μ F, 100V	EPCOS	X7R	Capacitor	3

Table 13 BOM - TLD5190QV as voltage regulator ($I_{OUT} = 1A, f_{SW} = 300kHz$)

Reference Designator	Value	Manufacturer	Part Number	Type	Quantity
$C_{OUT2}; C_{OUT3}; C_{REF}$	100 nF, 100V	EPCOS	X7R	Capacitor	3
C_{IVCC}	10 μ F, 10V	EPCOS	X7R	Capacitor	1
C_{BST1}, C_{BST2}	100 nF, 16V	EPCOS	X7R	Capacitor	2
IC_1	—	Infineon	TLD5190QV	IC	1
L_{OUT}	10 μ H	Coilcraft	XAL1010-103MEC	Inductor	1
R_{filter}	50 Ω , 1%	Panasonic	TBD	Resistor	1
$R_{FB1}, R_{FB2}, R_{FB3}$	XX k Ω , 1%	Panasonic	TBD	Resistor	3
R_{IN}	0.003 Ω , 1%	Panasonic	TBD	Resistor	1
$R_1, R_2, R_3, R_{EN}, R_{PWM1}, R_{Sense1}, R_{Sense2}, R_{SYNC}, R_{EF1}, R_{EF2}, R_{SET}$	XX k Ω , 1%	Panasonic	TBD	Resistor	10
R_{VFB1}, R_{VFB2}	1.5 k Ω , 56 k Ω , 1%	Panasonic	TBD	Resistor	2
R_{COMP}	0 Ω	Panasonic	TBD	Resistor	1
R_{FREQ}	37.4 k Ω , 1%	Panasonic	TBD	Resistor	1
R_{swcs}	0.005 Ω , 1%	Panasonic	ERJB1CFRO5U	Resistor	1
M1, M2, M3, M4	Dual MOSFET: 100V/35m Ω , N-ch	Infineon	IPG20N10S4L-35	Transistor	2

12.1 Further Application Information

Typical Performance Characteristics of Device

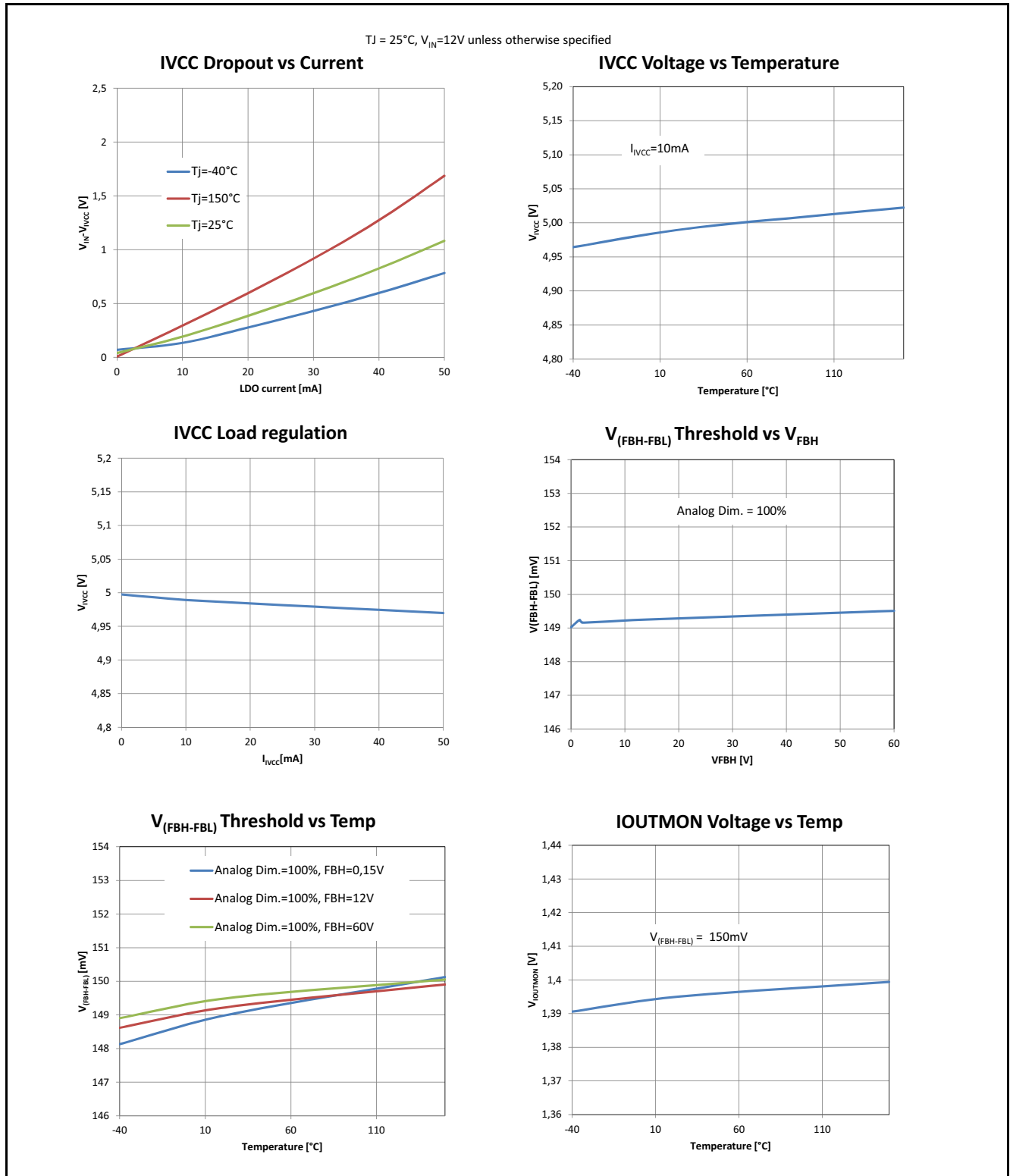

Figure 33 Characterization Diagrams 2

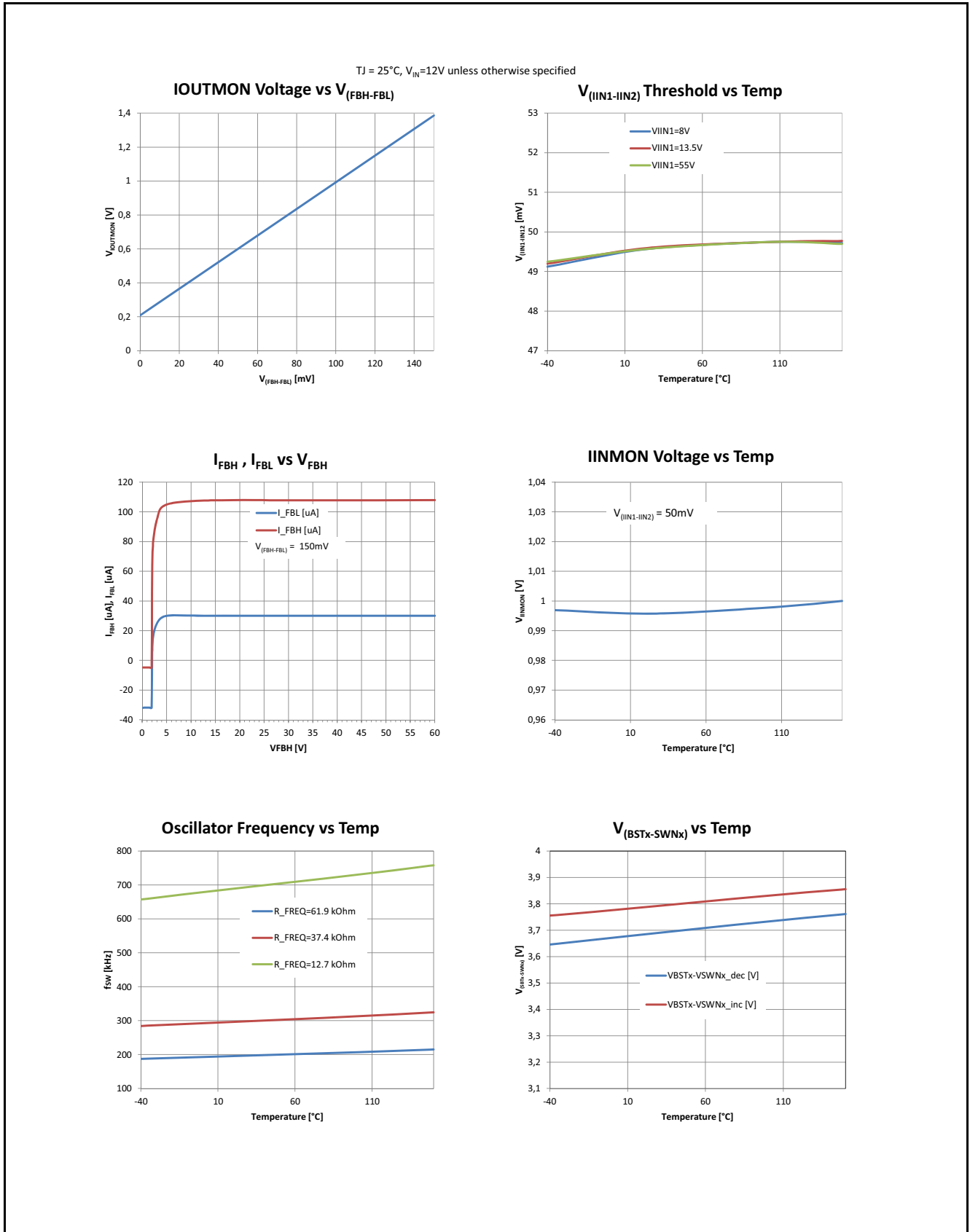

Figure 34 Characterization Diagrams 3

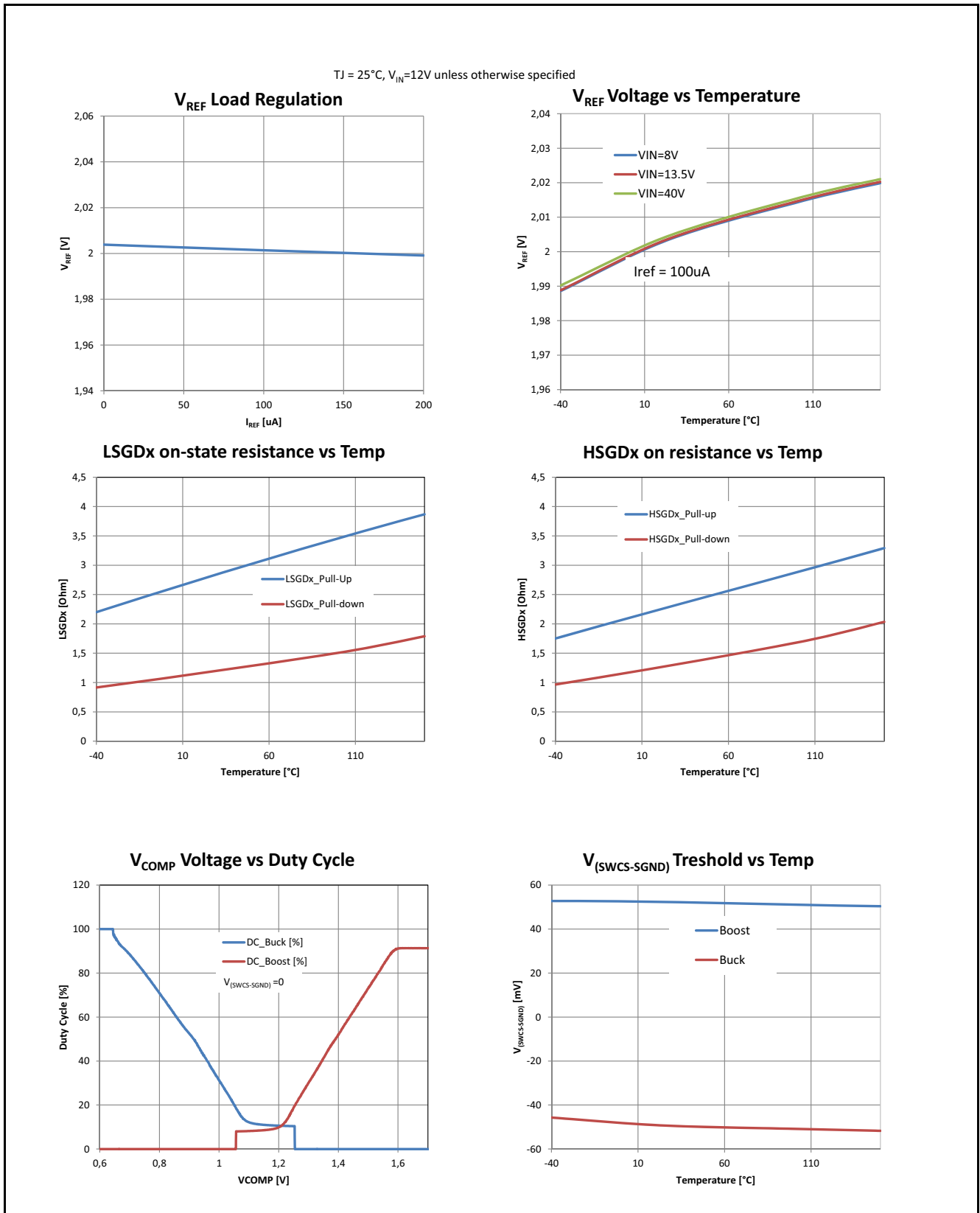

Figure 35 Characterization Diagrams 4

- For further information you may contact <http://www.infineon.com/>

14 Revision History

Revision	Date	Changes
Rev. 1.0	2016-05-20	Released Datasheet

Edition 2016-05-20

**Published by
Infineon Technologies AG
81726 Munich, Germany**

**© 2016 Infineon Technologies AG
All Rights Reserved.**

Legal Disclaimer

The information given in this document shall in no event be regarded as a guarantee of conditions or characteristics. With respect to any examples or hints given herein, any typical values stated herein and/or any information regarding the application of the device, Infineon Technologies hereby disclaims any and all warranties and liabilities of any kind, including without limitation, warranties of non-infringement of intellectual property rights of any third party.

Information

For further information on technology, delivery terms and conditions and prices, please contact the nearest Infineon Technologies Office (www.infineon.com).

Warnings

Due to technical requirements, components may contain dangerous substances. For information on the types in question, please contact the nearest Infineon Technologies Office.

Infineon Technologies components may be used in life-support devices or systems only with the express written approval of Infineon Technologies, if a failure of such components can reasonably be expected to cause the failure of that life-support device or system or to affect the safety or effectiveness of that device or system. Life support devices or systems are intended to be implanted in the human body or to support and/or maintain and sustain and/or protect human life. If they fail, it is reasonable to assume that the health of the user or other persons may be endangered.