

## 红外测温传感器 SGXV02-100-000-100

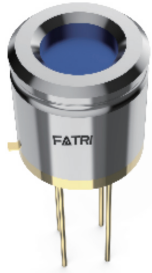

Model: SGXV02-100-000-100

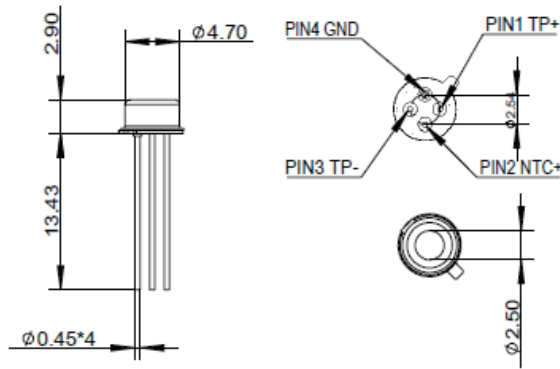

Size (Unit: mm)

### 产品特性

- 非接触表面温度测量
- 5.5um红外滤光片
- 快速响应时间
- 宽测量温度范围

### 电气

### SGXV02-100-000-100

响应率,(25°C, 500K 黑体, 1Hz)

125 V/W

探测率 (25°C, 500K 黑体, 1Hz)

0.63E08 cm · Hz<sup>1/2</sup>/W

等效噪声功率

0.44 nW · Hz<sup>1/2</sup>

热电堆电阻, 25°C

Min.

Typ.

Max.

280 kΩ

350 kΩ

420 kΩ

热电堆温度系数

0.06 %/°C

噪声电压

60 ± 2 nV/Hz<sup>1/2</sup>

时间常数

15ms

视角

112°

测量范围

-30~100°C

测温精度

0.1°C (35°C-41°C) 0.2°C (-10°C-85°C) 0.3°C (-30°C-100°C)

NTC 电阻

100 ± 1% KΩ

NTC β 值

4250 ± 1% K

### 环境

储存温度

-40~125°C

### 物理

封装形式

TO-46

### 光学特性

封装形式

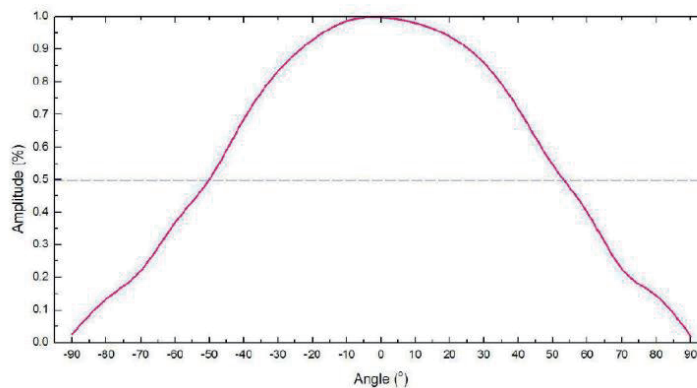

## 红外测温传感器 SGXV02-100-000-100

过滤器规格	数值	单位	描述
传播范围	5.5	um	长波通过
通过率	≥75	%	5.5-14um
阻塞传输	1	%	<5um

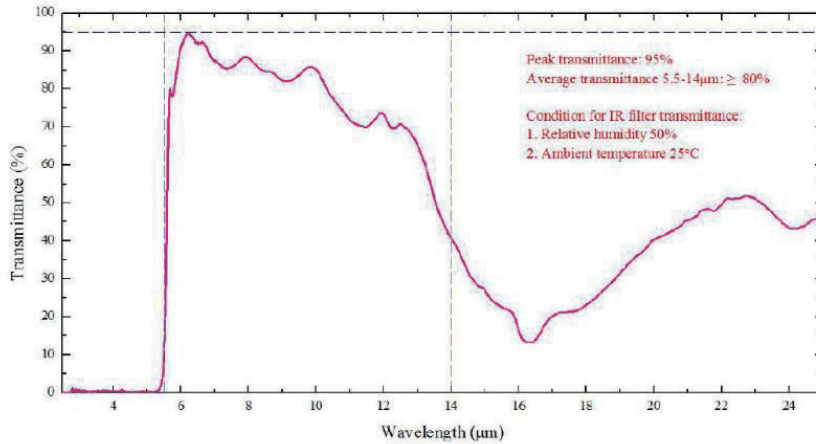

### NTC 电阻-温度

R25	100 kΩ	±1%				
B25/50	4250 K	±1%				
Temp	Min	Nom	Max	B25/T	-dT	dT
(degC)	(k ohm)	(k ohm)	(k ohm)	(K)	(degC)	(degC)
-40	4054	4251	4458	4010	-0.6	0.6
-39	3781	3962	4152	4014	-0.6	0.6
-38	3528	3695	3869	4017	-0.6	0.6
-37	3294	3447	3607	4020	-0.6	0.6
-36	3077	3218	3365	4024	-0.6	0.6
-35	2875	3005	3140	4027	-0.6	0.6
-34	2688	2807	2932	4030	-0.6	0.6
-33	2514	2624	2738	4034	-0.6	0.6
-32	2353	2454	2559	4037	-0.6	0.6
-31	2203	2296	2393	4040	-0.6	0.6
-30	2063	2149	2238	4043	-0.6	0.6
-29	1933	2012	2094	4047	-0.6	0.6
-28	1812	1885	1961	4050	-0.6	0.6
-27	1700	1767	1836	4053	-0.6	0.6
-26	1595	1656	1721	4056	-0.6	0.6
-25	1497	1554	1613	4059	-0.6	0.6
-24	1405	1458	1513	4062	-0.6	0.6
-23	1320	1369	1419	4066	-0.6	0.6
-22	1241	1286	1332	4069	-0.6	0.6
-21	1166	1208	1251	4072	-0.5	0.5
-20	1097	1135	1175	4075	-0.5	0.5
-19	1032	1068	1104	4078	-0.5	0.5
-18	971.5	1004	1038	4081	-0.5	0.5
-17	914.7	945	976.1	4084	-0.5	0.5
-16	861.7	889.6	918.3	4087	-0.5	0.5
-15	812	837.8	864.3	4090	-0.5	0.5
-14	765.4	789.3	813.8	4093	-0.5	0.5
-13	721.8	743.9	766.5	4096	-0.5	0.5
-12	680.9	701.3	722.3	4099	-0.5	0.5
-11	642.6	661.5	680.8	4102	-0.5	0.5
-10	606.6	624.1	642	4105	-0.5	0.5
-9	572.9	589	605.6	4108	-0.5	0.5
-8	541.2	556.2	571.4	4111	-0.5	0.5
-7	511.5	525.3	539.4	4113	-0.5	0.5
-6	483.5	496.3	509.4	4116	-0.5	0.5
-5	457.3	469.1	481.2	4119	-0.4	0.4
-4	432.6	443.5	454.7	4122	-0.4	0.4
-3	409.4	419.5	429.8	4125	-0.4	0.4
-2	387.5	396.9	406.4	4127	-0.4	0.4
-1	367	375.6	384.4	4130	-0.4	0.4
0	347.6	355.6	363.8	4133	-0.4	0.4
1	329.4	336.8	344.3	4136	-0.4	0.4
2	312.2	319.1	326	4138	-0.4	0.4
3	296.1	302.4	308.8	4141	-0.4	0.4
4	280.8	286.7	292.6	4144	-0.4	0.4
5	266.4	271.8	277.3	4147	-0.4	0.4
6	252.9	257.8	262.9	4149	-0.4	0.4
7	240.1	244.7	249.3	4152	-0.4	0.4

8	228	232.2	236.5	4154	-0.4	0.4
9	216.6	220.5	224.5	4157	-0.3	0.3
10	205.8	209.4	213.1	4160	-0.3	0.3
11	195.6	198.9	202.3	4162	-0.3	0.3
12	186	189	192.2	4165	-0.3	0.3
13	176.9	179.7	182.6	4167	-0.3	0.3
14	168.3	170.9	173.5	4170	-0.3	0.3
15	160.1	162.5	164.9	4172	-0.3	0.3
16	152.4	154.6	156.9	4175	-0.3	0.3
17	145.1	147.2	149.2	4177	-0.3	0.3
18	138.2	140.1	142	4180	-0.3	0.3
19	131.7	133.4	135.1	4182	-0.3	0.3
20	125.5	127	128.6	4185	-0.3	0.3
21	119.6	121	122.5	4187	-0.2	0.2
22	114	115.4	116.7	4190	-0.2	0.2
23	108.8	110	111.2	4192	-0.2	0.2
24	103.8	104.8	105.9	4194	-0.2	0.2
25	99	100	101	4197	-0.2	0.2
26	94.4	95.4	96.4	4199	-0.2	0.2
27	90.04	91.04	92.03	4201	-0.2	0.2
28	85.91	86.9	87.89	4204	-0.2	0.2
29	81.98	82.97	83.95	4206	-0.3	0.3
30	78.26	79.23	80.21	4208	-0.3	0.3
31	74.72	75.69	76.66	4210	-0.3	0.3
32	71.36	72.32	73.28	4213	-0.3	0.3
33	68.17	69.12	70.06	4215	-0.3	0.3
34	65.14	66.07	67.01	4217	-0.3	0.3
35	62.26	63.18	64.1	4219	-0.3	0.3
36	59.52	60.42	61.34	4221	-0.3	0.3
37	56.92	57.81	58.71	4223	-0.4	0.4
38	54.44	55.31	56.2	4226	-0.4	0.4
39	52.08	52.94	53.81	4228	-0.4	0.4
40	49.84	50.68	51.54	4230	-0.4	0.4
41	47.7	48.53	49.37	4232	-0.4	0.4
42	45.67	46.49	47.31	4234	-0.4	0.4
43	43.73	44.53	45.34	4236	-0.4	0.4
44	41.89	42.67	43.47	4238	-0.4	0.4
45	40.13	40.9	41.68	4240	-0.5	0.5
46	38.46	39.21	39.98	4242	-0.5	0.5
47	36.86	37.6	38.35	4244	-0.5	0.5
48	35.34	36.06	36.8	4246	-0.5	0.5
49	33.89	34.6	35.31	4248	-0.5	0.5
50	32.5	33.19	33.9	4250	-0.5	0.5
51	31.18	31.86	32.55	4252	-0.5	0.5
52	29.92	30.58	31.26	4254	-0.5	0.5
53	28.72	29.36	30.02	4256	-0.6	0.6
54	27.57	28.2	28.85	4258	-0.6	0.6
55	26.47	27.09	27.72	4259	-0.6	0.6
56	25.42	26.03	26.64	4261	-0.6	0.6
57	24.42	25.01	25.61	4263	-0.6	0.6
58	23.46	24.04	24.63	4265	-0.6	0.6
59	22.55	23.11	23.69	4267	-0.6	0.6
60	21.67	22.22	22.78	4269	-0.7	0.7
61	20.83	21.37	21.92	4270	-0.7	0.7

## 红外测温传感器 SGXV02-100-000-100

### NTC 电阻-温度

62	20.03	20.56	21.1	4272	-0.7	0.7
63	19.27	19.78	20.31	4274	-0.7	0.7
64	18.54	19.04	19.55	4276	-0.7	0.7
65	17.84	18.32	18.82	4277	-0.7	0.7
66	17.16	17.64	18.13	4279	-0.7	0.7
67	16.52	16.99	17.46	4281	-0.7	0.7
68	15.91	16.36	16.83	4282	-0.8	0.8
69	15.32	15.76	16.21	4284	-0.8	0.8
70	14.75	15.18	15.63	4286	-0.8	0.8
71	14.21	14.63	15.07	4287	-0.8	0.8
72	13.69	14.1	14.53	4289	-0.8	0.8
73	13.19	13.6	14.01	4290	-0.8	0.8
74	12.72	13.11	13.51	4292	-0.9	0.9
75	12.26	12.64	13.04	4293	-0.9	0.9
76	11.82	12.19	12.58	4295	-0.9	0.9
77	11.4	11.76	12.14	4296	-0.9	0.9
78	11	11.35	11.72	4298	-0.9	0.9
79	10.61	10.96	11.31	4299	-0.9	0.9
80	10.24	10.58	10.92	4301	-0.9	0.9
81	9.88	10.21	10.55	4302	-1	1
82	9.537	9.859	10.19	4304	-1	1
83	9.208	9.522	9.846	4305	-1	1
84	8.891	9.198	9.514	4307	-1	1
85	8.587	8.887	9.195	4308	-1	1
86	8.295	8.587	8.889	4309	-1	1
87	8.014	8.299	8.594	4311	-1	1.1
88	7.744	8.022	8.31	4312	-1.1	1.1
89	7.485	7.756	8.037	4313	-1.1	1.1
90	7.235	7.5	7.774	4315	-1.1	1.1
91	6.995	7.254	7.521	4316	-1.1	1.1
92	6.764	7.016	7.277	4317	-1.1	1.1
93	6.542	6.788	7.043	4319	-1.1	1.1
94	6.328	6.568	6.817	4320	-1.2	1.2
95	6.122	6.357	6.6	4321	-1.2	1.2
96	5.924	6.153	6.39	4322	-1.2	1.2
97	5.733	5.957	6.188	4323	-1.2	1.2
98	5.549	5.768	5.994	4325	-1.2	1.2
99	5.372	5.586	5.807	4326	-1.2	1.2
100	5.202	5.41	5.626	4327	-1.3	1.3
101	5.038	5.241	5.452	4328	-1.3	1.3
102	4.879	5.078	5.284	4329	-1.3	1.3
103	4.727	4.921	5.122	4330	-1.3	1.3
104	4.58	4.769	4.966	4331	-1.3	1.3
105	4.438	4.623	4.815	4332	-1.3	1.3
106	4.301	4.482	4.669	4334	-1.4	1.4
107	4.17	4.346	4.529	4335	-1.4	1.4
108	4.042	4.215	4.394	4336	-1.4	1.4
109	3.92	4.088	4.263	4337	-1.4	1.4
110	3.801	3.966	4.137	4338	-1.4	1.4
111	3.687	3.848	4.015	4339	-1.4	1.5
112	3.577	3.734	3.897	4340	-1.5	1.5
113	3.471	3.624	3.784	4340	-1.5	1.5
114	3.368	3.518	3.674	4341	-1.5	1.5
115	3.269	3.415	3.568	4342	-1.5	1.5

116	3.173	3.316	3.465	4343	-1.5	1.5
117	3.08	3.22	3.366	4344	-1.5	1.6
118	2.991	3.128	3.27	4345	-1.6	1.6
119	2.905	3.038	3.178	4346	-1.6	1.6
120	2.821	2.952	3.088	4347	-1.6	1.6
121	2.74	2.868	3.002	4347	-1.6	1.6
122	2.662	2.787	2.918	4348	-1.6	1.6
123	2.587	2.709	2.837	4349	-1.7	1.7
124	2.514	2.634	2.758	4350	-1.7	1.7
125	2.444	2.561	2.683	4351	-1.7	1.7

### V-T 数据

V-T Form (35° C-41° C)

T\_AMB=22.3°C

T_OBJ	Vout	T_OBJ	Vout	T_OBJ	Vout	T_OBJ	Vout	T_OBJ	Vout	T_OBJ	Vout
35	1.082	36.1	1.184	37.1	1.277	38.1	1.370	39.1	1.463	40.1	1.555
35.1	1.091	36.2	1.193	37.2	1.286	38.2	1.379	39.2	1.472	40.2	1.565
35.2	1.100	36.3	1.202	37.3	1.295	38.3	1.388	39.3	1.481	40.3	1.574
35.3	1.110	36.4	1.212	37.4	1.305	38.4	1.398	39.4	1.490	40.4	1.583
35.4	1.119	36.5	1.221	37.5	1.314	38.5	1.407	39.5	1.500	40.5	1.593
35.5	1.128	36.6	1.230	37.6	1.323	38.6	1.416	39.6	1.509	40.6	1.602
35.6	1.137	36.7	1.240	37.7	1.333	38.7	1.425	39.7	1.518	40.7	1.611
35.7	1.147	36.8	1.249	37.8	1.342	38.8	1.435	39.8	1.528	40.8	1.621
35.8	1.156	36.9	1.258	37.9	1.351	38.9	1.444	39.9	1.537	40.9	1.630
35.9	1.165	37	1.268	38	1.360	39	1.453	40	1.546	41	1.639