

# AS1109

Preliminary  
Product Brief

## Constant-Current, 8-Bit LED Driver with Diagnostics

### 1 General Description

The AS1109 was designed to drive up to 8 LEDs through a fast serial interface and features 8 output constant current drivers and an on-chip diagnostic read-back function.

The high clock-frequency (up to 30MHz), adjustable output current, and flexible serial interface makes the device perfectly suited for high-volume transmission applications.

Output current is adjustable (up to 100mA/channel) using an external resistor (R<sub>EXT</sub>).

The serial interface includes an integrated shift register with Schmitt trigger inputs allows display data to be shifted-in. Additionally, an internal data register stores the currently displayed data.

The device features integrated diagnostics for over-temperature, open-LED, and shorted-LED conditions. Integrated shift registers store global fault status information during load as well as the detailed temperature/open-LED/shorted-LED diagnostics results.

The AS1109 also features a low-current diagnostic mode to minimize display flicker during fault testing.

The AS1109 is available in a 16-pin SOIC-150 package and the 16-pin SSOP Package.

### 2 Key Features

- 8 Constant-Current Output Channels
- Excellent Output Current Accuracy
  - Between Channels: <math>\leq \pm 2\%</math>
  - Between AS1109 Devices: <math>\leq \pm 2\%</math>
- Output Current Per Channel: 0.5 to 100mA
- Controlled In-Rush Current
- Over-Temperature, Open-LED, Shorted-LED Diagnostics Functions
- Low-Current Test Mode
- Global Fault Monitoring
- Low Shutdown Mode Current: 10 $\mu$ A
- Fast Serial Interface: 30MHz
- Cascaded Configuration
- Extremely Fast Output Drivers Suitable for PWM
- 16-pin SOIC-150 and 16-pin SSOP Package

### 3 Applications

The device is ideal for fixed- or slow-rolling displays using static or multiplexed LED matrix and dimming functions, large LED matrix displays, mixed LED display and switch monitoring, displays in elevators, public transports (underground, trains, buses, taxis, airplanes, etc.), large displays in stadiums and public areas, price indicators in retail stores, promotional panels, bar-graph displays, industrial controller displays, white good panels, emergency light indicators, and traffic signs.

Figure 1. Main Diagram and Pin Assignments

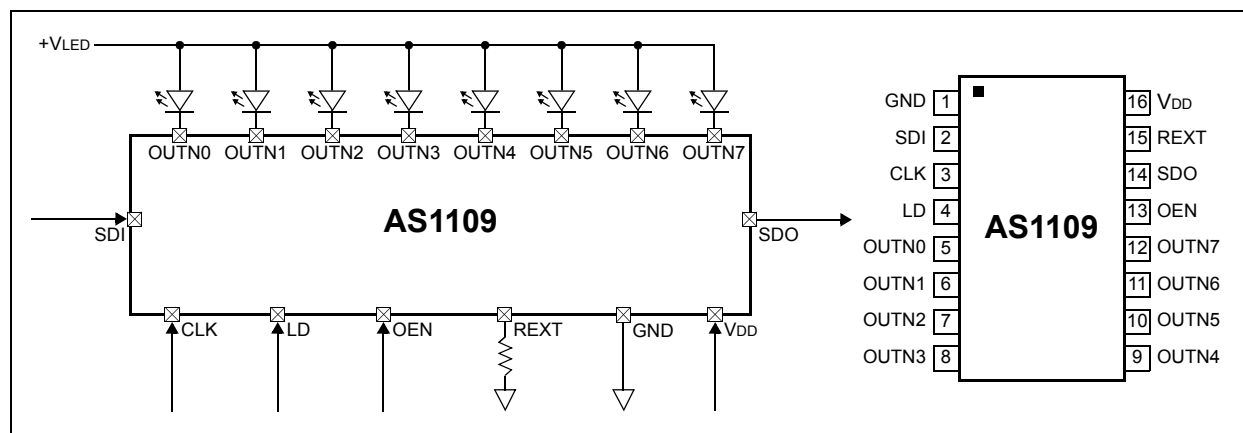

## Copyrights

Copyright © 1997-2006, austriamicrosystems AG, Schloss Premstaetten, 8141 Unterpremstaetten, Austria-Europe. Trademarks Registered ®. All rights reserved. The material herein may not be reproduced, adapted, merged, translated, stored, or used without the prior written consent of the copyright owner.

All products and companies mentioned are trademarks or registered trademarks of their respective companies.

## Disclaimer

Devices sold by austriamicrosystems AG are covered by the warranty and patent indemnification provisions appearing in its Term of Sale. austriamicrosystems AG makes no warranty, express, statutory, implied, or by description regarding the information set forth herein or regarding the freedom of the described devices from patent infringement. austriamicrosystems AG reserves the right to change specifications and prices at any time and without notice. Therefore, prior to designing this product into a system, it is necessary to check with austriamicrosystems AG for current information. This product is intended for use in normal commercial applications. Applications requiring extended temperature range, unusual environmental requirements, or high reliability applications, such as military, medical life-support or life-sustaining equipment are specifically not recommended without additional processing by austriamicrosystems AG for each application. For shipments of less than 100 parts the manufacturing flow might show deviations from the standard production flow, such as test flow or test location.

The information furnished here by austriamicrosystems AG is believed to be correct and accurate. However, austriamicrosystems AG shall not be liable to recipient or any third party for any damages, including but not limited to personal injury, property damage, loss of profits, loss of use, interruption of business or indirect, special, incidental or consequential damages, of any kind, in connection with or arising out of the furnishing, performance or use of the technical data herein. No obligation or liability to recipient or any third party shall arise or flow out of austriamicrosystems AG rendering of technical or other services.

## Contact Information

### Headquarters

austriamicrosystems AG  
A-8141 Schloss Premstaetten, Austria

Tel: +43 (0) 3136 500 0

Fax: +43 (0) 3136 525 01

e-mail: [info@austriamicrosystems.com](mailto:info@austriamicrosystems.com)

For Sales Offices, Distributors and Representatives, please visit:

<http://www.austriamicrosystems.com>

*austriamicrosystems* – a leap ahead