

RECOMMENDED PCB LAYOUT  
(Tolerance=±0.05)

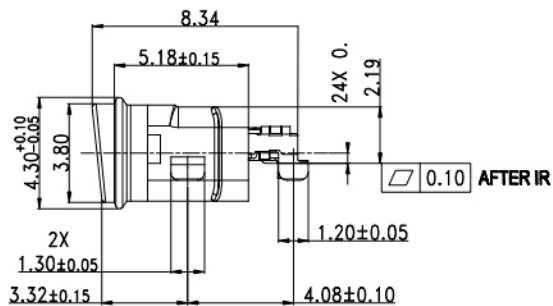

- NOTES:
- ELECTRICAL:
    - CONTACT CURRENT RATING 5.0A FOR VBUS AND GND(PINS A4 A9 B4 B9)
    - INSULATION RESISTANCE: 100 MEGAOHMS MIN. AT 250VDC.
    - DIELECTRIC WITHSTANDING VOLTAGE: 100VAC MIN.
    - LOW CONTACT RESISTANCE: INITIAL 40mΩ MAX. AFTER 50mΩ MAX.
  - MECHANICAL CHARACTERISTICS:
    - INSERTION FORCE: 5N~20N.
    - EXTRACTION FORCE: 8N~20N FORM 1 TO 1000CYCLES. 6~20N FORM 1001 TO 10000CYCLES.
    - DURABILITY: 10,000 MATING CYCLES
    - OPERATING TEMPERATURE: -55°C TO +85°C
  - COPLANARITY: 0.08MAX.
  - WATERPROOF GRADE: IPX7

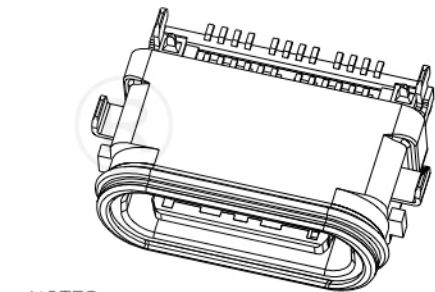

G-Switch Electronic Technology CO.,Ltd.

Unless otherwise specified, Tolerance:  
 X. ±0.30  
 X.x ±0.20  
 X.xx ±0.15  
 X.xxx ±0.10  
 Angles ±3°

DESIGN 陈锋枫 DATE 2018.05.29  
 CHECKED DATE  
 APPROVED DATE  
<http://www.dg-switch.com>  
 TEL: 0769-82388879

TITLE:  
 GT-USB-7026  
 REV.: X1 SCALE: 4:1 UNIT: mm  
 SIZE: A4 SHEET: 1/1