

Low Voltage 1:18 Clock Distribution Chip

Features

- LVC MOS/LVTTL Clock Input
- 2.5V LVC MOS Outputs for Pentium II™ Microprocessor Support
- 150pS Maximum Targeted Output-to-Output Skew
- Maximum Output Frequency of 250MHz @ 3.3 V_{CC}
- 32-Lead TQFP and LQFP Packaging
- Single 3.3V or 2.5V Supply.
- Pin and Function compatible to MPC942C.

Functional Description

The PCS2I9942C is a 1:18 low voltage clock distribution chip with 2.5V or 3.3V LVC MOS output capabilities. The device is offered in two versions; the PCS2I9942C hPcs an LVC MOS input clock while the PCS2I9942P hPcs an LVPECL input clock. The 18 outputs are 2.5V or 3.3V LVC MOS compatible and feature the drive strength to drive 50Ω series or parallel terminated transmission lines. With output-to-output skews of 200pS, the PCS2I9942C is ideal Pcs a clock distribution chip for the most demanding of synchronous systems. The 2.5V outputs also make the

device ideal for supplying clocks for a high performance Pentium II™ microprocessor based PC design.

With a low output impedance ($\approx 12\Omega$), in both the HIGH and LOW logic states, the output buffers of the PCS2I9942C are ideal for driving series terminated transmission lines. With an output impedance of 12Ω, the PCS2I9942C can drive two series terminated transmission lines from each output. This capability gives the PCS2I9942C an effective fanout of 1:36. The PCS2I9942C provides enough copies of low skew clocks for most high performance synchronous systems.

The LVC MOS/LVTTL input of the PCS2I9942C provides a more standard LVC MOS interface. The OE pins will place the outputs into a high impedance state. The OE pin hPcs an internal pullup resistor.

The PCS2I9942C is a single supply device. The V_{CC} power pins require either 2.5V or 3.3V. The 32-lead TQFP and LQFP package is chosen to optimize performance, board space and cost of the device. The 32-lead TQFP hPcs a 7x7mm² body size with a conservative 0.8mm pin spacing.

*Pentium II is a trademark of Intel Corporation

rev 0.3

Block Diagram

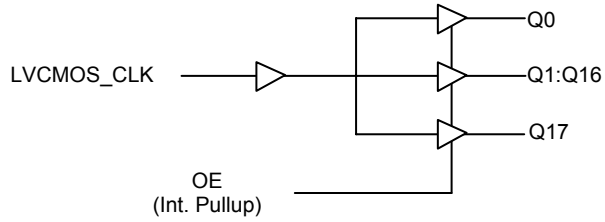
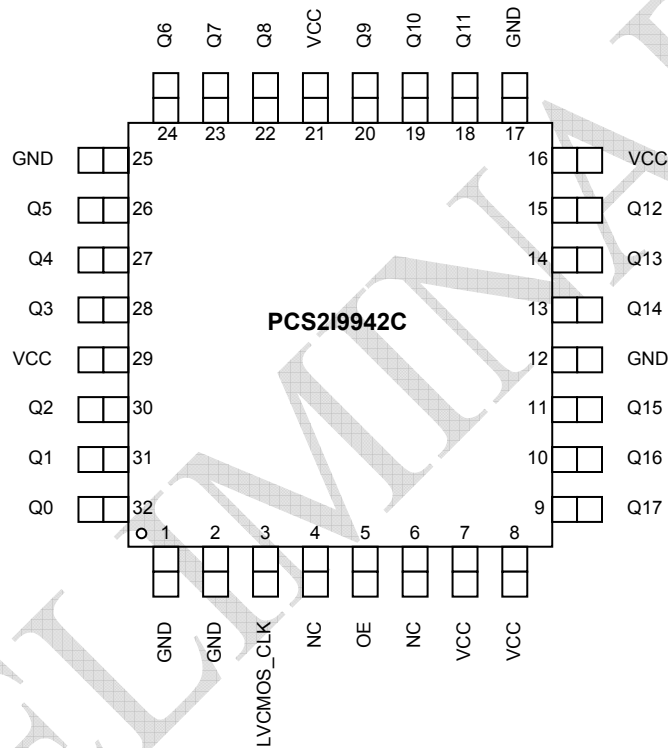

Table 1. Function Table

OE	Output
0	HIGH IMPEDANCE
1	OUTPUTS ENABLED

Pin Diagram



rev 0.3

Table 2. Pin Configuration

Pin #	Pin Name	I/O	Type	Function
1,2,12,17,25	GND	Supply	Ground	
3	LVC MOS_CLK	Input	LVC MOS	LVC MOS Clock Input
4,6	NC			No Connect
5	OE	Input	LVC MOS	Outputs are enabled, when OE is high and are tri-stated, when OE is made low.
7,8,16,21,29	VCC	Supply	VCC	Positive power supply
9-11	Q17-Q15	Output	LVC MOS	Clock outputs
13-15	Q14-Q12	Output	LVC MOS	Clock outputs
18-20	Q11-Q9	Output	LVC MOS	Clock outputs
22-24	Q8-Q6	Output	LVC MOS	Clock outputs
26-28	Q5-Q3	Output	LVC MOS	Clock outputs
30-32	Q2-Q0	Output	LVC MOS	Clock outputs

Table 3. Absolute Maximum Rating¹

Symbol	Parameter	Min	Max	Unit
V _{CC}	Supply Voltage	-0.3	3.6	V
V _I	Input Voltage	-0.3	V _{CC} + 0.3	V
I _{IN}	Input Current		±20	mA
T _{Stor}	Storage Temperature Range	-40	125	°C

Note: 1 These are stress ratings only and are not implied for functional use. Exposure to absolute maximum ratings for prolonged periods of time may affect device reliability.

Table 4. DC Characteristics (T_A = -40° to +85°C, V_{CC} = 2.5V ± 5%)

Symbol	Characteristic	Min	Typ	Max	Unit	Condition
V _{IH}	Input HIGH Voltage	2.0		V _{CCI}	V	
V _{IL}	Input LOW Voltage			0.8	V	
V _{OH}	Output HIGH Voltage	2.0			V	I _{OH} = -16 mA
V _{OL}	Output LOW Voltage			0.5	V	I _{OL} = 16 mA
I _{IN}	Input Current			±200	µA	
C _{IN}	Input Capacitance		4.0		pF	
C _{PD}	Power Dissipation Capacitance		14		pF	Per Output
Z _{OUT}	Output Impedance		12		Ω	
I _{CC}	Maximum Quiescent Supply Current		0.5		mA	

rev 0.3

Table 5. AC Characteristics ($T_A = -40^\circ$ to $+85^\circ\text{C}$, $V_{CC} = 2.5\text{V} \pm 5\%$)

Symbol	Characteristic	Min	Typ	Max	Unit	Condition
F_{max}	Maximum Frequency			200	MHz	
t_{PLH}	Propagation Delay ¹	1.5		2.8	nS	
$t_{sk(o)}$	Output-to-output Skew	Within one bank		150	pS	
		Any output, Any Bank		350		
$t_{sk(pr)}$	Part-to-Part Skew ^{1, 2}			1.3	nS	
$t_{sk(pr)}$	Part-to-Part Skew ^{1, 3}			600	pS	
d_t	Duty Cycle	45		55	%	
t_r, t_f	Output Rise/Fall Time	0.2		1.0	nS	

Note: 1. Tested using standard input levels, production tested @ 133 MHz.

2. Across temperature and voltage ranges, includes output skew.

3. For a specific temperature and voltage, includes output skew.

Table 6. DC Characteristics ($T_A = -40^\circ$ to $+85^\circ\text{C}$, $V_{CC} = 3.3\text{V} \pm 5\%$)

Symbol	Characteristic	Min	Typ	Max	Unit	Condition
V_{IH}	Input HIGH Voltage	2.4		V_{CCI}	V	
V_{IL}	Input LOW Voltage			0.8	V	
V_{OH}	Output HIGH Voltage	2.4			V	$I_{OH} = -20\text{ mA}$
V_{OL}	Output LOW Voltage			0.5	V	$I_{OL} = 20\text{ mA}$
I_{IN}	Input Current			± 200	μA	
C_{IN}	Input Capacitance		4.0		pF	
C_{PD}	Power Dissipation Capacitance		14		pF	Per Output
Z_{OUT}	Output Impedance		12		Ω	
I_{CC}	Maximum Quiescent Supply Current		0.5		mA	

Table 7. AC Characteristics ($T_A = -40^\circ$ to $+85^\circ\text{C}$, $V_{CC} = 3.3\text{V} \pm 5\%$)

Symbol	Characteristic	Min	Typ	Max	Unit	Condition
F_{max}	Maximum Frequency			250	MHz	
t_{PLH}	Propagation Delay ¹	1.3		2.3	nS	
$t_{sk(o)}$	Output-to-output Skew	Within one bank		150	pS	
		Any Output, Any Bank		350		
$t_{sk(pr)}$	Part-to-Part Skew ^{1, 2}			1.0	nS	
$t_{sk(pr)}$	Part-to-Part Skew ^{1, 3}			500	pS	
d_t	Duty Cycle	45		55	%	
t_r, t_f	Output Rise/Fall Time	0.2		1.0	nS	

Note: 1. Tested using standard input levels, production tested @ 133 MHz.

2. Across temperature and voltage ranges, includes output skew.

3. For a specific temperature and voltage, includes output skew.

Power Consumption of the PCS2I9942C and Thermal Management

The PCS2I9942C AC specification is guaranteed for the entire operating frequency range up to 250MHz. The PCS2I9942C power consumption and the Pcssociated long-term reliability may decrePcse the maximum frequency limit, depending on operating conditions such Pcs clock frequency, supply voltage, output loading, ambient temperature, vertical convection and thermal conductivity of package and board. This section describes the impact of these parameters on the junction temperature and gives a guideline to estimate the PCS2I9942C die junction temperature and the Pcssociated device reliability.

Table 8. Die junction temperature and MTBF

Junction temperature (°C)	MTBF (Years)
100	20.4
110	9.1
120	4.2
130	2.0

IncrePcsed power consumption will increPcse the die junction temperature and impact the device reliability (MTBF). According to the system-defined tolerable MTBF, the die junction temperature of the PCS2I9942C needs to be controlled and the thermal impedance of the board/package should be optimized. The power dissipated in the PCS2I9942C is represented in equation1.

Where I_{CCQ} is the static current consumption of the PCS2I9942C, C_{PD} is the power dissipation capacitance per output, $(M)\Sigma C_L$ represents the external capacitive output load, N is the number of active outputs (N is always 12 in cPcse of the PCS2I9942C). The PCS2I9942C supports driving transmission lines to maintain high signal integrity and tight timing parameters. Any transmission line will hide the lumped capacitive load at the end of the board trace, therefore, ΣC_L is zero for controlled transmission line systems and can be eliminated from equation 1. Using parallel termination output termination results in equation 2 for power dissipation.

In equation 2, P stands for the number of outputs with a parallel or thevenin termination. V_{OL} , I_{OL} , V_{OH} and I_{OH} are a function of the output termination technique and DC_Q is the clock signal duty cycle. If transmission lines are used ΣC_L is zero in equation 2 and can be eliminated. In general, the use of controlled transmission line techniques eliminates the impact of the lumped capacitive loads at the end lines and greatly reduces the power dissipation of the device. Equation 3 describes the die junction temperature T_J Pcs a function of the power consumption.

Where R_{thja} is the thermal impedance of the package (junction to ambient) and T_A is the ambient temperature. According to Table 8, the junction temperature can be used to estimate the long-term device reliability. Further, combining equation 1 and equation 2 results in a maximum operating frequency for the PCS2I9942C in a series terminated transmission line system, equation 4.

rev 0.3

$$P_{TOT} = \left[I_{CCQ} + V_{CC} \cdot f_{CLOCK} \cdot \left(N \cdot C_{PD} + \sum_M C_L \right) \right] \cdot V_{CC} \tag{Equation 1}$$

$$P_{TOT} = V_{CC} \cdot \left[I_{CCQ} + V_{CC} \cdot f_{CLOCK} \cdot \left(N \cdot C_{PD} + \sum_M C_L \right) \right] + \sum_P \left[DC_Q \cdot I_{OH} (V_{CC} - V_{OH}) + (1 - DC_Q) \cdot I_{OL} \cdot V_{OL} \right] \tag{Equation 2}$$

$$T_J = T_A + P_{TOT} \cdot R_{thja} \tag{Equation 3}$$

$$f_{CLOCKMAX} = \frac{1}{C_{PD} \cdot N \cdot V_{CC}^2} \cdot \left[\frac{T_{J,MAX} - T_A}{R_{thja}} - (I_{CCQ} \cdot V_{CC}) \right] \tag{Equation 4}$$

T_{J,MAX} should be selected according to the MTBF system requirements and Table 8. R_{thja} can be derived from Table 9. The R_{thja} represent data bPcsed on 1S2P boards, using 2S2P boards will result in a lower thermal impedance than indicated below.

If the calculated maximum frequency is below 350 MHz, it becomes the upper clock speed limit for the given application conditions. The following eight derating charts describe the safe frequency operation range for the PCS2I9942C. The charts were calculated for a maximum tolerable die junction temperature of 110°C (120°C), corresponding to an estimated MTBF of 9.1 years (4 years), a supply voltage of 3.3V and series terminated transmission line or capacitive loading. Depending on a given set of these operating conditions and the available device convection a decision on the maximum operating frequency can be made.

Table 9. Thermal package impedance of the 32LQFP

Convection, LFPM	R _{thja} (1P2S board), °C/W	R _{thja} (2P2S board), °C/W
Still air	86	61
100 lfpm	76	56
200 lfpm	71	54
300 lfpm	68	53
400 lfpm	66	52
500 lfpm	60	49

32-lead LQFP

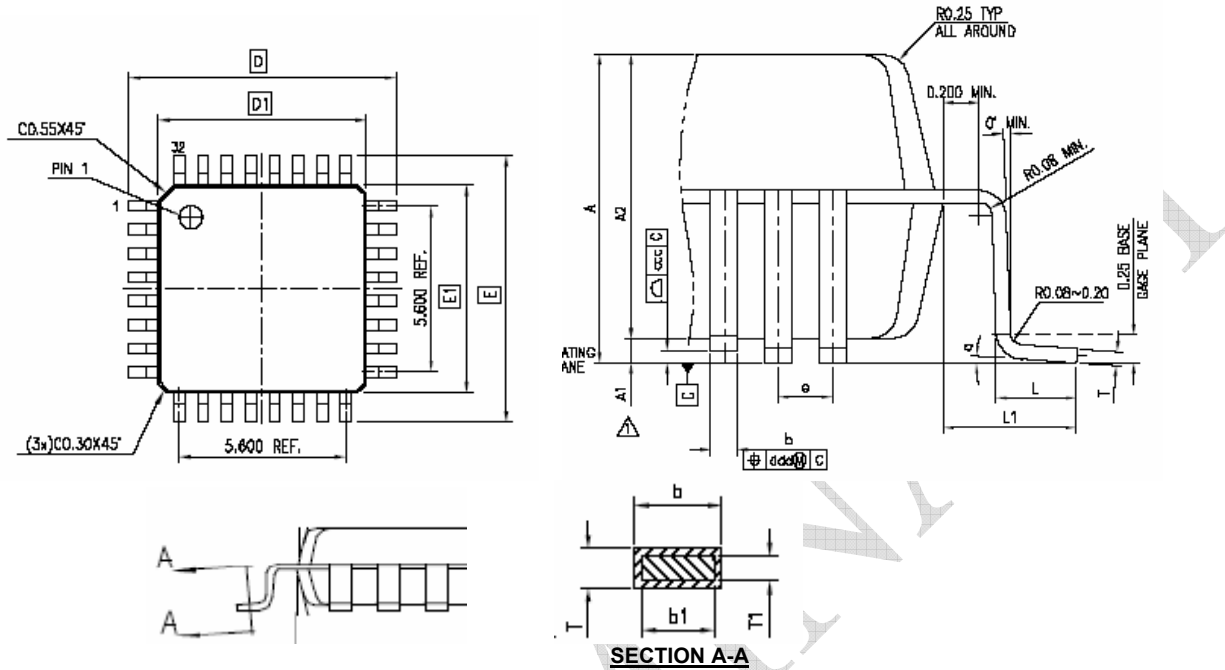

Symbol	Dimensions			
	Inches		Millimeters	
	Min	Max	Min	Max
A	0.0630	...	1.6
A1	0.0020	0.0059	0.05	0.15
A2	0.0531	0.0571	1.35	1.45
D	0.3465	0.3622	8.8	9.2
D1	0.2717	0.2795	6.9	7.1
E	0.3465	0.3622	8.8	9.2
E1	0.2717	0.2795	6.9	7.1
L	0.0177	0.0295	0.45	0.75
L1	0.03937 REF		1.00 REF	
T	0.0035	0.0079	0.09	0.2
T1	0.0038	0.0062	0.097	0.157
b	0.0118	0.0177	0.30	0.45
b1	0.0118	0.0157	0.30	0.40
R0	0.0031	0.0079	0.08	0.20
e	0.031 BPCSE		0.8 BPCSE	
a	0°	7°	0°	7°

32-lead TQFP

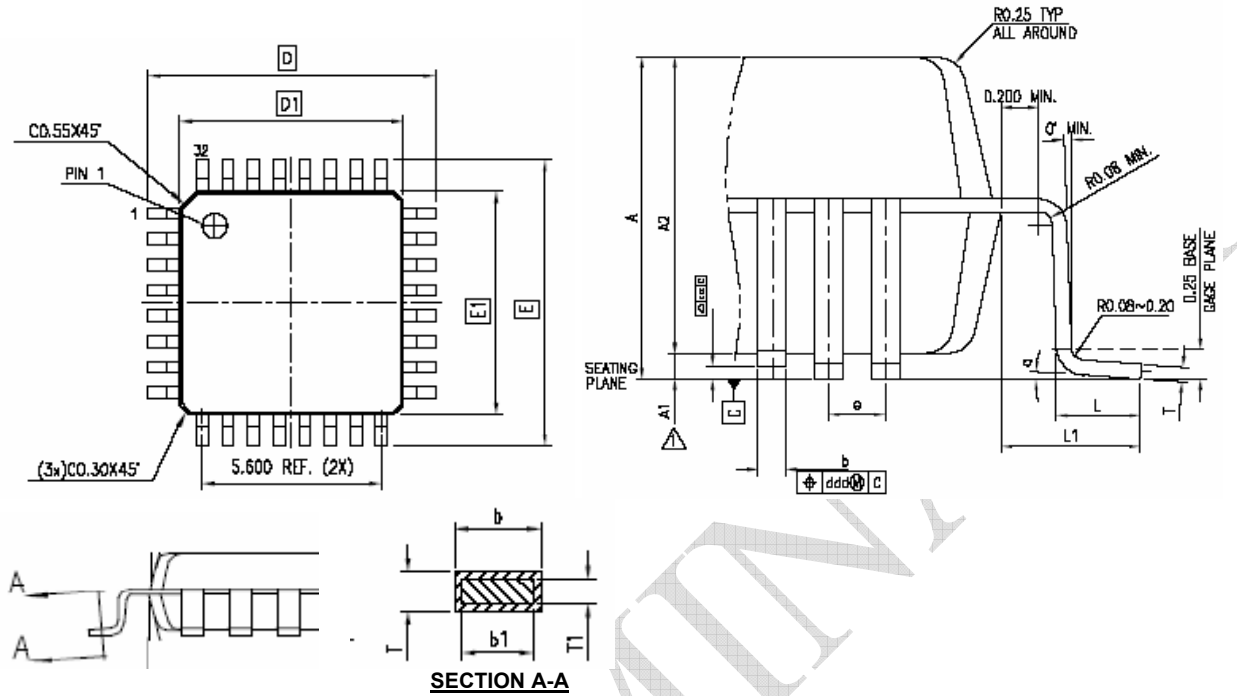

Symbol	Dimensions			
	Inches		Millimeters	
	Min	Max	Min	Max
A	0.0472	...	1.2
A1	0.0020	0.0059	0.05	0.15
A2	0.0374	0.0413	0.95	1.05
D	0.3465	0.3622	8.8	9.2
D1	0.2717	0.2795	6.9	7.1
E	0.3465	0.3622	8.8	9.2
E1	0.2717	0.2795	6.9	7.1
L	0.0177	0.0295	0.45	0.75
L1	0.03937 REF		1.00 REF	
T	0.0035	0.0079	0.09	0.2
T1	0.0038	0.0062	0.097	0.157
b	0.0118	0.0177	0.30	0.45
b1	0.0118	0.0157	0.30	0.40
RO	0.0031	0.0079	0.08	0.2
a	0°	7°	0°	7°
e	0.031 BPCSE		0.8 BPCSE	

rev 0.3

Ordering Information

Ordering Code	Top Mark	Package Type	Operating Range
PCS2P9942CG-32-LT	PCS2P9942CGL	32-pin LQFP, Tray, Green	Commercial
PCS2P9942CG-32-LR	PCS2P9942CGL	32-pin LQFP –Tape and Reel, Green	Commercial
PCS2P9942CG-32-ET	PCS2P9942CGE	32-pin TQFP, Tray, Green	Commercial
PCS2P9942CG-32-ER	PCS2P9942CGE	32-pin TQFP –Tape and Reel, Green	Commercial
PCS2I9942CG-32-LT	PCS2I9942CGL	32-pin LQFP, Tray, Green	Industrial
PCS2I9942CG-32-LR	PCS2I9942CGL	32-pin LQFP –Tape and Reel, Green	Industrial
PCS2I9942CG-32-ET	PCS2I9942CGE	32-pin TQFP, Tray, Green	Industrial
PCS2I9942CG-32-ER	PCS2I9942CGE	32-pin TQFP –Tape and Reel, Green	Industrial

Device Ordering Information

PCS2I9942CG-32-LR

R = Tape & Reel, T = Tube or Tray

Q = SOT	U = MSOP
S = SOIC	E = TQFP
T = TSSOP	L = LQFP
A = SSOP	U = MSOP
V = TVSOP	P = PDIP
B = BGA	D = QSOP
Q = QFN	X = SC-70

DEVICE PIN COUNT

G = GREEN PACKAGE, LEAD FREE, and RoHS

PART NUMBER

X= Automotive (-40C to +125C) I= Industrial (-40C to +85C) P or n/c = Commercial (0C to +70C)

1 = Reserved	6 = Power Management
2 = Non PLL bPcsed	7 = Power Management
3 = EMI Reduction	8 = Power Management
4 = DDR support products	9 = Hi Performance
5 = STD Zero Delav Buffer	0 = Reserved

PulseCore Semiconductor Mixed Signal Product

Licensed under US patent #5,488,627, #6,646,463 and #5,631,920.



PulseCore Semiconductor Corporation
1715 S. Bascom Ave Suite 200
Campbell, CA 95008
Tel: 408-879-9077
Fax: 408-879-9018
www.pulsecoresemi.com

Copyright © PulseCore Semiconductor
All Rights Reserved
Preliminary Information
Part Number: PCS2I9942C
Document Version: 0.3

Note: This product utilizes US Patent # 6,646,463 Impedance Emulator Patent issued to PulseCore Semiconductor, dated 11-11-2003

© Copyright 2006 PulseCore Semiconductor Corporation. All rights reserved. Our logo and name are trademarks or registered trademarks of PulseCore Semiconductor. All other brand and product names may be the trademarks of their respective companies. PulseCore reserves the right to make changes to this document and its products at any time without notice. PulseCore assumes no responsibility for any errors that may appear in this document. The data contained herein represents PulseCore's best data and/or estimates at the time of issuance. PulseCore reserves the right to change or correct this data at any time, without notice. If the product described herein is under development, significant changes to these specifications are possible. The information in this product data sheet is intended to be general descriptive information for potential customers and users, and is not intended to operate as, or provide, any guarantee or warranty to any user or customer. PulseCore does not assume any responsibility or liability arising out of the application or use of any product described herein, and disclaims any express or implied warranties related to the sale and/or use of PulseCore products including liability or warranties related to fitness for a particular purpose, merchantability, or infringement of any intellectual property rights, except as express agreed to in PulseCore's Terms and Conditions of Sale (which are available from PulseCore). All sales of PulseCore products are made exclusively according to PulseCore's Terms and Conditions of Sale. The purchase of products from PulseCore does not convey a license under any patent rights, copyrights; mask works rights, trademarks, or any other intellectual property rights of PulseCore or third parties. PulseCore does not authorize its products for use as critical components in life-supporting systems where a malfunction or failure may reasonably be expected to result in significant injury to the user, and the inclusion of PulseCore products in such life-supporting systems implies that the manufacturer assumes all risk of such use and agrees to indemnify PulseCore against all claims arising from such use.