



INTUITIVE HUMAN INTERFACE SOLUTIONS

6.5-inch VGA Display for Vehicles

- Ideal for gauges, diagnostic menus and other ancillary functions
- Capable of displaying three simultaneous video feeds
- J1939 compliant CAN interfaces
- Interface with Grayhill's 3J Series Vehicle Display Controller
- Sealed to IP67
- Optional touch screen
- 5 soft keys for menu selection
- Adjustable backlight on soft keys
- Die cast mount or RAM mount compatible
- Full color TFT
- LED backlight
- VGA resolution (640x480)
- 16 bit color
- Brightness 650 nits (measured)

ENVIRONMENTAL SPECIFICATIONS

Operating temperature	ANSI/ASEA EP455 5.1.1 Level 2	-30°C to +65°C
Storage Temperature	ANSI/ASEA EP455 5.1.2 Level 2	-40°C to +85°C
Thermal Shock	ANSI/ASEA EP455 5.1.3	-40°C to 70°C at a rate of 4°C/min (1 hour at extremes)
Altitude (Barometric Pressure)	ANSI/ASEA EP455 5.2	101.3kPa to 18.6kPa
Sand and Dust	ANSI/ASEA EP455 5.3	24 hours with 0.88g/m3
Solar Radiation	ANSI/ASEA EP455 5.4	43-75W/m2 UV Radiation (280-400nm wavelength) 300h
Ingress Protection / Rain	ANSI/ASEA EP455 5.6 Level 2	375 kPa and 8.3 L/min for 10 minutes @15°C water temp
Humidity	ANSI/ASEA EP455 5.13	96% humidity at 35°C for 240 hours
Salt Fog	ANSI/ASEA EP455 5.9	5% aqueous solution of NaCl @ 35°C and a pH between 6.5 and 7.2 for 48 hours
Chemical resistance	ISO 16750-5 EP 455 (5.8.2)	See Table 1
Thermal Cycling	ISO 16750-4	-40° to 85°C 2 hours at extremes change rate = 1°C/min (8 hours) repeat for 30 cycles.



EMBEDDED COMPUTER

- 416 MHz PXA270 processor
- 64MB SDRAM
- 128MB NAND program, and file system FLASH
- Windows CE or Linux Operating System
- Real time clock with 10 year battery backup

INPUT / OUTPUT

- 1 USB host port
- 3 CAN bus ports
- 3 NTSC/PAL video inputs
- 3 isolated serial ports
- 10/100 ethernet port
- Input voltage: 9VDC to 32VDC

CONNECTOR

- AMP 776164-1 mating connector
- AMP 770520-1 or AMP 770854-1 contacts

PART NUMBER | DESCRIPTION

3D65XK-1006	6.5 inch VGA Display, Windows CE6.0
3D65TK-1006	6.5 inch with touchscreen, WIN CE6.0

* Contact Grayhill for Linux version.

Your Experts in Cab Controls

Grayhill specializes in the design, development and production of human interface controls, including:

- Cab user interface design
- Customized control panels
- CAN-bus interface devices

www.grayhill.com

Agriculture



Construction





INTUITIVE HUMAN INTERFACE SOLUTIONS

DIMENSIONS

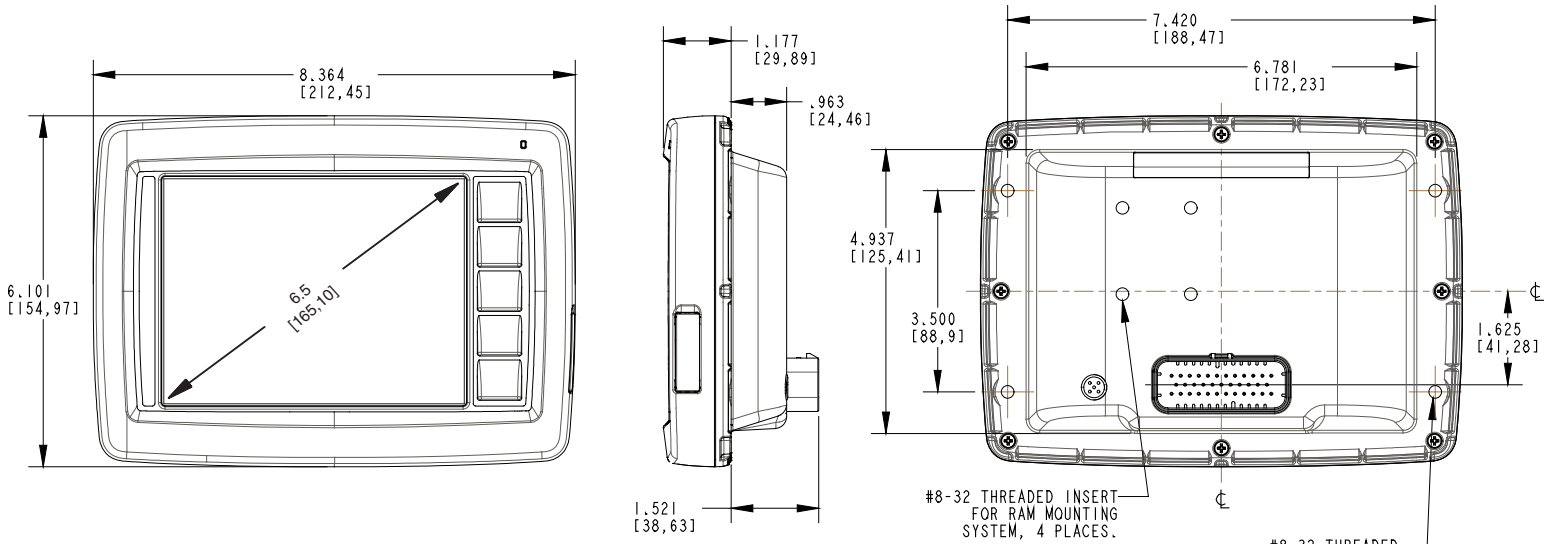

WEIGHT
2.2 lbs.

ELECTRICAL PERFORMANCE SPECIFICATIONS

Maximum Load	ANSI / ASAE EP455 Sec 5.1.1	T(min) = -40C, T(max) = +65C
Over-voltage	ANSI / ASAE EP455 Sec 5.10.2	Level 1, extended to 36V
Reverse Polarity	ANSI / ASAE EP455 Sec 5.10.3	extended to -36V
Short-circuit Protection	ANSI / ASAE EP455 Sec 5.10.4	extended to 36V
Starting Profile	ISO 16750-2 Sec. 4.6.3	12V, Code C / 24V Code E
Battery-less Operation	ANSI / ASAE EP455 Sec 5.11.3	Level 1
Load Dump	ISO 7637-2 Pulse 5b	Us = 174V, Ri = 2 Ohms, Td = 350mS, Us* = 70V
Switching Spikes	ISO 7637-2 Pulse 3a and 3b	Pulse 3a: Us = -200V, Pulse 3b: Us = 200V, 3000 reps
Wire Harness Induc-tance	ISO 7637-2 Pulse 2a	Us = 50V, t1 = 5s, 60 reps
Motor Shutdown Transients	ISO 7637-2 Pulse 2b	Us = 20V, t1 = 5s, Ri < .05 Ohms, 60 reps
Wire Harness Induc-tance Switching	ISO 7637-3 Pulse a and b	Pulse a: -80V, Pulse b: 80V, Class A, 6 min.
Inductive Load Switch-ing	ANSI / ASAE EP455 Sec 5.11.4	Level 1
Mutual Coupling (Power)	ANSI / ASAE EP455 Sec 5.11.6.1	Level 2
Mutual Coupling (Sig-nal/ Input)	ANSI / ASAE EP455 Sec 5.11.6.2	

MOUNTING INFO
Use M6 Nut (1mm pitch)
Max Torque 25 in-lbs

ELECTRICAL PERFORMANCE SPECIFICATIONS (CONTINUED)

Alternator Field Decay	ANSI / ASAE EP455 Sec 5.11.2	
ESD	ANSI / ASAE EP455 Sec 5.12	Level 2
Radiated Immunity	ANSI / ASAE EP455 Sec 5.16	Level 1
Broadband Radiated Emissions	ISO14982 Sec 6.4	
Narrowband Radiated Emissions	ISO 14982 Sec 6.5	
Conducted Emissions	SAE J1113-41	Class 2

MECHANICAL PERFORMANCE

Vibration, Random	ANSI/ASAE EP455 5.15.1	2h each axis @52.4m/s ² RMS overall accel-eration and spectral power density of 2m2/ s3 from 50Hz to 2000Hz
Vibration, Sinusoidal	ANSI/ASAE EP455 5.15.2	A logarithmic sweep from 10Hz to 2000Hz to 10Hz over a period of 20 minutes for 4 hours in each of 3 orthogonal axes with amplitude 1.5mm from 10Hz to 40Hz and a constant acceleration of 35m/s ² RMS from 40Hz to 2KHz
Shock / Crash Safety	ANSI/ASAE EP455 5.14	11ms half sine pulse of 490 m/s ² in 3 perpendicular axes
Drop	ANSI/ASAE EP455 5.14.2 Level 1	Drop component 400 mm onto a hardwood benchtop on all practical edges.

specifications subject to change

Grayhill, Inc.

561 Hillgrove Avenue
LaGrange, Illinois 60525

phone: (708) 354-1040
fax: (708) 354-2820

Bulletin 1129
Rev 10/12

www.grayhill.com

