

Digital Input Board with Opto-Isolation
for PCI Express

DI-128L-PE



* Specifications, color and design of the products are subject to change without notice.

Features

Optocoupler isolated inputs (compatible with current sink output)

This product has the 128 channels of Optocoupler isolated input (compatible with current sink output) whose response speed is 200μsec. Common terminal provided per 16 channels, capable of supporting a different external power supply. Supporting driver voltages of 12 - 24 VDC for I/O.

Optocoupler bus isolation

As the PC is isolated from the input and output interfaces by Optocoupler, this product has excellent noise performance.

You can use 16 input signals as interrupt request signals.

You can use 16 input signals as interrupt request signals and also disable or enable the interrupt in bit units and select the edge of the input signals, at which to generate an interrupt.

Windows/Linux compatible driver libraries are attached.

Using the attached driver library API-PAC(W32) makes it possible to create applications of Window/Linux. In addition, a diagnostic program by which the operations of hardware can be checked is provided.

This product has a digital filter to prevent wrong recognition of input signals from carrying noise or a chattering.

This product has a digital filter to prevent wrong recognition of input signals from carrying noise or a chattering. All input terminals can be added a digital filter, and the setting can be performed by software.

Functions and connectors are compatible with PCI compatible board PI-128L(PCI)H.

The functions same with PCI compatible board PI-128L(PCI)H are provided.

In addition, as there is compatibility in terms of connector shape and pin assignments, it is easy to migrate from the existing system.

LabVIEW is supported by a plug-in of dedicated library VI-DAQ.

Using the dedicated library VI-DAQ makes it possible to make a LabVIEW application.

This product is a PCI Express bus-compliant interface board used to provide a digital signal input function on a PC. This product can input digital signals at 12 - 24VDC.

This product features 128 Optocoupler isolated inputs. You can use 16 input signals as interrupt inputs. In addition, the digital filter function to prevent wrong recognition of input signals is provided.

Windows/Linux driver is bundled with this product. Possible to be used as a data recording device for LabVIEW, with dedicated libraries.

Specification

Item	Specification
Input	
Input format	Optocoupler isolated input (Compatible with current sink output)(Negative logic *1)
Number of input signal channels	128 channels (16 channels available for interrupts) (1 common per 16 channels unit)
Input resistance	4.7kΩ
Input ON current	2.0mA or more
Input OFF current	0.16mA or less
Interrupt	16 interrupt input signals are arranged into a single output of interrupt signal INTA. An interrupt is generated at the rising edge (HIGH-to-LOW transition) or falling edge (LOW-to-HIGH transition) (set by software).
Response time	Within 200μsec
Common	
Allowable distance of signal extension	Approx. 50m (depending on wiring environment)
I/O address	Any 32-byte boundary
Interruption level	1 level use
Max. board count for connection	16 boards including the master board
Isolated Power	250Vrms
External circuit power supply	12 - 24VDC(±10%)
Power consumption (Max.)	3.3VDC 600mA
Operating condition	0 - 50°C, 10 - 90%RH (No condensation)
Bus specification	PCI Express Base Specification Rev. 1.0a x1
Dimension (mm)	169.33(L) x 110.18(H)
Connector	100 pin 0.8mm pitch connector [F (female) type] x 2 HDRA-E100W1LFDT1EC-SL+[HONDA TSUSHIN KOGYO CO., LTD.] or equivalent to it
Weight	215g
Certification	RoHS,CE,VCCI

*1 Data "0" corresponds at the High level and data "1" correspond at the Low level.

Board Dimensions

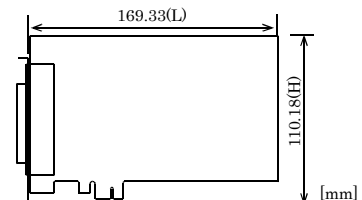

The standard outside dimension (L) is the distance from the end of the board to the outer surface of the slot cover.

Support Software

Windows version of digital I/O driver API-DIO(WDM) / API-DIO(98/PC)

[Stored on the bundled Disk driver library API-PAC(W32)]

The API-DIO(WDM) / API-DIO(98/PC) is the Windows version driver library software that provides products in the form of Win32 API functions (DLL). Various sample programs such as Visual Basic and Visual C++, etc and diagnostic program useful for checking operation is provided.

You can download the updated version from the CONTEC's Web site (<http://www.contec.com/apipac/>). For more details on the supported OS, applicable language and new information, please visit the CONTEC's Web site.

Linux version of digital I/O driver API-DIO(LNX)

[Stored on the bundled Disk driver library API-PAC(W32)]

The API-DIO(LNX) is the Linux version driver software which provides device drivers (modules) by shared library and kernel version. Various sample programs of gcc are provided.

You can download the updated version from the CONTEC's Web site (<http://www.contec.com/apipac/>). For more details on the supported OS, applicable language and new information, please visit the CONTEC's Web site.

Data acquisition VI library for LabVIEW VI-DAQ (Available for downloading (free of charge) from the CONTEC web site.)

This is a VI library to use in National Instruments LabVIEW. VI-DAQ is created with a function form similar to that of LabVIEW's Data Acquisition VI, allowing you to use various devices without complicated settings.

See <http://www.contec.com/vidaq/> for details and download of VI-DAQ.

Cable & Connector

Cable (Option)

Shielded Cable With Two 100pin Connector

- : PCB100PS-0.5 (0.5m)
- : PCB100PS-1.5 (1.5m)
- : PCB100PS-3 (3m)
- : PCB100PS-5 (5m)

Connection Conversion Shield Cable (100P→96P)

- : PCB100/96PS-1.5 (1.5m)
- : PCB100/96PS-3 (3m)
- : PCB100/96PS-5 (5m)

Flat Cable with One 100-Pin Connector

- : PCA100P-1.5 (1.5m)
- : PCA100P-3 (3m)
- : PCA100P-5 (5m)

Connection Conversion Shield Cable (100P→37P D-SUB x 2)

- : PCB100WS-1.5 (1.5m)
- : PCB100WS-3 (3m)
- : PCB100WS-5 (5m)

*1 If using both the CNA and CNB connectors, two cable sets are required.

Packing List

- Board [DI-128L-PE] ... 1
- First step guide ... 1
- Disk *1 [API-PAC(W32)] ... 1
- Serial number label... 1
- Product Registration Card & Warranty Certificate... 1

*1 The Disk contains the driver software and User's Guide.

Accessories

Accessories (Option)

Screw Terminal Unit (M3 x 100P)	: EPD-100A *1*4*6
Screw Terminal Unit (M3 x 96P)	: EPD-96A *2*4*6
Screw Terminal Unit (M3.5 x 96P)	: EPD-96 *2*4
Terminal Unit for Cables (M2.5 x 96P)	: DTP-64(PC) *2*4
Connector Conversion Board (96-Pin→37-Pin x 2)	: CCB-96 *2*4
Signal Monitor / Output Accessory for Digital I/O (64P)	: CM-64(PC)E *2*4
Screw Terminal Unit (M3 x 37P)	: EPD-37A *3*5*6
Screw Terminal Unit (M3.5 x 37P)	: EPD-37 *3*5
General Purpose Terminal (M3 x 37P)	: DTP-3A *3*5
Screw Terminal (M2.6 x 37P)	: DTP-4A *3*5

*1 PCB100PS optional cable is required separately.

*2 PCB100/96PS optional cable is required separately.

*3 PCB100WS optional cable is required separately.

*4 If using both the CNA and CNB connectors, two each of the terminal block and cable sets are required.

*5 If using both the CNA and CNB connectors, two cable sets are required.

You will also require sufficient terminal blocks for the number of I/O points you are using.

*6 "Spring-up" type terminal is used to prevent terminal screws from falling off.

* Check the CONTEC's Web site for more information on these options.

Block Diagram

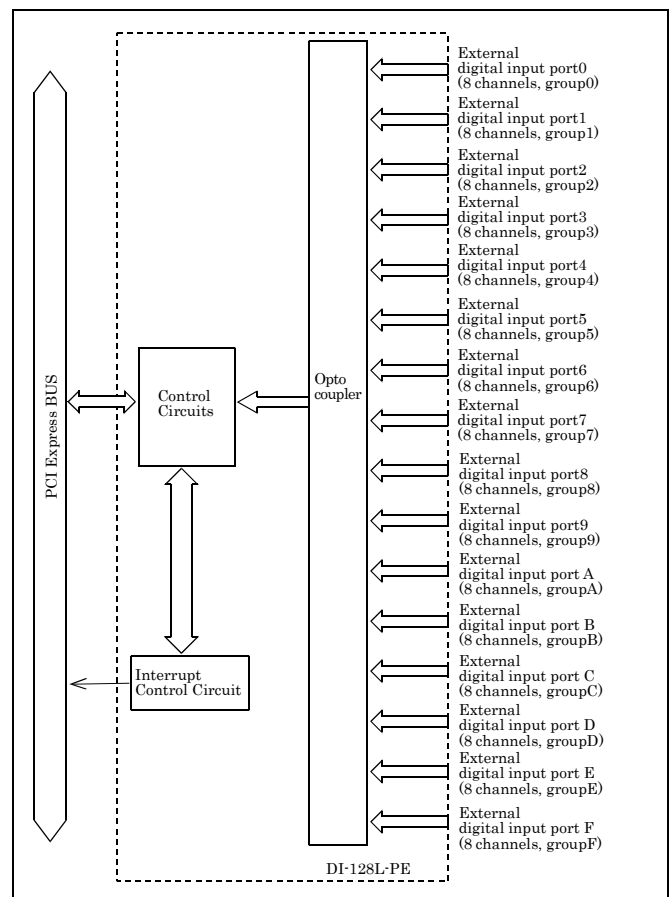

How to connect the connectors

Connector shape

The on-board interface connector (CNA, CNB) is used when connecting this product and the external devices.

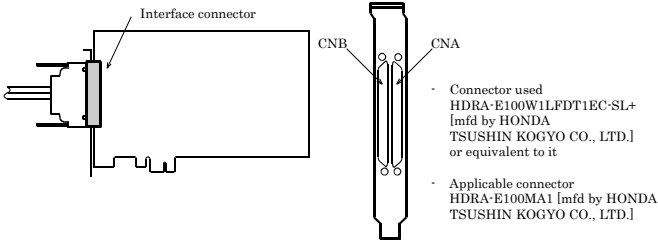

Connector used
HDRA-E100W1LFDT1EC-SL+
[mfd by HONDA
TSUSHIN KOGYO CO., LTD.]
or equivalent to it

Applicable connector
HDRA-E100MA1 [mfd by HONDA
TSUSHIN KOGYO CO., LTD.]

* Please refer to page 2 for more information on the supported cable and accessories.

Connector Pin Assignment

Pin Assignments Interface Connector (CNA, CNB)

Common plus pin for +E/+F input ports	P-E/F 100	50 P-A/B	Common plus pin for +A/+B input ports	N.C. 1	51 N.C.
I-F7 98		48 I-B7	+B port (Input)	N.C. 2	
I-F6 97		47 I-B6		N.C. 3	53 N.C.
I-F5 96		46 I-B5		N.C. 4	54 N.C.
I-F4 95		45 I-B4		N.C. 5	55 N.C.
I-F3 94		44 I-B3		N.C. 6	56 N.C.
I-F2 93		43 I-B2		*I-00 7	57 I-40
I-F1 92		42 I-B1		*I-01 8	58 I-41
I-F0 91		41 I-B0		*I-02 9	59 I-42
I-E7 90		40 I-A7	+A port (Input)	*I-03 10	60 I-43
I-E6 89		39 I-A6		*I-04 11	61 I-44
I-E5 88		38 I-A5		*I-05 12	62 I-45
I-E4 87		37 I-A4		*I-06 13	63 I-46
I-E3 86		36 I-A3		*I-07 14	64 I-47
I-E2 85		35 I-A2		*I-10 15	65 I-50
I-E1 84		34 I-A1		*I-11 16	66 I-51
I-E0 83		33 I-A0		*I-12 17	67 I-52
N.C. 82		32 N.C.		*I-13 18	68 I-53
N.C. 81		31 N.C.		*I-14 19	69 I-54
N.C. 80		30 N.C.		*I-15 20	70 I-55
N.C. 79		29 N.C.		*I-16 21	71 I-56
N.C. 78		28 N.C.		*I-17 22	72 I-57
N.C. 77		27 N.C.		P-0/1 24	73 P-4/5
N.C. 76		26 N.C.		N.C. 25	74 P-4/5
N.C. 75		25 N.C.		N.C. 26	75 N.C.
N.C. 74		24 P-8/9		N.C. 27	76 N.C.
N.C. 73		23 P-8/9		N.C. 28	77 N.C.
N.C. 72		22 I-97		N.C. 29	78 N.C.
N.C. 71		21 I-96		N.C. 30	79 N.C.
N.C. 70		20 I-95		N.C. 31	80 N.C.
N.C. 69		19 I-94		N.C. 32	81 N.C.
N.C. 68		18 I-93		I-20 33	82 N.C.
N.C. 67		17 I-92		I-21 34	83 I-60
N.C. 66		16 I-91		I-22 35	84 I-61
N.C. 65		15 I-90		I-23 36	85 I-62
N.C. 64		14 I-87		I-24 37	86 I-63
N.C. 63		13 I-86		I-25 38	87 I-64
N.C. 62		12 I-85		I-26 39	88 I-65
N.C. 61		11 I-84		I-27 40	89 I-66
N.C. 60		10 I-83		I-30 41	90 I-67
N.C. 59		9 I-82		I-31 42	91 I-70
N.C. 58		8 I-81		I-32 43	92 I-71
N.C. 57		7 I-80		I-33 44	93 I-72
N.C. 56		6 N.C.		I-34 45	94 I-73
N.C. 55		5 N.C.		I-35 46	95 I-74
N.C. 54		4 N.C.		I-36 47	96 I-75
N.C. 53		3 N.C.		I-37 48	97 I-76
N.C. 52		2 N.C.		I-37 48	98 I-77
N.C. 51		1 N.C.		P-2/3 49	99 P-6/7
				P-2/3 49	100 P-6/7

* I-00 - I-17 can be used as interrupt signal.

I-00 - I-F7	128 channels input signal. Connect output signals from the external device to these pins.
P-0/1 - P-E/F	Connect the positive side of the external power supply. These pins are common to 16 channels input signal.
N.C.	This pin is left unconnected.

Pin assignments for connecting to the PCB100/96PS or PCB100WS

PCB100/96PS

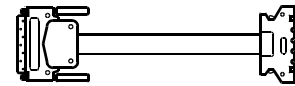

Unconnected	N.C. B01	A01 N.C.	Unconnected	Unconnected	N.C. B01	A01 N.C.	Unconnected
	N.C. B02	A02 N.C.			N.C. B02	A02 N.C.	
	I-CD B03	A03 I-B0			I-40 B03	A03 I-00	
	I-C1 B04	A04 I-B1			I-41 B04	A04 I-01	
	I-C2 B05	A05 I-B2			I-42 B05	A05 I-02	
	I-C3 B06	A06 I-B3			I-43 B06	A06 I-03	
	I-C4 B07	A07 I-B4			I-44 B07	A07 I-04	
	I-C5 B08	A08 I-B5			I-45 B08	A08 I-05	
	I-C6 B09	A09 I-B6			I-46 B09	A09 I-06	
	I-C7 B10	A10 I-B7			I-47 B10	A10 I-07	
	I-D0 B11	A11 I-90			I-50 B11	A11 I-10	
	I-D1 B12	A12 I-91			I-51 B12	A12 I-11	
	I-D2 B13	A13 I-92			I-52 B13	A13 I-12	
	I-D3 B14	A14 I-93			I-53 B14	A14 I-13	
	I-D4 B15	A15 I-94			I-54 B15	A15 I-14	
	I-D5 B16	A16 I-95			I-55 B16	A16 I-15	
	I-D6 B17	A17 I-96			I-56 B17	A17 I-16	
	I-D7 B18	A18 I-97			I-57 B18	A18 I-17	
	P-C/D B20	A20 P-8/9			P-4/5 B20	A20 P-0/1	
	N.C. B21	A21 N.C.			N.C. B21	A21 N.C.	
	N.C. B22	A22 N.C.			N.C. B22	A22 N.C.	
	N.C. B23	A23 N.C.			N.C. B23	A23 N.C.	
	N.C. B24	A24 N.C.			N.C. B24	A24 N.C.	
	N.C. B25	A25 N.C.			N.C. B25	A25 N.C.	
	N.C. B26	A26 N.C.			N.C. B26	A26 N.C.	
	N.C. B27	A27 N.C.			N.C. B27	A27 N.C.	
	N.C. B28	A28 N.C.			N.C. B28	A28 N.C.	
	N.C. B29	A29 N.C.			N.C. B29	A29 N.C.	
	N.C. B30	A30 N.C.			N.C. B30	A30 N.C.	
	I-E0 B31	A31 I-A0			I-B0 B31	A31 I-20	
	I-E1 B32	A32 I-A1			I-B1 B32	A32 I-21	
	I-E2 B33	A33 I-A2			I-B2 B33	A33 I-22	
	I-E3 B34	A34 I-A3			I-B3 B34	A34 I-23	
	I-E4 B35	A35 I-A4			I-B4 B35	A35 I-24	
	I-E5 B36	A36 I-A5			I-B5 B36	A36 I-25	
	I-E6 B37	A37 I-A6			I-B6 B37	A37 I-26	
	I-E7 B38	A38 I-A7			I-B7 B38	A38 I-27	
	I-F0 B39	A39 I-B0			I-70 B39	A39 I-30	
	I-F1 B40	A40 I-B1			I-71 B40	A40 I-31	
	I-F2 B41	A41 I-B2			I-72 B41	A41 I-32	
	I-F3 B42	A42 I-B3			I-73 B42	A42 I-33	
	I-F4 B43	A43 I-B4			I-74 B43	A43 I-34	
	I-F5 B44	A44 I-B5			I-75 B44	A44 I-35	
	I-F6 B45	A45 I-B6			I-76 B45	A45 I-36	
	I-F7 B46	A46 I-B7			I-77 B46	A46 I-37	
	P-E/F B48	A48 P-A/B			P-6/7 B47	A47 P-2/3	
					P-6/7 B48	A48 P-2/3	

* [] shows pin numbers specified by HONDA TSUSHIN KOGYO CO., LTD.

PCB100WS

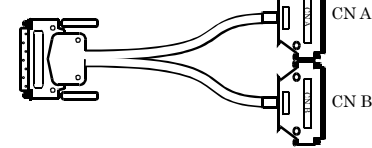

Common plus pin for +8/+9 input ports	P-8/9 18	37 P-A/B	Common plus pin for +A/+B input ports	Common plus pin for +0/+1 input ports	N.C. 19	37 P-2/3	Common plus pin for +2/+3 input ports
I-97 17		36 I-B7	+B port (Input)		I-17 17		36 I-37
I-96 16		35 I-B6			I-16 16		35 I-36
I-95 15		34 I-B5			I-15 15		34 I-35
I-94 14		33 I-B4			I-14 14		33 I-34
I-93 13		32 I-B3			I-13 13		32 I-33
I-92 12		31 I-B2			I-12 12		31 I-32
I-91 11		30 I-B1			I-11 11		30 I-31
I-90 10		29 I-B0			I-10 10		29 I-30
I-87 9		28 I-A7			I-07 9		28 I-27
I-86 8		27 I-A6			I-06 8		27 I-26
I-85 7		26 I-A5			I-05 7		26 I-25
I-84 6		25 I-A4			I-04 6		25 I-24
I-83 5		24 I-A3			I-03 5		24 I-23
I-82 4		23 I-A2			I-02 4		23 I-22
I-81 3		22 I-A1			I-01 3		22 I-21
I-80 2		21 I-A0			I-00 2		21 I-20
N.C. 1		20 N.C.			N.C. 1		20 N.C.

Common plus pin for +C/+D input ports	P-C/D 18	37 P-E/F	Common plus pin for +E/+F input ports	Common plus pin for +4/+5 input ports	N.C. 19	37 P-6/7	Common plus pin for +6/+7 input ports
I-D7 17		36 I-F7	+F port (Input)		I-57 17		36 I-77
I-D6 16		35 I-F6			I-56 16		35 I-76
I-D5 15		34 I-F5			I-55 15		34 I-75
I-D3 13		32 I-F3			I-54 14		32 I-74
I-D2 12		31 I-F2			I-52 12		31 I-72
I-D1 11		30 I-F1			I-51 11		30 I-71
I-D0 10		29 I-F0			I-50 10		29 I-70
I-C7 9		28 I-E7			I-47 9		28 I-67
I-C6 8		27 I-E6			I-46 8		27 I-66
I-C5 7		26 I-E5			I-45 7		26 I-65
I-C4 6		25 I-E4			I-44 6		25 I-64
I-C3 5		24 I-C3			I-43 5		24 I-63
I-C2 4		23 I-C2			I-42 4		23 I-62
I-C1 3		22 I-C1			I-41 3		22 I-61
I-C0 2		21 I-C0			I-40 2		21 I-60
N.C. 1		20 N.C.			N.C. 1		20 N.C.

Connecting Input signals

Connect the input signals to a device which can be current-driven, such as a switch or transistor output device. The connection requires an external power supply to feed currents.

The board inputs the ON/OFF state of the current-driven device as a digital value.

Input Circuit

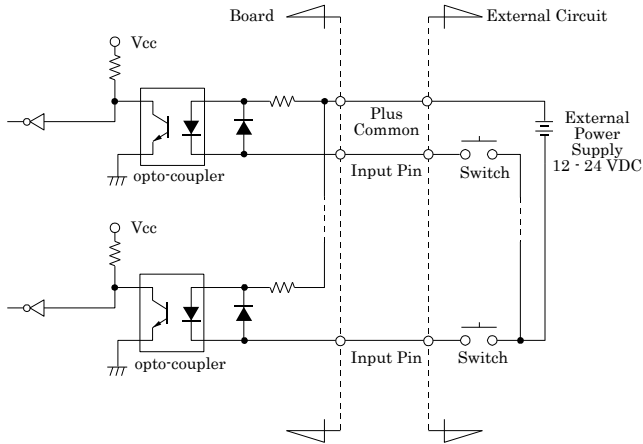

* I-xx shows input pins.

This product input circuit of interface is illustrated in the image above.

The signal inputs are isolated by Optocoupler (ready to accept current sinking output signals). The board therefore requires an external power supply to drive the inputs. The power requirement for each input pin is about 5.1mA at 24VDC (about 2.6mA at 12VDC).

Connecting to the Switch

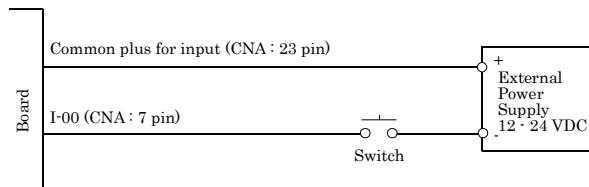

When the switch is ON, the corresponding bit contains 1.

When the switch is OFF, by contrast, the bit contains 0.

Connecting the Sink Type Output and Sink Output Support Input

The following example shows a connection between a sink type output (output board) and a sink output support input (input board). Refer to this connection example when you connect such boards to each other.

