

**FEATURES**

- 16/12-Bit Resolution and Monotonicity
- Dynamic Power Control for Thermal Management
- Voltage or Current Output on the Same Pin
- IOUT Range: 0mA-20mA, 4mA-20mA or 0mA-24mA
- ±0.05% Total Unadjusted Error (TUE) Max
- VOU Range: 0-5V, 0-10V, ±5V, ±10V, ±6V, ±12V
- ±0.05% Total Unadjusted Error (TUE) Max
- User programmable Offset and Gain
- On Chip Diagnostics
- On-Chip Reference (±5 ppm/°C)
- 40°C to +105°C Temperature Range

**APPLICATIONS**

- Process Control
- Actuator Control
- PLC's
- HART Network Connectivity

**PRODUCT HIGHLIGHTS**

- Dynamic Power Control for Thermal management
- 16bit performance
- Multi-channel
- HART Compliant

**GENERAL DESCRIPTION**

The AD5755-1 is a quad, voltage and current output DAC, which operates with a power supply range from -26v to +33v. On chip dynamic power control minimizes package power dissipation in current mode. This is achieved by regulating the voltage on the output driver from between 7V-30V.

Each channel has a corresponding CHART pin so that HART signals can be coupled onto the AD5755-1's current output.

The part uses a versatile 3-wire serial interface that operates at clock rates up to 30 MHz and that is compatible with standard SPI®, QSPI™, MICROWIRE™, DSP and microcontroller interface standards. The interface also features optional CRC-8 packet error checking as well as a watchdog timer that monitors activity on the interface.

Table 1. Complementary Devices

Part No.	Description
ADR445	5V, Ultralow Noise, LDO XFET Voltage Reference with Current Sink and Source
ADP1871	Synchronous Buck Controller with Constant On-Time, Valley Current Mode, and Power Save Mode

**FUNCTIONAL BLOCK DIAGRAM**

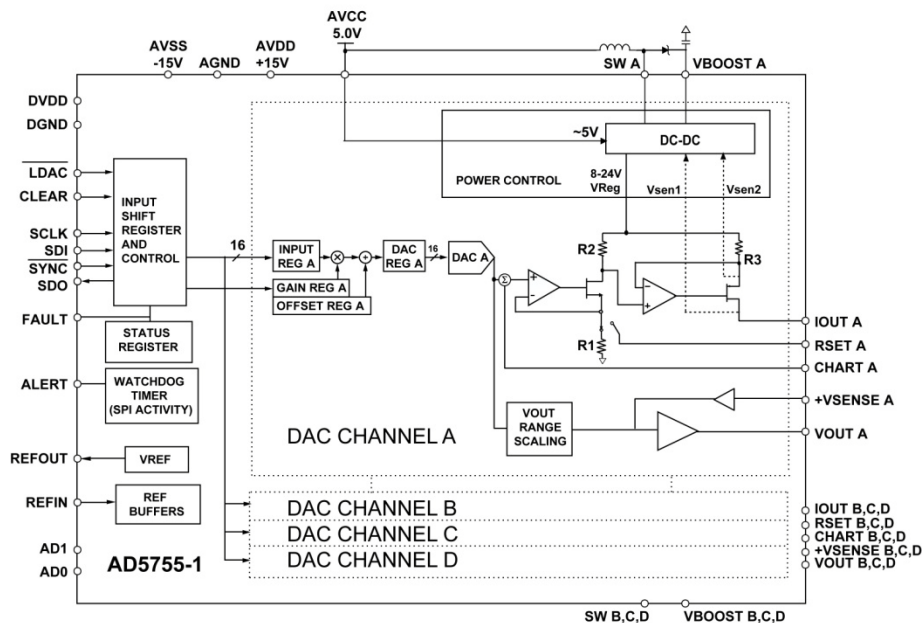

Figure 1.

Rev. PrD

Information furnished by Analog Devices is believed to be accurate and reliable. However, no responsibility is assumed by Analog Devices for its use, nor for any infringements of patents or other rights of third parties that may result from its use. Specifications subject to change without notice. No license is granted by implication or otherwise under any patent or patent rights of Analog Devices. Trademarks and registered trademarks are the property of their respective owners.

## TABLE OF CONTENTS

Features .....	1	Features .....	27
Applications.....	1	Output Fault.....	27
Product Highlights .....	1	Voltage Output Short Circuit Protection .....	27
General Description .....	1	Digital Offset and Gain Control.....	27
Revision History .....	2	Status Readback During Write .....	27
Specifications.....	3	Asynchronous Clear.....	28
AC Performance Characteristics .....	7	Packet Error Checking.....	28
Timing Characteristics .....	8	Watchdog timer .....	28
Absolute Maximum Ratings.....	11	Output Alert.....	28
ESD Caution.....	11	Internal Reference .....	28
Pin Configuration and Function Descriptions.....	12	External current setting resistor .....	28
Typical Performance Characteristics .....	15	HART .....	28
Theory of Operation .....	16	Slew rate control .....	29
DAC Architecture.....	16	Power Dissipation control.....	29
Power On State of AD5755-1.....	16	DC-DC Converters .....	29
Serial Interface .....	17	Applications Information .....	32
Transfer Function .....	17	Precision Voltage Reference Selection.....	32
Registers.....	18	Driving Inductive Loads.....	32
Programming Sequence to Write/Enable the Output		Transient voltage protection .....	32
Correctly.....	19	Microprocessor Interfacing.....	32
Changing and Reprogramming the Range .....	19	Layout Guidelines.....	32
Data Registers .....	20	Galvanically Isolated Interface .....	33
Control Registers.....	22	Outline Dimensions .....	34
Readback Operation .....	25	Ordering Guide .....	34

## SPECIFICATIONS

AVDD = 15V, AVSS = -15V/0V, V<sub>BOOSTA,B,C,D</sub> = +10.8 V to +33 V, DVDD = AVCC = 2.7 V to 5.5 V, DCDC disabled, AGND = DGND = GND<sub>SW A,B,C,D</sub> = 0 V, REFIN = +5, V<sub>OUT</sub> : R<sub>L</sub> = 1kΩ, C<sub>L</sub> = 220pF, I<sub>OUT</sub> : R<sub>L</sub> = 300Ω, all specifications T<sub>MIN</sub> to T<sub>MAX</sub> unless otherwise noted.

Table 2.

Parameter <sup>1</sup>	Min	Typ	Max	Unit	Test Conditions/Comments
<b>VOLTAGE OUTPUT</b>					
Output Voltage Ranges	0		5	V	
	0		10	V	AVDD needs to have min <b>TBDv</b> headroom on output.
	-5		+5	V	
	-10		+10	V	AVDD/AVSS need to have min <b>TBDv</b> headroom on output.
	0		6	V	
	0		12	V	AVDD needs to have min <b>TBDv</b> headroom on output.
	-6		+6	V	
	-12		+2	V	AVDD/AVSS need to have min <b>TBDv</b> headroom on output.
<b>ACCURACY</b>					
Resolution	16			Bits	
Total Unadjusted Error (TUE)	-0.04		+0.04	%FSR	
TUE TC <sup>2</sup>	-0.02	TBD	+0.02	%FSR	T <sub>A</sub> = 25°C
		±3		ppm FSR/°C typ	
Relative Accuracy (INL)	-0.006		+0.006	%FSR	
Differential Nonlinearity (DNL)	-1		+1	LSB	Guaranteed monotonic
Bipolar Zero Error	-TBD		+TBD	%FSR	
Bipolar Zero TC <sup>2</sup>	-0.008	TBD	+0.008	%FSR	T <sub>A</sub> = 25°C
		±3		ppm FSR/°C	
Zero-Scale Error	-TBD		+TBD	%FSR	
Zero-Scale TC <sup>2</sup>	-0.016	TBD	+0.016	%FSR	T <sub>A</sub> = 25°C
		±3		ppm FSR/°C	
Gain Error	-TBD		+TBD	%FSR	
Gain TC <sup>2</sup>	-TBD	TBD	+TBD	%FSR	T <sub>A</sub> = 25°C
				ppm FSR/°C	
Full-Scale Error	-TBD		+TBD	%FSR	T <sub>A</sub> = 25°C
Full-Scale TC <sup>2</sup>	-TBD	TBD	+TBD	%FSR	T <sub>A</sub> = 25°C
				ppm FSR/°C	
<b>OUTPUT CHARACTERISTICS<sup>2</sup></b>					
Headroom		1	TBD	V	
Output Voltage Drift vs. Time		±TBD		ppm FSR	Drift after 500 hours, T <sub>J</sub> = 150°C (this is included in the TUE specifications)
		±TBD		ppm FSR	Drift after 1000 hours, T <sub>J</sub> = 150°C (this is included in the TUE specifications)
Short-Circuit Current Load	1	15/8		mA	Programmable by user, defaults to 15ma Typ level.
Capacitive Load Stability				kΩ	For specified performance
	R <sub>L</sub> = ∞		20	nF	
	R <sub>L</sub> = 2 kΩ		TBD	nF	
	R <sub>L</sub> = ∞		2	μF	External compensation capacitor of min TBD pF connected.

Parameter <sup>1</sup>	Min	Typ	Max	Unit	Test Conditions/Comments
DC Output Impedance		0.3		Ω	
DC PSRR		TBD		μV/V	
			TBD	μV/V	
<b>CURRENT OUTPUT</b>					
Output Current Ranges	0		24	mA	
	0		20	mA	
	4		20	mA	
Resolution	16			Bits	
<b>ACCURACY (External R<sub>set</sub>)</b>					
Total Unadjusted Error (TUE)	-0.05		+0.05	% FSR	
	-0.02	TBD	+0.02	% FSR	T <sub>A</sub> = 25°C
TUE TC <sup>2</sup>	-TBD	±TB D	+TBD	ppm	
Relative Accuracy (INL)	-0.006		+0.006	% FSR	
Differential Nonlinearity (DNL)	-1		+1	LSB	Guaranteed monotonic
Offset Error	-0.035		+0.035	% FSR	
	-TBD	TBD	+TBD	% FSR	T <sub>A</sub> = 25°C
Offset Error Drift <sup>2</sup>		±TB D		ppm FSR/°C	
Gain Error	-0.02		+0.02	% FSR	
	-TBD	TBD	+TBD	% FSR	T <sub>A</sub> = 25°C
Gain TC <sup>2</sup>	-TBD		+TBD	ppm FSR/°C	
Full-Scale Error	-0.05		+0.05	% FSR	
	-TBD	TBD	+TBD	% FSR	T <sub>A</sub> = 25°C
Full-Scale TC <sup>2</sup>	-TBD		+TBD	ppm FSR/°C	
<b>ACCURACY (Internal R<sub>set</sub>)</b>					
Total Unadjusted Error (TUE)	-0.12		+0.12	% FSR	
	-0.02	TBD	+0.02	% FSR	T <sub>A</sub> = 25°C
TUE TC <sup>2</sup>	-TBD	±TB D	+TBD	ppm	
Relative Accuracy (INL)	-0.006		+0.006	% FSR	
Differential Nonlinearity (DNL)	-1		+1	LSB	Guaranteed monotonic
Offset Error	-0.04		+0.04	% FSR	
	-TBD	TBD	+TBD	% FSR	T <sub>A</sub> = 25°C
Offset Error Drift <sup>2</sup>		±TB D		ppm FSR/°C	
Gain Error	-0.08		+0.08	% FSR	
	-TBD	TBD	+TBD	% FSR	T <sub>A</sub> = 25°C
Gain TC <sup>2</sup>	-TBD		+TBD	ppm FSR/°C	
Full-Scale Error	-0.12		+0.12	% FSR	
	-TBD	TBD	+TBD	% FSR	T <sub>A</sub> = 25°C
Full-Scale TC <sup>2</sup>	-TBD		+TBD	ppm FSR/°C	
<b>OUTPUT CHARACTERISTICS<sup>2</sup></b>					
Current Loop Compliance Voltage		TBD	AVDD - 2.5	V max	
Output Current Drift vs. Time		±TB D		ppm FSR	Drift after 500 hours, T <sub>J</sub> = 150°C (this is included in the TUE specifications)
		±TB D		ppm FSR	Drift after 1000 hours, T <sub>J</sub> = 150°C (this is included in the TUE specifications)

Parameter <sup>1</sup>	Min	Typ	Max	Unit	Test Conditions/Comments
Resistive Load		See Comment		Ω max	Chosen such that compliance is not exceeded. Plus see graph on load vs AVcc and DCDC switching freq.
Inductive Load		See Comment		H max	Will need appropriate cap at higher inductance values. See Page X of Datasheet.
DC PSRR		TBD	TBD	μA/V μA/V	
Output Impedance		50		MΩ	
<b>REFERENCE INPUT/OUTPUT</b>					
Reference Input <sup>2</sup>					
Reference Input Voltage	4.95	5	5.05	V nom	For specified performance
DC Input Impedance	5	TBD		MΩ min	
Reference Output					
Output Voltage	4.998	5	5.002	V	T <sub>A</sub> = 25°C
Reference TC <sup>2,3</sup>	-10	±5	10	ppm/°C	
Output Noise (0.1 Hz to 10 Hz) <sup>2</sup>		TBD		μV p-p typ	
Noise Spectral Density <sup>2</sup>		TBD		nV/√Hz typ	At 10 kHz
Output Voltage Drift vs. Time <sup>2</sup>		±TBD		ppm	Drift after 500 hours, T <sub>J</sub> = 150°C
		±TBD		ppm	Drift after 1000 hours, T <sub>J</sub> = 150°C
Capacitive Load <sup>2</sup>			TBD	nF	
Load Current		5		mA	
Short Circuit Current		7		mA	
Line Regulation <sup>2</sup>		10		ppm/V	
Load Regulation <sup>2</sup>		TBD		ppm/mA	
Thermal Hysteresis <sup>2</sup>		TBD		ppm	
<b>DC-DC</b>					
<b>SWITCH</b>					
SWITCH On Resistance		0.5		ohm	
SWITCH Leakage Current		TBD		uA	VIN=TBD, IOUT=TBD, RLOAD=TBD
Peak Current Limit		0.8		A	
<b>OSCILLATOR</b>					
Oscillator Frequency	TBD	TBD	TBD	KHz	
Maximum Duty Cycle		TBD		%	
<b>DIGITAL INPUTS<sup>2</sup></b>					
V <sub>IH</sub> , Input High Voltage	2			V	JEDEC compliant
V <sub>IL</sub> , Input Low Voltage			0.8	V	
Input Current	-1		+1	μA	Per pin
Pin Capacitance		10		pF	Per pin
<b>DIGITAL OUTPUTS<sup>2</sup></b>					
<b>SDO, ALERT</b>					
V <sub>OL</sub> , Output Low Voltage			0.4	V	sinking 200 μA
V <sub>OH</sub> , Output High Voltage	DVDD -0.5			V	sourcing 200 μA
High Impedance Leakage Current	-1		+1	μA	
High Impedance Output Capacitance		5		pF	

Parameter <sup>1</sup>	Min	Typ	Max	Unit	Test Conditions/Comments
<b>FAULT</b>					
$V_{OL}$ , Output Low Voltage			0.4	V	10k $\Omega$ pull-up resistor to DVDD
$V_{OL}$ , Output Low Voltage		0.6		V	At 2.5 mA
$V_{OH}$ , Output High Voltage	3.6			V	10k $\Omega$ pull-up resistor to DVDD
<b>POWER REQUIREMENTS</b>					
$AV_{DD}$	12		33	V	Bipolar Supply Mode (In uni-polar supply mode tie $AV_{SS}$ to AGND)
$AV_{SS}$	-26.4		-10.8	V	
DVDD, AVCC					
Input Voltage	2.7		5.5	V	
$AI_{DD}$			TBD	mA	Output unloaded
$AI_{SS}$			TBD	mA	Bipolar Supply Mode only, outputs unloaded
$DI_{CC}$			TBD	mA	$V_{IH} = DVDD, V_{IL} = GND$
$AI_{CC}$			TBD	mA	DCDC 's not enabled
Power Dissipation		TBD		mW	$AV_{DD} = 33V, AV_{SS} = 0V$ , outputs unloaded
		TBD		mW	$AV_{DD} = 33V, AV_{SS} = -26.4V$ , outputs unloaded
		TBD		mW	$AV_{DD} = 15V, AV_{SS} = -15V$ , outputs unloaded

<sup>1</sup>Temperature range: -40°C to +105°C; typical at +25°C.

<sup>2</sup>Guaranteed by design and characterization; not production tested.

<sup>3</sup>The on-chip reference is production trimmed and tested at 25°C and 85°C. It is characterized from -40°C to +105°C.

**AC PERFORMANCE CHARACTERISTICS**

AVDD = 15V, AVSS = -15V/0V, V<sub>BOOSTA,B,C,D</sub> = +10.8 V to +33 V, DVDD = AVCC = 2.7 V to 5.5 V, DCDC disabled, AGND = DGND = GND, SW<sub>A,B,C,D</sub> = 0 V, REFIN = +5, V<sub>OUT</sub> : R<sub>L</sub> = 1kΩ, C<sub>L</sub> = 220pF, I<sub>OUT</sub> : R<sub>L</sub> = 300Ω, all specifications T<sub>MIN</sub> to T<sub>MAX</sub> unless otherwise noted.

Table 3.

Parameter <sup>1</sup>	Min	Typ	Max	Unit	Test Conditions/Comments
<b>DYNAMIC PERFORMANCE</b>					
<b>Voltage Output</b>					
Output Voltage Settling Time		TBD	TBD	μs typ	10 V step to ±0.03% FSR
		TBD	TBD	μs typ	100mv step to 1 LSB (16-Bit LSB)
Slew Rate		1		V/μs	
Power-On Glitch Energy		10		nV-sec	
Digital-to-Analog Glitch Energy		10		nV-sec	
Glitch Impulse Peak Amplitude		20		mV	
Digital Feedthrough		1		nV-sec	
DAC to DAC Crosstalk		TBD		nV-sec	
Output Noise (0.1 Hz to 10 Hz Bandwidth)		0.1		LSB p-p	(16-Bit LSB)
Output Noise (100 kHz Bandwidth)			TBD	μV rms	
Output Noise Spectral Density		TBD		nV/√Hz	Measured at 10 kHz
AC PSRR		TBD		dB	100mV 150KHz Sinewave superimposed on power supply voltage
AC PSRR		TBD		dB	200mV 50/60Hz Sinewave superimposed on power supply voltage
<b>Current Output</b>					
Output Current Settling Time		TBD	TBD	μs typ	To 0.1% FSR
		-		ms typ	See Figure 7 and Figure 8
Output Noise (0.1 Hz to 10 Hz Bandwidth)		0.1		LSB p-p	(16-Bit LSB)
Output Noise (100 kHz Bandwidth)			80	μV rms	
Output Noise Spectral Density		TBD		nV/√Hz	Measured at 10 kHz
Slew Rate		TBD		uA/μs	
		TBD		μs	To 0.1% FSR. See Figure 7 and Figure 8 for plots with a channels DC-DC enabled.

<sup>1</sup> Guaranteed by characterization, not production tested.

**TIMING CHARACTERISTICS**

AVDD = 15V, AVSS = -15V/0V, V<sub>BOOSTA,B,C,D</sub> = +10.8 V to +33 V, DVDD = AVCC = 2.7 V to 5.5 V, DCDC disabled, AGND = DGND = GND, SW<sub>A,B,C,D</sub> = 0 V, REFIN = +5, V<sub>OUT</sub> : R<sub>L</sub> = 1kΩ, C<sub>L</sub> = 220pF, I<sub>OUT</sub> : R<sub>L</sub> = 300Ω, all specifications T<sub>MIN</sub> to T<sub>MAX</sub> unless otherwise noted.

**Table 4.**

Parameter <sup>1, 2, 3</sup>	Limit at T <sub>MIN</sub> / T <sub>MAX</sub>	Unit	Description
t <sub>1</sub>	33	ns min	SCLK cycle time
t <sub>2</sub>	13	ns min	SCLK high time
t <sub>3</sub>	13	ns min	SCLK low time
t <sub>4</sub>	13	ns min	SYNC falling edge to SCLK falling edge setup time
t <sub>5</sub>	13	ns min	24/32nd SCLK falling edge to SYNC rising edge
t <sub>6</sub>	198	ns min	SYNC high time
t <sub>7</sub>	5	ns min	Data setup time
t <sub>8</sub>	5	ns min	Data hold time
t <sub>9</sub>	20	μs min	SYNC rising edge to LDAC falling edge (all DACs updated or any channel has digital slew rate control enabled)
	5	μs min	SYNC rising edge to LDAC falling edge (single DAC updated)
t <sub>10</sub>	10	ns min	LDAC pulse width low
t <sub>11</sub>	500	ns max	LDAC falling edge to DAC output response time
t <sub>12</sub>	See AC Performance Characteristics	μs max	DAC output settling time
t <sub>13</sub>	10	ns min	CLEAR high time
t <sub>14</sub>	TBD	μs max	CLEAR activation time
t <sub>15</sub>	25	ns max	SCLK rising edge to SDO valid (C <sub>L SDO</sub> = 35 pF)
t <sub>16</sub>	20	μs min	SYNC rising edge to DAC output response time (LDAC = 0) (all DACs updated)
	5	μs min	SYNC rising edge to DAC output response time (LDAC = 0) (single DAC updated)
t <sub>17</sub>	500	ns min	LDAC falling edge to SYNC rising edge
t <sub>18</sub>	700	ns min	RESET pulsewidth
t <sub>19</sub>	20	μs min	SYNC high to next SYNC low (Ramp enabled)
	5	μs min	SYNC high to next SYNC low (Ramp disabled)

<sup>1</sup> Guaranteed by design and characterization; not production tested.

<sup>2</sup> All input signals are specified with t<sub>r</sub> = t<sub>f</sub> = 5 ns (10% to 90% of DVDD) and timed from a voltage level of 1.2 V.

<sup>3</sup> See Figure 2, Figure 3, Figure 4 and Figure 5



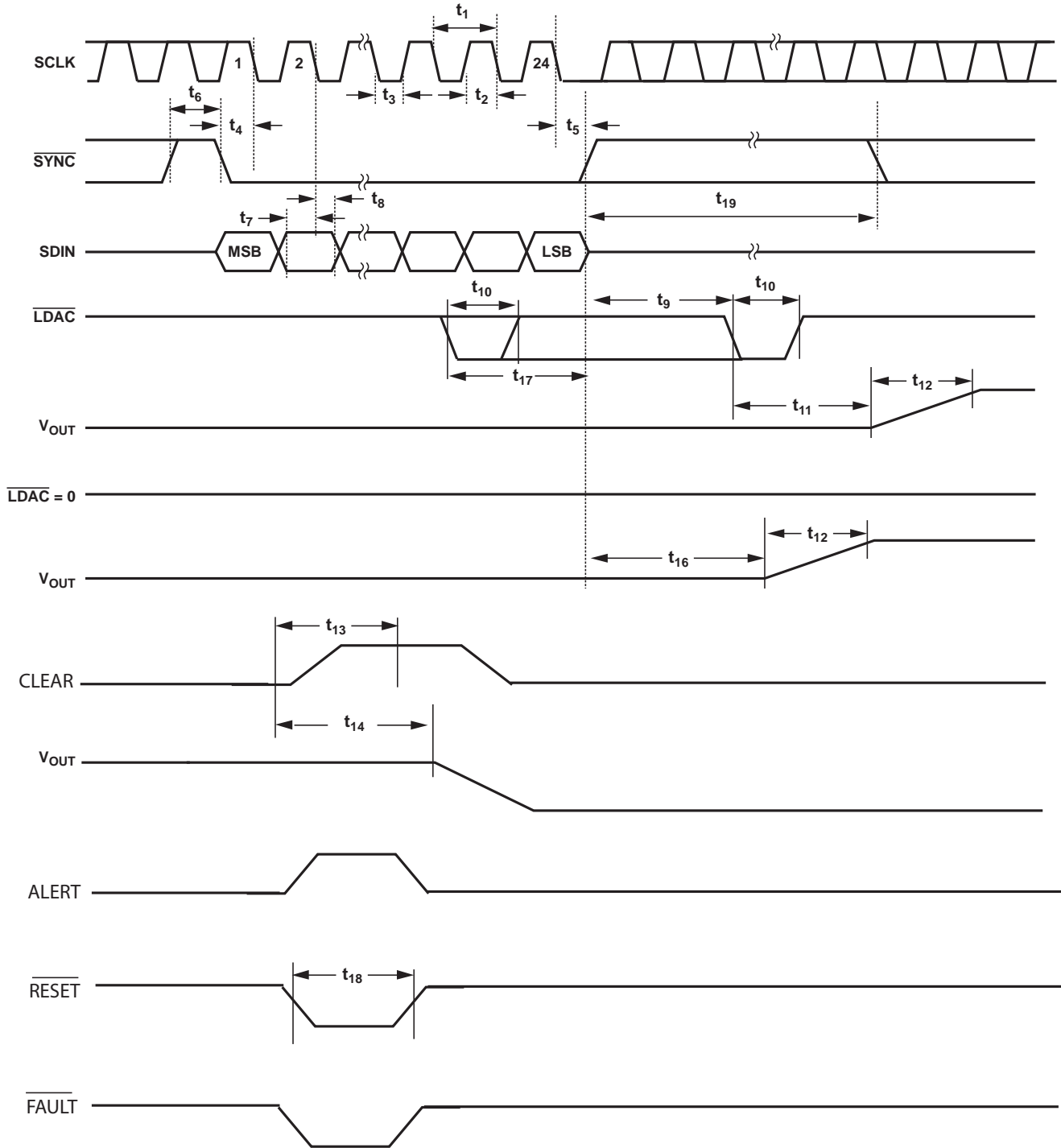

Figure 2. Serial Interface Timing Diagram

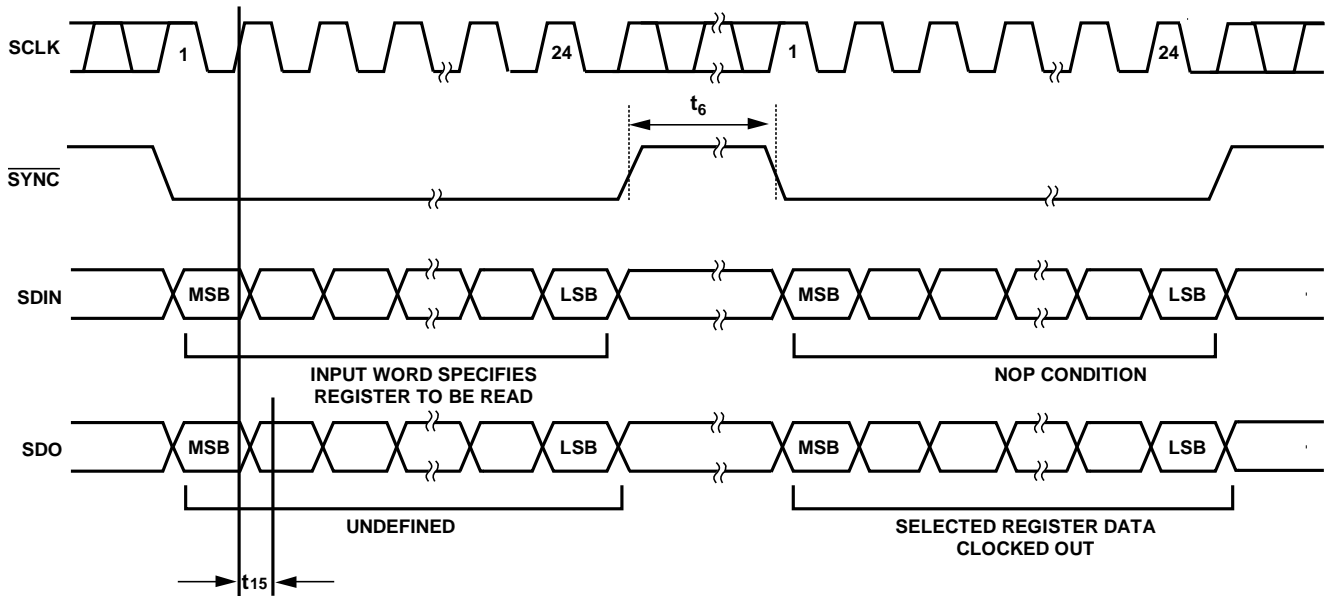
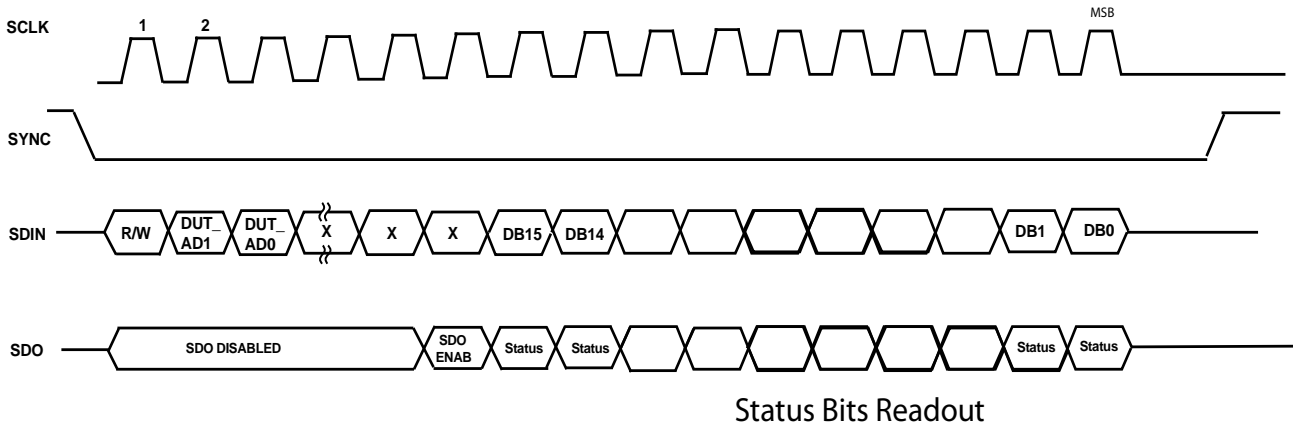

Figure 3. Readback Timing Diagram



Status Bits Readout

Figure 4. Status Readback during write

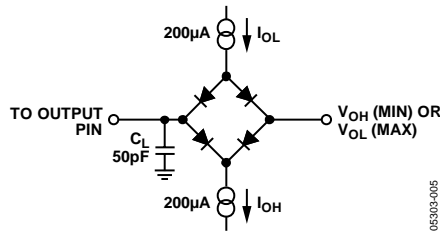

Figure 5. Load Circuit for SDO Timing Diagram

## ABSOLUTE MAXIMUM RATINGS

$T_A = 25^\circ\text{C}$ , unless otherwise noted. Transient currents of up to 100 mA do not cause SCR latch-up.

Table 5.

Parameter	Rating
$AV_{DD}$ to AGND, DGND	-0.3 V to +33 V
$AV_{SS}$ to AGND, DGND	+0.3 V to -28 V
$AV_{DD}$ to $AV_{SS}$	-0.3 V to +60 V
$AV_{CC}$ to AGND	-0.3 V to +7 V
DVDD to DGND	-0.3 V to +7 V
Digital Inputs to DGND	-0.3 V to DVDD + 0.3 V or +7 V (whichever is less)
Digital Outputs to DGND	-0.3 V to DVDD + 0.3 V
REFIN/REFOUT to AGND	-0.3 V to $AV_{DD} + 0.3$ V or 7 V (whichever is less)
VOUTA, VOUTB, VOUTC, VOUTD to AGND	$AV_{SS}$ to $AV_{DD}$
$+V_{SENSE\ A,B,C,D}$ to AGND	$AV_{SS}$ to $AD_{DD}$
$COMP_{LVA,B,C,D}$ to AGND	0.3 V to +5 V
$I_{OUT\ A,B,C,D}$ to AGND	-0.3 V to $AV_{DD}$
$R_{SETA,B,C,D}$ to AGND	-0.3 V to $AV_{DD} + 0.3$ V or +7 V (whichever is less)
$SW_{A,B,C,D} / V_{BOOSTA,B,C,D}$ to AGND	-0.3 to +33 V
$COMP_{DCDC\ A,B,C,D} / CHART_{A,B,C,D}$ to AGND	-0.3 V to +5 V
AGND, $GND_{SW\ A,B,C,D}$ to DGND	-0.3 V to +0.3 V
Operating Temperature Range ( $T_A$ )	
Industrial <sup>1</sup>	-40°C to +105°C
Storage Temperature Range	-65°C to +150°C
Junction Temperature ( $T_J$ max)	125°C
64-Lead LFCSP	
$\theta_{JA}$ Thermal Impedance <sup>2</sup>	20°C/W
Power Dissipation	$(T_J\ max - T_A) / \theta_{JA}$
Lead Temperature	JEDEC Industry Standard
Soldering	J-STD-020

<sup>1</sup> Power dissipated on chip must be derated to keep the junction temperature below 125°C

<sup>2</sup> Based on a JEDEC 4 layer test board

Stresses above those listed under Absolute Maximum Ratings may cause permanent damage to the device. This is a stress rating only; functional operation of the device at these or any other conditions above those indicated in the operational section of this specification is not implied. Exposure to absolute maximum rating conditions for extended periods may affect device reliability.

### ESD CAUTION



**ESD (electrostatic discharge) sensitive device.** Charged devices and circuit boards can discharge without detection. Although this product features patented or proprietary protection circuitry, damage may occur on devices subjected to high energy ESD. Therefore, proper ESD precautions should be taken to avoid performance degradation or loss of functionality.

## PIN CONFIGURATION AND FUNCTION DESCRIPTIONS

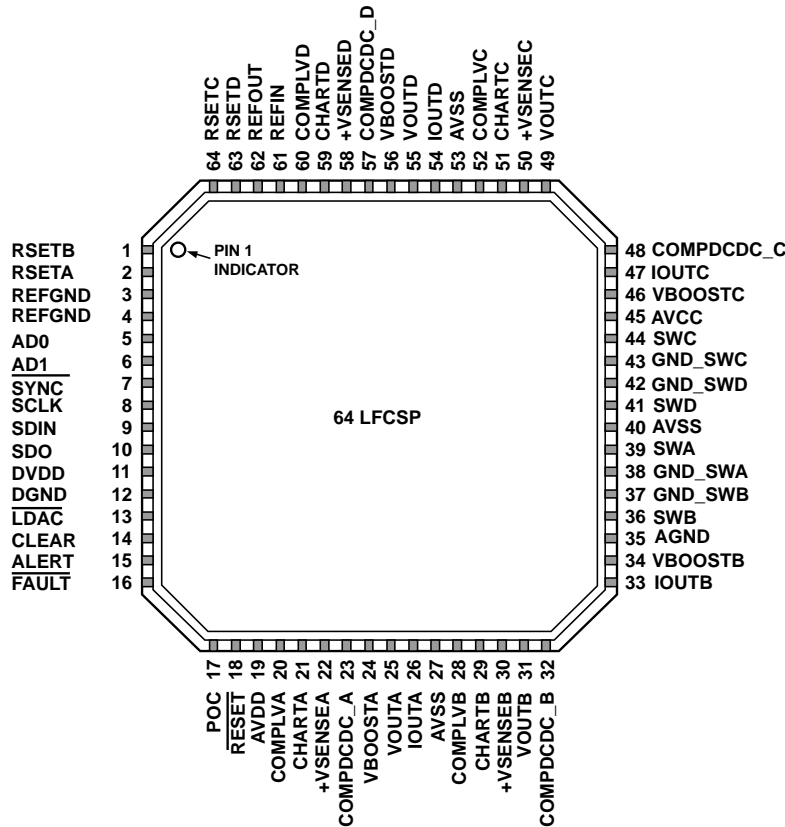

Figure 6. 64 LFCSP Pin Configuration

Table 6. Pin Function Descriptions

Pin No.	Mnemonic	Description
1	R <sub>SET_B</sub>	An external, precision, low drift 15 kΩ current setting resistor can be connected to this pin to improve the I <sub>OUT_B</sub> temperature drift performance. See the Features section.
2	R <sub>SET_A</sub>	An external, precision, low drift 15 kΩ current setting resistor can be connected to this pin to improve the I <sub>OUT_A</sub> temperature drift performance. See the Features section.
3	REFGND	Ground Reference Point for Internal Reference.
4	REFGND	Ground Reference Point for Internal Reference.
5	AD0	Address decode for the DUT on the board.
6	AD1	Address decode for the DUT on the board.
7	SYNC	Active Low Input. This is the frame synchronization signal for the serial interface. While SYNC is low, data is transferred in on the falling edge of SCLK.
8	SCLK	Serial Clock Input. Data is clocked into the shift register on the rising edge of SCLK. This operates at clock speeds of up to 30 MHz.
9	SDIN	Serial Data Input. Data must be valid on the falling edge of SCLK.
10	SDO	Serial Data Output. Used to clock data from the serial register in readback mode. See Figure 3 and Figure 4.
11	DV <sub>DD</sub>	Digital Supply Pin. Voltage ranges from 2.7 V to 5.5 V.
12	DGND	Digital Ground Pin.
13	LDAC	Load DAC. Active Low Input. This is used to update the DAC registers and consequently the analog outputs. When tied permanently low the addressed DAC register is updated on the rising edge of SYNC. If LDAC is held high during the write cycle the DAC input register is updated but the output update only takes place at the falling edge of LDAC. See Figure 2. Using this mode all analog outputs can be updated simultaneously. The LDAC pin must not be left unconnected.
14	CLEAR	Active High, Edge Sensitive Input. Asserting this pin sets the Output Current/Voltage to the pre-programmed CLEAR CODE. Only channels enabled to be cleared will be cleared. See features section for

Pin No.	Mnemonic	Description
15	ALERT	more information. When CLEAR is active, the DAC register cannot be written to.
16	FAULT	Active High Output. This pin is asserted when there has been no SPI activity on the interface pins for a predetermined time. See features section for more information.
17	POC	Active Low Output. This pin is asserted low when an open circuit in current mode is detected or a short circuit in voltage mode is detected or a PEC error is detected or an over temperature is detected (see Features section). Open Drain Output.
18	RESET	Power- On Condition. This pin determines the Power on Condition. If POC='0', the device is powered up with the voltage and current channels in Tri-State mode. If POC='1', the device is powered up with a 30k $\Omega$ pull down resistor to GND on the voltage output channel, and the current channels in Tri-State mode.
19	AV <sub>DD</sub>	Hardware Reset. Active Low Input.
20	COMP <sub>LV_A</sub>	Positive Analog Supply Pin. Voltage ranges from 10.8 V to 33 V.
21	CHARTA	Optional compensation capacitor connection for V <sub>OUT_A</sub> 's output buffer. Connecting a 220 pF capacitor between this pin and the V <sub>OUT_A</sub> pin allows the voltage output to drive up to 1 $\mu$ F. It should be noted that the addition of this capacitor reduces the bandwidth of the output amplifier, increasing the settling time.
22	+V <sub>SENSE_A</sub>	Hart Input Connection for DAC Channel A
23	COMP <sub>DCDC_A</sub>	Sense connection for the positive voltage output load connection for V <sub>OUT_A</sub> . This pin must stay within $\pm 3.0$ V of V <sub>OUT_A</sub> for correct operation.
24	V <sub>BOOST_A</sub>	DC-DC Compensation Capacitor. Connect a 10 nF capacitor from this pin to ground. Used to regulate the feedback loop of channel A's DC-DC converter.
25	V <sub>OUT_A</sub>	Supply for channel A's current output stage (See Figure 15). To use the DC-DC feature of the device, connect as shown in Figure 21.
26	I <sub>OUT_A</sub>	Buffered Analog Output Voltage for DAC Channel A.
27	AV <sub>SS</sub>	Current Output Pin for DAC Channel A.
28	COMP <sub>LV_B</sub>	Negative Analog Supply Pin. Voltage ranges from -10.8 V to -26.4 V. This pin can be connected to 0 V if the output voltage range is unipolar,.
29	CHARTB	Optional compensation capacitor connection for V <sub>OUT_B</sub> 's output buffer. Connecting a 220 pF capacitor between this pin and the V <sub>OUT_B</sub> pin allows the voltage output to drive up to 1 $\mu$ F. It should be noted that the addition of this capacitor reduces the bandwidth of the output amplifier, increasing the settling time.
30	+V <sub>SENSE_B</sub>	Hart Input Connection for DAC Channel B
31	V <sub>OUT_B</sub>	Sense connection for the positive voltage output load connection for V <sub>OUT_B</sub> . This pin must stay within $\pm 3.0$ V of V <sub>OUT_B</sub> for correct operation.
32	COMP <sub>DCDC_B</sub>	Buffered Analog Output Voltage for DAC Channel B.
33	I <sub>OUT_B</sub>	DC-DC Compensation Capacitor. Connect a 10 nF capacitor from this pin to ground. Used to regulate the feedback loop of channel B's DC-DC converter.
34	V <sub>BOOST_B</sub>	Current Output Pin for DAC Channel B.
35	AGND	Supply for channel B's current output stage (See Figure 15). To use the DC-DC feature of the device, connect as shown in Figure 21.
36	SW <sub>B</sub>	Ground Reference Point for Analog Circuitry. This must be connected to 0 V.
37	GND <sub>SW_B</sub>	Switching output for Channel B's DC-DC circuitry. To use the DC-DC feature of the device, connect as shown in Figure 21.
38	GND <sub>SW_A</sub>	Ground connection for DC-DC switching circuit. This pin should always be connected to GND.
39	SW <sub>A</sub>	Ground connection for DC-DC switching circuit. This pin should always be connected to GND.
40	AV <sub>SS</sub>	Switching output for Channel A's DC-DC circuitry. To use the DC-DC feature of the device, connect as shown in Figure 21.
41	SW <sub>D</sub>	Negative Analog Supply Pin. Voltage ranges from -10.8 V to -26.4 V.
42	GND <sub>SW_D</sub>	Switching output for Channel D's DC-DC circuitry. To use the DC-DC feature of the device, connect as shown in Figure 21.
43	GND <sub>SW_C</sub>	Ground connections for DC-DC switching circuit. This pin should always be connected to GND.
44	SW <sub>C</sub>	Ground connections for DC-DC switching circuit. This pin should always be connected to GND.
45	AV <sub>CC</sub>	Switching output for Channel C's DC-DC circuitry. To use the DC-DC feature of the device, connect as shown in Figure 21.
46	V <sub>BOOST_C</sub>	Supply for DC-DC circuitry.
		Supply for channel C's current output stage (See Figure 15). To use the DC-DC feature of the device, connect as shown in Figure 21.

Pin No.	Mnemonic	Description
47	$I_{OUT\_C}$	Current Output Pin for DAC Channel C.
48	COMP <sub>DCDC_C</sub>	DC-DC Compensation Capacitor. Connect a 10 nF capacitor from this pin to ground. Used to regulate the feedback loop of channel C's DC-DC converter.
49	$V_{OUT\_C}$	Buffered Analog Output Voltage for DAC Channel C.
50	+ $V_{SENSE\_C}$	Sense connection for the positive voltage output load connection for $V_{OUT\_C}$ . This pin must stay within $\pm 3.0$ V of $V_{OUT\_C}$ for correct operation.
51	CHARTC	Hart Input Connection for DAC Channel C
52	COMP <sub>LV_C</sub>	Optional compensation capacitor connection for $V_{OUT\_C}$ 's output buffer. Connecting a 220 pF capacitor between this pin and the $V_{OUT\_C}$ pin allows the voltage output to drive up to 1 $\mu$ F. It should be noted that the addition of this capacitor reduces the bandwidth of the output amplifier, increasing the settling time.
53	AV <sub>SS</sub>	Negative Analog Supply Pin.
54	$I_{OUT\_D}$	Current Output Pin for DAC Channel D.
55	$V_{OUT\_D}$	Buffered Analog Output Voltage for DAC Channel D.
56	$V_{BOOST\_D}$	Supply for channel D's current output stage (See Figure 15). To use the DC-DC feature of the device, connect as shown in Figure 21.
57	COMP <sub>DCDC_D</sub>	DC-DC Compensation Capacitor. Connect a 10 nF capacitor from this pin to ground. Used to regulate the feedback loop of channel D's DC-DC converter.
58	+ $V_{SENSE\_D}$	Sense connection for the positive voltage output load connection for $V_{OUT\_D}$ . This pin must stay within $\pm 3.0$ V of $V_{OUT\_D}$ for correct operation.
59	CHARTD	Hart Input Connection for DAC Channel D
60	COMP <sub>LV_D</sub>	Optional compensation capacitor connection for $V_{OUT\_D}$ 's output buffer. Connecting a 220 pF capacitor between this pin and the $V_{OUT\_D}$ pin allows the voltage output to drive up to 1 $\mu$ F. It should be noted that the addition of this capacitor reduces the bandwidth of the output amplifier, increasing the settling time.
61	REFIN	External Reference Voltage Input.
62	REFOUT	Internal Reference Voltage Output.
63	$R_{SET\_D}$	An external, precision, low drift 15 k $\Omega$ current setting resistor can be connected to this pin to improve the $I_{OUT\_D}$ temperature drift performance. See the Features section.
64	$R_{SET\_C}$	An external, precision, low drift 15 k $\Omega$ current setting resistor can be connected to this pin to improve the $I_{OUT\_C}$ temperature drift performance. See the Features section.
	Exposed PADDLE	CONNECTED TO AV <sub>SS</sub>

### TYPICAL PERFORMANCE CHARACTERISTICS

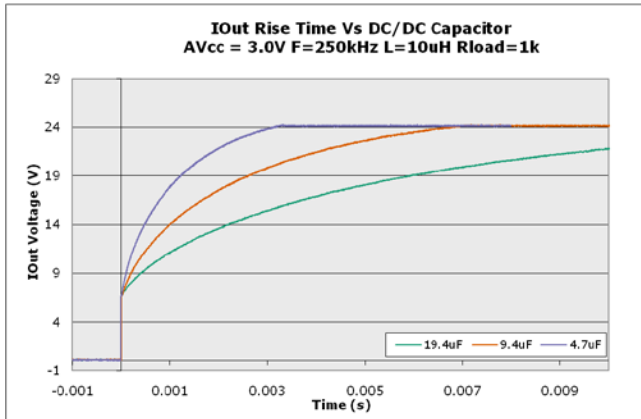

Figure 7. Iout settling 0-24mA though 1kΩ load, AV<sub>cc</sub>=3.0V, L<sub>DCDC</sub>=10uH, DCDC frequency=250kHz, C<sub>DCDC</sub> varied. (See Figure 21)

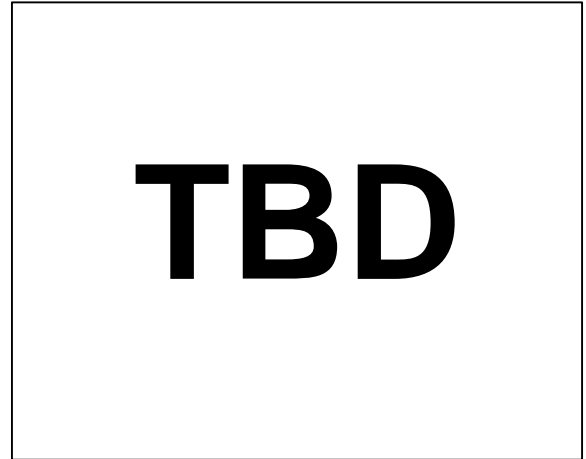

Figure 10.

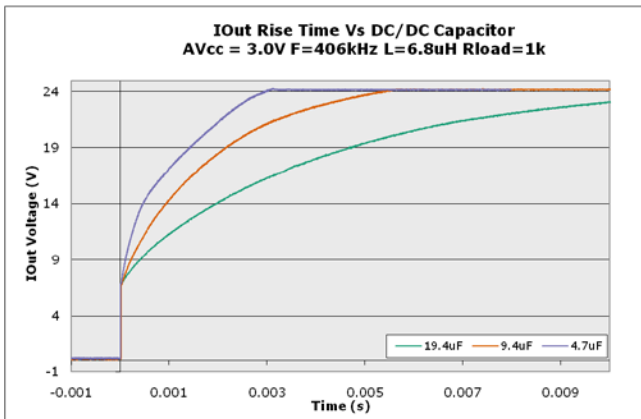

Figure 8. Iout settling 0-24mA though 1kΩ load, AV<sub>cc</sub>=3.0V, L<sub>DCDC</sub>=10uH, DCDC frequency=406kHz, C<sub>DCDC</sub> varied. (See Figure 21)

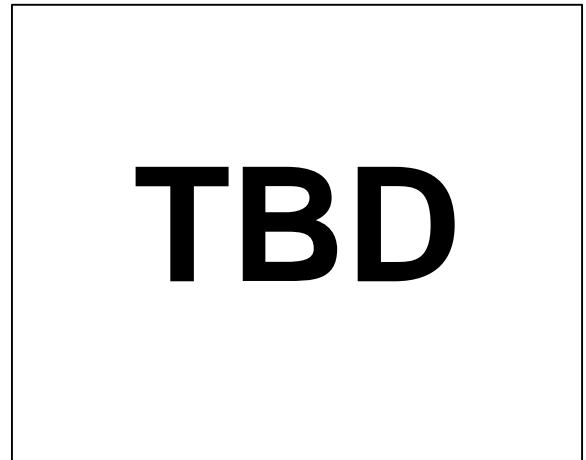

Figure 11.

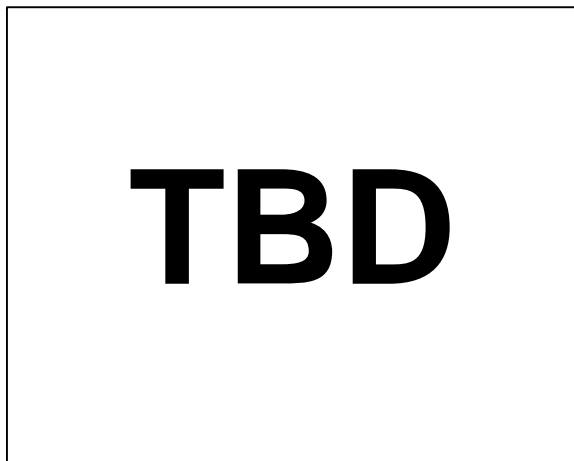

Figure 9

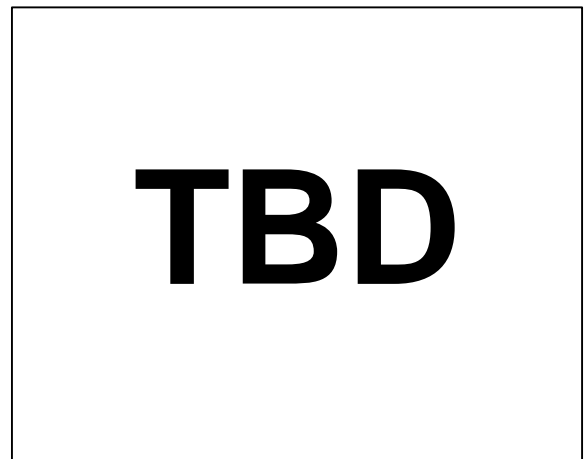

Figure 12

## THEORY OF OPERATION

The AD5755-1 is a quad, precision digital to current loop and voltage output converter designed to meet the requirements of industrial process control applications. It provides a high precision, fully integrated, low cost single-chip solution for generating current loop and unipolar/bipolar voltage outputs. The current ranges available are; 0 to 20mA, 0 to 24mA and 4 to 20mA, the voltage ranges available are; 0 to 5V,  $\pm 5V$ , 0 to 10V and  $\pm 10V$ , the current and voltage outputs are available on separate pins and only one is active at any one time. The desired output configuration is user selectable via the DAC Control Register.

On chip dynamic power control minimizes package power dissipation in current mode.

### DAC ARCHITECTURE

The DAC core architecture of the AD5755-1 consists of two matched DAC sections. A simplified circuit diagram is shown in Figure 13. The 4 MSBs of the 16/12-bit data word are decoded to drive 15 switches, E1 to E15. Each of these switches connects 1 of 15 matched resistors to either ground or the reference buffer output. The remaining 12/8 bits of the data-word drive switches S0 to S11 /S7 of a 12/8-bit voltage mode R-2R ladder network.

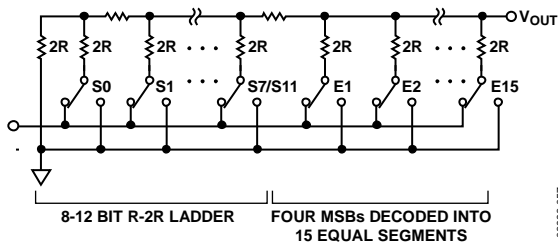

Figure 13. DAC Ladder Structure

The voltage output from the DAC core is either converted to a current (see Figure 15) which is then mirrored to the supply rail so that the application simply sees a current source output with respect to ground or it is buffered and scaled to output a software selectable unipolar or bipolar voltage range (See diagram, Figure 14). The current and voltage are output on separate pins and cannot be output simultaneously. A channels current and voltage output pins may be tied together.

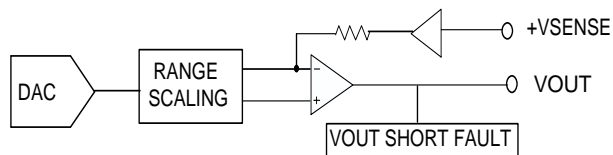

Figure 14. Voltage Output

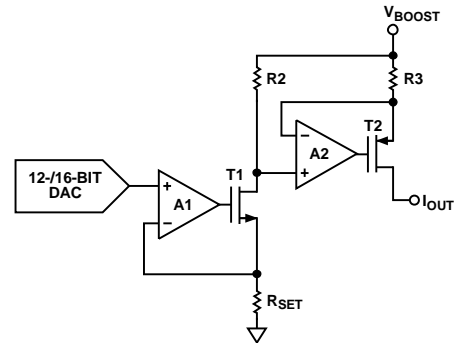

Figure 15. Voltage to Current conversion circuitry

### Voltage Output Amplifier

The voltage output amplifier is capable of generating both unipolar and bipolar output voltages. It is capable of driving a load of 1 k $\Omega$  in parallel with 2000 pF to AGND. The source and sink capabilities of the output amplifier can be seen in Figure TBD. The slew rate is 1 V/ $\mu$ s with a full-scale settling time of 10  $\mu$ s.(10V step).

### Driving Large Capacitive Loads

The voltage output amplifier is capable of driving capacitive loads of up to 1 $\mu$ F with the addition of a non-polarised compensation capacitors on each channel. Care should be taken to choose an appropriate value of compensation capacitor. This capacitor, while allowing the AD5755-1 to drive higher cap loads and reduce overshoot, will increase the settling time of the part and therefore effect the bandwidth of the system. Without the compensation capacitor, up to 20nF capacitive loads can be driven. See pin list for information on connecting compensation capacitors.

### Reference Buffers

The AD5755-1 can operate with either an external or internal reference. The reference input has an input range of 4 V to 5 V, 5 V for specified performance. This input voltage is then buffered before it is applied to the DAC.

### POWER ON STATE OF AD5755-1

On initial power-up of the AD5755-1 the power-on-reset circuit powers up in a state that is dependent on the POC (Power on Control) pin.

If POC = 0 both the Vout/Iout channels will power up in Tri-state mode.

If POC= 1 the Vout channel will Power up with 30k pull down to Ground, and the IOUT channel will power up to tri-state.

Even though the output ranges are not enabled, the default output range is 0-5V, and the Clear Code Register is loaded with all zeros. This means if the user CLEARS the part after power-up the output will be actively driven to zero volts. (If the channel has been enabled for clear)



**SERIAL INTERFACE**

The AD5755-1 is controlled over a versatile 3-wire serial interface that operates at clock rates of up to 30 MHz and is compatible with SPI®, QSPI™, MICROWIRE™, and DSP standards. Data coding is always straight binary.

**Input Shift Register**

The input shift register is 24 bits wide. Data is loaded into the device MSB first as a 24-bit word under the control of a serial clock input, SCLK. Data is clocked in on the falling edge of SCLK.

There are two ways in which the DAC outputs can be updated as outlined below.

**Individual DAC Updating**

In this mode,  $\overline{\text{LDAC}}$  is held low while data is being clocked into the DAC Data Register. The addressed DAC output is updated on the rising edge of SYNC.

**Simultaneous Updating of All DACs**

In this mode,  $\overline{\text{LDAC}}$  is held high while data is being clocked into the DAC Data Register. Only the first write to each channels data register will be valid after  $\overline{\text{LDAC}}$  is brought high. Any subsequent writes while  $\overline{\text{LDAC}}$  is still held high will be ignored. All the DAC outputs are updated by taking  $\overline{\text{LDAC}}$  low any time after SYNC has been taken high.

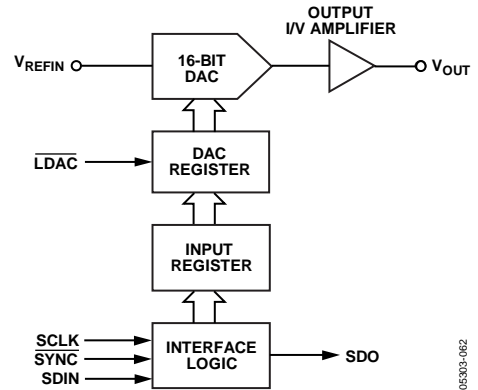

Figure 16. Simplified Serial Interface of Input Loading Circuitry for One DAC Channel

**TRANSFER FUNCTION**

Table 10 shows the input code to ideal output voltage relationship for the AD5755-1 or straight binary data coding -  $\pm 10\text{v}$  output range shown.

Table 7. Ideal Output Voltage to Input Code Relationship

Digital Input				Analog Output
Straight Binary Data Coding				
MSB		LSB		$V_{\text{OUT}}$
1111	1111	1111	1111	$+2 V_{\text{REF}} \times (32767/32768)$
1111	1111	1111	1110	$+2 V_{\text{REF}} \times (32766/32768)$
1000	0000	0000	0000	0 V
0000	0000	0000	0001	$-2 V_{\text{REF}} \times (32766/32768)$
0000	0000	0000	0000	$-2 V_{\text{REF}} \times (32767/32768)$

## REGISTERS

Table 8 below shows an overview of the Registers for the AD5755-1.

**Table 8. Data and Control Registers for AD5755-1**

<b>DATA REGISTERS</b>	<b>Description</b>
DAC Data Register (X4)	Used to write a DAC code to each DAC channel. AD5755-1 Data bits (D15 to D0), There are four DAC Data Registers, one per DAC Channel.
Gain Register (X4)	Used to program gain trim on per channel basis. AD5755-1 Data bits (D15 to D0), There are four Gain Registers, one per DAC channel.
Offset Register (X4)	Used to program offset tro, on per channel basis. AD5755-1 Data bits (D15 to D0), There are four Offset Registers, one per DAC channel.
Clear Code Register (X4)	Used to program Clear Code on per channel basis. AD5755-1 Data bits (D15 to D0), There are four Clear Code Registers, one per DAC channel.
<b>CONTROL REGISTERS</b>	
Main Control Register	Used to Configure the part for main operation. Sets functions such as status readback during write, enable output on all channels simultaneously, power on all DC-DC blocks simultaneously, enables and sets conditions of watchdog timer. See Features Section for more details.
Software Register	Has two functions. Used to perform a reset. Is also used as part of the watchdog timer feature to verify correct data communication operation.
Slew Rate Control Register (X4)	Use to program the slew rate of the output. There are four Slew Rate Control Registers, one per channel.
DAC Control Register (X4)	These registers are used to control the following... <ol style="list-style-type: none"> <li>1) Set the output range, e.g. 4-20ma, 0-10v etc..</li> <li>2) Set whether Internal/External sense Resistor used</li> <li>3) Enable/Disable channel for CLEAR..</li> <li>4) Enable/Disable Over-range.</li> <li>5) Enable/Disable output on a per channel basis..</li> <li>6) Power on DC-DC on a per channel basis.</li> </ol> There are four DAC Control Registers, one per DAC channel.
DC-DC Control Register	Use to set the DC-DC Control parameters. Can control DC-DC max voltage, phase and frequency.
<b>READBACK</b>	
Status Register	

**PROGRAMMING SEQUENCE TO WRITE/ENABLE THE OUTPUT CORRECTLY**

To correctly write to and set up the part from a power on condition the sequence below should be followed. It is recommended to perform a hardware or software reset after initial power on.

Firstly, the DC-DC supply block needs to be configured. The user should set the DC-DC switching frequency, max output voltage allowed and the phase that the 4 DC-DC channels clock at. Secondly the DAC Control Register should be configured on a per channel basis. The output range is selected, and the DC-DC block is enabled (DC-DC). Other control bits may be configured at this point, however, the output enable bit (OUTEN) and the INT\_ENABLE bit should not be set. Next, the user writes the required code to the DAC Data Register. This will implement a full DAC calibration internally. Finally the user writes to the DAC Control Register again to enable the output (set the OUTEN bit). A flow chart of this sequence is shown below.

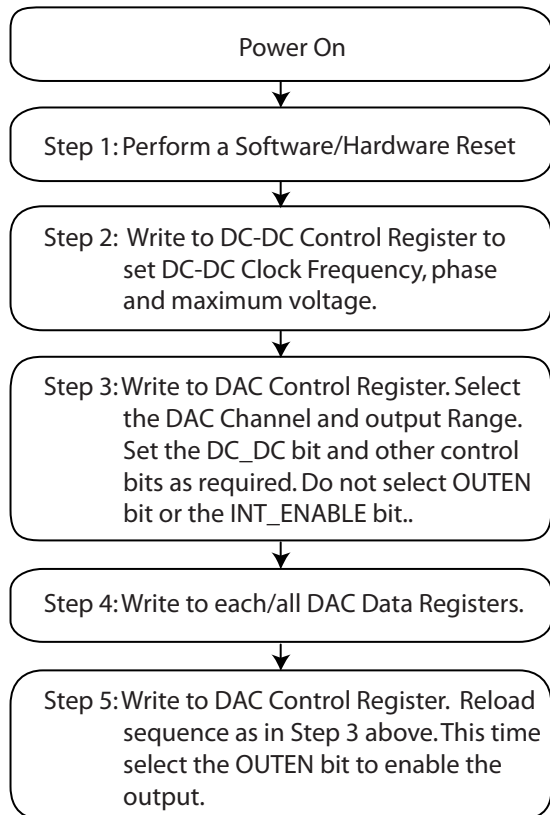

Figure 17. Programming Sequence for Enabling the Output Correctly

**CHANGING AND REPROGRAMMING THE RANGE**

When changing between ranges the same sequence as above should be used. It is recommended to set the range to its zero point (can be mid-scale or zeroscale) prior to disabling the output. As the DC-DC switching frequency, max voltage and phase have already been selected, there is no need to reprogram this. A flow chart of this sequence is shown below.

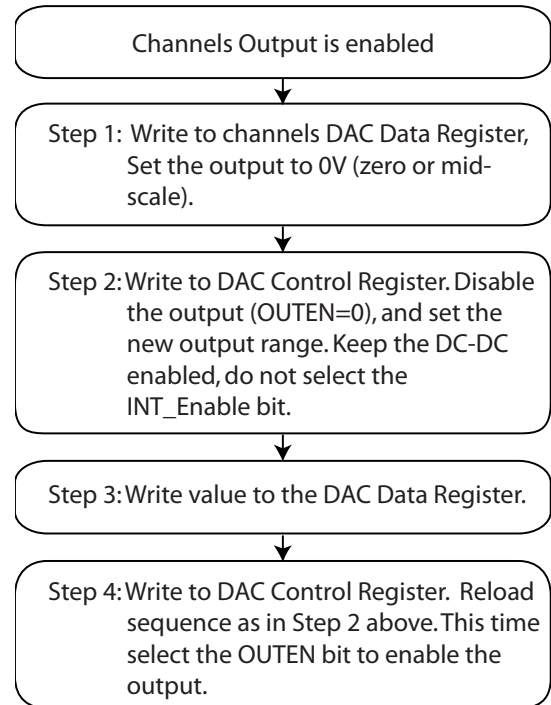

Figure 18. Steps for Changing the Output Range

**DATA REGISTERS**

The input register is 24 bits wide. When writing to a data register the following format must be used:

**Table 9. AD5755-1 Writing to a Data Register**

D23	D22	D21	D20	D19	D18	D17	D16	D15 to D0
R/W	DUT_AD1	DUT_AD0	DREG2	DREG1	DREG0	DAC_AD1	DAC_AD0	

**Table 10. AD5755-1 Input Register Decode**

Register	Function			
R/W	Indicates a read from or a write to the addressed register.			
DUT_AD1, DUT_AD0	Used in association with External Pins AD1, AD0 to determine which AD5755-1 device is being addressed by the system controller.			
	<b>DUT_AD1</b>	<b>DUT_AD0</b>		<b>Function</b>
	0	0		Addresses Part with Pins AD1=0, AD0=0
	0	1		Addresses Part with Pins AD1=0, AD0=1
	1	0		Addresses Part with Pins AD1=1, AD0=0
	1	1		Addresses Part with Pins AD1=1, AD0=1
DREG2, DREG1, DREG0	Selects whether a data register or a control register is written to. If a control register is selected, a further decode of CREG bits is required to select the particular control register, as detailed below.			
	<b>DREG2</b>	<b>DREG1</b>	<b>DREG0</b>	<b>Function</b>
	0	0	0	Write to DAC Data Register (Individual Channel Write)
	0	1	0	Write to Gain Register
	0	1	1	Write to Gain Register (ALL DACS)
	1	0	0	Write to Offset Register
	1	0	1	Write to Offset Register (ALL DACS)
	1	1	0	Write to Clear Code Register
	1	1	1	Write to a Control Register
DAC_AD1, DAC_AD0	These bits are used to decode the DAC channel			
	<b>DAC_AD1</b>	<b>DAC_AD0</b>	<b>DAC Channel/ Register Address</b>	
	0	0	DAC A	
	0	1	DAC B	
	1	0	DAC C	
	1	1	DAC D	
	X	X	These are don't cares if they are not relevant to the operation being performed.	

**DAC DATA REGISTER****Table 11. Programming the AD5755-1 DAC Data Registers**

When writing to the AD5755-1 DAC Data Registers D15-D0 are used for DAC DATA bits. See Table x for input register decode.

MSB

LSB

D23	D22	D21	D20	D19	D18	D17	D16	D15 to D0
R/W	DUT_AD1	DUT_AD0	DREG2	DREG1	DREG0	DAC_AD1	DAC_AD0	DATA

**GAIN REGISTER**

The Gain Register stores the Gain Code (M) which is used in the DAC transfer function to calculate the overall DAC input code (see formula below). The Gain Register is addressed by setting DREG bits to '0,1,0'. The DAC address bits select which DAC channel the gain write is addressed to. It is possible to write the same gain code to all 4 DAC channels at the same time by setting the DREG bits to 011.

The AD5755-1 Gain Register is a 16/12 bit register (bits G15.. G0/G3) and allows the user to adjust the gain of each channel in steps of 1 LSB as shown in the Table below. The Gain Register coding is straight binary. In theory the gain can be tuned across the full range of the output. In practice, the maximum recommended gain trim is about 50% of programmed range in order to maintain accuracy.

**Table 12. Programming the AD5755-1 Gain Register**

R/W	DUT_ AD1	DUT_ AD0	DREG2	DREG1	DREG0	DAC_ AD1	DAC_ AD0	D15-D0
0	DEVICE ADDRESS		010			DAC Channel Address		G15 to G0

**Table 13. AD5755-1 Gain Register**

Gain Adjustment	G15	G14	G13	G12 to G4	G3	G2	G1	G0
+65535 LSBs	1	1	1	1	1	1	1	1
+65534 LSBs	1	1	1	1	1	1	0	0
	-	-	-	-	-	-	-	-
1 LSBs	0	0	0	0	0	0	0	1
0 LSBs	0	0	0	0	0	0	0	0

**OFFSET REGISTER**

The Offset Register is addressed by setting the DREG BITS to DREG2 =1 DREG1=0, DREG0=0. The DAC address bits select with which DAC channel the offset write is addressed to. It is possible to write the same offset code to all 4 DAC channels at the same time by setting the DREG bits to 101. The AD5755-1 offset code is 16/12 bit (bits OF15.. OF0/OF3) and allows the user to adjust the offset of each channel by -32768/8192 LSBs to +32767/8191 LSBs in steps of 1 LSB as shown in the Table below.. The Offset Register coding is straight binary. The default code in the Offset Register is 0x8000/0x800. This will result in zero offset programmed to the output.

**Table 14. Programming the AD5755-1 Offset Register**

R/W	DUT_ AD1	DUT_ AD0	DREG2	DREG1	DREG0	DAC_ AD1	DAC_ AD0	D15 to D0
0	DEVICE ADDRESS		100			DAC Channel Address		OF15 to OF0

**Table 15. AD5755-1 Offset Register options**

Offset Adjustment	OF15	OF14	OF13	OF12 to OF4	OF3	OF2	OF1	OF0
+32768 LSBs	1	1	1	1	1	1	1	1
+32767 LSBs	1	1	1	1	1	1	0	0
	-	-	-	-	-	-	-	-
No Adjustment (default)	1	0	0	0	0	0	0	0
	-	-	-	-	-	-	-	-
-32767 LSBs	0	0	0	0	0	0	0	0
-32768 LSBs	0	0	0	0	0	0	0	0

**CLEAR CODE REGISTER**

There is a per channel Clear Code Register. The Clear Code Register is 16 bits wide and is addressed by setting the DREG bits to 1,1,0. It is also possible, via software, to enable/disable on a per channel basis which channels will be cleared when the CLEAR pin is activated. The default clear code is all 0's. See Features section for more information.

**Table 16. Programming AD5755-1 Clear Code Register**

D23	D22	D21	D20	D19	D18	D17	D16	D15 to D0
R/W	DUT_AD1	DUT_AD0	DREG2	DREG1	DREG0	DAC_AD1	DAC_AD0	CLEAR CODE
0	DEVICE ADDRESS		110			DAC Channel Address		DATA

**CONTROL REGISTERS**

When writing to a data register the following format must be used:

**Table 17. Writing to a control register**

MSB							LSB				
D23	D22	D21	D20	D19	D18	D17	D16	D15	D14	D13	D12to D0
R/W	DUT_AD1	DUT_AD0	1	1	1	DAC_AD1	DAC_AD0	CREG2	CREG1	CREG0	

See Table 10 for configuration on bits D23 to D16. The control registers are addressed by setting the DREG bits to DREG2 = 1, DREG1 = 1, DREG0=1 and then setting the CREG2, CREG1 and CREG0 bits to the appropriate decode address for that register as per **Table 18** below. These CREG bits select between the various control registers.

**Table 18. Register Access Decode**

CREG2, (D15)	CREG1, (D14)	CREG0, (D13)	
0	0	0	Slew Rate Control Register (one per channel)
0	0	1	Main Control Register
0	1	0	DAC Control Register (one per channel)
0	1	1	DC-DC Control Register
1	0	0	Software Register (one per channel)

**MAIN CONTROL REGISTER**

CREG2, CREG1, CREG0 are set to '0,0,1' to select the Main Control Register. The Main Control Register options are shown below.

**Table 19. Programming the Main Control Register**

MSB										LSB			
D15	D14	D13	D12	D11	D10	D9	D8	D7	D6	D5	D4	D3 to D0	
0	0	1	POC	STATREAD	EWD	WD1	WD0	X	ShtCctLim	OUTEN ALL	DC-DC ALL	X	

**Table 20. Main Control Register Functions.**

Option	Description															
STATREAD	Enable status readback during a write. See Features section. STATREAD =1, Enable STATREAD =0, Disable															
POC	The POC bit decides the state of the VOUT channel during normal operation. It's default value is 0. POC Bit = 0. The output will go to the value set by the POC pin when the current out channel is enabled. POC Bit = 1. The output will go to the opposite value of the POC pin if the channels $I_{out}$ is enabled.															
OUTEN ALL	Enables the output on all 4 DAC simultaneously. Do not use the OUTEN ALL bit when using the OUTEN bit in the DAC Control Registers.															
DC_DCALL	When set, Powers up the DC-DC on all 4 channels Simultaneously. To Power down the DC-DCs all channels outputs must first be disabled. Do not use the DC_DCALL bit when using the DC_DC bit in the DAC Control Registers.															
ShtCctLim	Programmable Short Circuit Limit on $V_{out}$ pin in the event of a short circuit condition. 0=15ma 1=8ma															
EWD	Enable Watchdog Timer. See features section for more information. EWD=1, Enable Watchdog EWD=0, Disable Watchdog															
WD1, WD0	Timeout Select Bits. Used to select timeout period for watchdog timer. <table border="1" style="margin-left: 20px;"> <thead> <tr> <th>WD1</th> <th>WD0</th> <th></th> </tr> </thead> <tbody> <tr> <td>0</td> <td>0</td> <td>5ms</td> </tr> <tr> <td>0</td> <td>1</td> <td>10ms</td> </tr> <tr> <td>1</td> <td>0</td> <td>100ms</td> </tr> <tr> <td>1</td> <td>1</td> <td>200ms</td> </tr> </tbody> </table>	WD1	WD0		0	0	5ms	0	1	10ms	1	0	100ms	1	1	200ms
WD1	WD0															
0	0	5ms														
0	1	10ms														
1	0	100ms														
1	1	200ms														

**DAC CONTROL REGISTER**

The DAC Control Register is used to configure each DAC Channel. The DAC Control Register is selected by setting bits CREG2, CREG1, CREG0 to 0,1,0.

**Table 21. Programming DAC Control Register**

D15	D14	D13	D12	D11	D10	D9	D8	D7	D6	D5	D4	D3	D2	D1	D0
0	1	0	X	X	X	X	INT_ENABLE	CLR_EN	OUTEN	RSET	DC-DC	OVRNG	R2	R1	R0

**Table 22. DAC Control Register Functions**

Option	Description																																
<b>RSET</b>	Selects internal or external current sense resistor for selected DAC channel RSET = 0 Selects external Resistor RSET = 1 Selects Internal Resistor																																
<b>R2,R1,R0</b>	Selects output range enabled. <table border="1" style="margin-left: 20px;"> <thead> <tr> <th>R2</th> <th>R1</th> <th>R0</th> <th>Output Range Selected</th> </tr> </thead> <tbody> <tr> <td>0</td> <td>0</td> <td>0</td> <td>0 to 5V Voltage Range</td> </tr> <tr> <td>0</td> <td>0</td> <td>1</td> <td>0 to 10V Voltage Range</td> </tr> <tr> <td>0</td> <td>1</td> <td>0</td> <td>±5V Voltage Range</td> </tr> <tr> <td>0</td> <td>1</td> <td>1</td> <td>±10V Voltage Range</td> </tr> <tr> <td>1</td> <td>0</td> <td>0</td> <td>4 to 20 mA Current Range</td> </tr> <tr> <td>1</td> <td>0</td> <td>1</td> <td>0 to 20 mA Current Range</td> </tr> <tr> <td>1</td> <td>1</td> <td>0</td> <td>0 to 24 mA Current Range</td> </tr> </tbody> </table>	R2	R1	R0	Output Range Selected	0	0	0	0 to 5V Voltage Range	0	0	1	0 to 10V Voltage Range	0	1	0	±5V Voltage Range	0	1	1	±10V Voltage Range	1	0	0	4 to 20 mA Current Range	1	0	1	0 to 20 mA Current Range	1	1	0	0 to 24 mA Current Range
R2	R1	R0	Output Range Selected																														
0	0	0	0 to 5V Voltage Range																														
0	0	1	0 to 10V Voltage Range																														
0	1	0	±5V Voltage Range																														
0	1	1	±10V Voltage Range																														
1	0	0	4 to 20 mA Current Range																														
1	0	1	0 to 20 mA Current Range																														
1	1	0	0 to 24 mA Current Range																														
<b>OVRNG</b>	Enables 20% overrange on Vout Channel only. No current overrange available. OVRNG=1, Enabled OVRNG=0, Disabled																																
<b>INT_ENABLE</b>	Powers up the DC-DC, DAC and internal amplifiers for the selected channel. Does not enable the output. Can only be done on a per channel basis.																																
<b>CLR_EN</b>	Per channel Clear Enable bit. Selects if this channel will clear when the CLEAR pin is activated. CLR_EN=1, channel will clear when part is cleared. CLR_EN=0, channel will not clear when part is cleared.																																
<b>OUTEN</b>	Enables/Disables the selected output channel OUTEN=1, Enables channel OUTEN=0, Disable channel																																
<b>DC_DC</b>	Powers the DC-DC on selected channel. DC_DC = 1, Power up DC_DC DC_DC = 0, Power down DC_DC This allows per channel DC_DC power up/down. To power down the DCDC, OUTEN and INT_ENABLE bits must also be set to 0. All DC-DCs can also be powered up simultaneously using DCDC_All bit in the Main Control Register.																																

**SOFTWARE REGISTER**

The Software Register has three functions. It allows the user to perform a software reset to the part. It can be used to set bit D11 in the Status Register. Lastly it is also used as part of the watchdog feature to ensure that the SPI interface connections are working properly. To ensure all the datapath lines are working properly (i.e. SDI/SCLK/SYNC), the user must write 0x195 to the Software Register within the timeout period. If this command is not received within the timeout period, the ALERT pin will signal a fault condition. Note. This is only required when the Watchdog Timer function is enabled.

**Table 23. Programming the Software Register**

To program a software reset you need to write 1,0,0 to CREG2, CREG1, CREG0.

MSB			LSB	
D15	D14	D13	D12	D11 to D0
1	0	0	User Program Bit	RESET CODE/SPI CODE

Table 24. Software Register Functions

User Program Bit	This bit is mapped to bit D11 of the Status Register. When this bit is set to 1 bit D11 of the Status Register is set to 1. Likewise when D12 is set to 0 bit D11 of the Status Register is also set to zero. This feature can be used to ensure the SPI pins are working correctly by writing known bit to this register and reading back corresponding bit from the Status Register.	
RESET CODE/SPI CODE	<b>Option</b>	<b>Description</b>
	RESET CODE	Writing 0x555 to D11-D0 performs a reset.
	SPI CODE	If Watchdog Timer feature enabled, 0x195 must be written to the Software Register (D11-D0) within every timeout period to ensure valid data communication path.

**DC-DC CONTROL REGISTER**

The DC-DC Control Register allows the user control over the DC-DC Switching Frequency, and of the phase of when the per channel switching starts. The maximum allowable DC-DC output frequency is also programmable.

Table 25. Programming the DC-DC Control Register

MSB				LSB		
D15	D14	D13	D12 to D7	D5 to D4	D3 to D2	D1 to D0
0	1	1	X	DC-DC Phase	DC-DC Freq	DC-DC MaxV

Table 26. DC-DC Control Register Options

Option	Description
DC-DCMaxV	Maximum allowed output Voltage of the DC-DC 00 = 25V ±1V 01 = 27.3 ±1V 10 = 28.6 ±1V 11 = 30 ±1V
DC-DC Freq	User Programmable DC-DC Switching Frequency: 00 = 250 KHz 01 = 406 KHz 10 = 649 KHz 11 = 812 KHz
DC-DC Phase	User Programmable DC-DC Phase (Between Channels) 00 = All DC-DCs clock on same edge 01 = ChanA, ChanB clock on same edge, ChanC & ChanD clock on opposite edge 10 = ChanA, ChanC clock on same edge, ChanB & ChanD on opposite edge 11 = ChanA, ChanB, ChanC, ChanD clock 90° out of phase from each other

**SLEW RATE CONTROL REGISTER**

This register is used to program the slew rate control for the selected DAC Channel. The CREG bits are set to '0,0,0' to select the Slew Rate Control Register. SR\_CLOCK and SR\_STEP allow the user to control the rate of the output SLEW. This feature is available on both the current and voltage outputs. With the slew rate control feature disabled the output value will change at a rate limited by the output drive circuitry and the attached load. SE enables output slew rate control. It can be both programmed and enabled/disabled on a per channel basis. For more information see the features section.

Table 27. Programming the Slew Rate Control Register

D15	D14	D13	D12	D11-D7	D6 to D3	D2 to D0
0	0	0	SE	X	SR_CLOCK	SR_STEP



**READBACK OPERATION**

Readback mode is invoked by setting the  $R/\overline{W}$  bit = 1 in the serial input register write. With  $R/\overline{W} = 1$ , bits DUT\_AD1, DUT\_AD0, in association with bits RD4, RD3, RD2, RD1, RD0 (See Table 29), select the register to be read. The remaining data bits in the write sequence are don't care. During the next SPI transfer, the data appearing on the SDO output contains the data from the previously addressed register. The readback diagram in Figure 3 shows the readback sequence.

**Table 28. Input Shift Register Contents for a read operation**

D23	D22	D21	D20	D19	D18	D17	D16	D15 to D0
$R/\overline{W}$	DUT_AD1	DUT_AD0	RD4	RD3	RD2	RD1	RD0	X

**Table 29. Read Address Decoding**

RD4	RD3	RD2	RD1	RD0	Function
0	0	0	0	0	Read DACA Data Register
0	0	0	0	1	Read DACB Data Register
0	0	0	1	0	Read DACC Data Register
0	0	0	1	1	Read DACD Data Register
0	0	1	0	0	Read Control Register DAC A
0	0	1	0	1	Read Control Register DAC B
0	0	1	1	0	Read Control Register DAC C
0	0	1	1	1	Read Control Register DAC D
0	1	0	0	0	Read Gain Register A
0	1	0	0	1	Read Gain Register B
0	1	0	1	0	Read Gain Register C
0	1	0	1	1	Read Gain Register D
0	1	1	0	0	Read Offset Register A
0	1	1	0	1	Read Offset Register B
0	1	1	1	0	Read Offset Register C
0	1	1	1	1	Read Offset Register D
1	0	0	0	0	Clear Code Register DAC A
1	0	0	0	1	Clear Code Register DAC B
1	0	0	1	0	Clear Code Register DAC C
1	0	0	1	1	Clear Code Register DAC D
1	0	1	0	0	Slew Rate Control Register DAC A
1	0	1	0	1	Slew Rate Control Register DAC B
1	0	1	1	0	Slew Rate Control Register DAC C
1	0	1	1	1	Slew Rate Control Register DAC D
1	1	0	0	0	Read Status Register
1	1	0	0	1	Read Main Control Register
1	1	0	1	0	Read DC-DC Control Register

**Read Back Example**

To read back the Gain Register of Device #1 Channel A on the AD5755-1, the following sequence should be implemented:

1. Write 0xA80000 to the AD5755-1 input register. This configures the AD5755-1 device address #1 for read mode with the Gain Register of channel A selected.. Note that all the data bits, D15 to D0, are don't care.
2. Follow this with any read/write command. During this command, the data from the selected Gain Register is clocked out on the SDO line.

**STATUS REGISTER**

The Status Register is a read only register. This register contains any fault information as well as a RAMP ACTIVE bit and a User Toggle Bit. By setting the STATREAD bit in the Main Control Register, the Status Register contents can be readback on the SDO pin during every write sequence.

**Table 30. Decoding the Status Register**

MSB															LSB	
D15 to D12	D15	D14	D13	D12	D11	D10	D9	D8	D7	D6	D5	D4	D3	D2	D1	D0
X	DC-DCD	DC-DCC	DC-DCB	DC-DCA	User Toggle Bit	PEC ERROR	RAMP ACTIVE	OVER TEMP	SHORT CCT VD	SHORT CCT VC	SHORT CCT VB	SHORT CCT VA	OPEN CCT ID	OPEN CCT IC	OPEN CCT IB	OPEN CCT IA

**Table 31. Status Register Options**

Option	Description
OPEN CCT IA	This bit will be set if a fault is detected on DACA I <sub>OUT</sub> pin.
OPEN CCT IB	This bit will be set if a fault is detected on DACB I <sub>OUT</sub> pin.
OPEN CCT IC	This bit will be set if a fault is detected on DACC I <sub>OUT</sub> pin.
OPEN CCT ID	This bit will be set if a fault is detected on DACD I <sub>OUT</sub> pin.
SHORT CCT VA	This bit will be set if a fault is detected on DACA V <sub>OUT</sub> pin.
SHORT CCT VB	This bit will be set if a fault is detected on DACB V <sub>OUT</sub> pin.
SHORT CCT VC	This bit will be set if a fault is detected on DACC V <sub>OUT</sub> pin.
SHORT CCT VD	This bit will be set if a fault is detected on DACD V <sub>OUT</sub> pin.
RAMP ACTIVE	This bit will be set while any one of the output channels are slewing (slew rate control enabled on at least one channel)
OVER TEMP	This bit will be set if the AD5755-1 core temperature exceeds approx. 150°C.
PEC ERROR	Denotes a PEC Error on the SPI Interface Transmit.
DC-DC A	DC-DC Failure on Channel A. This fault indicates that the DCDC is not operating, for example if the boost inductor is not connected.
DC-DCB	DC-DC Failure on Channel B. This fault indicates that the DCDC is not operating, for example if the boost inductor is not connected.
DC-DCC	DC-DC Failure on Channel C. This fault indicates that the DCDC is not operating, for example if the boost inductor is not connected.
DC-DCD	DC-DC Failure on Channel D. This fault indicates that the DCDC is not operating, for example if the boost inductor is not connected.
User Toggle Bit	User Writable bit that the user can set and readback while doing a Status Register read. This can be used to verify data communications if needed.

## FEATURES

### OUTPUT FAULT

The AD5755-1 is equipped with a FAULT pin, this is an active low open-drain output allowing several AD5755-1 devices to be connected together to one pull-up resistor for global fault detection. The FAULT pin is forced active by any one of the following fault scenarios;

- 1) The Voltage at I<sub>OUT</sub> attempts to rise above the compliance range, due to an open-loop circuit or insufficient power supply voltage. The internal circuitry that develops the fault output avoids using a comparator with “window limits” since this would require an actual output error before the FAULT output becomes active. Instead, the signal is generated when the internal amplifier in the output stage has less than approximately one volt of remaining drive capability. Thus the FAULT output activates slightly before the compliance limit is reached. Since the comparison is made within the feedback loop of the output amplifier, the output accuracy is maintained by its open-loop gain and an output error does not occur before the FAULT output becomes active.
- 2) A short is detected on the voltage output pin. Short circuit current limited to 15ma or 8ma, this is programmable by the user.
- 3) An interface error is detected due to a PEC failure. See Packet Error Checking section.
- 4) If the core temperature of the AD5755-1 exceeds approx. 150°C.

The OPEN CCT and OVER TEMP bits of the Status Register are used in conjunction with the FAULT output to inform the user which one of the fault conditions caused the FAULT output to be activated.

### VOLTAGE OUTPUT SHORT CIRCUIT PROTECTION

Under normal operation the voltage output will sink/source up to 10mA and maintain specified operation. The maximum current that the voltage output will deliver is 15mA, this is the short circuit current. This short circuit current is programmable by the user and can be set to 15mA or 8mA. If a short circuit is detected the FAULT will go low and the relevant SHORT CCT bit in the Status register will be set.

### DIGITAL OFFSET AND GAIN CONTROL

Each DAC channel has a gain (M) and offset (C) register, which allow trimming out of the gain and offset errors of the entire signal chain. Data from the DAC Data Register is operated on by a digital multiplier and adder controlled by the contents of

the M and C registers. The calibrated DAC data is then stored in the DAC2 register.

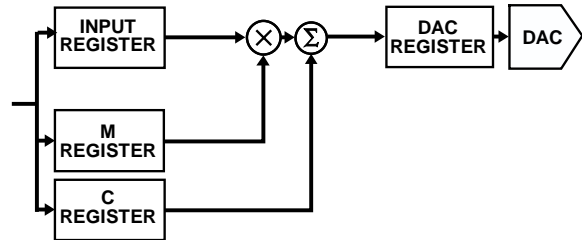

Figure 19. Digital Offset and Gain control

Although this diagram indicates a multiplier and adder for each channel, there is only one multiplier and one adder in the device, and they are shared among all 4 channels. This has implications for the update speed when several channels are updated at once.

Each time data is written to the M or C register the output is not automatically updated. Rather, the next write to the DAC channel will use these M&C values to perform a new calibration and automatically update the channel.

Data output from the DAC2 register is routed to the final DAC register by a multiplexer. Both the Gain Register and the Offset Register have 16 bits of resolution. The correct method to calibrate the gain/offset is firstly to calibrate out the gain and then calibrate the offset.

The value (in decimal) that is written to the DAC register can be calculated by:

$$Code_{DAC\ Register} = D \times \frac{(M + 1)}{2^{16}} + C - 2^{15}$$

where:

D is the code loaded to the DAC channels input register.

M is the code in Gain Register – default code =  $2^{16} - 1$

C is the code in Offset Register – default code =  $2^{15}$

### STATUS READBACK DURING WRITE

The AD5755-1 has the ability to read back the Status Register contents during every write sequence. This feature is enabled via the STATREAD bit in the Main Control Register. This allows the user to continuously monitor the Status Register and act quickly in the case of a fault.

When Status Readback During Write is enabled the contents of the 16bit Status register (See Table 31) is outputted on the SDO pin as indicated in Figure 4.

The AD5755-1 will power up with this feature disabled. When this is enabled the normal readback feature is not available, except of the status register. To readback any other register set STATREAD low first before following the readback sequence. STATREAD may be set high again after the register read.

**ASYNCHRONOUS CLEAR**

CLEAR is an active high edge sensitive input that allows the output to be cleared to a pre programmed 16 bit code. This code is user programmable via a per-channel 16 bit Clear Code Register.

In order for a channel to clear, that channel must be enabled to be cleared via the CLR\_EN bit in the channels DAC Control Register. If the channel is not enabled to be cleared then the output will remain in its current state independent of the CLEAR pin level.

When the CLEAR signal is returned low, the relevant outputs remains cleared until a new value is programmed.

**PACKET ERROR CHECKING**

To verify that data has been received correctly in noisy environments, the AD5755-1 offers the option of packet error checking based on an 8-bit (CRC-8) cyclic redundancy check. The device controlling the AD5755-1 should generate an 8-frame check sequence using the polynomial

$$C(x) = x_8 + x_2 + x_1 + 1$$

This is added to the end of the data word, and 32 bits are sent to the AD5755-1 before taking SYNC high. If the AD5755-1 sees a 32-bit frame, it will perform the error check when SYNC goes high. If the check is valid, then the data will be written to the selected register. If the error check fails, the FAULT pin will go low and the PEC ERROR bit in the Status Register will be set. After reading the Status Register, FAULT will return high (assuming there are no other faults) and the PEC ERROR bit will be cleared automatically.

The PEC can be used for both transmit and receive of data packets. If Status Readback During Write is enabled, the ‘PEC’ values returned during the Status Readback During Write should be ignored. All other PEC values will be valid though and the user can still use the normal readback operation to monitor Status Register activity with PEC.

**WATCHDOG TIMER**

If enabled, an on chip watchdog timer will generate an alert signal if 0x195 has not been written to the Software Register within the programmed timeout period. This feature is useful to ensure communication has not been lost between the MCU and the AD5755-1 and that these datapath lines are working properly (i.e. SDI/SCLK/SYNC). If 0x195 is not received by the Software Register within the timeout period, the ALERT pin will signal a fault condition. The ALERT signal is active high and can be connected directly to the CLEAR pin to enable a CLEAR in the event that data communications are lost from the MCU.

The watchdog timer is enabled and the timeout period (50,100,150 or 200ms) set in the control register (See Table 19).

**OUTPUT ALERT**

The AD5755-1 is equipped with a ALERT pin, this is An active high CMOS output. The AD5755-1 has an internal watchdog timer. If enabled, it will monitor SPI communications. If 0x195 is not received by the Software Register within the timeout period, the ALERT pin will go active.

**INTERNAL REFERENCE**

The AD5755-1 contains an integrated +5V voltage reference with initial accuracy of ±2mV max and a temperature drift coefficient of ±5 ppm max. The reference voltage is buffered and externally available for use elsewhere within the system.

**EXTERNAL CURRENT SETTING RESISTOR**

Referring to Figure 15, R1 is an internal sense resistor as part of the voltage to current conversion circuitry. The stability of the output current value over temperature is dependent on the stability of the value of R1. As a method of improving the stability of the output current over temperature an external 15kΩ low drift resistor can be connected to the R<sub>SET</sub> pin of the AD5755-1 to be used instead of the internal resistor R1. The external resistor is selected via the DAC Control register. See Table 21.

**HART**

The AD5755-1 has 4 CHART pins, one corresponding to each output channels. A HART signal can be coupled into these pins. The HART signal will appear on the corresponding current output, if the output is enables. Table 32 below shows the recommended input voltages for the HART signal at the CHART pin. If these voltages are used the current output should meet the HART amplitude specifications. Figure 20 is the recommended circuit for attenuating and coupling in the HART signal.

**Table 32. CHART input voltage to HART output current**

	CHART input voltage	Current output (HART)
Internal Rset	150mVp-p	1mA <sub>p-p</sub>
External Rset	170mVp-p	1mA <sub>p-p</sub>

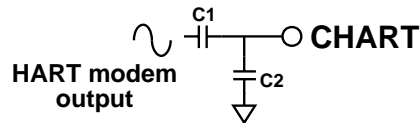

Figure 20. Coupling HART signal

A minimum capacitance of C1+C2 will be required to ensure that the 1.2kHz and 2.2kHz “HART frequencies” are not significantly attenuated at the output. This will be in the order of 10’s of nF’s.

Digitally controlling the slew rate of the output is necessary to meet the analog rate of change requirements for HART.

**SLEW RATE CONTROL**

The Slew Rate Control feature of the AD5755-1 allows the user to control the rate at which the output value changes. This feature is available on both the current and voltage outputs. With the slew rate control feature disabled the output value will change at a rate limited by the output drive circuitry and the attached load. If the user wishes to reduce the slew rate this can be achieved by enabling the slew rate control feature. With the feature enabled via the SREN bit of the Slew Rate Control Register, (See Table 27) the output, instead of slewing directly between two values, will step digitally at a rate defined by two parameters accessible via the Slew Rate Control Register as shown in Table 27. The parameters are SR\_CLOCK and SR\_STEP. SR\_CLOCK defines the rate at which the digital slew will be updated, e.g. if the selected update rate is 8KHz the output will update every 125µs, in conjunction with this the SR\_STEP defines by how much the output value will change at each update. Together both parameters define the rate of change of the output value. Table 33 and Table 34 outline the range of values for both the SR\_CLOCK and SR\_STEP parameters.

**Table 33. Slew Rate Update Clock Options**

SR_CLOCK	Update Clock Frequency (Hz)*
0000	64K
0001	32K
0010	16K
0011	8k
0100	4k
0101	2k
0110	1k
0111	500
1000	250
1001	125
1010	64
1011	32
1100	16
1101	8
1110	4
1111	0.5Hz

\*Clock Frequencies accurate to ±TDB%.

**Table 34. Slew\_Rate Step Size Options**

SR_STEP	AD5755-1 (16 BIT) Step Size (LSBs)
000	1
001	2
010	4
011	16
100	32
101	64
110	128
111	256

The following equation describes the slew rate as a function of the step size, the update clock frequency and the LSB size.

$$Slew\ Time = \frac{Output\ Change}{Step\ Size \times Update\ Clock\ Frequency \times LSB\ Size}$$

Where:

Slew Time is expressed in seconds

Output Change is expressed in Amps for I<sub>OUT</sub> or Volts for V<sub>OUT</sub>

When the slew rate control feature is enabled, all output changes will change at the programmed slew rate, for example if the CLEAR pin is asserted the output will slew to the clear value at the programmed slew rate (assuming that Clear channel is enabled to be cleared). The update clock frequency for any given value will be the same for all output ranges, the step size however will vary across output ranges for a given value of step size as the LSB size will be different for each output range.

**POWER DISSIPATION CONTROL**

The AD5755-1 contains integrated dynamic power control using a DC-DC boost circuit allowing reductions in power consumption from standard designs when using the part in current output mode.

In standard current input module designs the load resistor values can range from typically 50 ohm to 750 ohm. Output module systems must source enough voltage to meet the compliance voltage requirement across the full range of load resistor values. For example, in a 4-20ma loop when driving 20ma a compliance voltage of >15V is required. When driving 20ma into a 50 ohm load only 1V compliance is required.

The AD5755-1 circuitry senses the output voltage and regulates this voltage to meet compliance requirements plus a small headroom voltage.

**DC-DC CONVERTERS**

The AD5755-1 contains 4 independent DCDC converters. These are used to provide dynamic control of the V<sub>boost</sub> supply voltage for each channel (See Figure 15). Figure 21 below shows the discreet components needed for the DCDC circuitry and

the following sections describe component selection for this circuitry.

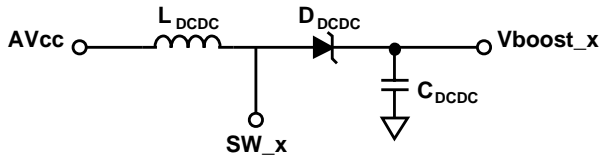

Figure 21. DC-DC Circuit

### DC-DC Operation

The on-board DC-DC converters use a constant frequency, peak current mode control scheme to step-up an  $AV_{cc}$  input in the range 2.7 to 5.5v to drive the AD5755-1 output channel. These are designed to operate in discontinuous conduction mode (DCM) with a duty cycle < 85%. Discontinuous conduction mode refers to a mode of operation where the inductor current goes to zero for an appreciable % of the switching cycle. The DCDC converters are non synchronous i.e. they require an external schottky diode.

### DC-DC Output Voltage

When a channel current output is enabled the converter regulates the  $V_{boost}$  supply to 7.5V or ( $I_{out} \times R_{load} + 2V$ ), whichever is greater. The maximum  $V_{boost}$  voltage is set in the DC-DC Control Register (25, 27.3, 28.6 or 30V. See Table 26).

In voltage output mode, or in current output mode with the output disabled, the converter regulates the  $V_{boost}$  supply to +15v ( $\pm 8\%$ ).

Within a channel the  $V_{out}$  &  $I_{out}$  stages share a common  $V_{boost}$  supply so that the outputs of the  $I_{out}$  &  $V_{out}$  stages can be tied together.

### DC-DC On-Board Switch

The AD5755-1 contains a 0.5ohm internal switch . The switch current is monitored on a pulse by pulse basis & is limited to 0.8A peak current.

### DC-DC Switching Frequency and Phase

The AD5755-1 DCDC switching frequency can be selected from the DCDC Control Register to be 250Khz, 400Khz, 649kHz or 812kHz. The phasing of the channels can also be adjusted so that the DCDCs can clock on different edges (See Table 26). For typical applications a 250Khz frequency is recommended. At light loads (low output current & small load resistor) the DCDC enters a pulse skipping mode to minimize switching power dissipation.

### DC-DC Inductor Selection

For typical 4-20mA applications a 10uH inductor combined with a switching frequency of 250Khz will allow up to 24mA to be driven into a load resistance of up to 1k $\Omega$  with an  $AV_{cc}$  supply from 2.7 to 5.5v. The inductor must be able to handle the

peak current without saturating at the maximum ambient temperature.

If an alternative Inductor/Switching frequency is preferred then one must ensure that the DCDC continues to operate in DCM mode and that the inductor current is less than 0.8A.

$$\frac{2 \times I_{OUT\ max} (V_{OUT\ max} - V_{CC\ min})}{I_{PEAK\ max}^2 \times F_{SW}} < L < \frac{V_{IN\ min}^2 (V_{OUT\ max} - V_{IN\ min}) \times \eta}{2 \times I_{OUT\ max} \times V_{OUT\ max}^2 \times F_{SW}}$$

Where:

$I_{PEAK\ max}$  = Maximum Peak Current (0.8A limit)

$F_{SW}$  = Switching Frequency set in the DCDC Control Register.

$\eta$  = efficiency (Assume = 0.8)

### DC-DC External schottky selection

The AD5755-1 requires an external schottky for correct operation. Ensure the schottky is rated to handle the maximum reverse breakdown expected in operation & that the rectifier maximum junction temperature is not exceeded. The diode average current =  $I_{load}$  current.

### DC-DC Compensation Capacitors

As the DCDC operates in DCM the uncompensated transfer function is essentially a single pole transfer function. The pole frequency is determined by  $C_{out}$ ,  $V_{in}$ ,  $V_{out}$  &  $I_{load}$ . The AD5755-1 uses an external capacitor in conjunction with an internal 150k resistor to compensate the regulator loop. For typical 4-20mA applications connect a 10nF capacitor from each of the  $COMP_{DCDC\_A/B/C/D}$  pins to GND.

### DC-DC Input and Output Capacitor Selection

The output capacitor effects ripple voltage of the DCDC converter & also indirectly limits the maximum slew rate at which the channel output current can rise. The ripple voltage is caused by a combination of the capacitance & ESR (equivalent series resistance) of the capacitor. For the AD5755-1 a ceramic capacitor of 4.7 $\mu$ F is recommended for typical applications. Larger capacitors or paralalled capacitors will improve the ripple at the expense of reduced slew rate.

The input capacitor will provide much of the dynamic current required for the DCDC converter & should also be a low ESR component. For the AD5755-1 a ceramic capacitor of 10 $\mu$ F is recommended for typical applications. Ceramic capacitors must be chosen carefully as they can exhibit a large sensitivity to DC bias voltages & temperature. X5R or X7R dielectrics are preferred as these capacitors remain stable over wider operating voltage & temperature ranges.

***I<sub>out</sub> Slew Rate when using the DC-DC***

When the AD5755-1 is configured in I<sub>out</sub> mode & a step increase in output current is programmed then the DCDC converter must increase its output voltage so that  $V_{boost} \approx I_{out} * R_{load} + 2v$ . This requires that the output capacitor of the

DCDC circuit must also be charge to the new voltage. The amount of power required to do this is  $0.5 * C * (V_{new} - V_{old})$ . Figure 7. And Figure 8. show I<sub>out</sub> settling for a 0 to 24mA step into a 1kohm load for different caps & inductor/switching frequency.

## APPLICATIONS INFORMATION

### PRECISION VOLTAGE REFERENCE SELECTION

To achieve the optimum performance from the AD5755-1 over its full operating temperature range, a precision voltage reference must be used. Thought should be given to the selection of a precision voltage reference. The voltage applied to the reference input is used to provide a buffered reference for the DAC cores. Therefore, any error in the voltage reference is reflected in the outputs of the device.

There are four possible sources of error to consider when choosing a voltage reference for high accuracy applications: initial accuracy, temperature coefficient of the output voltage, long term drift, and output voltage noise.

Initial accuracy error on the output voltage of an external reference could lead to a full-scale error in the DAC. Therefore, to minimize these errors, a reference with low initial accuracy error specification is preferred. Choosing a reference with an output trim adjustment, such as the ADR425, allows a system designer to trim system errors out by setting the reference voltage to a voltage other than the nominal. The trim adjustment can also be used at temperature to trim out any error.

Long-term drift is a measure of how much the reference output voltage drifts over time. A reference with a tight long-term drift specification ensures that the overall solution remains relatively stable over its entire lifetime.

The temperature coefficient of a reference's output voltage affects INL, DNL, and TUE. A reference with a tight temperature coefficient specification should be chosen to reduce the dependence of the DAC output voltage on ambient conditions.

In high accuracy applications, which have a relatively low noise budget, reference output voltage noise needs to be considered. Choosing a reference with as low an output noise voltage as practical for the system resolution required is important. Precision voltage references such as the ADR435 (XFET design) produce low output noise in the 0.1 Hz to 10 Hz region. However, as the circuit bandwidth increases, filtering the output of the reference may be required to minimize the output noise.

**Table 35. Some Recommended Precision References**

Part No.	Initial Accuracy (mV Max)	Long-Term Drift (ppm Typ)	Temp Drift (ppm/°C Max)	0.1 Hz to 10 Hz Noise (μV p-p Typ)
ADR435	±6	30	3	3.4
ADR425	±6	50	3	3.4
ADR02	±5	50	3	15
ADR395	±6	50	25	5
AD586	±2.5	15	10	4

### DRIVING INDUCTIVE LOADS

When driving inductive or poorly defined loads connect a 0.01μF capacitor between I<sub>OUT</sub> and GND. This will ensure stability with loads beyond 50mH. There is no maximum capacitance limit. The capacitive component of the load may cause slower settling, though this may be masked by the settling time of the AD5755-1.

### TRANSIENT VOLTAGE PROTECTION

The AD5755-1 contains ESD protection diodes which prevent damage from normal handling. The industrial control environment can, however, subject I/O circuits to much higher transients. In order to protect the AD5755-1 from excessively high voltage transients, external power diodes and a surge current limiting resistor may be required, as shown in Figure 22. The constraint on the resistor value is that during normal operation the output level at IOUT must remain within its voltage compliance limit of  $AV_{DD} - 2.5V$  and the two protection diodes and resistor must have appropriate power ratings.

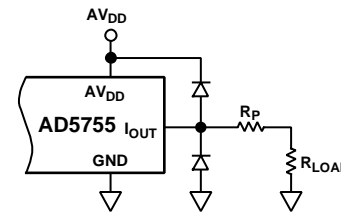

Figure 22. Output Transient Voltage Protection

### MICROPROCESSOR INTERFACING

Microprocessor interfacing to the AD5755-1 is via a serial bus that uses a protocol compatible with microcontrollers and DSP processors. The communications channel is a 3-wire minimum interface consisting of a clock signal, a data signal, and a latch signal. The AD5755-1 requires a 24-bit data-word with data valid on the falling edge of SCLK.

The DAC output update is initiated on either the rising edge of LDAC or, if LDAC is held low, on the rising edge of SYNC. The contents of the registers can be read using the readback function.

### LAYOUT GUIDELINES

In any circuit where accuracy is important, careful consideration of the power supply and ground return layout helps to ensure the rated performance. The printed circuit board on which the AD5755-1 is mounted should be designed so that the analog and digital sections are separated and confined to certain areas of the board. If the AD5755-1 is in a system where multiple devices require an AGND-to-DGND connection, the connection should be made at one point only. The star ground point should be established as close as possible to the device.



The AD5755-1 should have ample supply bypassing of 10  $\mu\text{F}$  in parallel with 0.1  $\mu\text{F}$  on each supply located as close to the package as possible, ideally right up against the device. The 10  $\mu\text{F}$  capacitors are the tantalum bead type. The 0.1  $\mu\text{F}$  capacitor should have low effective series resistance (ESR) and low effective series inductance (ESI) such as the common ceramic types, which provide a low impedance path to ground at high frequencies to handle transient currents due to internal logic switching.

The power supply lines of the AD5755-1 should use as large a trace as possible to provide low impedance paths and reduce the effects of glitches on the power supply line. Fast switching signals such as clocks should be shielded with digital ground to avoid radiating noise to other parts of the board and should never be run near the reference inputs. A ground line routed between the SDIN and SCLK lines helps reduce crosstalk between them (not required on a multilayer board that has a separate ground plane, but separating the lines helps). It is essential to minimize noise on the REFIN line because it couples through to the DAC output.

Avoid crossover of digital and analog signals. Traces on opposite sides of the board should run at right angles to each other. This reduces the effects of feed through the board. A microstrip technique is by far the best, but not always possible with a double-sided board. In this technique, the component

side of the board is dedicated to ground plane, while signal traces are placed on the solder side.

### GALVANICALLY ISOLATED INTERFACE

In many process control applications, it is necessary to provide an isolation barrier between the controller and the unit being controlled to protect and isolate the controlling circuitry from any hazardous common-mode voltages that might occur. Isocouplers provide voltage isolation in excess of 2.5 kV. The serial loading structure of the AD5755-1 makes it ideal for isolated interfaces, because the number of interface lines is kept to a minimum. Figure 23 shows a 4-channel isolated interface to the AD5755-1 using an ADuM1400. For more information, go to [www.analog.com](http://www.analog.com).

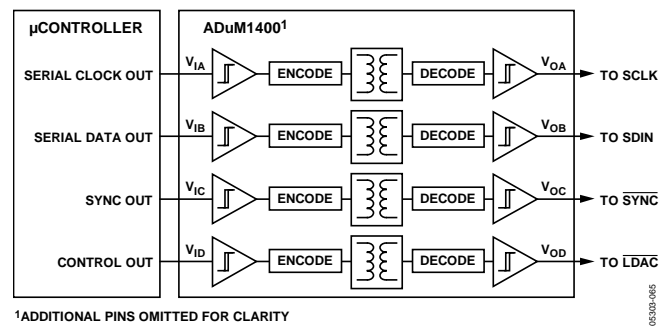
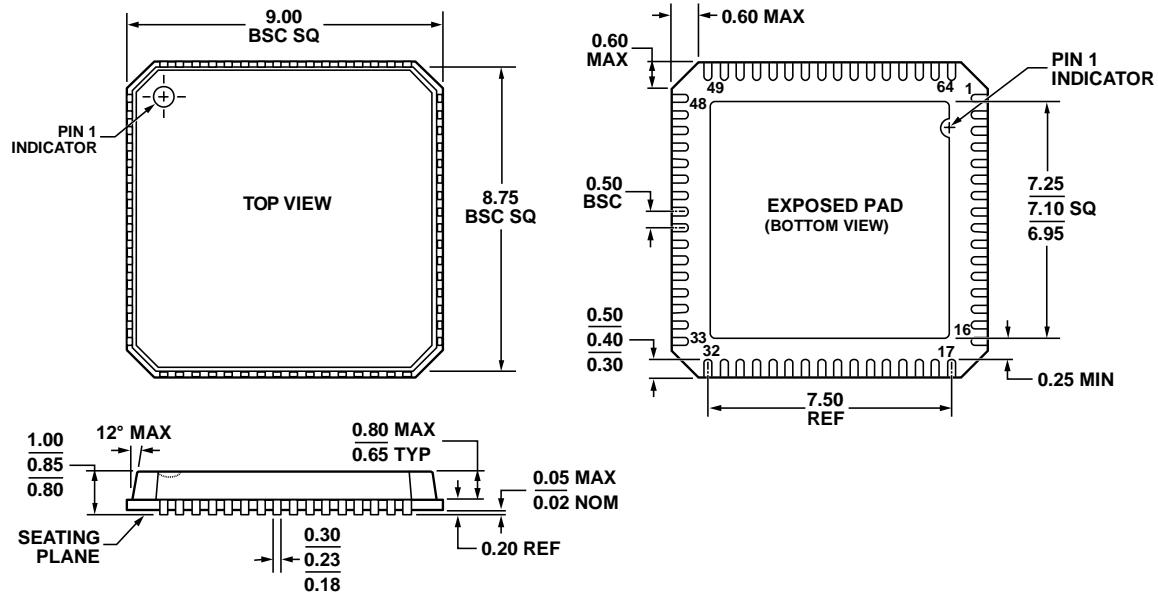

Figure 23. Isolated Interface

OUTLINE DIMENSIONS



COMPLIANT TO JEDEC STANDARDS MO-220-VMMD-4

Figure 24. 64-Lead Frame Chip Scale Package, 9x9 Quad. [LFCSP]

Dimensions shown in millimeters

051007-C

ORDERING GUIDE

Model	Resolution	Temperature Range	Package Description	Package Option
AD5755-1x	16bit	-40°C to +105°C	64-lead LFCSP	CP-64-3