

PLEASE CHECK WWW.MOLEX.COM FOR LATEST PART INFORMATION

Part Number: [0473149053](#)
Status: **Active**
Description: 1.00mm (.039") Pitch 54mm ExpressCard* Stainless Steel Ejector, Top Mount, with Push-Push Mechanism, Lead free

Documents:

[Drawing \(PDF\)](#) [RoHS Certificate of Compliance \(PDF\)](#)
[Product Specification PS-47202-001 \(PDF\)](#)

General

Product Family	Memory Card Sockets
Series	47314
Button Type	Push-Push
Comments	Slot design based on ExpressCard Standard Rev.1.0; Slot compatible with both 34mm and 54mm Cards
Component Type	Ejector (Host)
Product Name	ExpressCard*
Type	N/A

Physical

Card Detection Switch	Yes
Circuits (Loaded)	N/A
Circuits (maximum)	0
Durability (mating cycles max)	10,000
Ejector Button Side	No Ejector Button Present
Entry Angle	N/A
Keying to Mating Part	Yes
PCB Locator	No
PCB Mounting Side	Normal
PCB Retention	Yes
Packaging Type	Tray
Pitch - Mating Interface (in)	0.000 In
Pitch - Mating Interface (mm)	0.00 mm
Pitch - Term. Interface (in)	0.000 In
Pitch - Term. Interface (mm)	0.00 mm
Ports	1
Surface Mount Compatible (SMC)	Yes
Temperature Range - Operating	0°C to +55°C

Electrical

Current - Maximum per Contact	0.75A
Shielded	Yes
Voltage - Maximum	3.3V DC
Voltage Key	N/A

Solder Process Data

Duration at Max. Process Temperature (seconds)	10
Lead-free Process Capability	Reflow Capable (SMT only)
Max. Cycles at Max. Process Temperature	2
Process Temperature max. C	260

Material Info

Reference - Drawing Numbers

Packaging Specification	PK-47314-002
Product Specification	PS-47202-001
Sales Drawing	SD-47314-001

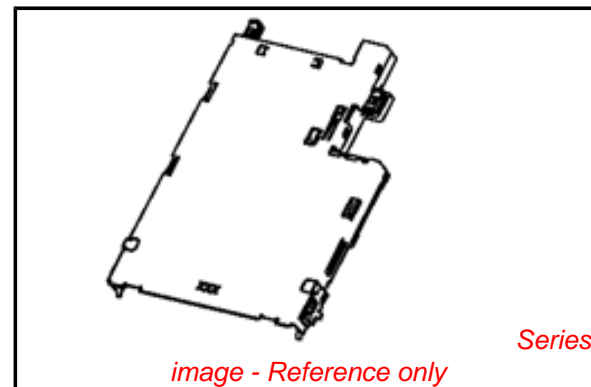

EU RoHS

ELV and RoHS Compliant
REACH SVHC Contains SVHC: No
Halogen-Free Status

China RoHS



Not Halogen-Free

Need more information on product environmental compliance?

Email productcompliance@molex.com
 For a multiple part number RoHS Certificate of Compliance, [click here](#)

Please visit the [Contact Us](#) section for any non-product compliance questions.

Search Parts in this Series

47314Series

Mates With

ExpressCard* Module

Use With

473149052 Top Mount 54mm Header

| * ExpressCard is trademark, or registered trademark of PCMCIA

This document was generated on 06/01/2010

PLEASE CHECK WWW.MOLEX.COM FOR LATEST PART INFORMATION

10 9 8 7 6 5 4 3 2 1

F

E

D

C

B

A

F

E

D

C

B

A

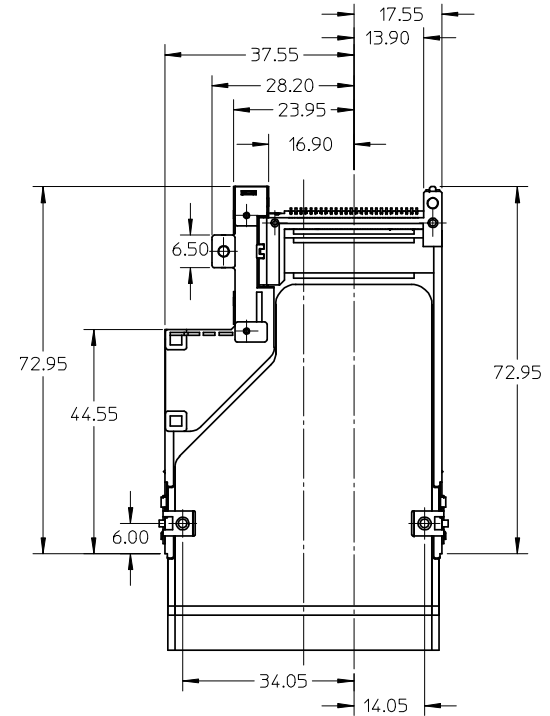
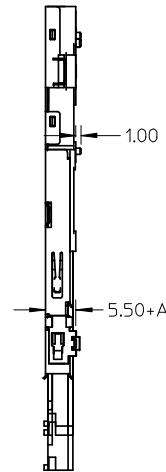
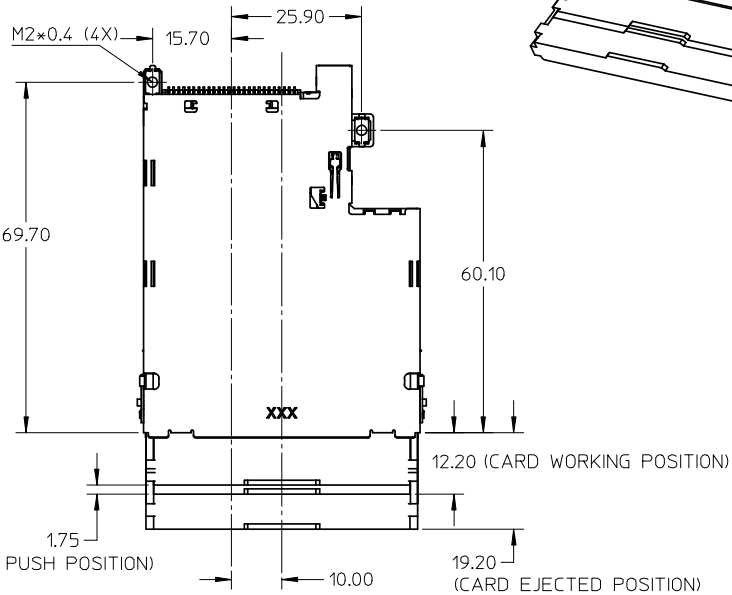
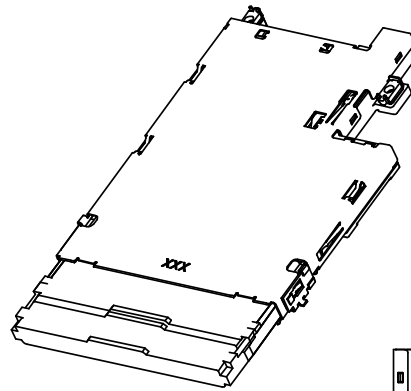
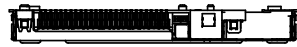

NOTES:

1. COMPONENT:

HEADER: SHEET 2

EJECTOR: SHEET 3

2. PCB LAYOUT PLEASE REFER TO SHEET 4,

3. COPLANARTY OF HEADER FOR SMT SOLDER TAILS

TO BE 0.1mm MAXIMUM,

4. PRODUCT SPECIFICATION PLEASE REFER TO PS-47202-001,

5. SCREW FASTENING TORQUE: 1.5kgf-cm MAXIMUM,

6. TRUE POSITION IS 0.15mm MAXIMUM BETWEEN SOLDER TAILS,

7. NON-REFLOW PROCESS FOR CARD CAGE.

RELEASE IEC NO: SH2008-0202 DRW: FANG05 CHKD: APPR: HWANG 2007/12/03 2007/12/04 2007/12/28	QUALITY SYMBOLS ▽=0 ◻=0	GENERAL TOLERANCES (UNLESS SPECIFIED)		DIMENSION STYLE MM ONLY		SCALE 1:1	DESIGN UNITS METRIC	THIRD ANGLE PROJECTION			
		4 PLACES ± --- ± ---	mm INCH	DRAWN BY R. BIAN	DATE 2005/08/05	TITLE EXPRESSCARD TOP MOUNT WITH PUSH-PUSH MECHANISM (CARD PUSH)					
		3 PLACES ± --- ± ---		CHECKED BY DATE		MOLEX INCORPORATED					
		2 PLACES ± 0.25 ± ---		APPROVED BY HARVEY WANG		DATE 2005/08/05	DOCUMENT NO. SD-47314-001		SHEET NO. 1 OF 4		
		1 PLACE ± 0.3 ± ---		MATERIAL NO. N/A		THIS DRAWING CONTAINS INFORMATION THAT IS PROPRIETARY TO MOLEX INCORPORATED AND SHOULD NOT BE USED WITHOUT WRITTEN PERMISSION					
		ANGULAR ± 3 °		DRAFT WHERE APPLICABLE MUST REMAIN WITHIN DIMENSIONS							

9 8 7 6 5 4 3 2 1

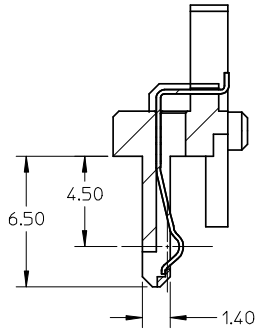
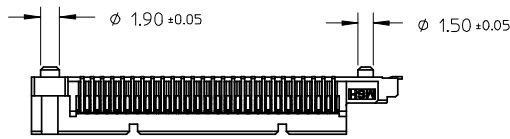
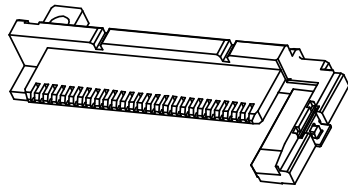

SECTION Z-Z
SCALE:4:1

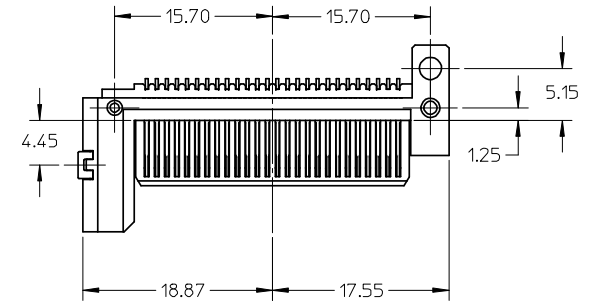
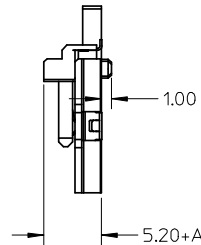
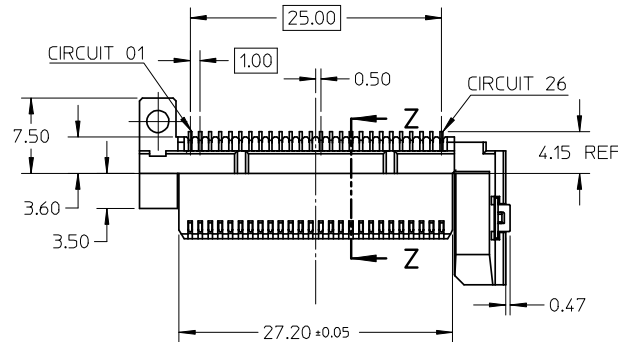

NOTES:

1. MATERIAL:

HOUSING: LIQUID CRYSTAL POLYMER, GLASS FILLED, UL94V-0, COLOUR: BLACK.
 TERMINAL: PHOSPHOR BRONZE
 FITTING NAIL: PHOSPHOR BRONZE

2. FINISH:

TERMINAL: SELECTIVE GOLD(Au) IN CONTACT AREA,
 THICKNESS: 0.3 MICROMETER MINIMUM
 SELECTIVE PURE TIN ON SOLDER TAIL AREA.
 THICKNESS: 1.5 MICROMETER MINIMUM
 UNDERPLATING: NICKEL(Ni) OVERALL

3. COPLANARITY AT SOLDER TAIL TO BE 0.1mm MAXIMUM,

4. DESIGN BASED ON EXPRESSCARD STANDARD;

5. APPLICABLE EJECTOR PLEASE SEE TABLE;

6. PRODUCT SPECIFICATION PLEASE REFER TO PS-47202-001;

7. THE PART COMPLIANT TO RoHS DIRECTIVE 2002/95/EC AND ELV 2000/53/EC.

RELEASE IEC NO: SH2008-0202 DRWNG: YANG05 2007/12/03 CHKD: 2007/12/04 APPR: HWANG 2007/12/28	QUALITY SYMBOLS ▽=0 ◻=0	GENERAL TOLERANCES (UNLESS SPECIFIED)		DIMENSION STYLE MM ONLY		SCALE NTS	DESIGN UNITS METRIC	THIRD ANGLE PROJECTION			
		4 PLACES ± --- ± --- 3 PLACES ± --- ± --- 2 PLACES ± 0.25 ± --- 1 PLACE ± 0.3 ± ---	mm INCH	DRAWN BY R. BIAN	DATE 2005/08/05	TITLE EXPRESSCARD TOP MOUNT WITH PUSH-PUSH MECHANISM (CARD PUSH)					
		ANGULAR ± 3 °		APPROVED BY HARVEY WANG	DATE 2005/08/05	MOLEX INCORPORATED					
		DRAFT WHERE APPLICABLE MUST REMAIN WITHIN DIMENSIONS		MATERIAL NO. SEE TABLE	DOCUMENT NO. SD-47314-001	SHEET NO. 2 OF 4					

47314-0052	0.50 MM	47314-9053
PART NO.	A (STAND OFF HEIGHT)	APPLICABLE EJECTOR

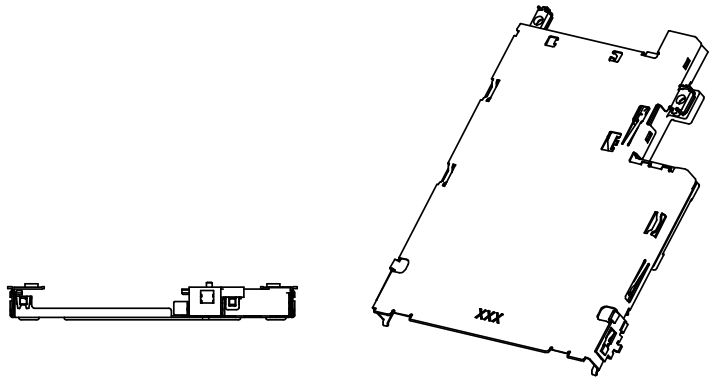

NOTES:

1. MATERIAL:

- SHELL: STAINLESS STEEL
- STAND OFF: STAINLESS STEEL
- NUT: STAINLESS STEEL
- COIL SPRING: STEEL WIRE
- CAM SLIDER: NYLON 46, GLASS FILLED, UL94V-0, COLOUR: BLACK
- SLIDER HOUSING: NYLON 46, GLASS FILLED, UL94V-0, COLOUR: BLACK
- CAM PIN: STAINLESS STEEL

- 2. THIS SLOT TO BE COMPATIBLE BOTH 34mm CARD AND 54mm CARD;
- 3. THE EJECTOR MECHANISM TO BE ASSEMBLED BASE ON 34mm CARD CENTER LINE;
- 4. APPLICABLE HEADER PLEASE SEE TABLE;
- 5. PRODUCT SPECIFICATION PLEASE REFER TO PS-47202-001;
- 6. THE PART COMPLIANT TO RoHS DIRECTIVE 2002/95/EC AND ELV 2000/53/EC.

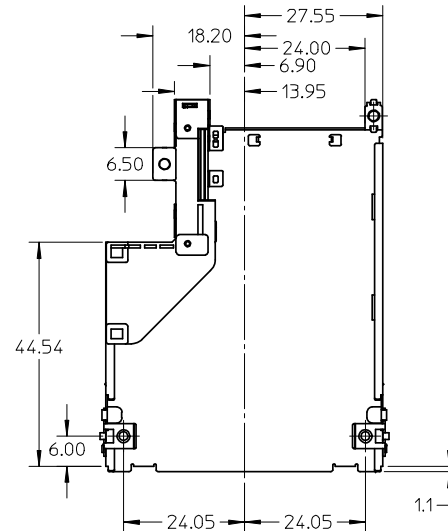
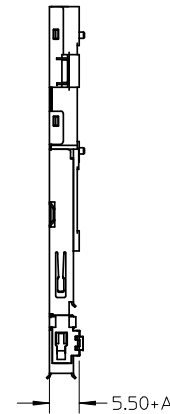
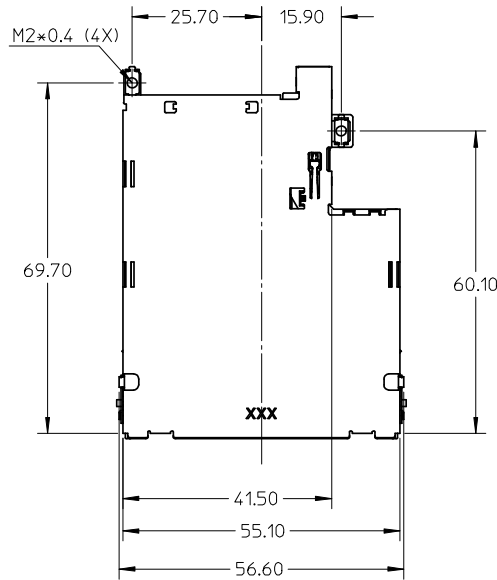

RELEASE EC NO: SHZ008-0202 DRW: F YANG05 CHKD: APPR: H WANG 2007/12/03 2007/12/04 2007/12/28	QUALITY SYMBOLS ▽=0 ◻=0	GENERAL TOLERANCES (UNLESS SPECIFIED)		DIMENSION STYLE MM ONLY		SCALE NTS	DESIGN UNITS METRIC	THIRD ANGLE PROJECTION	
			mm	INCH	DRAWN BY R. BIAN	DATE 2005/08/05	TITLE EXPRESSCARD TOP MOUNT WITH PUSH-PUSH MECHANISM (CARD PUSH)		
		4 PLACES	± ---	± ---	CHECKED BY	DATE	MOLEX INCORPORATED		
		3 PLACES	± ---	± ---	APPROVED BY HARVEY WANG		DATE 2005/08/05	DOCUMENT NO. SD-47314-001	
	2 PLACES	± 0.25	± ---	MATERIAL NO. SEE TABLE		SHEET NO. 3 OF 4			
	1 PLACE	± 0.3	± ---	DRAFT WHERE APPLICABLE MUST REMAIN WITHIN DIMENSIONS		THIS DRAWING CONTAINS INFORMATION THAT IS PROPRIETARY TO MOLEX INCORPORATED AND SHOULD NOT BE USED WITHOUT WRITTEN PERMISSION			
ANGULAR ± 3 °									

47314-9053	0.50 MM	47314-0052
PART NO.	A (STAND OFF HEIGHT)	APPLICABLE HEADER

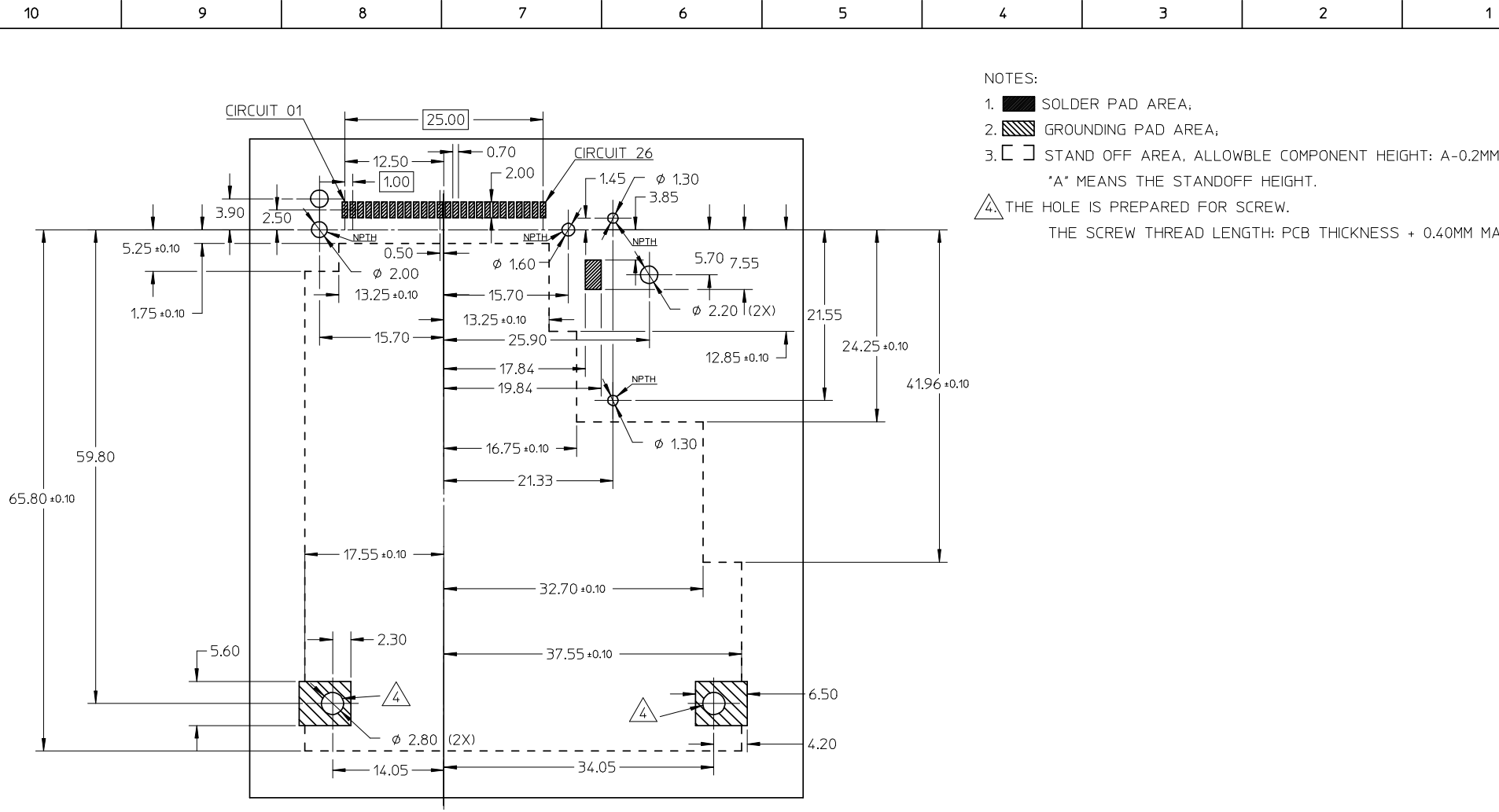

- NOTES:
1. SOLDER PAD AREA;
 2. GROUNDING PAD AREA;
 3. STAND OFF AREA, ALLOWBLE COMPONENT HEIGHT: A-0.2MM, 'A' MEANS THE STANDOFF HEIGHT.
 4. THE HOLE IS PREPARED FOR SCREW.
THE SCREW THREAD LENGTH: PCB THICKNESS + 0.40MM MAX.

RELEASE EC NO: SH2008-0202 DRWN:FYANG05 2007/12/03 CHKD: 2007/12/04 APPR:HWANG 2007/12/28	QUALITY SYMBOLS = 0 = 0	GENERAL TOLERANCES (UNLESS SPECIFIED)		DIMENSION STYLE	SCALE	DESIGN UNITS	THIRD ANGLE PROJECTION			
				MM ONLY	NTS	METRIC				
				mm	INCH	DRAWN BY	DATE	TITLE		
				4 PLACES	± ---	± ---	R. BIAN	2005/08/05	EXPRESSCARD TOP MOUNT WITH PUSH-PUSH MECHANISM (CARD PUSH)	
B REV	DESCRIPTION			3 PLACES	± ---	± ---	MOLEX INCORPORATED			
				2 PLACES	± 0.25	± ---	DOCUMENT NO.			
				1 PLACE	± 0.3	± ---	SD-47314-001			
				ANGULAR ± 3 °		APPROVED BY		DATE	SHEET NO.	
		DRAFT WHERE APPLICABLE MUST REMAIN WITHIN DIMENSIONS		HARVEY WANG		2005/08/05	4 OF 4			
				MATERIAL NO.	N/A		THIS DRAWING CONTAINS INFORMATION THAT IS PROPRIETARY TO MOLEX INCORPORATED AND SHOULD NOT BE USED WITHOUT WRITTEN PERMISSION			
				SIZE	A3					