



1A Single Chip Li-Ion and Li-Polymer Charger

General Description

The LP4076H is a complete constant-current/constant voltage linear charger for single cell lithium-ion battery. Its ESOP8 package and low external component count make the device ideally suited for portable applications. No external sense resistor is needed, and no blocking diode is required due to the internal MOSFET architecture. Thermal feedback regulates the charge current to limit the die temperature during high power operation or high ambient temperature. The charge voltage is fixed at V_{FLOAT} , and the charge current can be programmed externally by ISET pin with a single resistor.

The LP4076H automatically terminates the charge cycle when the charge current drops to 1/10 setting current value after the final float voltage is reached.

When the input supply is removed, the device automatically enters a low current state, dropping the battery drain current to less than 2µA.

Other features include charge current monitor, under voltage lockout, automatic recharge and charge status pins.

Order Information

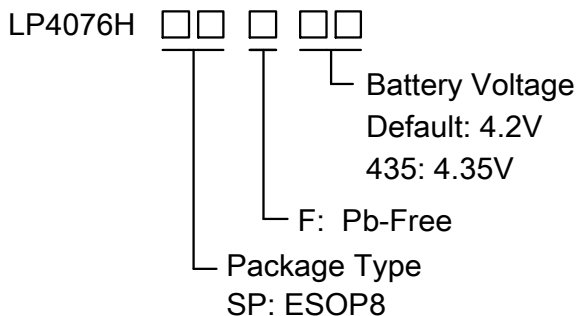

Features

- ◆ Input Voltage up to 28V
- ◆ Input Over Voltage Protection : 7V
- ◆ Short-circuit protection
- ◆ Programmable Charge Current up to 1A
- ◆ 1µA Battery Reverse Current
- ◆ Protection of Reverse Connection of Battery
- ◆ No MOSFET, Sense Resistor or Blocking Diode Required
- ◆ Constant-Current/Constant-Voltage Operation with Thermal Regulation to Maximize Charge Rate Without Risk of Overheating
- ◆ ESOP8 Package
- ◆ RoHS Compliant and 100% Lead (Pb)-Free

Applications

- ◇ Portable Media Players/Game
- ◇ Power Bank
- ◇ Bluetooth Applications
- ◇ PDA/MID

Marking Information

Device	Marking	Package	Shipping
LP4076HSPF	LPS LP4076H YWX	ESOP8	4K/REEL
LP4076HSPF -435	LPS LP4076H 435YWX	ESOP8	4K/REEL
Marking indication: Y:Production year W:Production week X:Series number			



Functional Pin Description

Package Type	Pin Configurations
ESOP8	<p style="text-align: center;">ESOP-8 TOP VIEW</p>

Pin Description

No.	NAME	DESCRIPTION
1	TS	Temperature Detection Pin. Connect this pin to GND or set the voltage at this pin under 0.3V to disable TS function
2	ISET	Charge Current Program. The charge current is programmed by connecting a 1% resistor (R_{ISET}) to ground. $I_{BAT} = \frac{1700 \times V_{ISET}}{R_{ISET}}$
3,9	GND	GND is the connection to system ground.
4	IN	IN is the input power source. Connect to a wall adapter.
5	BAT	BAT is the connection to the battery. Typically a 10 μ F tantalum capacitor is needed for stability when there is no battery attached. When a battery is attached, only a 1 μ F ceramic capacitor is required.
6	FULL	Open-Drain Charge Status Output. When the battery is charging, the FULL pin could be pulled High by an external pull high resistor. When the charge cycle is completed, the pin is pulled Low by an internal N-MOS.
7	CHRG	Open-Drain Charge Status Output. When the battery is charging, the CHRG pin is pulled low by an internal N-MOS. When the charge cycle is completed, the pin could be pulled High by an external pull high resistor.
8	EN	Charge Enable Input (active high).



Absolute Maximum Ratings ^{Note 1}

- ✧ Input Voltage to GND ----- -0.3V to 28V
- ✧ BAT Voltage GND ----- - 5V to 15V
- ✧ Other pin to GND ----- -0.3V to 6.5V
- ✧ Maximum Junction Temperature (T_J) ----- 150°C
- ✧ Maximum Soldering Temperature (at leads, 10 sec) ----- 260°C
- ✧ Operating Junction Temperature Range ----- -20°C to 85°C
- ✧ Storage Temperature ----- -65°C to 165°C

Thermal Information

- ✧ Thermal Resistance (θ_{JA}) ----- 65°C/W

ESD Susceptibility

- ✧ HBM(Human Body Model) ----- 2KV
- ✧ MM(Machine Model) ----- 200V

Note 1. Stresses beyond those listed under “Absolute Maximum Ratings” may cause permanent damage to the device. These are stress ratings only, and functional operation of the device at these or any other conditions beyond those indicated in the operational sections of the specifications is not implied. Exposure to absolute maximum rating conditions for extended periods may affect device reliability.

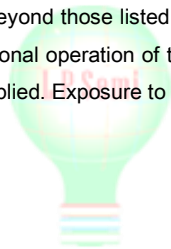



Electrical Characteristics

($T_A=25^{\circ}\text{C}$, $V_{IN}=5\text{V}$, unless otherwise noted.)

SYMBOL	PARAMETER	CONDITIONS	MIN	TYP.	MAX	UNITS
V_{IN}	Input Voltage		4.5	5	6	V
I_{IN}	Input Supply Current	$V_{BAT}=4.4\text{V}$		140	300	μA
V_{FLOAT}	Regulated Output (Float) Voltage	LP4076HSPF	4.158	4.2	4.242	V
		LP4076HSPF-435	4.307	4.35	4.393	V
V_{UVLO}	V_{IN} Under Voltage Lockout Threshold	V_{IN} Rising		3.5		V
V_{UV_HYS}	UVLO Threshold Hysteresis			140		mV
V_{OVP}	Input Voltage OVP	V_{IN} Rising	6.5	7	7.5	V
V_{OVP_HYS}	OVP Hysteresis			150		mV
I_{BAT}	BAT Pin Current	$R_{ISET}=3.4\text{K}$, Current Mode	450	500	550	mA
		$R_{ISET}=17\text{K}$, Current Mode	90	100	110	mA
		$V_{BAT}=4.2\text{V}$, $V_{IN}=\text{NC}$		-1	-2	μA
I_{TRIKL}	Trickle Charge Current	$V_{BAT}<V_{TRIKL}$, $R_{ISET}=10\text{K}$, Current Mode	13	17	22	mA
V_{TRIKL}	Trickle Charge Threshold Voltage	V_{BAT} Rising	2.4	2.6	2.75	V
V_{TRHYS}	Trickle Charge Hysteresis Voltage			150		mV
I_{TERM}	Termination Current Threshold	$I_{BAT}=500\text{mA}$	8.8	10	11.2	% I_{BAT}
		$I_{BAT}=100\text{mA}$	8.5	10	11.5	% I_{BAT}
V_{ISET}	ISET Pin Voltage	$R_{ISET}=10\text{K}$, Current Mode	0.9	1	1.1	V
V_{ASD}	$V_{IN} - V_{BAT}$ Lockout Threshold Voltage	$V_{BAT}=3.5\text{V}$, V_{IN} Rising		150		mV
I_{CHRG}	CHRG/FULL Pin Weak Pull-Down Current	$V_{CHRG}=5\text{V}$			5	μA
V_{CHRG}	CHRG/FULL Pin Output Low Voltage	$I_{CHRG}=5\text{mA}$			0.5	V
ΔV_{RECHRG}	Recharge Battery Threshold Voltage	$V_{FLOAT}-V_{RECHRG}$	100	150	200	mV
V_{TS_H}	TS high temperature threshold			30		% V_{IN}
V_{TS_L}	TS low temperature threshold			60		% V_{IN}
V_{TS_DIS}	TS function disable threshold				0.3	V
V_{EN_OFF}	EN Logic-Low Voltage Threshold				0.4	V
V_{EN_ON}	EN Logic-High Voltage Threshold		1.4			V
T_{LIM}	Junction Temperature in Constant Temperature Mode			145		$^{\circ}\text{C}$



Typical Performance Characteristics

($C_{IN}=C_{OUT}=10\mu F$, $R_{ISET}=16.5K\Omega$, unless otherwise noted)

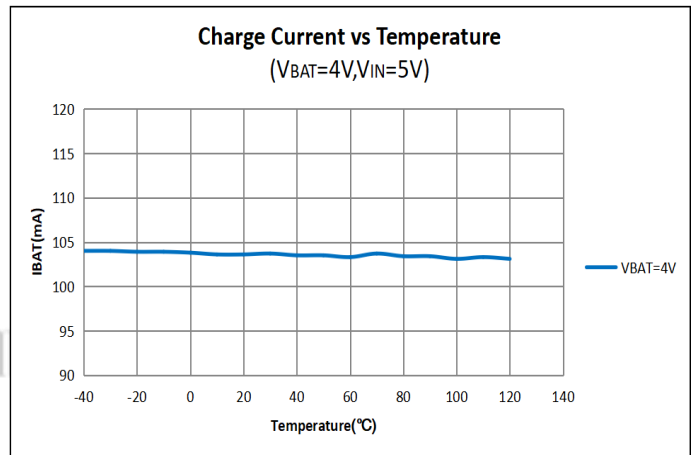
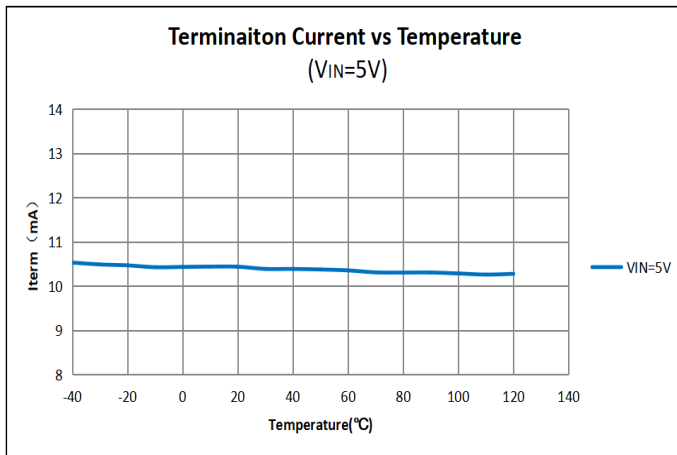
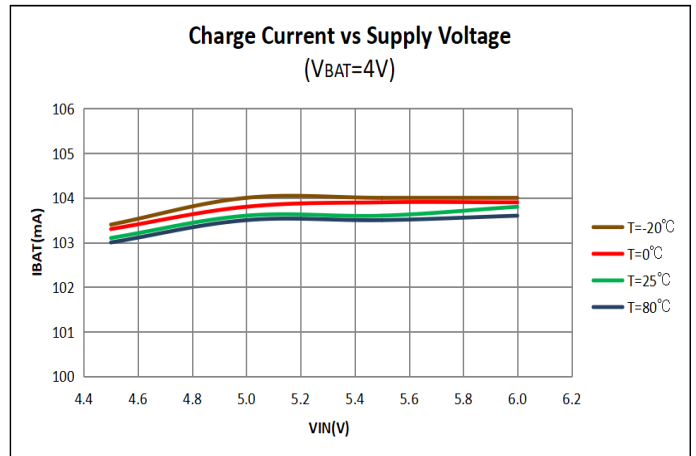
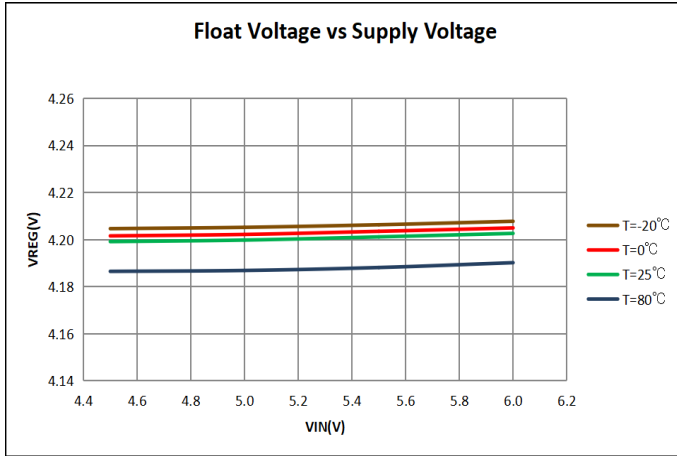



Application Information

The LP4076H has built-in input voltage surge protection as high as +28V. The charger IC will be automatically disabled when the input voltage is higher than 7V. A charge cycle begins when the voltage at the IN pin rises above the V_{UVLO} , when a battery is connected to the charger output. If the BAT pin is less than 2.6V, the charger enters trickle charge mode. In this mode, the chip supplies approximately 1/10 the ISET programmed charge current to bring the battery voltage up to a safe level for full current charging. When the BAT pin voltage rises above 2.6V, the charger enters constant-current mode(CC), where the ISET programmed charge current is supplied to the battery. When the BAT pin approaches the final float voltage, the device enters constant-voltage mode(CV) and the charge current begins to decrease, and the battery full indication is set when the charge current in the CV mode is reduced to the programmed full battery current.

Charge Termination

A charge cycle is terminated when the charge current falls to 1/10th the ISET programmed value after the final float voltage is reached. This condition is detected by using an internal, filtered comparator to monitor the ISET pin. When the ISET pin voltage falls below 100mV for longer than t_{TERM} , charging is terminated.

Charge Current Program

The charge current (I_{BAT}) is set by a resistor (R_{ISET}) connecting from the ISET pin to GND. The relationship of the charge current and the programming resistance is established by the following equations ($V_{ISET}=1V$).

$$I_{BAT} = \frac{1700 \times V_{ISET}}{R_{ISET}}$$

Automatic Recharge

Once the charge cycle is terminated, the LP4076H continuously monitors the voltage on the BAT pin. A charge cycle restarts when the battery voltage falls below 4.05V (which corresponds to approximately 80% to 90% battery capacity). This ensures that the battery is kept at or near a fully charged condition and eliminates the need for periodic charge cycle initiations.

Charge Status Indicator (CHRG/FULL)

After application of a 5V source, the input voltage rises above the V_{UVLO} and sleep thresholds ($V_{IN} > V_{BAT} + V_{ASD}$), but is less than OVP ($V_{IN} < V_{OVP}$), CHRG has two different states: strong pull-down (~5mA) and high impedance. The strong pull-down state indicates that the LP4076HA is in a charge cycle. When the charger is entered CV mode and once the charge current has reduced to the battery full charge current threshold (I_{TERM}), the CHRG pin will become high impedance.

Function	CHRG	FULL
Charging	Low	Hi-Z
Charge Finish	Hi-Z	Low

Thermal Limit

An internal thermal feedback loop reduces the I_{SET} programmed charge current if the die temperature attempts to rise above a preset value of approximately 145°C. This feature protects the chip from excessive temperature and allows the user to push the limits of the power handling capability of a given circuit board without risk of damaging the LP4076H. The charge current can be set according to typical (not worst-case) ambient temperature with the assurance that the charger will automatically reduce the current in worst-case conditions.



Battery Temperature Detection

An internal resistor divider sets the low temperature threshold (V_{TS_L}) and high temperature threshold (V_{TS_H}) at 60% of V_{IN} and 30% of V_{IN} , respectively. For a given TS thermistor, select an appropriate R_{T1} and R_{T2} to set the TS window with following equation:

$$\frac{V_{TS_L}}{V_{IN}} = \frac{R_{T2} \parallel R_{TS_COLD}}{R_{T1} + R_{T2} \parallel R_{TS_COLD}} = T_L = 60\%$$

$$\frac{V_{TS_H}}{V_{IN}} = \frac{R_{T2} \parallel R_{TS_HOT}}{R_{T1} + R_{T2} \parallel R_{TS_HOT}} = T_H = 30\%$$

Where R_{TS_HOT} is the value of the TS resistor at the upper bound of its operating temperature range, and R_{TS_COLD} is its lower bound. The two resistors R_{T1} and R_{T2} determine the upper and lower temperature limits independently. This flexibility allows the IC to operate with most TS resistors for different temperature range requirements. Calculate R_{T1} and R_{T2} with following equation:

$$R_{T1} = \frac{R_{TS_HOT} \times R_{TS_COLD} \times (T_L - T_H)}{T_H \times T_L \times (R_{TS_COLD} - R_{TS_HOT})}$$

$$R_{T2} = \frac{R_{TS_HOT} \times R_{TS_COLD} \times (T_L - T_H)}{(1 - T_L) \times T_H \times R_{TS_COLD} - (1 - T_H) \times T_L \times R_{TS_HOT}}$$

Connect this pin to GND or set the voltage at this pin under 0.3V if you want to disable TS function.





Packaging Information

ESOP8

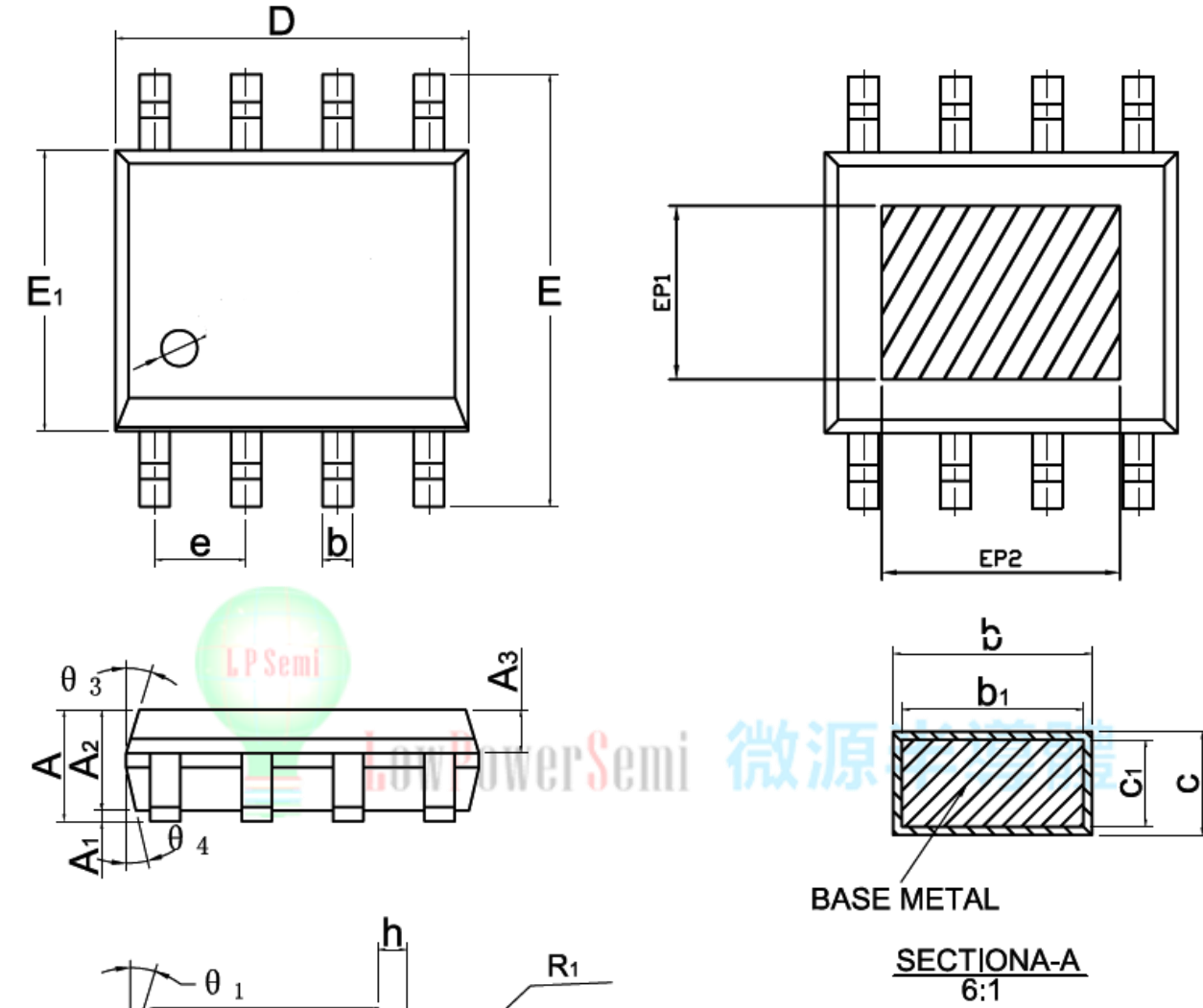

DIMENSIONS IN MULLIMETERS

SYMBOL	MIN	NOM	MAX	SYMBOL	MIN	NOM	MAX
A	1.35	1.55	1.75	L ₁	1.04REF		
A ₁	0.00	—	0.10	L ₂	0.25BSC		
A ₂	1.25	1.40	1.65	R	0.07	—	—
A ₃	0.50	0.60	0.70	R ₁	0.07	—	—
b	0.39	—	0.49	h	0.3	0.4	0.5
b ₁	0.28	—	0.48		0°	—	8°
c	0.10	—	0.25	θ ₁	11°	17°	19°
c ₁	0.10	—	0.23	θ ₂	11°	13°	15°
D	4.80	4.90	5.00	θ ₃	15°	17°	19°
E	5.80	6.00	6.20	θ ₄	11°	13°	15°
E ₁	3.80	3.90	4.00	EP1	2.40	—	—
e	1.27BSC			EP2	3.30	—	—