

SUPER  [®]

X9SAE
X9SAE-V

USER'S MANUAL

Revision 1.0b

The information in this User's Manual has been carefully reviewed and is believed to be accurate. The vendor assumes no responsibility for any inaccuracies that may be contained in this document, makes no commitment to update or to keep current the information in this manual, or to notify any person or organization of the updates. **Please Note: For the most up-to-date version of this manual, please see our web site at www.supermicro.com.**

Super Micro Computer, Inc. ("Supermicro") reserves the right to make changes to the product described in this manual at any time and without notice. This product, including software and documentation, is the property of Supermicro and/or its licensors, and is supplied only under a license. Any use or reproduction of this product is not allowed, except as expressly permitted by the terms of said license.

IN NO EVENT WILL SUPER MICRO COMPUTER, INC. BE LIABLE FOR DIRECT, INDIRECT, SPECIAL, INCIDENTAL, SPECULATIVE OR CONSEQUENTIAL DAMAGES ARISING FROM THE USE OR INABILITY TO USE THIS PRODUCT OR DOCUMENTATION, EVEN IF ADVISED OF THE POSSIBILITY OF SUCH DAMAGES. IN PARTICULAR, SUPER MICRO COMPUTER, INC. SHALL NOT HAVE LIABILITY FOR ANY HARDWARE, SOFTWARE, OR DATA STORED OR USED WITH THE PRODUCT, INCLUDING THE COSTS OF REPAIRING, REPLACING, INTEGRATING, INSTALLING OR RECOVERING SUCH HARDWARE, SOFTWARE, OR DATA.

Any disputes arising between manufacturer and customer shall be governed by the laws of Santa Clara County in the State of California, USA. The State of California, County of Santa Clara shall be the exclusive venue for the resolution of any such disputes. Supermicro's total liability for all claims will not exceed the price paid for the hardware product.

FCC Statement: This equipment has been tested and found to comply with the limits for a Class B digital device pursuant to Part 15 of the FCC Rules. These limits are designed to provide reasonable protection against harmful interference in a residential installation. This equipment generates, uses, and can radiate radio frequency energy and, if not installed and used in accordance with the manufacturer's instruction manual, may cause interference with radio communications. However, there is no guarantee that interference will not occur in a particular installation. If this equipment does cause harmful interference to radio or television reception, which can be determined by turning the equipment off and on, you are encouraged to try to correct the interference by one or more of the following measures:

- Reorient or relocate the receiving antenna.
- Increase the separation between the equipment and the receiver.
- Connect the equipment into an outlet on a circuit different from that to which the receiver is connected.
- Consult the dealer or an experienced radio/television technician for help.

California Best Management Practices Regulations for Perchlorate Materials: This Perchlorate warning applies only to products containing CR (Manganese Dioxide) Lithium coin cells. "Perchlorate Material-special handling may apply. See www.dtsc.ca.gov/hazardouswaste/perchlorate".

WARNING: Handling of lead solder materials used in this product may expose you to lead, a chemical known to the State of California to cause birth defects and other reproductive harm.

Manual Revision 1.0b

Release Date: June 21, 2016

Unless you request and receive written permission from Super Micro Computer, Inc., you may not copy any part of this document. Information in this document is subject to change without notice. Other products and companies referred to herein are trademarks or registered trademarks of their respective companies or mark holders.

Copyright © 2016 by Super Micro Computer, Inc. All rights reserved.

Printed in the United States of America

Preface

This manual is written for system integrators, IT technicians and knowledgeable end users. It provides information for the installation and use of the **SUPER** X9SAE Motherboard Series.

About This Motherboard

The **SUPER** X9SAE Motherboard Series supports a single Intel® Xeon™ E3-1200 v2 series, Xeon™ E3-1200 series, Pentium™, and Celeron™ processor in an LGA 1155 socket. With the Intel® C216 chipset built in, the X9SAE Motherboard Series offers substantial enhancement in system performance for the entry-level workstation or PC gaming platform.

Please refer to our website (<http://www.supermicro.com/products/>) for processor and memory support updates. This product is intended to be installed and serviced by professional technicians.

Manual Organization

Chapter 1 describes the features, specifications and performance of the motherboard.

Chapter 2 provides hardware installation instructions. Read this chapter when installing the processor, memory modules and other hardware components into the system. If you encounter any problems, see **Chapter 3**, which describes troubleshooting procedures for video, memory and system setup stored in the CMOS.

Chapter 4 includes an introduction to the BIOS, and provides detailed information on running the CMOS Setup utility.

Appendix A provides BIOS Error Beep Codes.

Appendix B lists software program installation instructions.

Appendix C contains UEFI BIOS Recovery instructions.

Conventions Used in the Manual:

Special attention should be given to the following symbols for proper installation and to prevent damage done to the components or injury to yourself:



Danger/ Caution: Instructions to be strictly followed to prevent catastrophic system failure or to avoid bodily injury



Warning: Critical information to prevent damage to the components or data loss.



Important: Important information given to ensure proper system installation or to relay safety precautions.



Note: Additional Information given to differentiate various models or provides information for correct system setup.

Contacting Supermicro

Headquarters

Address: Super Micro Computer, Inc.
980 Rock Ave.
San Jose, CA 95131 U.S.A.

Tel: +1 (408) 503-8000

Fax: +1 (408) 503-8008

Email: marketing@supermicro.com (General Information)
support@supermicro.com (Technical Support)

Website: www.supermicro.com

Europe

Address: Super Micro Computer B.V.
Het Sterrenbeeld 28, 5215 ML
's-Hertogenbosch, The Netherlands

Tel: +31 (0) 73-6400390

Fax: +31 (0) 73-6416525

Email: sales@supermicro.nl (General Information)
support@supermicro.nl (Technical Support)
rma@supermicro.nl (Customer Support)

Website: www.supermicro.nl

Asia-Pacific

Address: Super Micro Computer, Inc.
3F, No. 150, Jian 1st Rd.
Zhonghe Dist., New Taipei City 235
Taiwan (R.O.C)

Tel: +886-(2) 8226-3990

Fax: +886-(2) 8226-3992

Email: support@supermicro.com.tw

Website: www.supermicro.com.tw

Table of Contents

Preface

About This Motherboard.....	iii
Manual Organization	iii
Conventions Used in the Manual:.....	iv
Contacting Supermicro.....	v

Chapter 1 Introduction

1-1 Overview	1-1
Checklist.....	1-1
Motherboard Features.....	1-7
1-2 Chipset Overview	1-10
Intel C216 Chipset Features.....	1-10
1-3 Special Features	1-11
Recovery from AC Power Loss.....	1-11
1-4 PC Health Monitoring.....	1-11
Fan Status Monitor with Firmware Control	1-11
Environmental Temperature Control	1-11
System Resource Alert	1-12
1-5 ACPI Features.....	1-12
Slow Blinking LED for Suspend-State Indicator	1-12
1-6 Power Supply.....	1-12
1-7 Super I/O.....	1-13

Chapter 2 Installation

2-1 Static-Sensitive Devices.....	2-1
Precautions	2-1
Unpacking	2-1
2-2 Processor and Heatsink Installation.....	2-2
Installing the LGA1155 Processor	2-2
Installing an Active CPU Heatsink with Fan	2-5
Removing the Heatsink.....	2-7
2-3 Installing DDR3 Memory.....	2-8
DIMM Installation	2-8
Removing Memory Modules	2-8
Memory Support.....	2-9
Memory Population Guidelines	2-9
2-4 Motherboard Installation.....	2-11
Tools Needed	2-11

	Location of Mounting Holes	2-11
	Installing the Motherboard	2-12
2-5	Connectors/IO Ports.....	2-13
	Backplane I/O Panel	2-13
	ATX PS/2 Keyboard/Mouse Ports	2-14
	Universal Serial Bus (USB).....	2-15
	Ethernet Ports	2-16
	Back Panel High Definition Audio (HD Audio)	2-16
	Front Accessible Audio Header	2-17
	HDMI Ports.....	2-18
	VGA Port	2-18
	Serial Port (COM1).....	2-18
	Front Control Panel.....	2-19
	Front Control Panel Pin Definitions.....	2-20
	Power LED	2-20
	HDD LED.....	2-20
	NIC1/NIC2 (LAN1/LAN2).....	2-21
	Overheat (OH)/Fan Fail.....	2-21
	Reset Button	2-22
	Power Button	2-22
2-6	Connecting Cables.....	2-23
	ATX Main PWR & CPU PWR Connectors (JPW1 & JPW2)	2-23
	Fan Headers (FAN 1 ~ FAN 4, FAN A).....	2-24
	Chassis Intrusion (JL1)	2-24
	Internal Buzzer (SPK1)	2-25
	Speaker (JD1)	2-25
	Onboard Power LED (JLED).....	2-26
	Serial Ports (COM1 ~ COM2).....	2-26
	DOM PWR Connector (JSD1).....	2-27
	Legacy Wake-On-LAN (JSTBY).....	2-27
	SPDIF IN / SPDIF OUT (JSPDIF_IN/JSPDIF_OUT)	2-28
	TPM Header (JTPM1).....	2-28
	T-SGPIO Headers (T-SGPIO1/2).....	2-29
2-7	Jumper Settings	2-30
	Explanation of Jumpers	2-30
	LAN Port Enable/Disable (JPL1/JPL2).....	2-30
	CMOS Clear (JBT1).....	2-31
	PCI Slot SMB Enable (I ² C1/I ² C2).....	2-31

	ME Manufacturing Mode (JPME2).....	2-32
	ME Recovery Mode (JPME1).....	2-32
	Audio Enable (JPAC1).....	2-33
	Watch Dog Timer Reset (JWD1).....	2-33
	USB Wake-Up (JPUSB1/JUSB2).....	2-34
2-8	Onboard Indicators.....	2-35
	LAN 1/LAN 2 LEDs	2-35
	Onboard Power LED (LED1)	2-35
2-9	SATA Connections.....	2-36
	SATA Connections (I-SATA0~I-SATA5).....	2-36

Chapter 3 Troubleshooting

3-1	Troubleshooting Procedures	3-1
	Before Power On	3-1
	No Power	3-1
	No Video	3-2
	Memory Errors	3-2
	Losing the System's Setup Configuration.....	3-2
3-2	Technical Support Procedures	3-3
3-3	Frequently Asked Questions	3-4
3-4	Battery Removal and Installation	3-6
	Battery Removal.....	3-6
	Proper Battery Disposal	3-6
	Battery Installation.....	3-7
3-5	Returning Merchandise for Service.....	3-7

Chapter 4 BIOS

4-1	Introduction.....	4-1
	Starting BIOS Setup Utility.....	4-1
	How To Change the Configuration Data	4-1
	How to Start the Setup Utility	4-2
4-2	Main Setup.....	4-2
	System Overview: The following BIOS information will be displayed:.....	4-3
	System Time/System Date	4-3
	Supermicro X9SAE	4-3
	Version.....	4-3
	Build Date.....	4-3
	Processor	4-3
	Speed	4-3
	Physical Count	4-3

	Logical Count	4-3
	System Memory	4-3
	Size.....	4-3
4-3	Advanced Setup Configurations.....	4-4
	▶ Boot Feature.....	4-4
	Quiet Boot	4-4
	AddOn ROM Display Mode.....	4-4
	Bootup Num-Lock.....	4-4
	Wait For 'F1' If Error.....	4-4
	Interrupt 19 Capture	4-4
	▶ Power Configuration.....	4-5
	Watch Dog Function.....	4-5
	Power Button Function.....	4-5
	Restore on AC Power Loss.....	4-5
	Deep Sx Power Policies.....	4-5
	▶ Processor & Clock Options	4-5
	Clock Spread Spectrum	4-5
	Hardware Prefetcher (Available when supported by the CPU)	4-6
	Adjacent Cache Line Prefetch (Available when supported by the CPU)...	4-6
	Intel® Virtualization Technology (Available when supported by the CPU) ..	4-6
	Execute-Disable Bit Capability (Available when supported by the OS and the CPU).....	4-6
	Intel® AES-NI	4-6
	Active Processor Cores.....	4-6
	Power Technology	4-6
	▶ Turbo Boost Technology (Available when Intel® EIST technology is Enabled)	
4-7		
	Turbo Mode	4-7
	Factory Long Duration Power Limit.....	4-7
	Long Duration Power Limit.....	4-7
	Factory Long Duration Maintained	4-7
	Long Duration Maintained	4-7
	Recommended Short Duration Power Limit.....	4-7
	Short duration power limit	4-7
	Chipset Configuration.....	4-8
	Memory Frequency	4-8
	VT-d.....	4-8
	Active State Power Management.....	4-8
	PCIe Maximum Read Request	4-8

PCI Express Port.....	4-8
PCI Express Port - Gen X.....	4-9
De-emphasis Control.....	4-9
Aperture Size.....	4-9
DVMT Pre-Allocated.....	4-9
DVMT Total Gfx Mem.....	4-9
Gfx Low Power Mode.....	4-9
Graphics Performance Analyzers.....	4-9
RC6 (Render Standby).....	4-9
RC6+ (Deep RC6).....	4-10
GT OverClocking Support.....	4-10
USB Functions.....	4-10
USB 3.0 Functions.....	4-10
Legacy USB Support.....	4-10
Port 60/64 Emulation.....	4-10
BIOS EHCI Hand-Off.....	4-10
XHCI Hand-off.....	4-10
Azalia HD Audio (available if JPAC1 jumper is enabled).....	4-11
Frontside Audio Mode (available if Azalia HD Audio is enabled).....	4-11
▶ IDE/SATA Configuration.....	4-11
SATA Mode.....	4-11
▶ PCIe/PCI/PnP Configuration.....	4-12
PCI Latency Timer.....	4-12
Above 4G Decoding.....	4-12
PERR# Generation.....	4-12
SERR# Generation.....	4-12
PCI-E Slot 5 OPROM.....	4-12
Onboard LAN Option ROM Select.....	4-13
Onboard LAN1/LAN2 Option ROM.....	4-13
▶ Super IO Configuration.....	4-13
Serial Port 1 / Serial Port 2.....	4-13
Serial Port 1 / Serial Port 2 Settings.....	4-13
▶ Serial Port Console Redirection.....	4-14
▶ Hardware Health Configuration.....	4-15
Fan Speed Control Mode.....	4-15
CPU Temperature.....	4-15
System Temperature / Peripheral Temperature / PCH Temperature.....	4-15
Fan 1 ~ Fan 4, Fan A Reading.....	4-16
VCORE, 12V, VDIMM, 5VCC, VTT, AVCC, 3.3VCC, VSB, VBAT.....	4-16

	▶ACPI Settings	4-16
	High Precision Event Timers	4-16
	Suspend Mode	4-16
	WHEA Support	4-16
	▶Trusted Computing Configuration	4-16
	TPM Support	4-16
	▶Intel TXT(LT) Configuration	4-16
	Secure Mode Extensions (SMX)	4-16
	Intel TXT (LT) Support	4-17
	▶PCH-FW Configuration	4-17
	▶Firmware Update Configuration	4-17
	▶AMT Configuration	4-17
	Intel AMT	4-17
	BIOS Hotkey Pressed	4-17
	MEBx Selection Screen	4-17
	Hide Un-configure ME Confirmation Prompt	4-17
	MEBx Debug Message Output	4-17
	Un-Configure ME	4-17
	AMT Wait Timer	4-17
	Disable ME	4-18
	ASF	4-18
	Activate Remote Assistance Process	4-18
	USB Configure	4-18
	PET Progress	4-18
	Watch Dog Timer	4-18
	▶Network Stack	4-18
4-4	Event Logs	4-19
	▶Change SmBIOS Event Log Settings	4-19
	Smbios Event Log	4-19
	Erase Event Log	4-19
	When Log is Full	4-19
	Log System Boot Event	4-19
	MECI	4-19
	METW	4-20
	View SmBIOS Event Log	4-20
4-5	Boot Settings	4-21
	Setup Prompt Timeout	4-21
	Retry Boot Devices	4-21
	Boot Option Filter	4-21

	Boot Option #1, #2, #3,	4-21
	Network Device BBS Priorities, CD/DVD ROM Drive BBS Priorities, Hard Drive BBS Priorities,.....	4-21
4-6	Security Settings	4-22
	Password Check	4-22
	Administrator Password	4-22
	User Password:	4-22
4-7	Save & Exit Options	4-23
	Discard Changes and Exit	4-23
	Save Changes and Reset	4-23
	Discard Changes.....	4-23
	Restore Defaults.....	4-23
	Save As User Defaults	4-23
	Restore User Defaults	4-24
	Boot Override	4-24

Appendix A BIOS Error Beep Codes

A-1	BIOS Error Beep Codes	A-1
-----	-----------------------------	-----

Appendix B Software Installation Instructions

B-1	Installing Drivers.....	B-1
B-2	Configuring SuperDoctor [®] III.....	B-2

Appendix C UEFI BIOS Recovery Instructions

C-1	An Overview to the UEFI BIOS	C-1
C-2	How to Recover the UEFI BIOS Image (-the Main BIOS Block).....	C-1
C-3	To Recover the Boot Sector Using a USB-Attached Device	C-1

Chapter 1

Introduction

1-1 Overview

Checklist

Congratulations on purchasing your computer motherboard from an acknowledged leader in the industry. Supermicro boards are designed with the utmost attention to detail to provide you with the highest standards in quality and performance.

Please check that the following items have all been included with your motherboard. If anything listed here is damaged or missing, contact your retailer.

The following items are included in the retail box.

- One (1) Supermicro Motherboard
- Two (2) SATA cables
- One (1) I/O shield

Software utilities for this motherboard are available for download at

<http://www.supermicro.com>.

SUPER X9SAE Motherboard Image

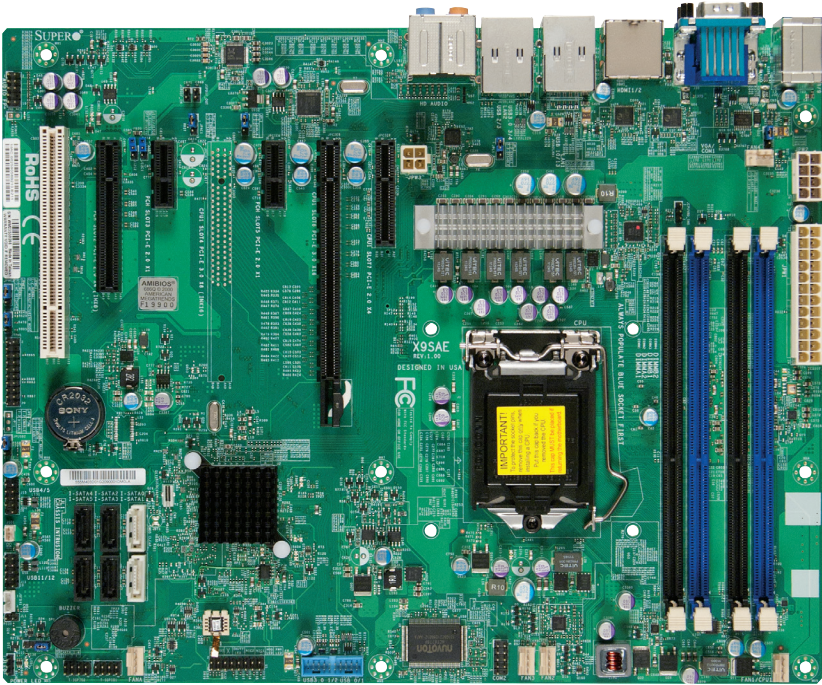

Note: All graphics shown in this manual were based upon the latest PCB Revision available at the time of publishing of the manual. The motherboard you've received may or may not look exactly the same as the graphics shown in this manual.

X9SAE Motherboard Layout

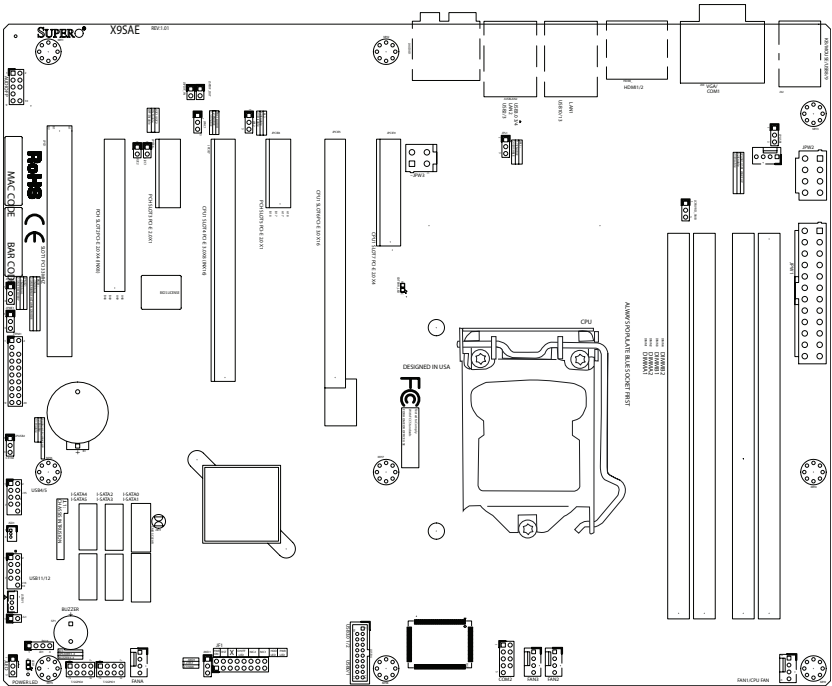

Important Notes to the User

- See Chapter 2 for detailed information on jumpers, I/O ports and JF1 front panel connections.
- "■" indicates the location of "Pin 1".
- Jumpers not indicated are for testing only.

X9SAE Quick Reference

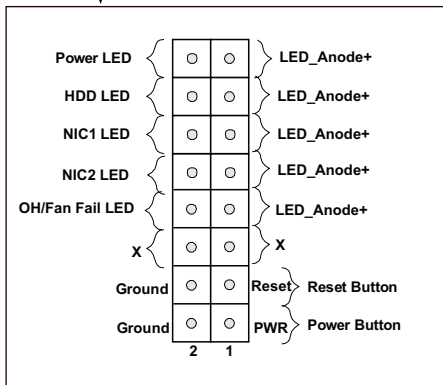
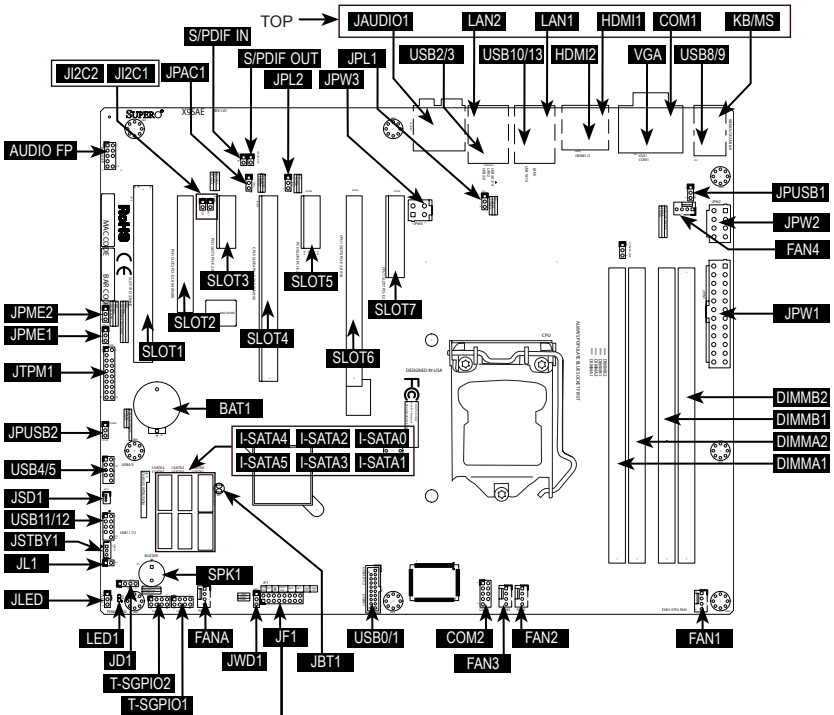

Back Panel

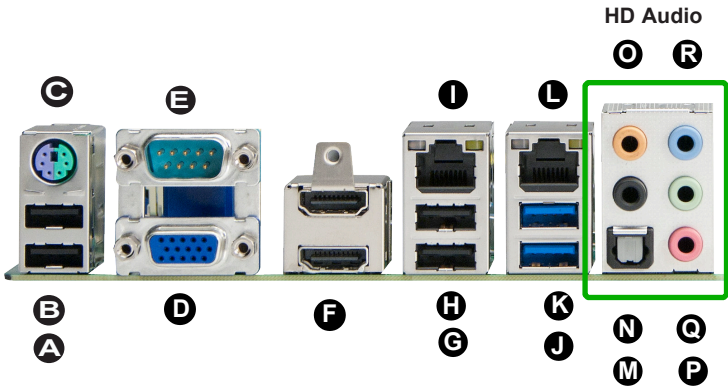

Backplane I/O Panel		
A. USB 2.0 Port 9	G. USB 2.0 Port 13	M. SPDIF Out
B. USB 2.0 Port 8	H. USB 2.0 Port 10	N. Surround Out
C. Keyboard/Mouse	I. Gb LAN Port 1	O. Center/LFE Out
D. VGA Port	J. USB 2.0 Port 3**	P. Mic In
E. Serial Port (COM1)	K. USB 2.0 Port 2*	Q. Line Out
F. HDMI1/HDMI2 Ports	L. Gb LAN Port 2	R. Line In

*USB 3.0 Port 3 **USB 3.0 Port 4

HD Audio

X9SAE Motherboard Series Jumpers		
Jumper	Description	Default
JBT1	CMOS Clear	N/A
J ¹ C1/J ¹ C2	SMB to PCI Slots	Off (Disabled)
JPAC1	Audio Enable	Pins 1-2 (Enabled)
JPL1/JPL2	LAN1/LAN2 Disable/Enable	Pins 1-2 (Enabled)
JPME1	Intel ME Recovery Mode	Pins 1-2 (Disabled)
JPME2	Intel ME Manufacturing Mode	Pins 1-2 (Disabled)
JPUSB1/JPUSB2	USB Wake-Up (JPUSB1: Back panel, JPUSB2: Headers)	Pins 1-2 (Enabled)
JWD1	Watch Dog Timer Reset	Pins 1-2 (Reset)

X9SAE Motherboard Series LED Indicators			
LED	Description	Color/State	Status
LED1	Onboard Standby PWR LED	Green: Solid on	Power On

X9SAE Motherboard Series Headers/Connectors	
Connector	Description
AUDIO FP	Front Panel Audio Header
JAUDIO	High-Definition Audio Connectors (on the I/O back panel)
BAT1, SPK1	Onboard Battery, Internal Speaker/Buzzer
COM1, COM2	COM1 Port (Back Panel), COM2 Serial Port Header
FAN1~FAN4, FANA	System/CPU Fan Headers (FAN1: CPU Fan, FANA: I/O Cards)
JD1	Speaker/buzzer (Pins 1-2: Buzzer, Pins 1~4: External Speaker)
JF1	Front Panel Control Header
JLED	Power LED Indicator Header
JPW1	24-pin ATX Main Power Connector (Required)
JPW2	+12V 8-pin CPU power Connector (Required)
JPW3	+12V 4-pin Auxilliary power Connector
KB/MS	Keyboard/Mouse Connectors
LAN1/LAN2	Gigabit (RJ45) Ports (LAN1/2)
S/PDIF IN, S/PDIF OUT	SPDIF (Sony/Philips Digital Interface) In/Out Headers
JSD1	SATA DOM (Device_On_Module) Power Connector
SLOT1	PCI 33MHz Slot
SLOT2	PCI-E 2.0 x4 (in x8) Slot
SLOT3, SLOT5	PCI-E 2.0 x1 Slot
SLOT4	X9SAE-V: PCI-E 3.0 x8 (in x16)
SLOT6	PCI-E 3.0 x16 Slot (X9SAE-V: PCI-E 3.0 x8 (in x16) Slot)
SLOT7	PCI-E 2.0 x4 Slot
HDMI1, HDMI2	Back panel HDMI Ports
JL1	Chassis Intrusion Header
JSTBY	Legacy Wake on LAN Header
JTPM1	TPM (Trusted Platform Module) 1.2 Header
I-SATA0 / I-SATA1	Serial ATA (SATA 3.0) Ports 0/1 (6Gb/sec)
I-SATA 2~I-SATA5	Serial ATA (SATA 2.0) Ports 2~5 (3Gb/sec)
USB 8/9, 10/13	Back panel USB 2.0 8/9, 10/13
USB 2/3	Back panel USB 2.0 2/3 (USB 3.0 3/4)
USB 0/1	Front Panel Accessible USB 2.0 Headers 0/1 (USB 3.0 1/2)
USB 4/5, 11/12	Front Panel Accessible USB 2.0 Headers 4/5, 11/12
T-SGPIO1, T-SGPIO2	Serial General Purpose I/O Headers (for SATA)
VGA	Back panel VGA Port

Motherboard Features

CPU	Intel® Xeon™ E3-1200 v2 series, Xeon™ E3-1200 series, Pentium™, and Celeron™ processor in an LGA 1155 socket	
Memory	Four (4) slots support up to 32 GB of unbuffered, ECC DDR3 UDIMM memory (1600/1333/1066 MHz)	
	Supports dual-channel memory bus	
	DIMM sizes	
	UDIMM	2 GB, 4GB, and 8GB
Chipset	Intel® C216	
Expansion Slots	Two (2) PCI Express 2.0 x1 slot	
	One (1) PCI Express 2.0 x4 slot	
	One (1) PCI Express 2.0 x4 (in x8) slot	
	One (1) PCI Express 3.0 x16 slot (X9SAE only)	
	Two (2) PCI Express 3.0 x8 in x 16 slot (X9SAE-V only)	
	One (1) PCI 33 MHz slots (5 Volts)	
Network Connections	Two (2) Gigabit Ethernet Controllers: LAN1: Intel® 82579LM LAN2: Intel® 82574L	
	Two (2) RJ-45 Rear I/O Panel Connectors with Link and Activity LEDs	
I/O Devices	SATA Connections	
	SATA 3.0 (6Gb/s)	Two (2) SATA 0~1
		RAID 0, 1
	SATA 2.0 (3Gb/s)	Four (4) I-SATA 2~5
		RAID 0, 1, 5, 10 (MS Windows®)
		RAID 0, 1, 10 (Linux)
	Disk-on-Module (DOM) header	
	USB Devices	
	Four (4) USB 2.0 ports and two (2) USB 3.0 ports on the rear I/O panel	
	Six (6) Front Accessible USB 2.0 ports on three headers, and two (2) Front Accessible USB 3.0 ports on one header	
	Keyboard/Mouse	
	One shared PS/2 Keyboard/Mouse port on the I/O backpanel	
	Serial (COM) Ports	
One (1) Front accessible Serial Port header (COM2)		
One (1) Serial Port on the back panel (COM1)		

	<p>Audio</p> <p>Five (5) Female Mini Jacks for High Definition Audio on the Back Panel</p> <p>Front Panel Audio Header</p> <p>One (1) S/PDIF Optical Out on the back panel</p> <p>S/PDIF In and S/PDIF Out Headers</p> <p>Video</p> <p>One VGA (D-Sub), two (2) HDMI ports on the back panel</p> <p>AMD® Crossfire™ X support</p>
BIOS	<p>128 Mb AMI BIOS® SPI Flash BIOS</p> <p>Play and Plug (PnP0, DMI 2.3, PCI 2.2, ACPI 1.0/2.0, USB Keyboard and SMBIOS 2.3</p>
Power Configuration	<p>ACPI/APM Power Management</p> <p>Main Switch Override Mechanism</p> <p>Keyboard Wake-up from Soft-Off</p> <p>Power-on mode for AC power recovery</p>
PC Health Monitoring	<p>CPU Monitoring</p> <p>Onboard voltage monitors for 1.8V, +3.3V, +5V, +/-12V, +3.3V Stdby, +5V Stdby, VBAT, HT, Memory, Chipset</p> <p>CPU 4+2 phase switching voltage regulator</p> <p>CPU/System overheat LED</p> <p>CPU Thermal Trip support</p> <p>Thermal Monitor 2 (TM2) support</p> <p>Fan Control</p> <p>Fan status monitoring with firmware 4-pin (Pulse Width Modulation) fan speed control</p> <p>Low noise fan speed control</p>
System Management	<p>PECI (Platform Environment Configuration Interface) 2.0 support</p> <p>System resource alert via SuperDoctor® III</p> <p>SuperDoctor® III, Watch Dog, NMI</p> <p>Chassis Intrusion header and detection, TPM 1.2 header</p>
CD Utilities	<p>BIOS flash upgrade utility</p> <p>Drivers and software for Intel® C216 chipset utilities</p>
Other	<p>ROHS 6/6 (Full Compliance, Lead Free)</p>
Dimensions	<p>ATX form factor (12.0" x 9.6")</p>

X9SAE Motherboard Series Block Diagram

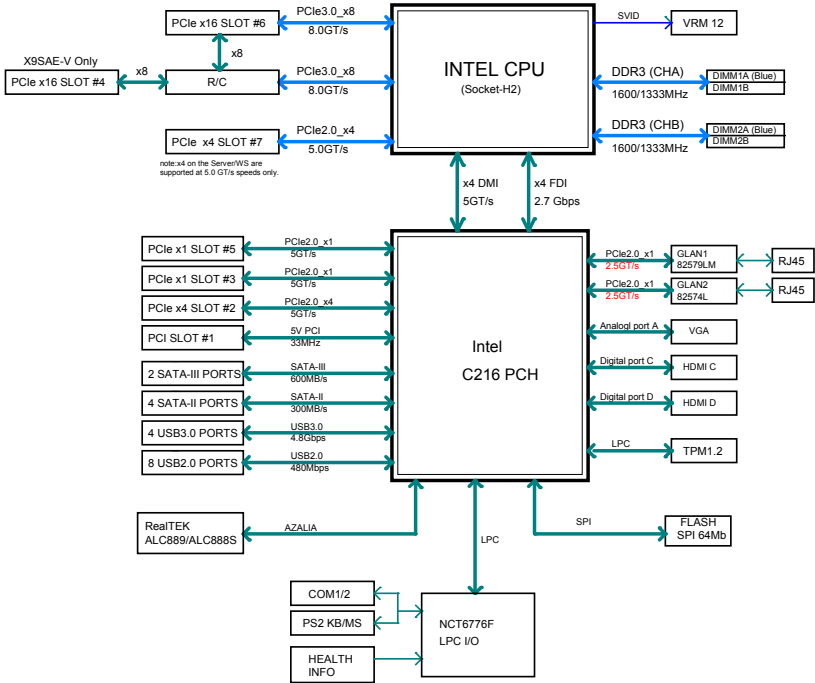

System Block Diagram



Note: This is a general block diagram and may not exactly represent the features on your motherboard. See the Motherboard Features pages for the actual specifications of each motherboard.

1-2 Chipset Overview

The X9SAE Motherboard Series supports a single Intel® Xeon™ E3-1200 v2 series, Xeon™ E3-1200 series, Pentium™, and Celeron™ processor in an LGA 1155 socket. Leveraging the features of the Intel C216 chipset, the X9SAE motherboard provides substantial enhancement to system performance high performance gaming platforms and entry-level workstations.

Intel C216 Chipset Features

- Server-class performance, reliability, and security at entry-level price points
- Enhanced performance and energy-efficiency
- Support for ECC Memory - Better data integrity and system reliability through automatic data correction
- Intel® Rapid Storage Technology (Intel® RST) with E-mail Alerting - Uninterrupted operation and quick data recovery in the event of a hard drive failure
- Intel® OS Guard - Improves security by strengthening malware protection
- PCI Express 3.0 Interface (up to 8.0 GT/s)
- SATA 3.0 Controller (up to 6Gb/sec)
- Intel® Turbo Boost Technology 2.05
- Intel® Hyper-Threading Technology6 (Intel® HT Technology)

Complete specifications are available at Intel's website:

<http://www.intel.com/content/www/us/en/chipsets/server-chipsets/server-chipset-c202.html>

1-3 Special Features

Recovery from AC Power Loss

Basic I/O System (BIOS) provides a setting for you to determine how the system will respond when AC power is lost and then restored to the system. You can choose for the system to remain powered off, (in which case you must press the power switch to turn it back on), or for it to automatically return to a power-on state. See the Advanced BIOS Setup section to change this setting. The default setting is **Last State**.

1-4 PC Health Monitoring

This section describes the PC health monitoring features of the board. All have an onboard System Hardware Monitoring chip that supports PC health monitoring. An onboard voltage monitor will scan these onboard voltages continuously: 1.8V, +3.3V, +5V, +/-12V, +3.3V Stby, +5V Stby, VBAT, HT, Memory, Chipset. Once a voltage becomes unstable, a warning is given, or an error message is sent to the screen. The user can adjust the voltage thresholds to define the sensitivity of the voltage monitor.

Fan Status Monitor with Firmware Control

PC health monitoring in the BIOS can check the RPM status of the cooling fans. The onboard CPU and chassis fans are controlled by Thermal Management via BIOS (under the Hardware Monitoring section in the Advanced Setting).

Environmental Temperature Control

The thermal control sensor monitors the CPU temperature in real time and will turn on the thermal control fan whenever the CPU temperature exceeds a user-defined threshold. The overheat circuitry runs independently from the CPU. Once the thermal sensor detects that the CPU temperature is too high, it will automatically turn on the thermal fans to prevent the CPU from overheating. The onboard chassis thermal circuitry can monitor the overall system temperature and alert the user when the chassis temperature is too high.



Note: To avoid possible system overheating, please be sure to provide adequate airflow to your system.

System Resource Alert

This feature is available when the system is used with SuperDoctor[®] III in the Windows OS environment or used with SuperDoctor[®] II in Linux. SuperDoctor[®] is used to notify the user of certain system events. For example, you can also configure SuperDoctor to provide you with warnings when the system temperature, CPU temperatures, voltages and fan speeds go beyond predefined thresholds.

1-5 ACPI Features

ACPI stands for Advanced Configuration and Power Interface. The ACPI specification defines a flexible and abstract hardware interface that provides a standard way to integrate power management features throughout a PC system, including its hardware, operating system and application software. This enables the system to automatically turn on and off peripherals such as CD-ROMs, network cards, hard disk drives and printers.

In addition to enabling operating system-directed power management, ACPI also provides a generic system event mechanism for Plug and Play, and an operating system-independent interface for configuration control. ACPI leverages the Plug and Play BIOS data structures, while providing a processor architecture-independent implementation that is compatible with Windows XP, Windows Vista, and Windows 2008 Operating Systems.

Slow Blinking LED for Suspend-State Indicator

When the CPU goes into a suspend state, the chassis power LED will start to blink to indicate that the CPU is in suspend mode. When the user presses any key, the CPU will "wake up", and the LED will automatically stop blinking and remain on.

1-6 Power Supply

As with all computer products, a stable power source is necessary for proper and reliable operation. It is even more important for processors that have high CPU clock rates.

This motherboard accommodates 24-pin ATX power supplies. Although most power supplies generally meet the specifications required by the CPU, some are inadequate. In addition, the 12V 8-pin power connector located at JPW2 is also required to ensure adequate power supply to the system. Also your power supply must supply 1.5A for the Ethernet ports.



Caution: 1. To prevent damage to the power supply or motherboard, please use a power supply that contains a 24-pin and a 8-pin power connectors. Be sure to connect these connectors to the 24-pin (JPW1) and the

8-pin (JPW2) power connectors on the motherboard. Failure in doing so will void the manufacturer warranty on your power supply and motherboard.

2. To provide adequate power to Disk on Module SATA devices, please connect them to the SATA DOM PWR connector (JWF1).

It is strongly recommended that you use a high quality power supply that meets ATX power supply Specification 2.02 or above. It must also be SSI compliant. (For more information, please refer to the web site at <http://www.ssiforum.org/>). Additionally, in areas where noisy power transmission is present, you may choose to install a line filter to shield the computer from noise. It is recommended that you also install a power surge protector to help avoid problems caused by power surges.

1-7 Super I/O

The Super I/O supports two high-speed, 16550 compatible serial communication ports (UARTs). Each UART includes a 16-byte send/receive FIFO, a programmable baud rate generator, complete modem control capability and a processor interrupt system. Both UARTs provide legacy speed with baud rate of up to 115.2 Kbps as well as an advanced speed with baud rates of 250 K, 500 K, or 1 Mb/s, which support higher speed modems.

The Super I/O provides functions that comply with ACPI (Advanced Configuration and Power Interface), which includes support of legacy and ACPI power management through an SMI or SCI function pin. It also features auto power management to reduce power consumption.

Notes

Chapter 2

Installation

2-1 Static-Sensitive Devices

Electrostatic-Discharge (ESD) can damage electronic components. To avoid damaging your system board, it is important to handle it very carefully. The following measures are generally sufficient to protect your equipment from ESD.

Precautions

- Use a grounded wrist strap designed to prevent static discharge.
- Touch a grounded metal object before removing the board from the antistatic bag.
- Handle the board by its edges only; do not touch its components, peripheral chips, memory modules or gold contacts.
- When handling chips or modules, avoid touching their pins.
- Put the motherboard and peripherals back into their antistatic bags when not in use.
- For grounding purposes, make sure your computer chassis provides excellent conductivity between the power supply, the case, the mounting fasteners and the motherboard.
- Use only the correct type of onboard CMOS battery. Do not install the onboard battery upside down to avoid possible explosion.

Unpacking

The motherboard is shipped in antistatic packaging to avoid static damage. When unpacking the board, make sure that the person handling it is static protected.

2-2 Processor and Heatsink Installation



Caution: When handling the processor package, avoid placing direct pressure on the label area of the fan.



Important:

Always connect the power cord last, and always remove it before adding, removing or changing any hardware components. Make sure that you install the processor into the CPU socket before you install the CPU heatsink.

If you buy a CPU separately, make sure that you use an Intel-certified multi-directional heatsink only.

Make sure to install the system board into the chassis before you install the CPU heatsink.

When receiving a server board without a processor pre-installed, make sure that the plastic CPU socket cap is in place and none of the socket pins are bent; otherwise, contact your retailer immediately.

Refer to the Supermicro website for updates on CPU support.

Installing the LGA1155 Processor

1. Press the load lever to release the load plate, which covers the CPU socket, from its locking position.

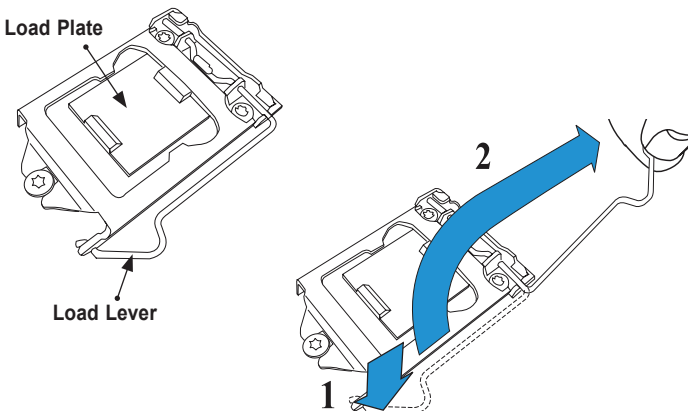

2. Gently lift the load lever to open the load plate. Remove the plastic cap.

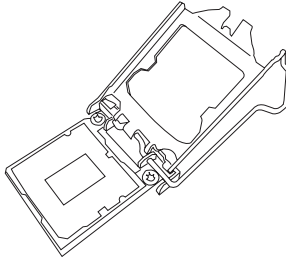

3. Use your thumb and your index finger to hold the CPU at the North center edge and the South center edge of the CPU.

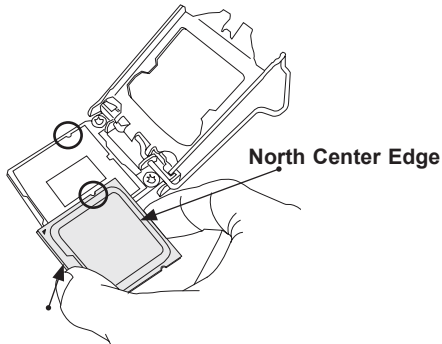

South Center Edge

4. Align the CPU key that is the semi-circle cutouts against the socket keys. Once it is aligned, carefully lower the CPU straight down into the socket. (Do not drop the CPU on the socket. Do not move the CPU horizontally or vertically.)

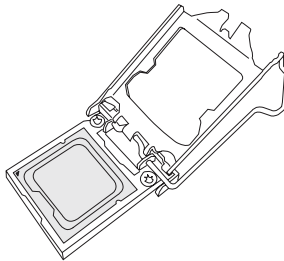

5. Do not rub the CPU against the surface or against any pins of the socket to avoid damaging the CPU or the socket.)

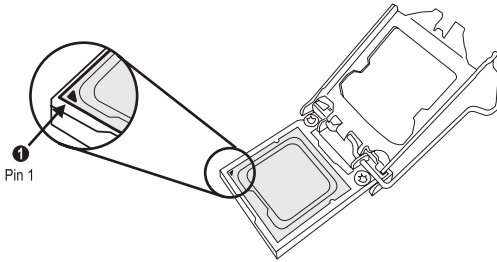

6. With the CPU inside the socket, inspect the four corners of the CPU to make sure that the CPU is properly installed.
7. Use your thumb to gently push the load lever down to the lever lock.

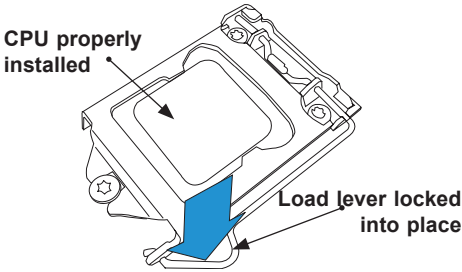

Caution: You can only install the CPU inside the socket only in one direction. Make sure that it is properly inserted into the CPU socket before closing the load plate. If it doesn't close properly, do not force it as it may damage your CPU. Instead, open the load plate again and double-check that the CPU is aligned properly.

Installing an Active CPU Heatsink with Fan

1. Locate the CPU Fan power connector on the motherboard. (Refer to the layout on the right for the CPU Fan location.)
2. Position the heatsink so that the heatsink fan wires are closest to the CPU fan power connector and are not interfered with other components.
3. Inspect the CPU Fan wires to make sure that the wires are routed through the bottom of the heatsink.
4. Remove the thin layer of the protective film from the heatsink.



Caution: CPU overheat may occur if the protective film is not removed from the heatsink.

5. Apply the proper amount of thermal grease on the CPU.



Note: if your heatsink came with a thermal pad, please ignore this step.

6. If necessary, rearrange the wires to make sure that the wires are not pinched between the heatsink and the CPU. Also make sure to keep clearance between the fan wires and the fins of the heatsink.

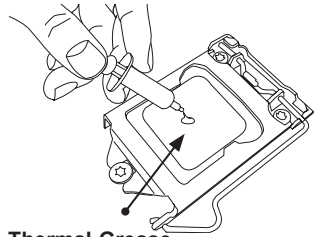

Thermal Grease

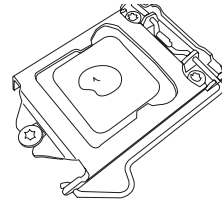

Heatsink Fins

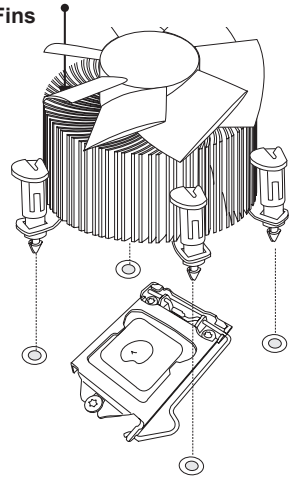

**Recommended Supermicro heatsink:
SNK-P0046A4 active heatsink**

7. Align the four heatsink fasteners with the mounting holes on the motherboard. Gently push the pairs of diagonal fasteners (#1 & #2, and #3 & #4) into the mounting holes until you hear a click. Also, make sure to orient each fastener so that the narrow end of the groove is pointing outward.
8. Repeat Step 7 to insert all four heatsink fasteners into the mounting holes.
9. Once all four fasteners are securely inserted into the mounting holes, and the heatsink is properly installed on the motherboard, connect the heatsink fan wires to the CPU Fan connector.

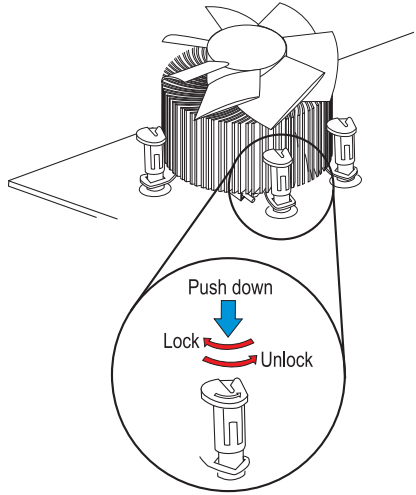

Removing the Heatsink



Caution: We do not recommend that the CPU or the heatsink be removed. However, if you do need to remove the heatsink, please follow the instructions below to remove the heatsink and to prevent damage done to the CPU or other components.

Active Heatsink Removal

1. Unplug the power cord from the power supply.
2. Disconnect the heatsink fan wires from the CPU fan header.
3. Use your finger tips to gently press on the fastener cap and turn it counterclockwise to make a 1/4 (90°) turn, and pull the fastener upward to loosen it.
4. Repeat Step 3 to loosen all fasteners from the mounting holes.
5. With all fasteners loosened, remove the heatsink from the CPU.

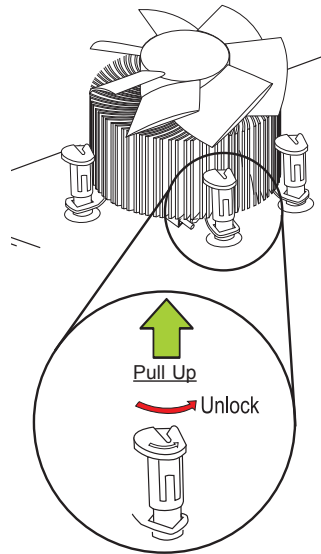
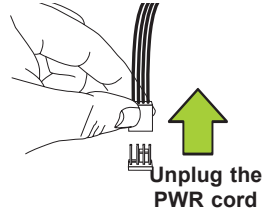

2-3 Installing DDR3 Memory



Note: Check the Supermicro website for recommended memory modules.

CAUTION



Exercise extreme care when installing or removing DIMM modules to prevent any possible damage.

DIMM Installation

1. Insert the desired number of DIMMs into the memory slots, starting with DIMMA2 (Slot 2, Channel A, see the next page for the location). For best performance, please use the memory modules of the same type and speed in the same bank.
2. Push the release tabs outwards on both ends of the DIMM slot to unlock it.
3. Align the key of the DIMM module with the receptive point on the memory slot.
4. Align the notches on both ends of the module against the receptive points on the ends of the slot.
5. Use two thumbs together to press the notches on both ends of the module straight down into the slot until the module snaps into place.
6. Press the release tabs to the lock positions to secure the DIMM module into the slot.

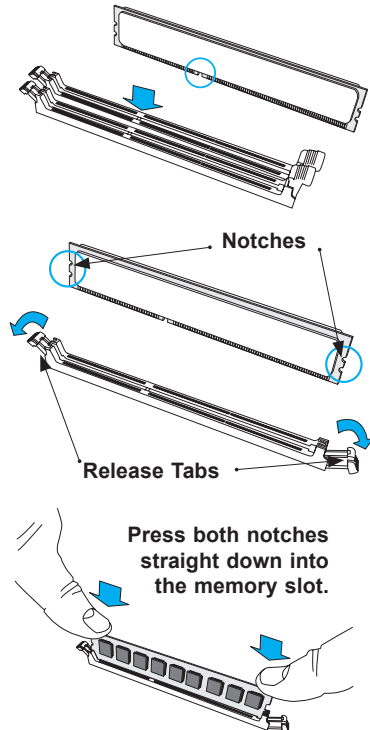
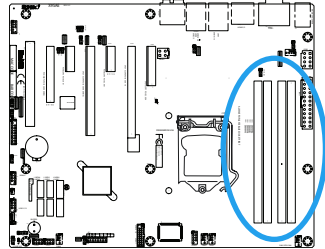

Removing Memory Modules

Reverse the steps above to remove the DIMM modules from the motherboard.

Memory Support

The X9SAE Motherboard Series supports up to 32GB of Unbuffered (UDIMM) DDR3 ECC/Non-ECC 1600/1333/1066 MHz in 4 memory slots. Populating these DIMM modules with a pair of memory modules of the same type and same size will result in interleaved memory, which will improve memory performance. Please refer to the table below:

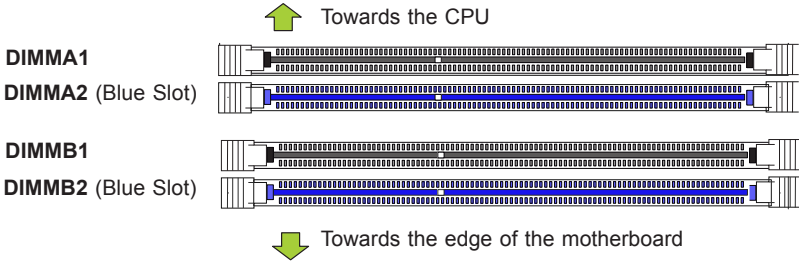

Memory Population Guidelines

When installing memory modules, the DIMM slots should be populated in the following order: DIMMA2, DIMMB2, DIMMA1 and DIMMB1.

- Always use DDR3 DIMM modules of the same size, type and speed.
- Mixed DIMM speeds can be installed. However, all DIMMs will run at the speed of the slowest DIMM.
- The motherboard will support one DIMM module or three DIMM modules installed. For best memory performance, install DIMM modules in pairs.

Recommended Population (Balanced)				
DIMMA2 Slot	DIMMB2 Slot	DIMMA1 Slot	DIMMB1 Slot	Total System Memory
2GB	2GB			4GB
2GB	2GB	2GB	2GB	8GB
4GB	4GB			8GB
4GB	4GB	4GB	4GB	16GB
8GB	8GB			16GB
8GB	8GB	8GB	8GB	32GB



Note: Due to memory allocation to system devices, the amount of memory that remains available for operational use will be reduced when 4 GB of RAM is used. The reduction in memory availability is disproportional. See the following table for details.

Possible System Memory Allocation & Availability		
Area Reserved for the chipset	2 MB	3.99
I/O APIC (4 Kbytes)	4 KB	3.99
PCI Enumeration Area 1	256 MB	3.76
PCI Express (256 MB)	256 MB	3.51
PCI Enumeration Area 2 (if needed) -Aligned on 256-MB boundary-	512 MB	3.01
VGA Memory	16 MB	2.85
TSEG	1 MB	2.84
Memory available to OS and other applications		2.84

2-4 Motherboard Installation

All motherboards have standard mounting holes to fit different types of chassis. Make sure that the locations of all the mounting holes for both motherboard and chassis match. Although a chassis may have both plastic and metal mounting fasteners, metal ones are highly recommended because they ground the motherboard to the chassis. Make sure that the metal standoffs click in or are screwed in tightly. Then use a screwdriver to secure the motherboard onto the motherboard tray.

Tools Needed

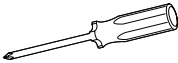

Philips Screwdriver



Philips Screws



Standoffs
Only if Needed

Location of Mounting Holes

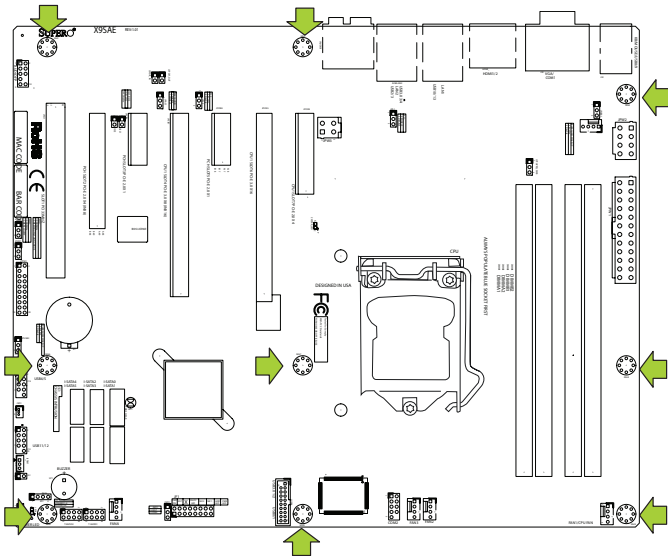

Caution: 1) To avoid damaging the motherboard and its components, please do not use a force greater than 8 lb/inch on each mounting screw during motherboard installation. 2) Some components are very close to the mounting holes. Please take precautionary measures to avoid damaging these components when installing the motherboard to the chassis.

Installing the Motherboard

1. Install the I/O shield into the back of the chassis.

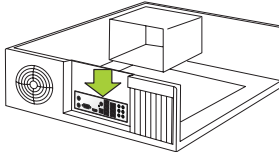

2. Locate the mounting holes on the motherboard. (See the previous page.)
3. Locate the matching mounting holes on the chassis. Align the mounting holes on the motherboard against the mounting holes on the chassis.
4. Install standoffs in the chassis as needed.

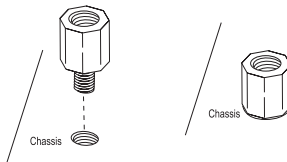

5. Install the motherboard into the chassis carefully to avoid damaging other motherboard components.
6. Using the Philips screwdriver, insert a Philips head #6 screw into a mounting hole on the motherboard and its matching mounting hole on the chassis.

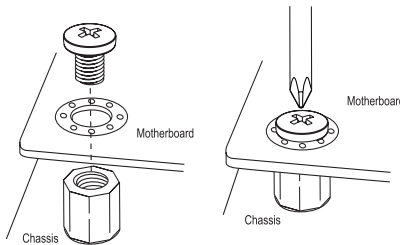

7. Repeat Step 5 to insert #6 screws into all mounting holes.
8. Make sure that the motherboard is securely placed in the chassis.



Note: Images displayed are for illustration only. Your chassis or components might look different from those shown in this manual.

2-5 Connectors/I/O Ports

The I/O ports are color coded in conformance with the industry standards. See the figure below for the colors and locations of the various I/O ports.

Backplane I/O Panel

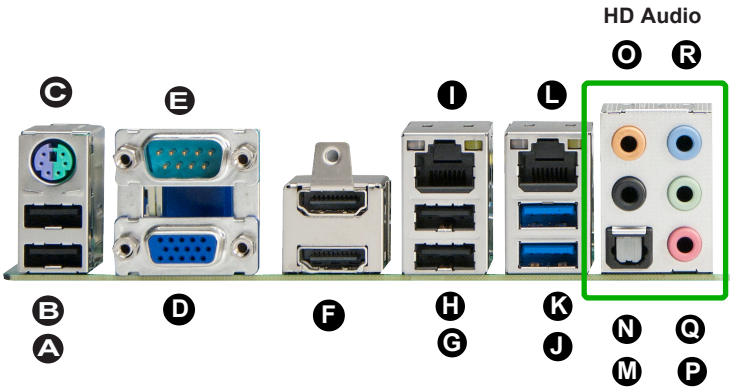
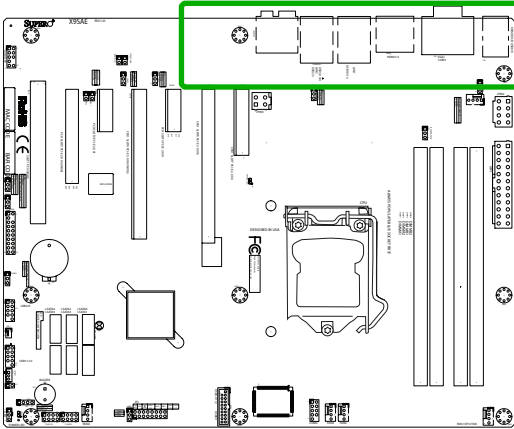

Back Panel		
A. USB 2.0 Port 9	G. USB 2.0 Port 10	M. SPDIF Out
B. USB 2.0 Port 8	H. USB 2.0 Port 13	N. Surround Out
C. Keyboard/Mouse	I. Gb LAN Port 1	O. Center/LFE Out
D. VGA Port	J. USB 2.0 Port 3**	P. Mic In
E. Serial Port (COM1)	K. USB 2.0 Port 2*	Q. Line Out
F. HDMI1/HDMI2 Ports	L. Gb LAN Port 2	R. Line In

*USB 3.0 Port 3 **USB 3.0 Port 4

HD Audio

ATX PS/2 Keyboard/Mouse Ports

The ATX PS/2 keyboard and PS/2 mouse are located next to the Back Panel USB Ports 8/9 on the motherboard. See the table at right for pin definitions.

PS/2 Keyboard/Mouse Pin Definitions			
PS2 Keyboard		PS2 Mouse	
Pin#	Definition	Pin#	Definition
1	KB Data	1	Mouse Data
2	No Connection	2	No Connection
3	Ground	3	Ground
4	Mouse/KB VCC (+5V)	4	Mouse/KB VCC (+5V)
5	KB Clock	5	Mouse Clock
6	No Connection	6	No Connection

VCC: with 1.5A PTC (current limit)



Note:

This motherboard offers three Keyboard/Mouse connection options as shown in the graphic below.

- **A.** Plug in a PS/2 keyboard or PS/2 Mouse cable to the PS2 Keyboard/Mouse port.
- **B.** Plug in a Y cable that that includes a keyboard cable and mouse cable to the PS/2 Keyboard/Mouse port..
- **C.** Connect a USB keyboard cable or a USB mouse cable to any USB port.

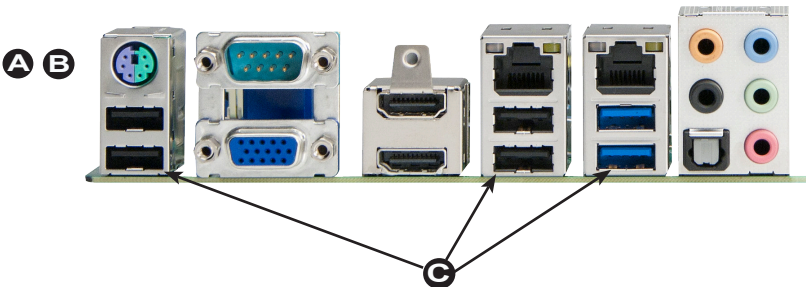
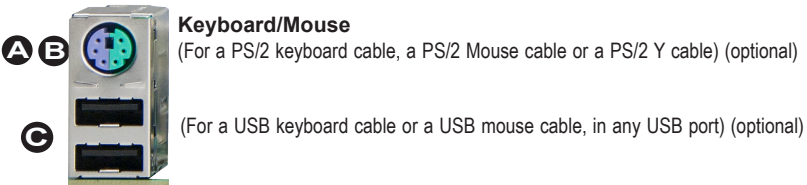

Universal Serial Bus (USB)

Four Universal Serial Bus 2.0 ports #2, #3, #8, #9, #10, #13, USB 3.0 #3, #4, are located on the I/O back panel. USB 2.0 headers #4/5, #11/12, #0/1 and USB 3.0 header #1/2 are used to provide front chassis access using USB cables (not included). See the tables below for pin definitions.

Front Panel USB (2.0) Pin Definitions			
Pin #	Definition	Pin #	Definition
1	+5V	2	+5V
3	USB_PN2	4	USB_PN3
5	USB_PP2	6	USB_PP3
7	Ground	8	Ground
9	Key	10	Ground

Back Panel USB (2.0) Pin Definitions			
Pin#	Definition	Pin#	Definition
1	+5V	5	+5V
2	USB_PN1	6	USB_PN0
3	USB_PP1	7	USB_PP0
4	Ground	8	Ground

- A. Backpanel USB 2.0 #9
- B. Backpanel USB 2.0 #8
- C. Backpanel USB 2.0 #13
- D. Backpanel USB 2.0 #10
- E. Backpanel USB 2.0 #3
(USB 3.0 #4)
- F. Backpanel USB 2.0 #2
(USB 3.0 #3)
- G. Front Panel USB 2.0 #4/5
- H. Front Panel USB 2.0 #11/12
- I. Front Panel USB 2.0 #0/1
(USB 3.0 #1/2)

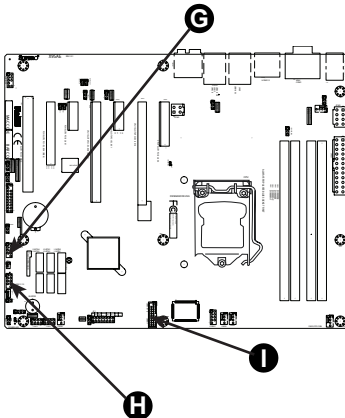

Front Panel USB (3.0) Pin Definitions		
Pin#	Signal Name	Description
1	VBUS	Power
2	IntA_P1_SSRX-	USB 3.0 Port 1 SuperSpeed RX-
3	IntA_P1_SSRX+	USB 3.0 Port 1 SuperSpeed RX+
4	GND	GND
5	IntA_P1_SSTX-	USB 3.0 Port 1 SuperSpeed TX-
6	IntA_P1_SSTX+	USB 3.0 Port 1 SuperSpeed TX+
7	GND	GND
8	IntA_P1_D-	USB 3.0 Port 1 D- (USB 2.0 Signal D-)
9	IntA_P1_D+	USB 3.0 Port 1 D+ (USB 2.0 Signal D+)
10	ID	Over Current Protection
11	IntA_P2_D+	USB 3.0 Port 2 D+ (USB 2.0 Signal D+)
12	IntA_P2_D-	USB 3.0 Port 2 D- (USB 2.0 Signal D-)
13	GND	GND
14	IntA_P2_SSTX+	USB 3.0 Port 2 SuperSpeed TX+
15	IntA_P2_SSTX-	USB 3.0 Port 2 SuperSpeed TX-
16	GND	GND
17	IntA_P2_SSRX+	USB 3.0 Port 2 SuperSpeed RX+
18	IntA_P2_SSRX-	USB 3.0 Port 2 SuperSpeed RX-
19	VBUS	Power

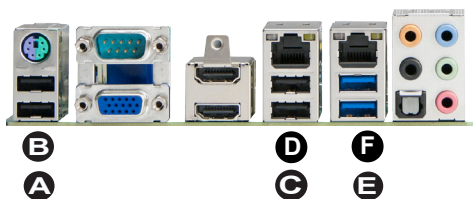

Ethernet Ports

Two Gigabit Ethernet ports (LAN1/LAN2) are located next to the HD Audio Connector on the I/O Backpanel to provide network connections. These ports accept RJ45 type cables.



Note:

Please refer to the LED Indicator Section for LAN LED information.

LAN Ports Pin Definition			
Pin#	Definition		
1	P2V5SB	10	SGND
2	TD0+	11	Act LED
3	TD0-	12	P3V3SB
4	TD1+	13	Link 100 LED (Green, +3V3SB)
5	TD1-	14	Link 1000 LED (Yellow, +3V3SB)
6	TD2+	15	Ground
7	TD2-	16	Ground
8	TD3+	17	Ground
9	TD3-	88	Ground

(NC: No Connection)

A. LAN1

B. LAN2

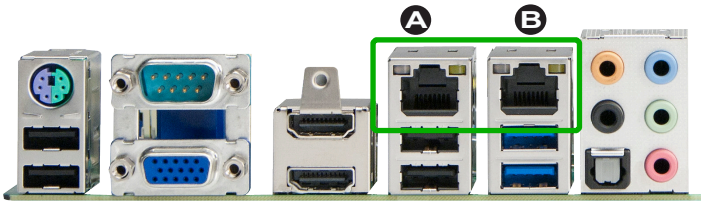

Back Panel High Definition Audio (HD Audio)

This motherboard features a 7.1+2 Channel High Definition Audio (HDA) codec that provides 10 DAC channels. The HD Audio connections simultaneously supports multiple-streaming 7.1 sound playback with 2 channels of independent stereo output through the front panel stereo out for front, rear, center and subwoofer speakers. Use the Advanced software included in the CD-ROM with your motherboard to enable this function.

(BP) HD Audio	
Conn#	Signal
A	SPDIF_Out
B	Surround_Out
C	CEN/LFE_Out
D	Mic_In
E	Line_Out
F	Line_In

HD Audio

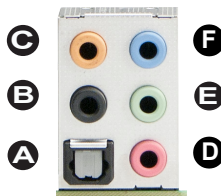

- A. SPDIF_Out
- B. Surround_Out
- C. CEN/LFE_Out
- D. Mic_In
- E. Line-Out
- F. Line_In

Front Accessible Audio Header

A 10-pin Audio header is also located on the motherboard. This header allows you to use the on-board sound for audio playback. Connect an audio cable to the audio header to use this feature. See the tables at right for pin definitions for these headers.

10-in Audio Pin Definitions	
Pin#	Signal
1	Microphone_Left
2	Audio_Ground
3	Microphone_Right
4	Audio_Detect
5	Line_2_Right
6	Ground
7	Jack_Detect
8	Key
9	Line_2_Left
10	Ground

A. Audio Header

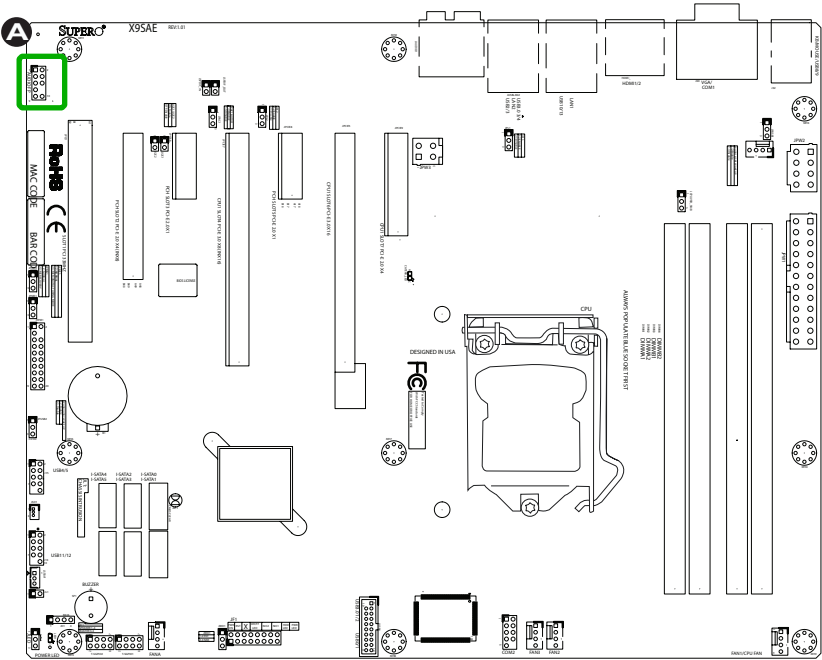

HDMI Ports

Two HDMI (High-Definition Multimedia Interface) Ports are located next to the VGA port on the I/O backpanel. This connector is used to display both high definition video and digital sound through an HDMI-capable display, using a single HDMI cable (not included).

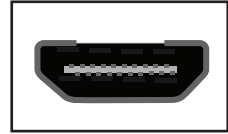

VGA Port

A VGA port is located next to the USB ports on the I/O backpanel. Use this port to connect to a compatible VGA display.

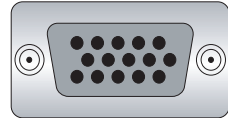

Serial Port (COM1)

Serial port COM1 is located on the I/O backpanel. Another serial port (COM2) is available through a header on the motherboard. See the table on the right for pin definitions.

Serial Ports Pin Definitions			
Pin #	Definition	Pin #	Definition
1	DCD	6	DSR
2	RXD	7	RTS
3	TXD	8	CTS
4	DTR	9	RI
5	Ground	10	N/A

A. HDMI Ports

B. VGA Port

C. COM1 Port

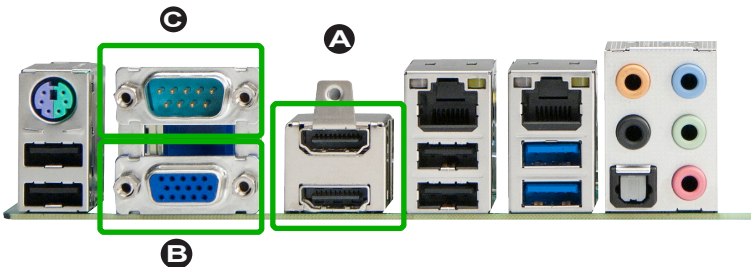

Front Control Panel

JF1 contains header pins for various buttons and indicators that are normally located on a control panel at the front of the chassis. These connectors are designed specifically for use with Supermicro chassis. See the figure below for the descriptions of the front control panel buttons and LED indicators. Refer to the following section for descriptions and pin definitions.

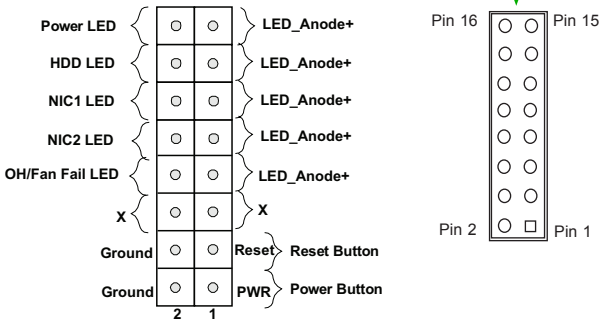
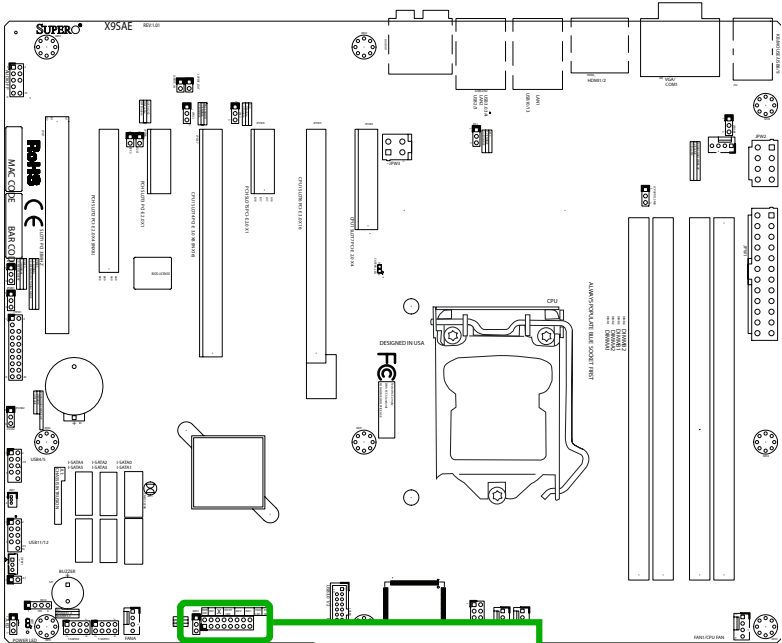

JF1 Header Pins

Front Control Panel Pin Definitions

Power LED

The Power LED connection is located on pins 15 and 16 of JF1. Refer to the table on the right for pin definitions.

Power LED Pin Definitions (JF1)	
Pin#	Definition
15	+5V
16	Ground

HDD LED

The HDD LED connection is located on pins 13 and 14 of JF1. Attach a cable here to indicate the status of HDD-related activities, including IDE, SATA activities. See the table on the right for pin definitions.

HDD LED Pin Definitions (JF1)	
Pin#	Definition
13	+5V
14	HD Active

A. PWR LED

B. HDD LED

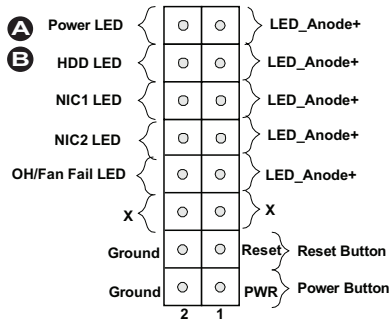

NIC1/NIC2 (LAN1/LAN2)

The NIC (Network Interface Controller) LED connection for LAN port 1 is located on pins 11 and 12 of JF1, and the LED connection for LAN Port 2 is on Pins 9 and 10. NIC1 LED and NIC2 LED are 2-pin NIC LED headers. Attach NIC LED cables to NIC1 and NIC2 LED indicators to display network activities. Refer to the table on the right for pin definitions.

LAN1/LAN2 LED Pin Definitions (JF1)	
Pin#	Definition
9/11	Vcc
10/12	Ground

Overheat (OH)/Fan Fail

Connect an LED cable to OH/Fan Fail connections on pins 7 and 8 of JF1 to provide warnings for chassis overheat/fan failure. Refer to the table on the right for pin definitions.

OH/Fan Fail LED Pin Definitions (JF1)	
Pin#	Definition
7	Vcc/Blue UID LED
8	OH/Fan Fail LED

OH/Fan Fail Indicator Status	
State	Definition
Off	Normal
On	Overheat
Flashing	Fan Fail

A. NIC1 LED

B. NIC2 LED

C. OH/Fan Fail

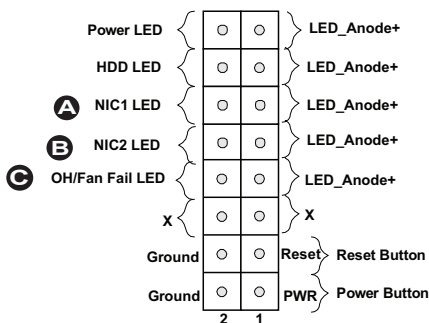

Reset Button

The Reset Button connection is located on pins 3 and 4 of JF1. Attach it to a hardware reset switch on the computer case to reset the system. Refer to the table on the right for pin definitions.

Reset Button Pin Definitions (JF1)	
Pin#	Definition
3	Reset
4	Ground

Power Button

The Power Button connection is located on pins 1 and 2 of JF1. Momentarily contacting both pins will power on/off the system. This button can also be configured to function as a suspend button (with a setting in the BIOS - see Chapter 4). To turn off the power in the suspend mode, press the button for at least 4 seconds. Refer to the table on the right for pin definitions.

Power Button Pin Definitions (JF1)	
Pin#	Definition
1	Signal
2	+3V Standby

A. Reset Button

B. PWR Button

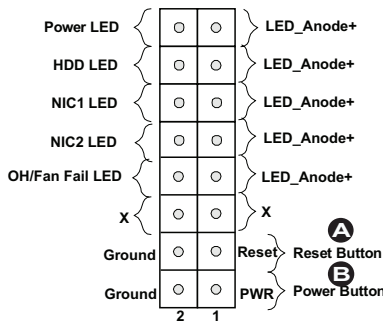

2-6 Connecting Cables

This section provides brief descriptions and pinout definitions for onboard headers and connectors. Be sure to use the correct cable for each header or connector.

ATX Main PWR & CPU PWR Connectors (JPW1 & JPW2)

The 24-pin main power connector (JPW1) is used to provide power to the motherboard. The 8-pin CPU PWR connector (JPW2) is also required for the processor. The 4-pin Auxilliary PWR (JPW3) is optional to provide additional power for the expansion slots. These power connectors meet the SSI EPS 12V specification. See the table on the right and below for pin definitions.

ATX Power 24-pin Connector Pin Definitions (JPW1)			
Pin#	Definition	Pin #	Definition
13	+3.3V	1	+3.3V
14	-12V	2	+3.3V
15	COM	3	COM
16	PS_ON	4	+5V
17	COM	5	COM
18	COM	6	+5V
19	COM	7	COM
20	Res (NC)	8	PWR_OK
21	+5V	9	5VSB
22	+5V	10	+12V
23	+5V	11	+12V
24	COM	12	+3.3V

12V 8-pin Power Connector Pin Definitions	
Pins	Definition
1 through 4	Ground
5 through 8	+12V

(Required)

12V 4-pin Power Connector Pin Definitions	
Pins	Definition
1 through 2	Ground
3 through 4	+12V

A. 24-Pin ATX Main PWR

B. 8-Pin CPU PWR

C. 4-Pin Auxilliary PWR

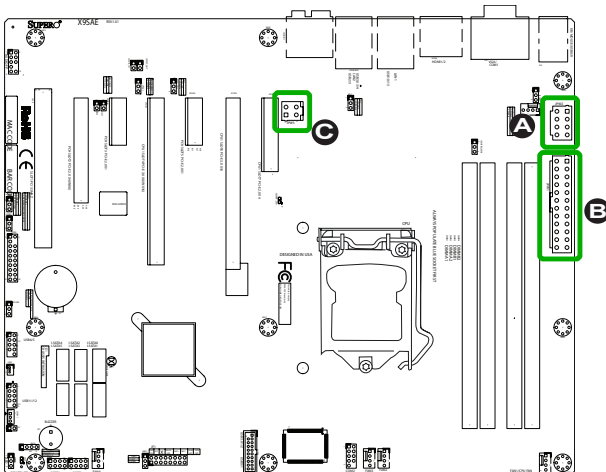

Fan Headers (FAN 1 ~ FAN 4, FAN A)

The X9SAE Motherboard Series has five fan headers (Fan 1~Fan 4 & Fan A). These fans are 4-pin fan headers. Although pins 1-3 of the fan headers are backward compatible with the traditional 3-pin fans, we recommend the use 4-pin fans to take advantage of the fan speed control in the BIOS Hardware Monitoring section. This allows the BIOS to automatically adjust fan speeds based on the motherboard's detected system temperature. Refer to the table on the right for pin definitions.

Fan Header Pin Definitions	
Pin#	Definition
1	Ground (Black)
2	2.5A/+12V (Red)
3	Tachometer
4	PWM_Control

Chassis Intrusion (JL1)

A Chassis Intrusion header is located at JL1 on the motherboard. Attach the appropriate cable from the chassis to inform you of a chassis intrusion when the chassis is opened.

Chassis Intrusion Pin Definitions (JL1)	
Pin#	Definition
1	Intrusion Input
2	Ground

- A. Fan 1 (CPU Fan)
- B. Fan 2
- C. Fan 3
- D. Fan 4
- E. Fan A (I/O Fan)
- F. Chassis Intrusion

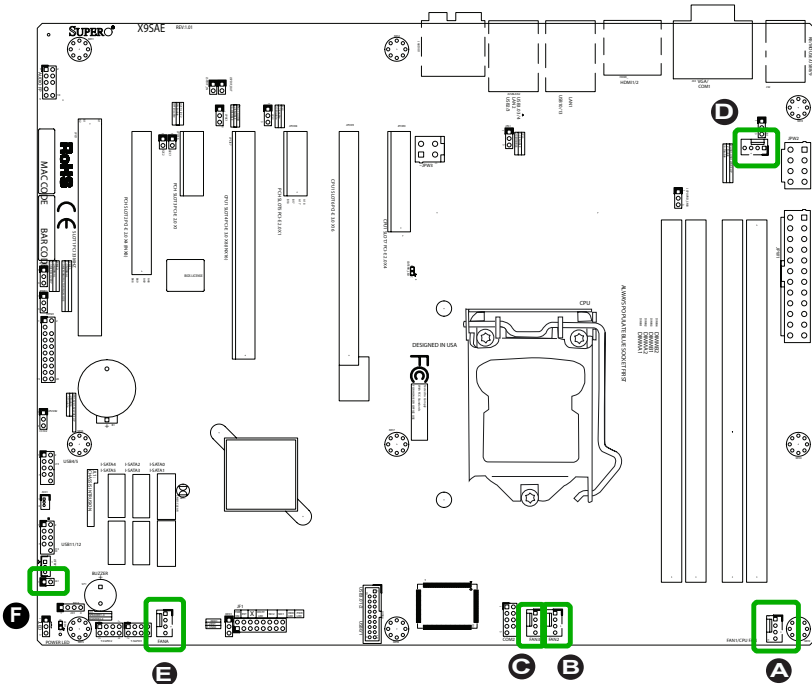

Internal Buzzer (SPK1)

The Internal Buzzer (SPK1) can be used to provide audible indications for various beep codes. See the table on the right for pin definitions.

Internal Buzzer Pin Definition		
Pin#	Definitions	
Pin 1	Pos. (+)	Beep In
Pin 2	Neg. (-)	Alarm Speaker

Speaker (JD1)

On the JD1 header, Pins 3~4 are used for internal speaker. Close Pins 3~4 with a cap to use the onboard speaker. If you wish to use an external speaker, close Pins 1~4 with the external speaker cable. See the table on the right for pin definitions.

Speaker Connector Pin Definitions	
Pin Setting	Definition
Pins 3~4	Internal Speaker
Pins 1~4	External Speaker

A. Internal Buzzer

B. Speaker Header

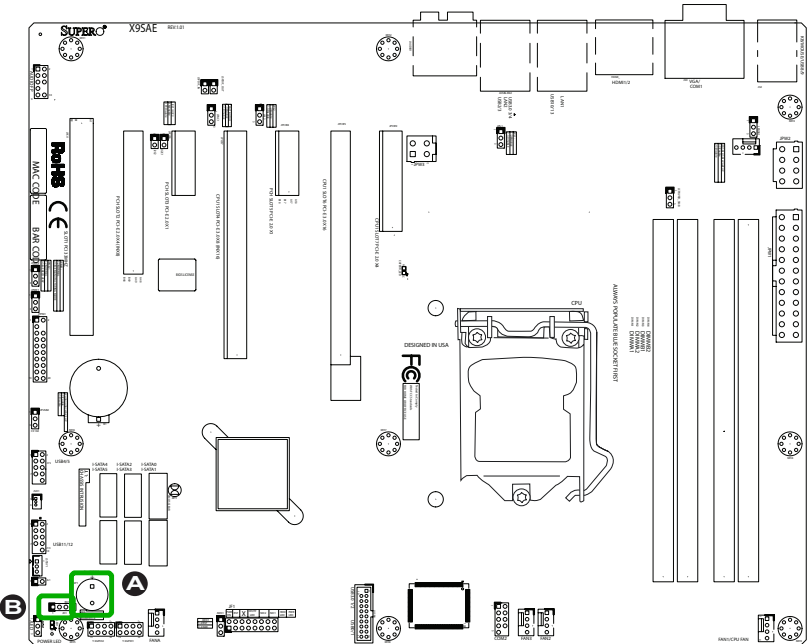

Onboard Power LED (JLED)

An onboard Power LED header is located at JLED. This Power LED header is connected to the Front Control Panel located at JF1 to indicate the status of system power. See the table on the right for pin definitions.

Onboard PWR LED Pin Definitions	
Pin#	Definition
1	VCC
2	No Connection
3	Connection to PWR LED in JF1

Serial Ports (COM1 ~ COM2)

In addition to COM1, which is located on the I/O back panel, there is another Serial port header on the motherboard for COM2. See the table on the right for pin definitions.

Serial Ports Pin Definitions			
Pin #	Definition	Pin #	Definition
1	DCD	6	DSR
2	RXD	7	RTS
3	TXD	8	CTS
4	DTR	9	RI
5	Ground	10	N/A

- A. PWR LED
- B. COM1
- C. COM2

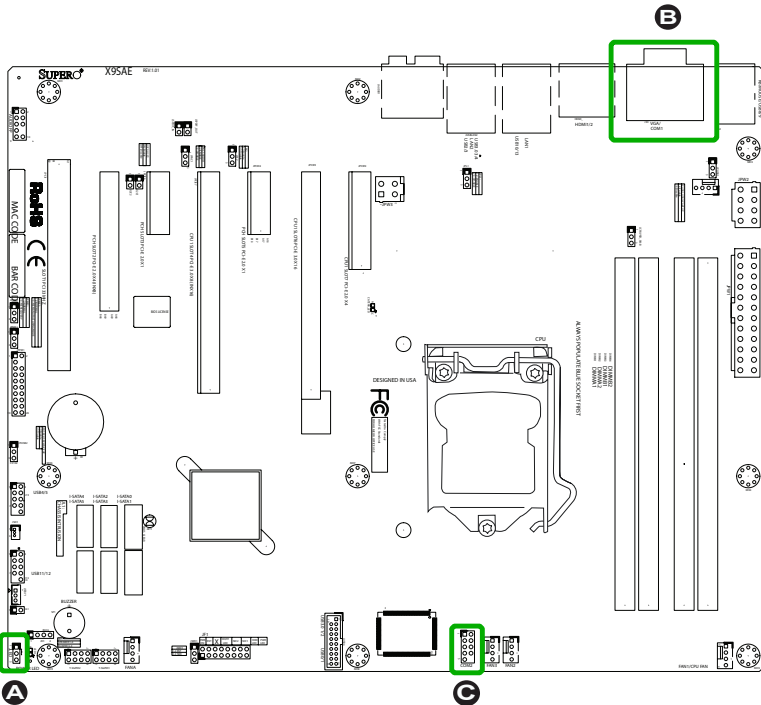

DOM PWR Connector (JSD1)

The Disk-On-Module (DOM) power connector, located at JSD1, provides 5V (Gen1/Gen) power to a solid state DOM storage device connected to one of the SATA ports. See the table on the right for pin definitions.

DOM PWR Pin Definitions	
Pin#	Definition
1	5V
2	Ground
3	Ground

Legacy Wake-On-LAN (JSTBY)

The legacy Wake-On-LAN header is located at JWOL on the motherboard. See the table on the right for pin definitions. (This feature is provided for legacy I/O expansion cards.)

Wake-On-LAN Pin Definitions (JWOL)	
Pin#	Definition
1	+5V Standby
2	Ground
3	Wake-up

A. DOM PWR

B. JSTBY

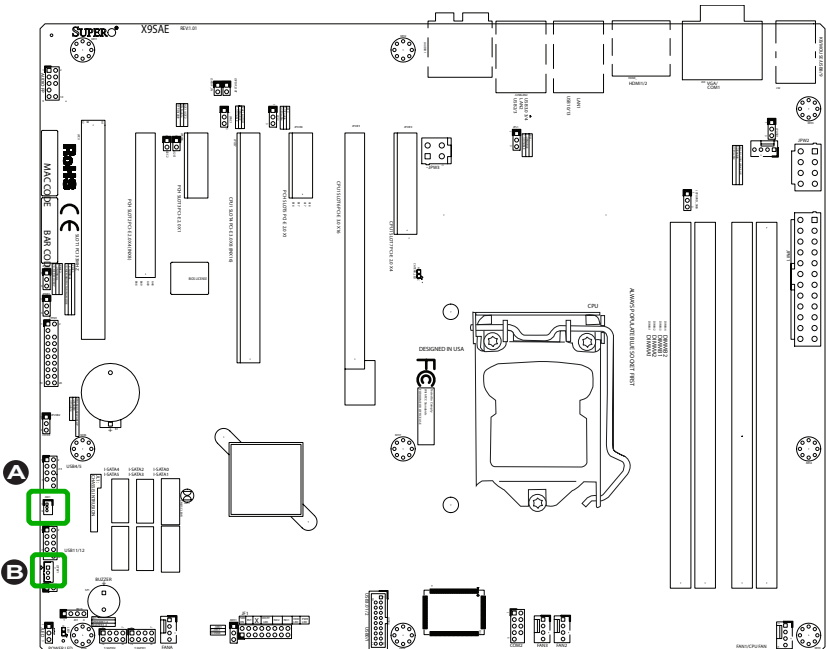

**SPDIF IN / SPDIF OUT (JSPDIF_IN/
JSPDIF_OUT)**

The SP/DIF In (JSPDIF_IN) and SP/DIF Out (JSPDIF_OUT) are used for digital audio. You will also need the appropriate cables to use these features.

SPDIF_In Pin Definitions	
Pin#	Definition
1	S/PDIF_In
2	Ground

SPDIF_Out Pin Definitions	
Pin#	Definition
1	S/PDIF_Out
2	Ground

TPM Header (JTPM1)

A Trusted Platform Module/Port 80 header is located at JTPM1 to provide TPM support and Port 80 connection. Use this header to enhance system performance and data security. See the table on the right for pin definitions.

TPM/Port 80 Header Pin Definitions			
Pin #	Definition	Pin #	Definition
1	LCLK	2	GND
3	LFRAME#	4	<(KEY)>
5	LRESET#	6	+5V (X)
7	LAD 3	8	LAD 2
9	+3.3V	10	LAD1
11	LAD0	12	GND
13	SMB_CLK4	14	SMB_DAT4
15	+3V_DUAL	16	SERIRQ
17	GND	18	CLKRUN# (X)
19	LPCPD#	20	LDRQ# (X)

A. SPDIF_IN

B. SPDIF_OUT

C. TPM Header

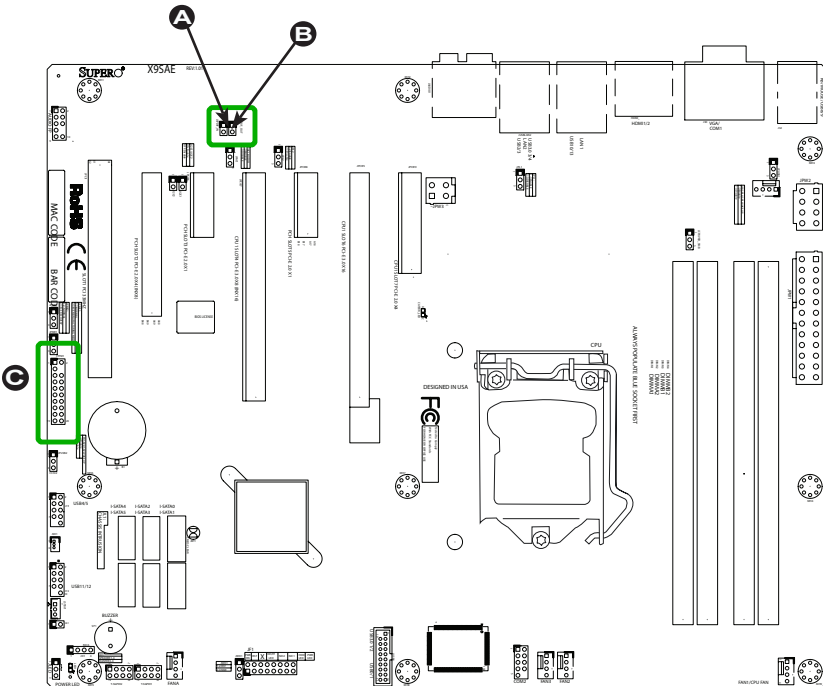

T-SGPIO Headers (T-SGPIO1/2)

The T-SGPIO1 and T-SGPIO2 (Serial-Link General Purpose Input/Output) headers are located near the SATA connectors on the motherboard. These headers are used to communicate with the enclosure management chip in the system. See the table on the right for pin definitions. Refer to the board layout below for the locations of the headers.

Serial_Link-SGPIO Pin Definitions			
Pin#	Definition	Pin	Definition
1	NC	2	NC
3	Ground	4	DATA Out
5	Load	6	Ground
7	Clock	8	NC

A. T-SGPIO1

B. T-SGPIO2

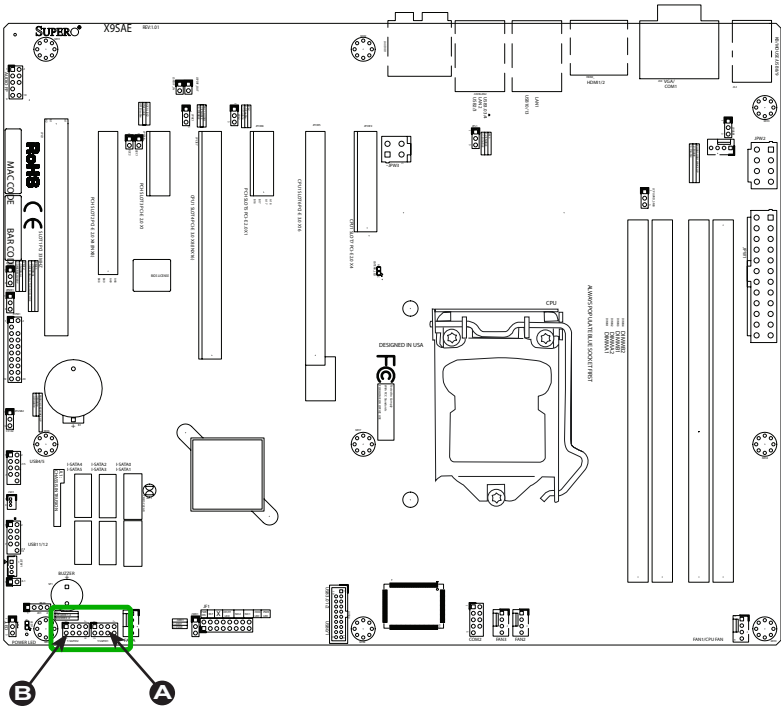

2-7 Jumper Settings

Explanation of Jumpers

To modify the operation of the motherboard, jumpers can be used to choose between optional settings. Jumpers create shorts between two pins to change the function of the connector. Pin 1 is identified with a square solder pad on the printed circuit board.



Note: On two pin jumpers, "Closed" means the jumper is on, and "Open" means the jumper is off the pins.

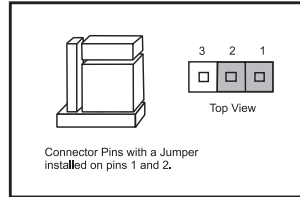
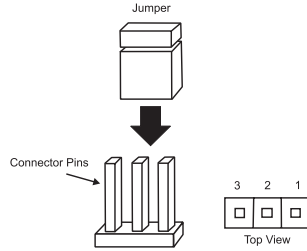

LAN Port Enable/Disable (JPL1/JPL2)

Jumpers JPL1/JPL2 enables or disables LAN Port 1/2 on the motherboard. See the table on the right for jumper settings. The default setting is enabled.

GLAN Enable Jumper Settings	
Pin#	Definition
1-2	Enabled (default)
2-3	Disabled

A. LAN Port 1 Enable

B. LAN Port 2 Enable

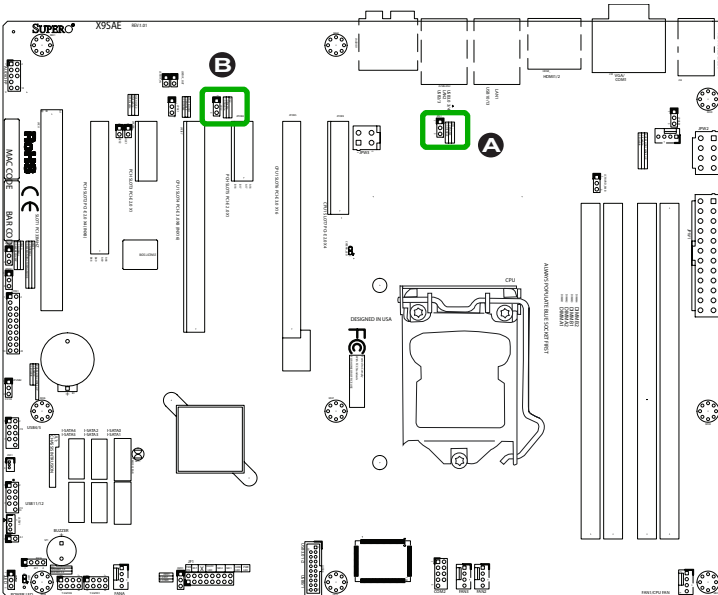

CMOS Clear (JBT1)

JBT1 is used to clear the saved system setup stored in the CMOS chip. To clear the contents of the CMOS, completely shut down the system, remove the AC power cord and then short JBT1 with a jumper. Remove the jumper before powering on the system again. This will erase all user settings and revert everything to their factory-set defaults.

PCI Slot SMB Enable (I²C1/I²C2)

Use Jumpers I²C1/I²C2 to enable PCI SMB (System Management Bus) support to improve system management for the PCI slots. See the table on the right for jumper settings.

PCI Slot_SMB Enable Jumper Settings	
Jumper Setting	Definition
Short	Enabled
Open (Default)	Disabled

A. Clear CMOS

B. JI²C1

C. JI²C2

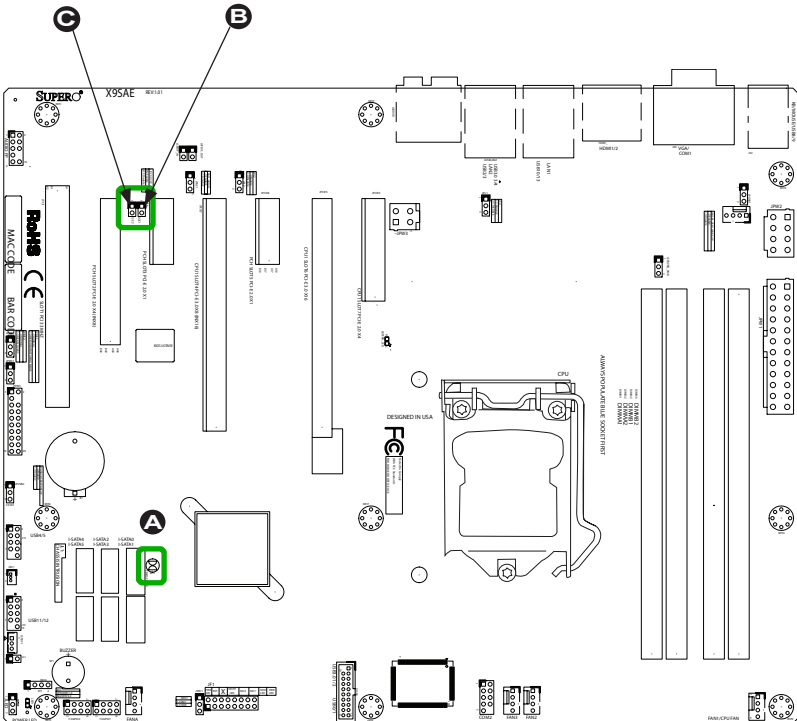

ME Manufacturing Mode (JPME2)

Close pins 2-3 of JPME2 to enable ME Manufacturing Mode. See the table on the right for jumper settings. Note: ME Manufacturing Mode may be enabled without changing this jumper through the BIOS setup. See PCH-FW Configuration -> Firmware Update Configuration in the BIOS Setup. The /ME parameter must be specified when updating with the DOS utility.

JPME2 Jumper Settings	
Both Jumpers	Definition
Pins 1-2	Disabled
Pins 2-3	Enabled

ME Recovery Mode (JPME1)

Close pins 2-3 of JPME1 to enable ME Recovery Mode. See the table on the right for jumper settings.

JPME1 Jumper Settings	
Both Jumpers	Definition
Pins 1-2	Disabled
Pins 2-3	Enabled

A. ME Recovery Mode

B. ME Manufacturing Mode

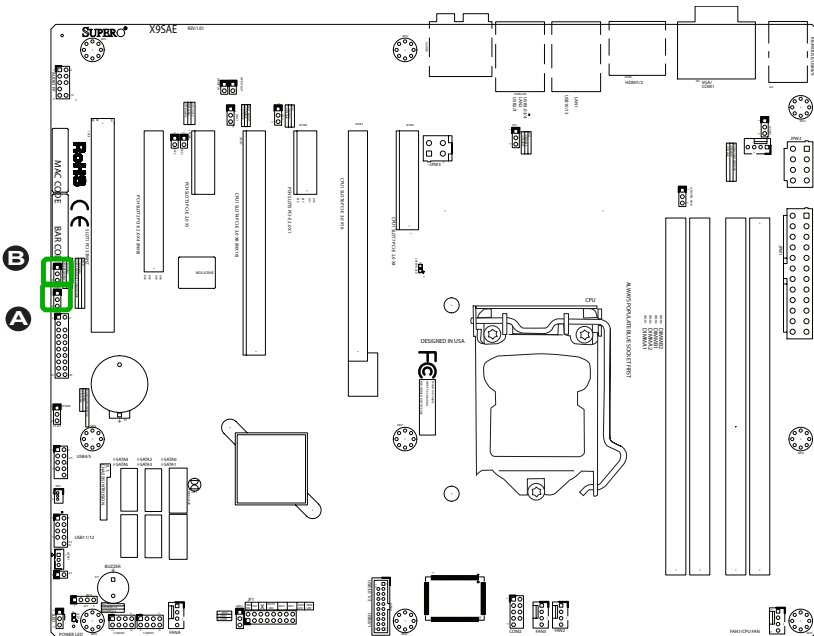

Audio Enable (JPAC1)

JPAC1 allows you to enable or disable the onboard audio support. The default position is on pins 1 and 2 to enable on-board audio connections. See the table on the right for jumper settings.

Audio Enable/Disable Jumper Settings	
Both Jumpers	Definition
Pins 1-2	Enabled
Pins 2-3	Disabled

Watch Dog Timer Reset (JWD1)

Watch Dog Timer Reset (JWD1) is a system monitor that can reboot the system when a software application hangs. Close Pins 1-2 to reset the system if an application hangs. Close Pins 2-3 to generate a non-maskable interrupt signal for the application that hangs. See the table on the right for jumper settings. Watch Dog must also be enabled in the BIOS.

Watch Dog Timer Reset Jumper Settings	
Jumper Setting	Definition
Pins 1-2	Reset (default)
Pins 2-3	NMI
Open	Disabled

A. Audio Enable

B. Watch Dog Timer Reset

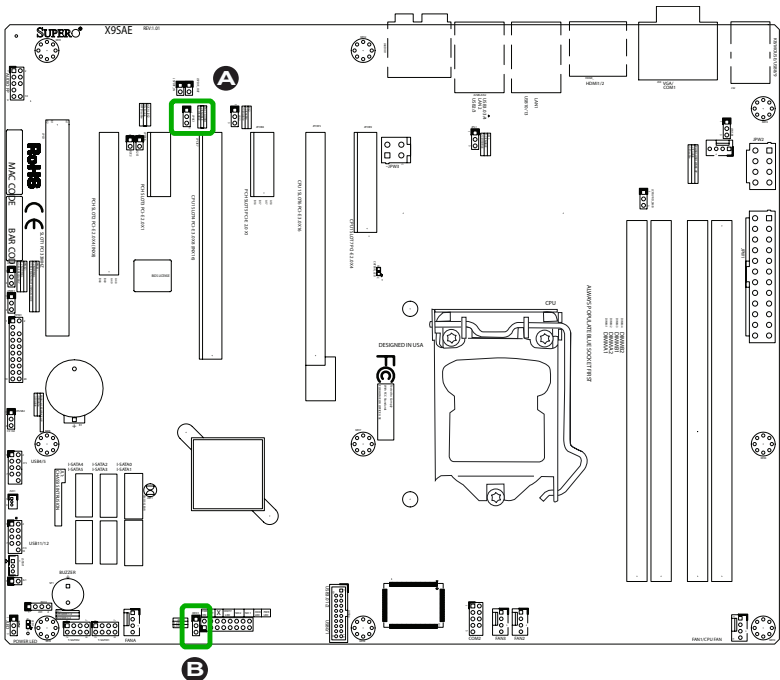

USB Wake-Up (JPUSB1/JUSB2)

Use the JPUSB jumpers to enable system "wake-up" via a USB device. These jumpers allow you to "wake-up" the system by pressing a key on the USB keyboard or by clicking the USB mouse of your system. The JPUSB jumpers are used together with the USB Wake-Up function in the BIOS. Enable both the jumper and the BIOS setting to activate this function. See the table on the right for jumper settings and jumper connections. Use JUSB1 for back panel USB ports and JUSB2 for front panel USB headers/ports.

USB Wake-Up Jumper Settings	
Jumper Setting	Definition
Pins 1-2	Enabled
Pins 2-3	Disabled (Default)

TPM Support Enable Jumper Settings	
Jumper Setting	Definition
1-2 (Default)	Enabled
2-3	Disabled

A. JUSB1

B. JUSB2

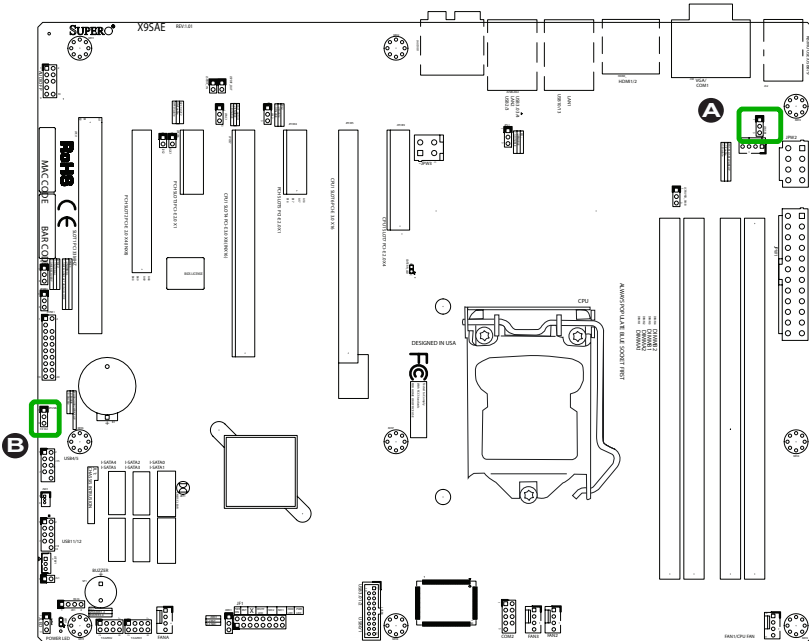

2-8 Onboard Indicators

LAN 1/LAN 2 LEDs

Two LAN ports (LAN 1/LAN 2) are located on the I/O back panel of the motherboard. Each Ethernet LAN port has two LEDs. The yellow LED indicates activity, while the Link LED may be green, amber, or off to indicate the speed of the connections. See the tables at right for more information.

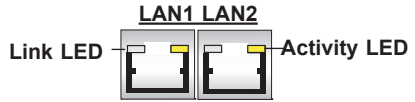

LAN 1/LAN 2 Link LEDs (Green/Amber/Off)	
LED Color	Definition
Off	No Connection or 10 Mbps
Green	100 Mbps
Amber	1 Gbps

Onboard Power LED (LED1)

An Onboard Power LED is located at LED1 on the motherboard. When LED1 is on, the AC power cable is connected. Make sure to disconnect the power cable before removing or installing any component. See the layout below for the LED location.

Onboard PWR LED Indicator LED Status	
Status	Definition
Off	System Off
On	System on, or System off and PWR Cable Connected

- A. LAN Port 1
- B. LAN Port 2
- C. PWR LED

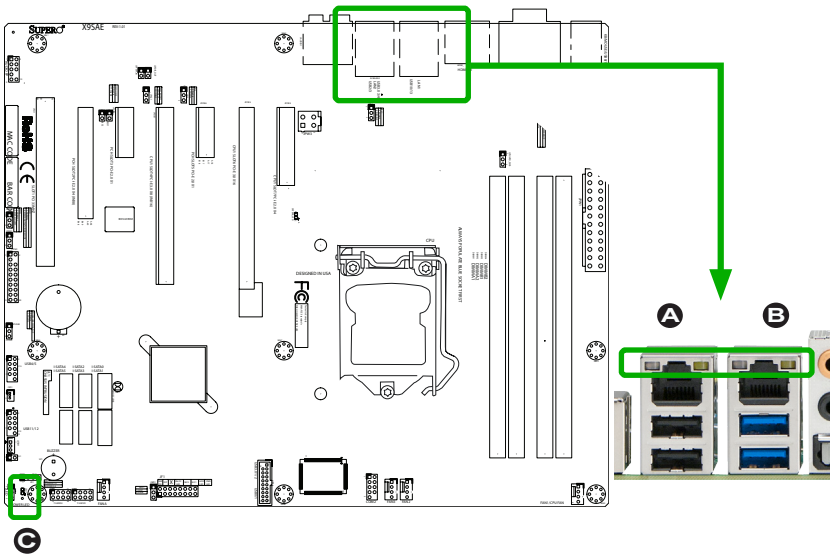

2-9 SATA Connections

SATA Connections (I-SATA0~I-SATA5)

Two 6Gb/s I-SATA 3.0 connectors (I-SATA 0/1) are located on the motherboard. In addition, four I-SATA 2.0 (I-SATA 2~5) connectors are also located on the board. The SATA 3.0 ports support RAID 0, 1 while the SATA 2.0 ports support RAID 0, 1, 5 & 10. See the table on the right for pin definitions.

X9SAE Motherboard Series SATA Connector Types	
Port#	Connection Type
I-SATA 0/1,	SATA 3.0
I-SATA 2/3/4/5	SATA 2.0

SATA 2.0/3.0 Connectors Pin Definitions	
Pin#	Signal
1	Ground
2	SATA_TXP
3	SATA_TXN
4	Ground
5	SATA_RXN
6	SATA_RXP
7	Ground

- A. I-SATA 3.0 #0
- B. I-SATA 3.0 #1
- C. I-SATA 2.0 #2
- D. I-SATA 2.0 #3
- E. I-SATA 2.0 #4
- F. I-SATA 2.0 #5

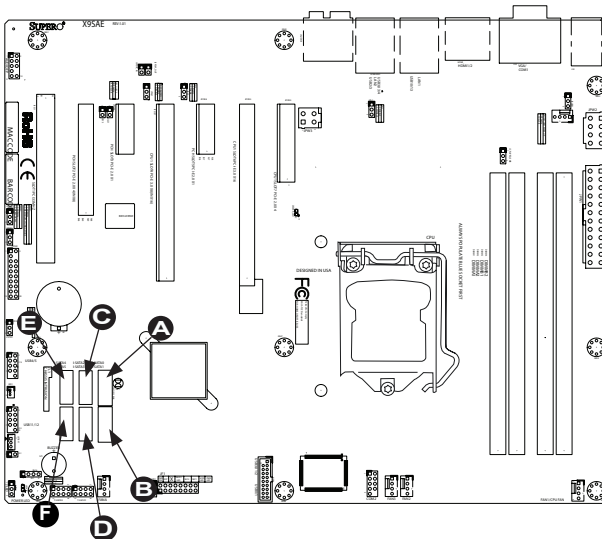

Chapter 3

Troubleshooting

3-1 Troubleshooting Procedures

Use the following procedures to troubleshoot your system. If you have followed all of the procedures below and still need assistance, refer to the 'Technical Support Procedures' and/or 'Returning Merchandise for Service' section(s) in this chapter. Always disconnect the AC power cord before adding, changing or installing any hardware components.

Before Power On

1. Make sure that the Standby PWR LED is not on. (**Note:** If it is on, the onboard power is on. Be sure to unplug the power cable before installing or removing the components.)
2. Make sure that there are no short circuits between the motherboard and chassis.
3. Disconnect all ribbon/wire cables from the motherboard, including those for the keyboard and mouse. Also, be sure to remove all add-on cards.
4. Install a CPU and heatsink (-be sure that it is fully seated) and then connect the chassis speaker and the power LED to the motherboard. Check all jumper settings as well.

No Power

1. Make sure that there are no short circuits between the motherboard and chassis.
2. Make sure that all jumpers are set to their default positions.
3. Check if the 115V/230V switch on the power supply is properly set.
4. Turn the power switch on and off to test the system.
5. The battery on your motherboard may be old. Check to make sure that it still supplies ~3VDC. If it does not, replace it with a new one.

No Video

1. If the power is on, but you have no video--in this case, you will need to remove all the add-on cards and cables first.
2. Use the speaker to determine if any beep codes exist. (Refer to Appendix A for details on beep codes.)
3. Remove all memory modules and turn on the system. (If the alarm is on, check the specs of memory modules, reset the memory or try a different one.)

Memory Errors

1. Make sure that the DIMM modules are properly installed and fully seated in the slots.
2. You should be using unbuffered ECC/Non-ECC DDR3 (1.5V) 1600/1333/1066 MHz memory (recommended by the manufacturer). Also, it is recommended that you use the memory modules of the same type and speed for all DIMMs in the system. Do not use memory modules of different sizes, different speeds and different types on the same motherboard.
3. Check for bad DIMM modules or slots by swapping modules between slots to see if you can locate the faulty ones.
4. Check the switch of 115V/230V power supply.

Losing the System's Setup Configuration

1. Please be sure to use a high quality power supply. A poor quality power supply may cause the system to lose CMOS setup information. Refer to Section 1-5 for details on recommended power supplies.
2. The battery on your motherboard may be old. Check to verify that it still supplies ~3VDC. If it does not, replace it with a new one.
3. If the above steps do not fix the Setup Configuration problem, contact your vendor for repairs.

3-2 Technical Support Procedures

Before contacting Technical Support, please make sure that you have followed all the steps listed below. Also, Note that as a motherboard manufacturer, Supermicro does not sell directly to end users, so it is best to first check with your distributor or reseller for troubleshooting services. They should know of any possible problem(s) with the specific system configuration that was sold to you.

1. Please go through the 'Troubleshooting Procedures' and 'Frequently Asked Question' (FAQ) sections in this chapter or see the FAQs on our website (<http://www.supermicro.com/support/faqs/>) before contacting Technical Support.
2. BIOS upgrades can be downloaded from our website at (<http://www.supermicro.com/support/bios/>).



Note: Not all BIOS can be flashed. Some cannot be flashed; it depends on the boot block code of the BIOS.

3. If you've followed the instructions above to troubleshoot your system, and still cannot resolve the problem, then contact Supermicro's technical support and provide them with the following information:
 - Motherboard model and PCB revision number
 - BIOS release date/version (this can be seen on the initial display when your system first boots up)
 - System configuration
 - An example of a Technical Support form is on our website at (<http://www.supermicro.com/support/contact.cfm>).
4. Distributors: For immediate assistance, please have your account number ready when placing a call to our technical support department. We can be reached by e-mail at support@supermicro.com, by phone at: (408) 503-8000, option 2, or by fax at (408)503-8019.

3-3 Frequently Asked Questions

Question: What type of memory does my motherboard support?

Answer: The X9SAE Motherboard Series supports up to 32GB of unbuffered ECC/ Non-ECC DDR3 (1.5V, 1600/1333/1066 MHz) memory. See Section 2-3 for details on installing memory.

Question: How do I update my BIOS?

Answer: We do NOT recommend that you upgrade your BIOS if you are not experiencing any problems with your system. Updated BIOS files are located on our website at <http://www.supermicro.com/support/bios/>. Please check our BIOS warning message and the information on how to update your BIOS on our web site. Select your motherboard model and download the BIOS ROM file to your computer. Also, check the current BIOS revision to make sure that it is newer than your BIOS before downloading. You may choose the zip file or the .exe file. If you choose the zipped BIOS file, please unzip the BIOS file onto a bootable device or a USB pen/thumb drive. To flash the BIOS, run the batch file named "ami.bat" with the new BIOS ROM file from your bootable device or USB pen/thumb drive. Use the following format:

```
F:\> ami.bat BIOS-ROM-filename.xxx <Enter>
```



Note: Always use the file named "ami.bat" to update the BIOS, and insert a space between "ami.bat" and the filename. The BIOS-ROM-filename will bear the motherboard name (i.e., X9SAE Motherboard Series) and build date as the extension. For example, "X9SAE Motherboard Series0.115". When completed, your system will automatically reboot.

If you choose the .exe file, please run the .exe file under Windows to create the BIOS flash floppy disk. Insert the floppy disk into the system you wish to flash the BIOS. Then, boot the system to the floppy disk. The BIOS utility will automatically flash the BIOS without any prompts. Please note that this process may take a few minutes to complete. Do not be concerned if the screen is paused for a few minutes.

When the BIOS flashing screen is completed, the system will reboot and will show "Press F1 or F2". At this point, you will need to load the BIOS defaults. Press <F1> to go to the BIOS setup screen, and press <F9> to load the default settings. Next, press <F10> to save and exit. The system will then reboot.



Caution: Do not shut down or reset the system while updating the BIOS to prevent possible system boot failure!



Important: The SPI BIOS chip installed on this motherboard is not removable. To repair or replace a damaged BIOS chip, please send your motherboard to RMA at Supermicro for service.

Question: I think my BIOS is corrupted. How can I recover my BIOS?

Answer: Please see Appendix C-BIOS Recovery for detailed instructions.

Question: What's on the CD that came with my motherboard?

Answer: The supplied compact disc has quite a few drivers and programs that will greatly enhance your system. We recommend that you review the CD and install the applications you need. Applications on the CD include chipset drivers for Windows, security programs, and audio drivers.

Question: Why do I get an error message "IASTOR.SYS read error" and "press F6 to install Intel RAID driver" when installing Windows on my motherboard?

Answer: To solve this issue, disable the IPMI jumper. Another solution is to use a USB floppy drive instead of the onboard floppy drive. For the IPMI jumper location, please check Chapter 1.

Question: What is the heatsink part number for my X9SAE Motherboard Series motherboard?

Answer: For the 1U passive heatsink, ask for SNK-P0046P (back plate is included). For the 2U active heatsink, use SNK-P0046A4.

Question: Why can't I recover the BIOS even when I've followed the instructions in the user's manual for the motherboard?

Answer: Please disable the IPMI jumper and try it again. For the jumper location, please check Chapter 1.

3-4 Battery Removal and Installation

Battery Removal

To remove the onboard battery, follow the steps below:

1. Power off your system and unplug your power cable.
2. Locate the onboard battery as shown below.

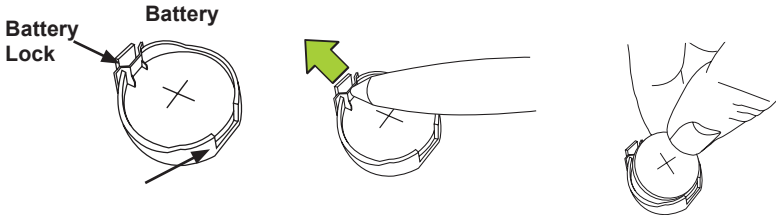

3. Using a tool such as a pen or a small screwdriver, push the battery lock outwards to unlock it. Once unlocked, the battery will pop out from the holder.
4. Remove the battery.

Proper Battery Disposal



Caution! Please handle used batteries carefully. Do not damage the battery in any way; a damaged battery may release hazardous materials into the environment. Do not discard a used battery in the garbage or a public landfill. Please comply with the regulations set up by your local hazardous waste management agency to dispose of your used battery properly.

Battery Installation

1. To install an onboard battery, follow the steps 1 & 2 above and continue below:
2. Identify the battery's polarity. The positive (+) side should be facing up.
3. Insert the battery into the battery holder and push it down until you hear a click to ensure that the battery is securely locked.



Caution: When replacing a battery, be sure to only replace it with the same type.

Battery Holder

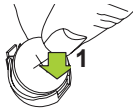
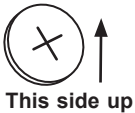

3-5 Returning Merchandise for Service

A receipt or copy of your invoice marked with the date of purchase is required before any warranty service will be rendered. You can obtain service by calling your vendor for a Returned Merchandise Authorization (RMA) number. For faster service, you may also obtain RMA authorizations online (<http://www.supermicro.com/support/rma/>). When you return the motherboard to the manufacturer, the RMA number should be prominently displayed on the outside of the shipping carton, and mailed prepaid or hand-carried. Shipping and handling charges will be applied for all orders that must be mailed when service is complete.

This warranty only covers normal consumer use and does not cover damages incurred in shipping or from failure due to the alteration, misuse, abuse or improper maintenance of products.

During the warranty period, contact your distributor first for any product problems.

Notes

Chapter 4

BIOS

4-1 Introduction

This chapter describes the AMI BIOS Setup Utility for the X9SAE Motherboard Series. The ROM BIOS is stored in a Flash EEPROM and can be easily updated. This chapter describes the basic navigation of the AMI BIOS Setup Utility setup screens.



Note: For AMI BIOS Recovery, please refer to the UEFI BIOS Recovery Instructions in Appendix C.

Starting BIOS Setup Utility

To enter the AMI BIOS Setup Utility screens, press the <Delete> key while the system is booting up.



Note: In most cases, the <Delete> key is used to invoke the AMI BIOS setup screen. There are a few cases when other keys are used, such as <F1>, <F2>, etc.

Each main BIOS menu option is described in this manual. The Main BIOS setup menu screen has two main frames. The left frame displays all the options that can be configured. Grayed-out options cannot be configured. Options in blue can be configured by the user. The right frame displays the key legend. Above the key legend is an area reserved for a text message. When an option is selected in the left frame, it is highlighted in white. Often a text message will accompany it. (**Note:** the AMI BIOS has default text messages built in. Supermicro retains the option to include, omit, or change any of these text messages.)

The AMI BIOS Setup Utility uses a key-based navigation system called "hot keys". Most of the AMI BIOS setup utility "hot keys" can be used at any time during the setup navigation process. These keys include <F1>, <F10>, <Enter>, <ESC>, arrow keys, etc.



Note: Options printed in **Bold** are default settings.

How To Change the Configuration Data

The configuration data that determines the system parameters may be changed by entering the AMI BIOS Setup utility. This Setup utility can be accessed by pressing at the appropriate time during system boot.

How to Start the Setup Utility

Normally, the only visible Power-On Self-Test (POST) routine is the memory test. As the memory is being tested, press the <Delete> key to enter the main menu of the AMI BIOS Setup Utility. From the main menu, you can access the other setup screens. An AMI BIOS identification string is displayed at the left bottom corner of the screen, below the copyright message.



Warning! Do not upgrade the BIOS unless your system has a BIOS-related issue. Flashing the wrong BIOS can cause irreparable damage to the system. In no event shall Supermicro be liable for direct, indirect, special, incidental, or consequential damages arising from a BIOS update. If you have to update the BIOS, do not shut down or reset the system while the BIOS is updating. This is to avoid possible boot failure.

4-2 Main Setup

When you first enter the AMI BIOS Setup Utility, you will enter the Main setup screen. You can always return to the Main setup screen by selecting the Main tab on the top of the screen. The Main BIOS Setup screen is shown below.

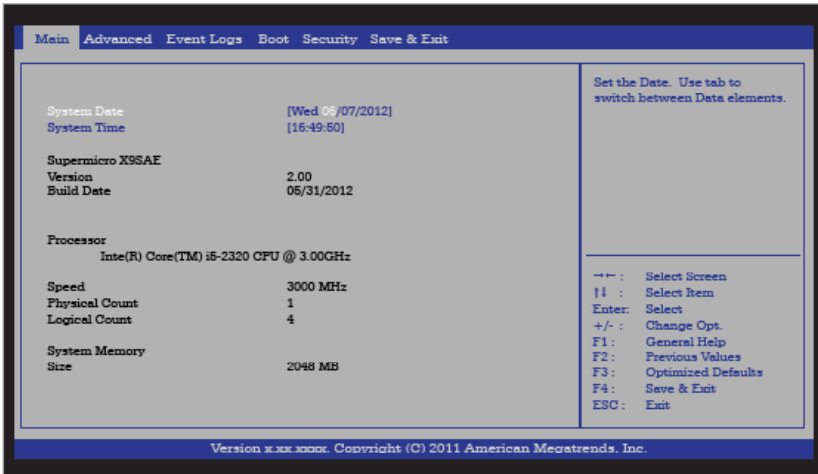

System Overview: The following BIOS information will be displayed:

System Time/System Date

Use this option to change the system time and date. Highlight *System Time* or *System Date* using the arrow keys. Enter new values through the keyboard. Press the <Tab> key or the arrow keys to move between fields. The date must be entered in Day MM/DD/YY format. The time is entered in HH:MM:SS format.



Note: The time is in the 24-hour format. For example, 5:30 P.M. appears as 17:30:00.

The following BIOS items will also be displayed:

Supermicro X9SAE

Version

Build Date

The AMI BIOS will automatically display the status of the processor used in the motherboard as shown below:

Processor

Speed

Physical Count

Logical Count

System Memory

This displays the size of memory available in the system:

Size

4-3 Advanced Setup Configurations

Use the arrow keys to select Boot Setup and press <Enter> to access the submenu items:

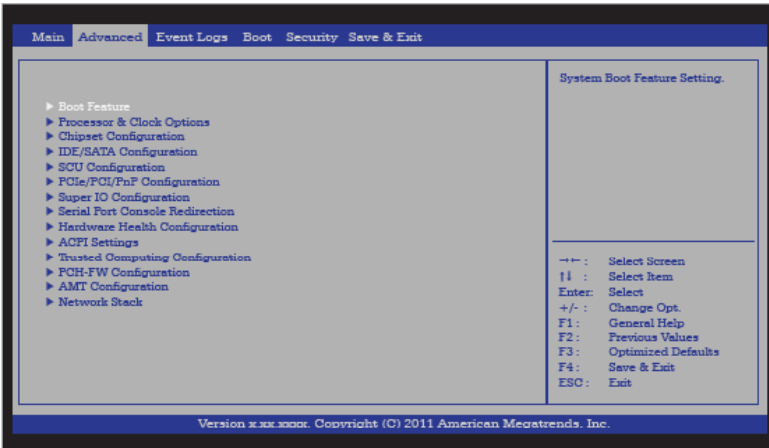

► Boot Feature

Quiet Boot

Use this feature to select the screen display between POST messages or the OEM logo at bootup. Select Disabled to display the POST messages. Select Enabled to display the OEM logo instead of the normal POST messages. The options are **Enabled** and Disabled.

AddOn ROM Display Mode

Use this feature to set the display mode for Option ROM. The options are **Force BIOS** and Keep Current.

Bootup Num-Lock

This feature selects the Power-on state for the Numlock key. The options are Off and **On**.

Wait For 'F1' If Error

This forces the system to wait until the 'F1' key is pressed if an error occurs. The options are Disabled and **Enabled**.

Interrupt 19 Capture

Interrupt 19 is the software interrupt that handles the boot disk function. When this item is set to Enabled, the ROM BIOS of the host adaptors will "capture" Interrupt 19 at bootup and allow the drives that are attached to these host adaptors to function

as bootable disks. If this item is set to Disabled, the ROM BIOS of the host adaptors will not capture Interrupt 19, and the drives attached to these adaptors will not function as bootable devices. The options are **Enabled** and Disabled.

►Power Configuration

Watch Dog Function

If enabled, the Watch Dog Timer will allow the system to reboot when it is inactive for more than 5 minutes. The options are Enabled and **Disabled**.

Power Button Function

This feature controls how the system shuts down when the power button is pressed. Select 4_Seconds_Override for the user to power off the system after pressing and holding the power button for 4 seconds or longer. Select Instant Off to instantly power off the system as soon as the user presses the power button. The options are 4 Second Override and **Instant Off**.

Restore on AC Power Loss

Use this feature to set the power state after a power outage. Select Power-Off for the system power to remain off after a power loss. Select Power-On for the system power to be turned on after a power loss. Select Last State to allow the system to resume its last power state before a power loss. The options are Power-On, Power-Off and **Last State**.

Deep Sx Power Policies

Select Enabled to enable Deep Sleep State support. The settings are Enabled and **Disabled**.

►Processor & Clock Options



Warning: Take Caution when changing the Advanced settings. An incorrect value, a very high DRAM frequency or an incorrect DRAM timing setting may cause system to become unstable. When this occurs, revert to the setting to its manufacture default setting.

Clock Spread Spectrum

If Enabled, the BIOS will monitor the level of Electromagnetic Interference caused by the components and will attempt to decrease the interference whenever needed. The options are Enabled and **Disabled**.

Hardware Prefetcher (Available when supported by the CPU)

If set to Enabled, the hardware prefetcher will prefetch streams of data and instructions from the main memory to the L2 cache to improve CPU performance. The options are Disabled and **Enabled**.

Adjacent Cache Line Prefetch (Available when supported by the CPU)

Select Enabled for the CPU to prefetch both cache lines for 128 bytes as comprised. Select Disabled for the CPU to prefetch both cache lines for 64 bytes. The options are Disabled and **Enabled**.

Intel[®] Virtualization Technology (Available when supported by the CPU)

Select Enabled to use the Intel Virtualization Technology to allow one platform to run multiple operating systems and applications in independent partitions, creating multiple "virtual" systems in one physical computer. The options are **Enabled** and Disabled.



Note: If there is any change to this setting, you will need to power off and restart the system for the change to take effect. Please refer to Intel's web site for detailed information.

Execute-Disable Bit Capability (Available when supported by the OS and the CPU)

Set to Enabled to enable the Execute Disable Bit which will allow the processor to designate areas in the system memory where an application code can execute and where it cannot, thus preventing a worm or a virus from flooding illegal codes to overwhelm the processor or damage the system during an attack. The default is **Enabled**. (Refer to Intel and Microsoft Web Sites for more information.)

Intel[®] AES-NI

This feature enables or disables the processor's Advanced Encryption Standard support. The options are **Disabled** and Enabled.

Active Processor Cores

Enables selection of the number of the processor's core to activate. (Please refer to Intel's web site for more information.) The options are **All**, 1, 2, 3 and 4.

Power Technology

Use this feature to select a power-saving scheme for the motherboard. The options are Disabled, **Energy Efficient** and Custom. If Custom is selected, the following options become available:

►Turbo Boost Technology (Available when Intel® EIST technology is Enabled)

This feature allows processor cores to run faster than marked frequency in specific conditions.

Turbo Mode

This feature allows processor cores to run faster than marked frequency in specific conditions. The options are Disabled and **Enabled**.

Factory Long Duration Power Limit

This feature displays the value of the processor power consumption limit (in Watts) set by the manufacturer for a long duration time window.

Long Duration Power Limit

Use this feature to set the processor power consumption limit (in Watts) value for a long duration time window.

Factory Long Duration Maintained

This feature displays the manufacture-preset time value in milliseconds when the Long Duration Power Limit is maintained.

Long Duration Maintained

Use this feature to set the time value when the Long Duration Power Limit is maintained.

Recommended Short Duration Power Limit

The system's power consumption may exceed the processor's default power setting and the Short Duration Power Limit when operating in the turbo mode. This feature displays the Short Duration Power Limit value recommended by the manufacturer for turbo mode operation. By increasing this value, the processor can provide better performance for a short duration operation. The default setting is **1.25* Long Duration** (that means, 1.25 times the value of Long Duration Power Limit indicated above.)

Short duration power limit

The system's power consumption may exceed the processor's default power setting and the Short Duration Power Limit when operating in the turbo mode. By increasing this value, the processor can provide better performance for a short duration operation.

Chipset Configuration

WARNING: Setting the wrong values in the following sections may cause the system to malfunction.

►CPU Bridge Configuration

This item displays the current CPU Revision, Current CPU1 Memory Frequency, Memory Type and Memory Reference Code Revision.

Memory Frequency

This feature allows the user to select the memory speed. Under normal conditions, please set this to Auto. The options are **Auto**, Force DDR-1066, and Force DDR-1333.

►Integrated IO Configuration

This item displays the current North Bridge Revision.

VT-d

Select Enabled to enable Intel's Virtualization Technology support for Direct I/O VT-d by reporting the I/O device assignments to VMM through the DMAR ACPI Tables. This feature offers fully-protected I/O resource-sharing across the Intel platforms, providing the user with greater reliability, security and availability in networking and data-sharing. The settings are Enabled and **Disabled**.

Active State Power Management

Select Enabled to start Active-State Power Management for signal transactions between L0 and L1 Links on the PCI Express Bus. This maximizes power-saving and transaction speed. The options are Enabled and **Disabled**.

PCIe Maximum Read Request

This feature selects the setting for the PCIe maximum payload size. The options are **Auto**, 128 Bytes, 256 Bytes, 512 Bytes, 1024 Bytes, 2048 Bytes, and 4096 Bytes.

PCI Express Port

This feature can force to enable or disable the onboard PCI Express port. The options are Disabled, Enabled and **Auto**.

PCI Express Port - Gen X

This feature forces Gen1 or Gen2 support on the PCI Express Graphics (PEG) port. The options are **Auto**, Gen1 and Gen2.

De-emphasis Control

This feature configures de-emphasis control on the PEG port. The options are **-3.5 dB**, and -6 dB.

The following options are available if the CPU supports and Integrated Graphics Device (IGD).

Aperture Size

This feature selects the Aperture Size. The options are Disabled, 128MB, **256MB** and 512M.

DVMT Pre-Allocated

This feature selects the pre-allocated fixed memory size for the Integrated Graphics Device (IGD). The options are Disabled, 32M, **64M**, 96M, 128M, 160M, 192M, 224M, 256M, 288M, 320M, 352M, 384M, 416M, 448M, 480M, 512M and 1024M.

DVMT Total Gfx Mem

This feature selects the total memory size for the Integrated Graphics Device (IGD). The options are 128M, **256M**, and MAX.

Gfx Low Power Mode

This feature enables low power mode for the Gfx. Applicable for SFF only. The options are **Enabled** and Disabled.

Graphics Performance Analyzers

This feature enables or disables the Intel Graphics Performance Analyzer counters. The options are Enabled and **Disabled**.

►GT - Power Management Control

These options appear only if the CPU supports IGD:

RC6 (Render Standby)

This feature enables or disables render standby by the Internal Graphics Device (IGD). The options are Disabled and **Enabled**.

RC6+ (Deep RC6)

This item enables or disables Deep RC6 (RC6+) support by the Internal Graphics Device (IGD). The options are Disabled and **Enabled**.

GT OverClocking Support

This item enables or disables GT over clocking support by the Internal Graphics Device (IGD). The options are **Disabled** and Enabled.

►South Bridge Configuration

This item displays the current South Bridge configuration.

USB Functions

This feature will enable or disable the motherboard's USB functions. The options are **Enabled** and Disabled.

USB 3.0 Functions

This feature will enable or disable the motherboard's USB 3.0 functions. The options are **Enabled** and Disabled.

Legacy USB Support

This feature enables support for legacy USB devices. Select Auto to disable legacy support if USB devices are not present. Select Disable to have USB devices available only for EFI applications. The options are **Enabled**, Disabled and Auto.

Port 60/64 Emulation

This feature enables or disables I/O port 60h/64h emulation support. This should be enabled for complete USB keyboard legacy support for non-USB-aware Operating Systems. The options are Disabled and **Enabled**.

BIOS EHCI Hand-Off

This item is for Operating Systems that does not support Enhanced Host Controller Interface (EHCI) hand-off. When enabled, EHCI ownership change will be claimed by the EHCI driver. The settings are **Enabled** and Disabled.

XHCI Hand-off

Select Enabled for Operating Systems without XHCI hand-off support. The XHCI ownership change will be claimed by the XHCI driver. The settings are **Enabled** and Disabled.

Azalia HD Audio (available if JPAC1 jumper is enabled)

This feature enables or disables the motherboard's built-in High Definition (HD) audio. The options are **Enabled** and Disabled.

Frontside Audio Mode (available if Azalia HD Audio is enabled)

This feature selects between AC'97 legacy audio and HD audio. The options are **HD Audio** and AC'97.

►IDE/SATA Configuration

When this submenu is selected, the AMI BIOS automatically detects the presence of the IDE Devices and displays the following items:

SATA Mode

This item selects the mode for the installed drives. The options are Disabled, IDE Mode, **AHCI Mode** and RAID Mode.

AHCI Mode

The following items are displayed when AHCI Mode is selected:

Aggressive LPM Support

This feature Enables or Disables Aggressive Link Power Management support for Cougar Point B0 stepping and later. The options are **Enabled** and Disabled.

SATA Port0~Port5

This item displays the information detected on the installed SATA drives on the particular SATA port.

Hot Plug

Set this item to Enabled to enable hot-plugging. The options are Enabled and **Disabled**.

Staggered Spin Up

Set this item to Enabled to enable Staggered Spin-up support. The options are Enabled and **Disabled**.

IDE Mode

The following items are displayed when IDE Mode is selected:

IDE Legacy / Native Mode Selection

This feature enables support for either legacy or native mode. The options are **Native** and Legacy.

SATA Port0~Port5

This item displays the information detected on the installed SATA drives on the particular SATA port.

RAID Mode

The following items are displayed when RAID Mode is selected:

SATA Port0~Port5

This item displays the information detected on the installed SATA drives on the particular SATA port.

Hot Plug

Set this item to Enabled to enable hot-plugging. The options are Enabled and **Disabled**.

►PCIe/PCI/PnP Configuration

This feature allows the user to set the PCI/PnP configurations for the following items:

PCI Latency Timer

This feature sets the latency Timer of each PCI device installed on a PCI bus. Select 64 to set the PCI latency to 64 PCI bus clock cycles. The options are 32 PCI Bus Clocks, **64 PCI Bus Clocks**, 96 PCI Bus Clocks, 128 PCI Bus Clocks, 160 PCI Bus Clocks, 192 PCI Bus Clocks, 224 PCI Bus Clocks and 248 PCI Bus Clocks.

Above 4G Decoding

Select Enabled to activate 64-bit capable devices to be decoded above the 4G address space (only if the system supports 64-bit PCI decoding). The options are **Disabled** and Enabled.

PERR# Generation

PERR (Parity Error) is for reporting address parity errors. It is shared among all PCI devices. The options are Disabled and **Enabled**.

SERR# Generation

SERR (System Error) is for reporting system errors, or any other fatal system errors. It is shared among all PCI devices. The options are Disabled and Enabled.

PCI-E Slot 5 OPROM

Use this feature to enable or disable PCI-E Slot 5 slot Option ROM. The options are Disabled and **Enabled**.

Onboard LAN Option ROM Select

Use this feature to select which option ROM the system will use. The options are **PXE**, and **iSCSI**.

Onboard LAN1/LAN2 Option ROM

This feature enables or disables the onboard ROM option for LAN1 and LAN2. The options are **Disabled** and **Enabled**.

Boot Graphics Adapter Priority

Use the feature to select the graphics controller to be used as the primary boot device. The options are Slot 6 VGA, **Offboard**, and **Onboard**.

► Super IO Configuration

Serial Port 1 / Serial Port 2

Select **Enabled** to enable the onboard serial port. The options are **Enabled** and **Disabled**.

Serial Port 1 / Serial Port 2 Settings

This option specifies the base I/O port address and the Interrupt Request address of Serial Port 1 ~ 2. Select **Auto** to let the BIOS automatically assign the base I/O and IRQ address.

The options for Serial Port 1 are

Auto,

IO=3F8h; IRQ=4,

IO=3F8h; IRQ=3 through IRQ=12,

IO=2F8h; IRQ=3 through IRQ=12,

IO=3E8h; IRQ=3, through IRQ=12)

and

IO=2E8h; IRQ=3 through IRQ=12).

The options for Serial Port 2 are

Auto,

IO=2F8h; IRQ=3,

IO=3F8h; IRQ=3 through IRQ=12,

IO=2F8h; IRQ=3 through IRQ=12,

IO=3E8h; IRQ=3, through IRQ=12)

and

IO=2E8h; IRQ=3 through IRQ=12).

► Serial Port Console Redirection

COM1/COM2 Console Redirection

Use this feature to enable console redirection for COM1 and COM2 ports. The options are Enabled and **Disabled**.

► Console Redirection Settings

Configure the following options for the Console Redirection Settings. The most common settings are set as default:

Terminal Type : Select ANSI, VT100, **VT100+**, or VT-UTF8

Bits per Second (BPS): 9600, 19200, 38400, 57600, or **115200**

Data Bits: **8** or 7

Parity: **None**, Even, Odd, Mark, or Space

Stop Bits: **1** or 2

Flow Control: **None** or Hardware RTS/CTS

VT-UTF8 Combo Key Support: **Enabled** or Disabled

Recorder Mode: **Disabled** or Enabled

Resolution 100x31: **Enabled** or Disabled

Legacy OS Redirection Resolution: **80x25** or 80x24

puTTY Keypad: **VT100**, LINUX, XTERM6, SCO,ESCN, VT400

Serial Port for Out-of-Band Management/ Windows Emergency Management Services (EMS)

Use this feature to enable console redirection for Serial Port for Out-of-Band Management and Windows Emergency Management Services (EMS). The options are Enabled and **Disabled**.

► Console Redirection Settings

Configure the following options for the Console Redirection Settings. The most common settings are set as default:

Out-of-Band Mgmt Port: **COM1**, COM2, COM3 (PCI, Bus0, Dev0, Func0)

Terminal Type : Select ANSI, VT100, VT100+, or **VT-UTF8**

Bits per Second (BPS): 9600, 19200, 57600, or **115200**

Data Bits: **8** or 7

Parity: **None**, Even, Odd, Mark, or Space

Stop Bits: **1** or 2

►Hardware Health Configuration

Fan Speed Control Mode

This feature allows the user to decide how the system controls the speeds of the onboard fans. The CPU temperature and the fan speed are correlative. When the CPU on-die temperature increases, the fan speed will also increase for effective system cooling. Select "Full Speed" to allow the onboard fans to run at full speed (of 100% Pulse Width Modulation Duty Cycle) for maximum cooling. This setting is recommended for special system configuration or debugging. Select "Standard" for the onboard fans to run at 50% of the Initial PWM Cycle in order to balance the needs between system cooling and power saving. This setting is recommended for regular systems with normal hardware configurations. The options are Full Speed, **Standard**, and Optimal.

CPU Temperature

This feature displays the CPU temperature status in text ("Low", "Medium" or "High"):

Low – This level is considered as the 'normal' operating state. The CPU temperature is well below the CPU 'Temperature Tolerance'. The motherboard fans and CPU will run normally as configured in the BIOS (Fan Speed Control).

User intervention: No action required.

Medium – The processor is running warmer. This is a 'precautionary' level and generally means that there may be factors contributing to this condition, but the CPU is still within its normal operating state and below the CPU 'Temperature Tolerance'. The motherboard fans and CPU will run normally as configured in the BIOS. The fans may adjust to a faster speed depending on the Fan Speed Control settings.

User intervention: No action is required. However, consider checking the CPU fans and the chassis ventilation for blockage.

High – The processor is running hot. This is a 'caution' level since the CPU's 'Temperature Tolerance' has been reached (or has been exceeded) and may activate an overheat alarm:

The information provided above is for your reference only. For more information on thermal management, please refer to Intel's Web site at www.Intel.com.

System Temperature / Peripheral Temperature / PCH Temperature

This feature displays the temperature readings from the system sensor (chassis) and peripheral devices.

Fan 1 ~ Fan 4, Fan A Reading

This feature displays the fan speed readings from fan interfaces Fan1 through Fan4 and Fan A.

VCORE, 12V, VDIMM, 5VCC, VTT, AVCC, 3.3VCC, VSB, VBAT

This feature displays the current voltages of the above voltage monitors.

►ACPI Settings

Use this feature to configure Advanced Configuration and Power Interface (ACPI) power management settings for your system.

High Precision Event Timers

Select Enabled to activate the High Performance Event Timer (HPET) that produces periodic interrupts at a much higher frequency than a Real-time Clock (RTC) does in synchronizing multimedia streams, providing smooth playback and reducing the dependency on other timestamp calculation devices, such as an x86 RDTSC Instruction embedded in the CPU. The High Performance Event Timer is used to replace the 8254 Programmable Interval Timer. The options are **Enabled** and Disabled.

Suspend Mode

This setting allows you to configure the ACPI (Advanced Configuration and Power Interface) sleep state for your system when it is in the Suspend mode. The options are Suspend Disabled, and **S3 (STR)**. S3 (STR) is the deepest sleep state in these options.

WHEA Support

This feature Enables the Windows Hardware Error Architecture (WHEA) support for the Windows 2008 operating system (and later versions). The options are **Enabled** and Disabled.

►Trusted Computing Configuration

TPM Support

This feature enables or disables the BIOS TPM support. The options are Disable and **Enable**. Note that the OS will not reveal the security device.

►Intel TXT(LT) Configuration

Secure Mode Extensions (SMX)

This feature can be configured if it is supported by the processor. Enable this feature to activate Intel TXT, below. The options are Enabled and **Disabled**.

Intel TXT (LT) Support

Intel TXT (Trusted Execution Technology) helps protect against software-based attacks and ensures protection, confidentiality and integrity of data stored or created on the system. The options are Enabled and **Disabled**.

►PCH-FW Configuration

This option displays Management Engine information and configurable features.

►Firmware Update Configuration

This option enables or disables the Management Engine firmware image re-flash function. The options are Enabled and **Disabled**.

►AMT Configuration

Intel AMT

This option enables Intel AMT support. The options are **Enabled** and Disabled.

BIOS Hotkey Pressed

This option enables or disables the BIOS Hotkey. The options are Enabled and **Disabled**.

MEBx Selection Screen

This option enables or disables the MEBx selection screen. The options are Enabled and **Disabled**.

Hide Un-configure ME Confirmation Prompt

This option enables or disables the "Un-configure ME" confirmation prompt. The options are Enabled and **Disabled**.

MEBx Debug Message Output

This option enables or disables the MEBx Debug Message Output. The options are Enabled and **Disabled**.

Un-Configure ME

This option allows the option to Un-Configure ME without a password. The options are Enabled and **Disabled**.

AMT Wait Timer

This option specifies a set time (in seconds) to wait before sending "ASF_GET_BOOT_OPTIONS". The default is **0**. Enter any whole number greater than 0 to activate.

Disable ME

This option temporarily sets the Management Engine to soft disable. The options are Enabled and **Disabled**.

ASF

This option enables or disables Alert Specification Format. The options are **Enabled** and Disabled.

Activate Remote Assistance Process

This option enables or disables the Remote Assistance Process (triggers CIRA boot). The options are Enabled and **Disabled**.

USB Configure

This option enables or disables the USB configuration function. The options are **Enabled** and Disabled.

PET Progress

This option enables or disables PET Events Progress to receive PET events. The options are **Enabled** and Disabled.

Watch Dog Timer

Allows AMT to reset or power down the system if the operating system or BIOS hangs or crashes. The options are **Disabled**, and Enabled.

OS WatchDog Timer / BIOS WatchDog Timer

These options appear if Watch Dog Timer (above) is enabled. This is a timed delay in seconds, before a system power down or reset after a BIOS or operating system failure is detected. Directly enter the value, in seconds.

►Network Stack

Set this item to Enabled to activate the Network Stack (PXE and UEFI). The options are Enable and **Disable Link**. When enabled, the following options appear:

Ipv4 PXE Support

This feature enables Ipv4 boot support. If disabled, an Ipv4 PXE boot option will not be created. The options are **Enable** and Disable Link.

Ipv6 PXE Support

This feature enables Ipv6 boot support. If disabled, an Ipv6 PXE boot option will not be created. The options are **Enable** and Disable Link.

4-4 Event Logs

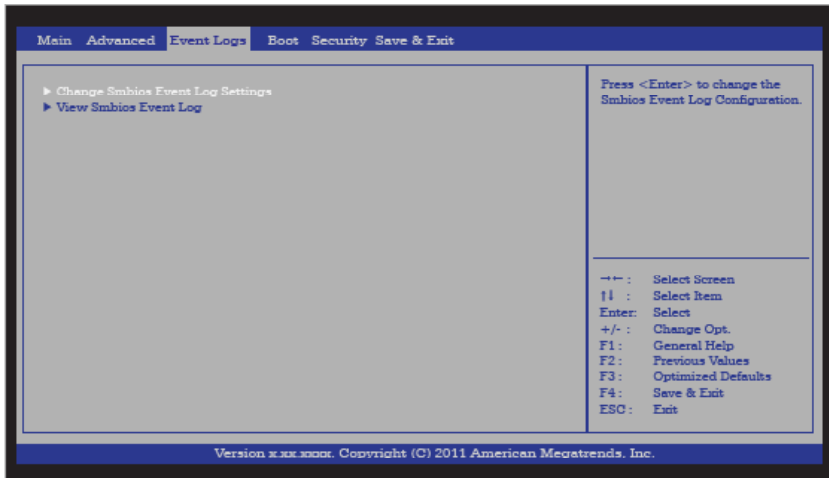

►Change SmbIOS Event Log Settings

Smbios Event Log

Change this item to enable or disable all features of the SmbIOS Event Logging during boot. The options are **Enabled** and Disabled.

Erase Settings

Erase Event Log

This option erases all logged events. The options are **No**, Yes, Next reset and Yes, Every reset.

When Log is Full

This option automatically clears the Event Log memory of all messages when it is full. The options are **Do Nothing** and Erase Immediately.

SmbIOS Event Log Standard Settings

Log System Boot Event

This option toggles the System Boot Event logging to enabled or disabled. The options are **Disabled** and Enabled.

MECI

The Multiple Event Count Increment (MECI) counter counts the number of times a duplicate event must happen before the MECI counter is incremented. This is a numeric value. The default value is **1**.

METW

The Multiple Event Time Window (METW) defines number of minutes must pass between duplicate log events before MECI is incremented. This is in minutes, from 0 to 99. The default value is **60**.

View SmbIOS Event Log

This feature displays the contents of the SmbIOS Event Log.

4-5 Boot Settings



Setup Prompt Timeout

Number of seconds to wait for setup activation key. Enter 65535 (0xFFFF) to wait indefinitely.

Retry Boot Devices

This item will force the BIOS to continuously retry to boot from legacy devices. The options are **Disabled** and Enabled.

Boot Option Filter

This item selects which set of devices the BIOS boots from. The options are **UEFI and Legacy**, Legacy Only and UEFI Only.

Boot Option #1, #2, #3, ...

This item determines from the installed boot devices, the order where the BIOS boots from. The options are **UEFI: Built-n EFI Shell**, [other detected devices], and Disabled.

Network Device BBS Priorities, CD/DVD ROM Drive BBS Priorities, Hard Drive BBS Priorities,

These options appear only if any of the devices are installed and detected by the BIOS. This feature sets the order of legacy devices in their particular groups. The boot options are dependent on what devices are installed in the system.

4-6 Security Settings

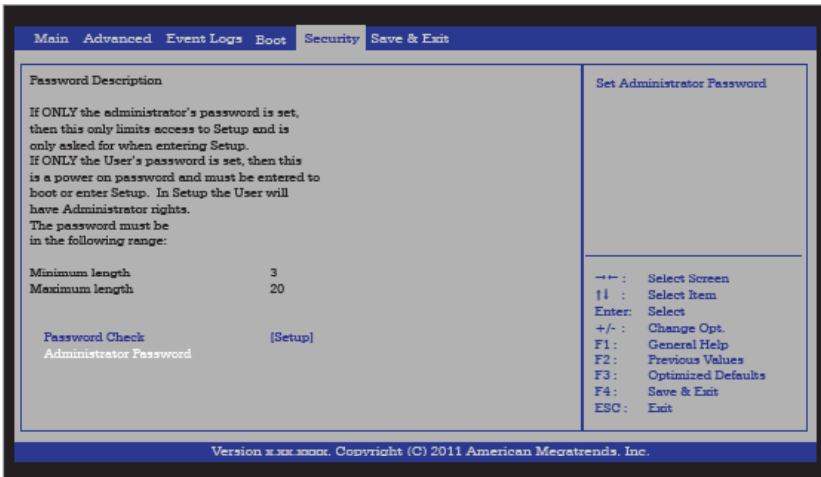

- Passwords must be at least 3 and up to 20 characters long.

Password Check

This option activates a password prompt everytime the system boots or only during BIOS setup. The options are **Setup** and Always.

Administrator Password

Press Enter to create a new, or change an existing Administrator password. If Administrator Password is defined, the following will appear:

User Password:

Press Enter to create a new, or change an existing User password.

4-7 Save & Exit Options

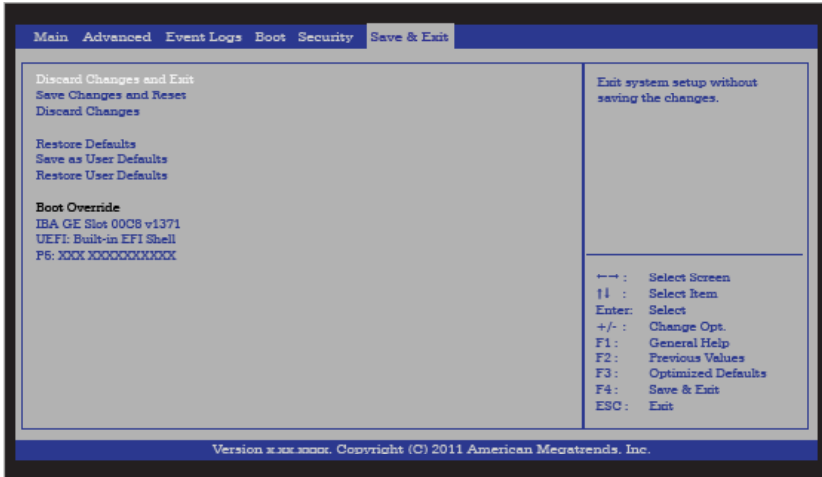

Discard Changes and Exit

Select this option to quit the BIOS Setup without making any permanent changes to the system configuration, and reboot the computer. Select Discard Changes and Exit from the Exit menu and press <Enter>.

Save Changes and Reset

When you have completed the system configuration changes, select this option to leave the BIOS Setup Utility and reboot the computer, so the new system configuration parameters can take effect. Select Save Changes and Exit from the Exit menu and press <Enter>.

Discard Changes

Select this option and press <Enter> to discard all the changes and return to the AMI BIOS Utility Program.

Restore Defaults

To set this feature, select Restore Defaults from the Exit menu and press <Enter>. These are factory settings designed for maximum system stability, but not for maximum performance.

Save As User Defaults

To set this feature, select Save as User Defaults from the Exit menu and press <Enter>. This enables the user to save any changes to the BIOS setup for future use

Restore User Defaults

To set this feature, select Restore User Defaults from the Exit menu and press <Enter>. Use this feature to retrieve user-defined settings that were saved previously.

Boot Override

Set this feature to override a previously defined boot device. The available devices will be listed below.

Appendix A

BIOS Error Beep Codes

During the POST (Power-On Self-Test) routines, which are performed each time the system is powered on, errors may occur.

Non-fatal errors are those which, in most cases, allow the system to continue with bootup. The error messages normally appear on the screen.

Fatal errors will not allow the system to continue to bootup. If a fatal error occurs, you should consult with your system manufacturer for possible repairs.

These fatal errors are usually communicated through a series of audible beeps. The numbers on the fatal error list correspond to the number of beeps for the corresponding error.

A-1 BIOS Error Beep Codes

BIOS Error Beep Codes		
Beep Code/LED	Error Message	Description
1 beep	Refresh	Circuits have been reset. (Ready to power up)
5 short beeps + 1 long beep	Memory error	No memory detected in the system
8 beeps	Display memory read/write error	Video adapter missing or with faulty memory
OH LED On	System OH	System Overheat

Notes

Appendix B

Software Installation Instructions

B-1 Installing Drivers

Drivers and utility software for this motherboard may be downloaded at the Supermicro website at <http://www.supermicro.com>. To install these software programs and drivers, run the downloaded software and follow these instructions.

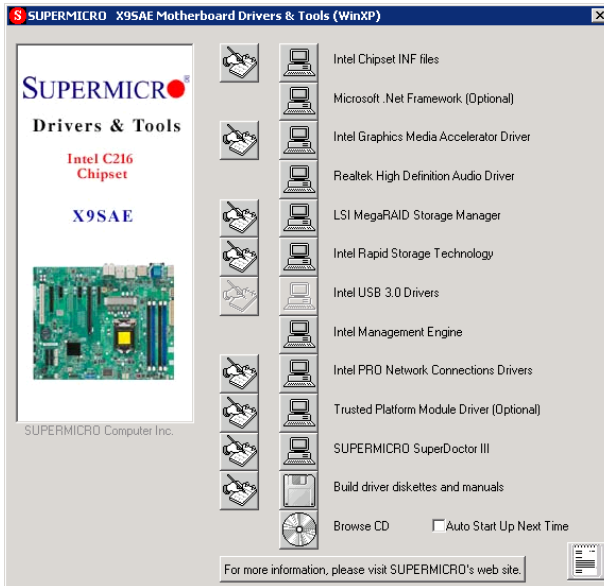

Driver/Tool Installation Display Screen



Note 1. Click the icons showing a hand writing on the paper to view the readme files for each item. Click on a computer icon to the right of an item to install this item (from top to the bottom), one at a time. After installing each item, you must reboot the system before proceeding with the next item on the list. The bottom icon with a CD on it allows you to view the entire contents of the CD.

Note 2. When making a storage driver diskette by booting into a Driver CD, please set the SATA Configuration to "Compatible Mode" and configure SATA as IDE in the BIOS Setup. After making the driver diskette, be sure to change the SATA settings back to your original settings.

B-2 Configuring SuperDoctor[®] III

The SuperDoctor III program is a Web-based management tool that supports remote management capability. It includes Remote and Local Management tools. The local management tool is called the SD III Client. The SuperDoctor III program included on the CDROM that came with your motherboard allows you to monitor the environment and operations of your system. SuperDoctor III displays crucial system information such as CPU temperature, system voltages and fan status. See the Figure below for a display of the SuperDoctor III interface.

Note: 1 The default user name and password are ADMIN.



Note 2: In the Windows OS environment, the SuperDoctor III settings take precedence over the BIOS settings. When first installed, SuperDoctor III adopts the temperature threshold settings previously set in BIOS. Any subsequent changes to these thresholds must be made within SuperDoctor, since the settings override the BIOS settings. For the Windows OS to adopt the BIOS temperature threshold settings, please change the SD III Client settings to be the same as those set in BIOS.

SuperDoctor III Interface Display Screen-I (Health Information)

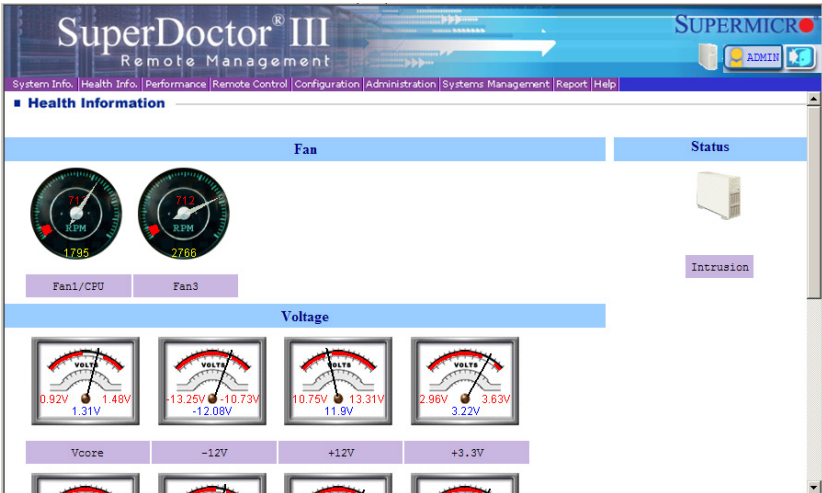

SuperDoctor III Interface Display Screen-II (Remote Control)



Graceful power control (cancelable)

Super Doctor III allows a user to inform the OS to reboot or shut down the system within 30 seconds. On the system console, a pop-up window will appear with a message telling the local user to save his working files. Before the system reboots or shuts down, it's allowed to cancel the action either locally or remotely.

Power control (noncancelable)

Super Doctor III allows a user to inform the OS to reboot or shut down the system right away. The system will reboot or shut down without any warning messages. It's not allowed to cancel the action.



Note: The SuperDoctor III software and manual may be downloaded from our Website at:

<http://www.supermicro.com/products/accessories/software/SuperDoctorIII.cfm>.

For Linux, we still recommend that you use SuperDoctor II, this version is also available for download at the link above.

Notes

Appendix C

UEFI BIOS Recovery Instructions



Warning! Do not upgrade the BIOS unless your system has a BIOS-related issue. Flashing the wrong BIOS can cause irreparable damage to the system. In no event shall Supermicro be liable for direct, indirect, special, incidental, or consequential damages arising from a BIOS update. If you need to update the BIOS, do not shut down or reset the system while the BIOS is updating to avoid possible boot failure.

C-1 An Overview to the UEFI BIOS

The Unified Extensible Firmware Interface (UEFI) specification provides a software-based interface between the operating system and the platform firmware in the pre-boot environment. The UEFI specification supports an architecture-independent mechanism for add-on card initialization to allow the UEFI OS loader, which is stored in the add-on card, to boot up the system. UEFI offers a clean, hand-off control to a computer system at bootup.

C-2 How to Recover the UEFI BIOS Image (-the Main BIOS Block)

An AMIBIOS flash chip consists of a boot sector block and a main BIOS code block (a main BIOS image). The boot sector block contains critical BIOS codes, including memory detection and recovery codes for the user to flash a new BIOS image if the original BIOS image is corrupted. When the system power is on, the boot sector codes execute first. Once it is completed, the main BIOS code will continue with system initialization and bootup.



Note: Follow the BIOS Recovery instructions below for BIOS recovery when the main BIOS block crashes. However, when the BIOS Boot sector crashes, you will need to send the motherboard back to Supermicro for RMA repair.

C-3 To Recover the Boot Sector Using a USB-Attached Device

This feature allows the user to recover a BIOS image using a USB-attached device without additional utilities used. A USB flash device such as a USB Flash Drive, or

a USB CD/DVD ROM/RW device can be used for this purpose. However, a USB Hard Disk drive cannot be used for BIOS recovery at this time.

To perform UEFI BIOS recovery using a USB-attached device, follow the instructions below.

1. Using a different machine, copy the "Super.ROM" binary image file into the disc Root "\\" Directory of a USB device or a writeable CD/DVD.



Note: If you cannot locate the "Super.ROM" file in your driver disk, visit our website at www.supermicro.com to download the BIOS image into a USB flash device and rename it to "Super ROM" for BIOS recovery use.

2. Insert the USB device that contains the new BIOS image ("Super.ROM") into your USB drive and power on the system
3. While powering on the system, keep pressing <Ctrl> and <Home> simultaneously on your PS2 keyboard until your hear two short beeps. This may take from a few seconds to one minute.
4. After locating the new BIOS binary image, the system will enter the BIOS Recovery menu as shown below.

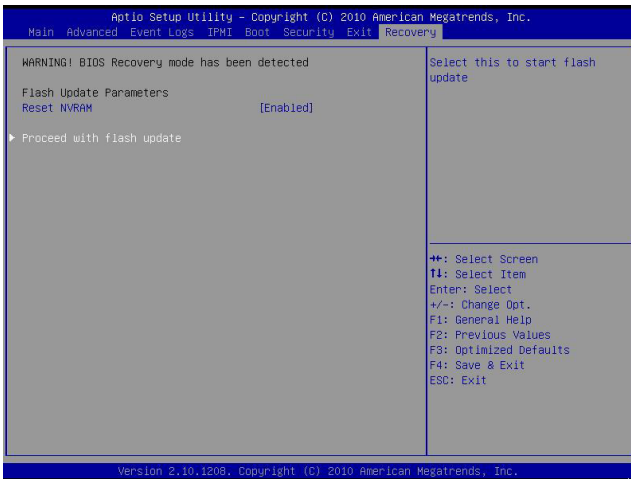

Note: At this point, you may decide if you want to start with BIOS Recovery. If you decide to proceed with BIOS Recovery, follow the procedures below.

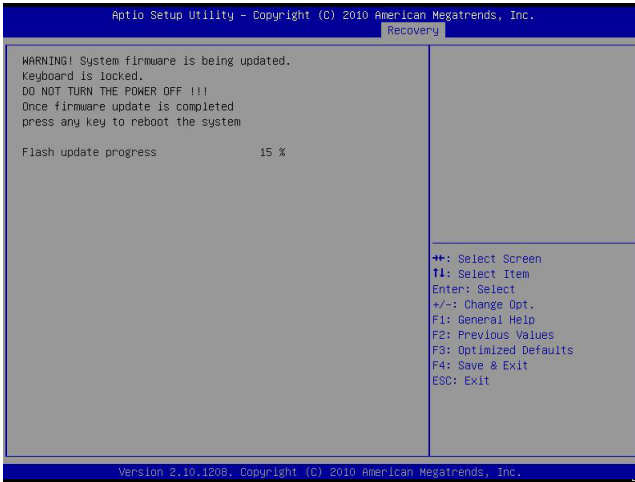

- When the screen as shown above displays, using the arrow key, select the item- "Proceed with flash update" and press the <Enter> key. You will see the progress of BIOS Recovery as shown in the screen below.

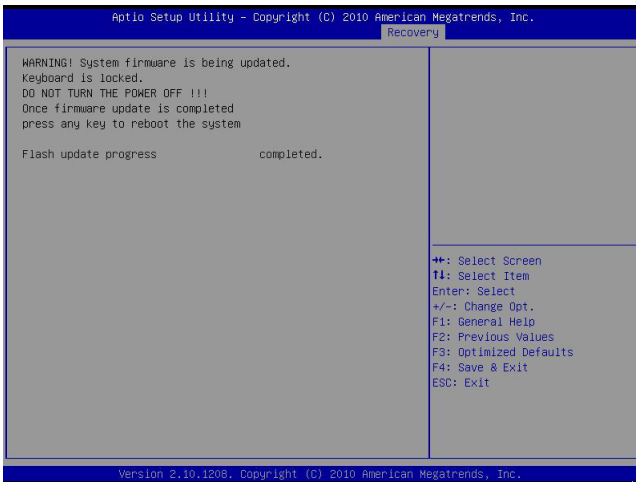

Note: Do not interrupt the process of BIOS flashing until it is completed.

- After the process of BIOS Recovery is complete, press any key to reboot the system.
- Using a different system, extract the BIOS package into a bootable USB flash drive.

8. When a DOS prompt appears, enter AMI.BAT BIOSname.### at the prompt.



Note: Do not interrupt this process until BIOS flashing is completed.

9. After seeing the message that BIOS update is completed, unplug the AC power cable from the power supply to clear CMOS, and then plug the AC power cable in the power supply again to power on the system.
10. Press continuously to enter the BIOS Setup utility.
11. Press <F3> to load default settings.
12. After loading default settings, press <F4> to save the settings and exit the BIOS Setup utility.

(Disclaimer Continued)

The products sold by Supermicro are not intended for and will not be used in life support systems, medical equipment, nuclear facilities or systems, aircraft, aircraft devices, aircraft/emergency communication devices or other critical systems whose failure to perform be reasonably expected to result in significant injury or loss of life or catastrophic property damage. Accordingly, Supermicro disclaims any and all liability, and should buyer use or sell such products for use in such ultra-hazardous applications, it does so entirely at its own risk. Furthermore, buyer agrees to fully indemnify, defend and hold Supermicro harmless for and against any and all claims, demands, actions, litigation, and proceedings of any kind arising out of or related to such ultra-hazardous use or sale.