

# DG17

sub-miniature pcb automotive relay

# DURAKOOL



- 15A continuous current capacity
- AgSnOInO contacts for motor & lamp loads
- open, dust cover and sealed versions
- Automotive oriented design

RoHS Compliant

## Contacts

Contact number & arrangement	SPST-NO (1 Form A); SPDT (1 Form C); SPST-NO-DM (1 Form U); SPDT-DB-DM (1 Form W)						
Contact material	AgNi0.15; AgNi90/10; AgSnOInO; AgCdO						
Max. switching voltage	DC	Current dependent - see Fig 3					
Min. switching current / voltage	0.1A/5VDC (AgNi0.15), 0.5A/5VDC (AgSnOInO)						
		1 Form A	1 Form C		1 Form U	1 Form W	
			NO	NC		NO	NC
Max. continuous current	DC1	15A	15A	10A	2 x 10A	2 x 7A	2 x 5A
Max. switching current	Make	60A (100A AgSnOInO)	60A (100A AgSnOInO)	12A	2 x 40A (70A AgSnOInO)	2 x 30A (50A AgSnOInO)	2 x 5A
	Break	20A	20A	10A	2 x 20A	2 x 15A	2 x 5A
Initial resistance	100mΩ, max. at 0.1A/6VDC						
<b>Coil</b>							
Rated voltage	DC	6, 12, 24V					
Must release voltage	See coil table 1						
Operating range of supply voltage	See coil table 1						
Rated power consumption	DC	1.1W approx.					
<b>Insulation</b>							
Insulation resistance	100MΩ at 500VDC, 50%RH						
Dielectric strength	coil to contact	500Vrms, 1 min.					
<b>General Data</b>							
Operating time (typical)	mS	3					
Release time (typical)	mS	1.5					
Electrical Life	ops	2 x 10 <sup>5</sup> (see Note 2)					
Mechanical life	ops	1 x 10 <sup>7</sup>					
Dimensions	L x W x H	17.7 x 15.2 x 19.7 (covered - excluding terminals)					
Weight	open: 8g / covered: 12g approx.						
Ambient temperature	storage	-40 to 155°C					
	operating	-40 to 85°C (higher to special order)					
Shock resistance	Functional: 10g 11mS; Destructive: 100g						
Vibration resistance	Functional: NO 20g; NC 10g 10-200Hz						
Drop resistance	1M height drop on concrete in final enclosure						

# DURAKOOL



# DG17

sub-miniature pcb automotive relay



Overall Dimensions

Fig. 1

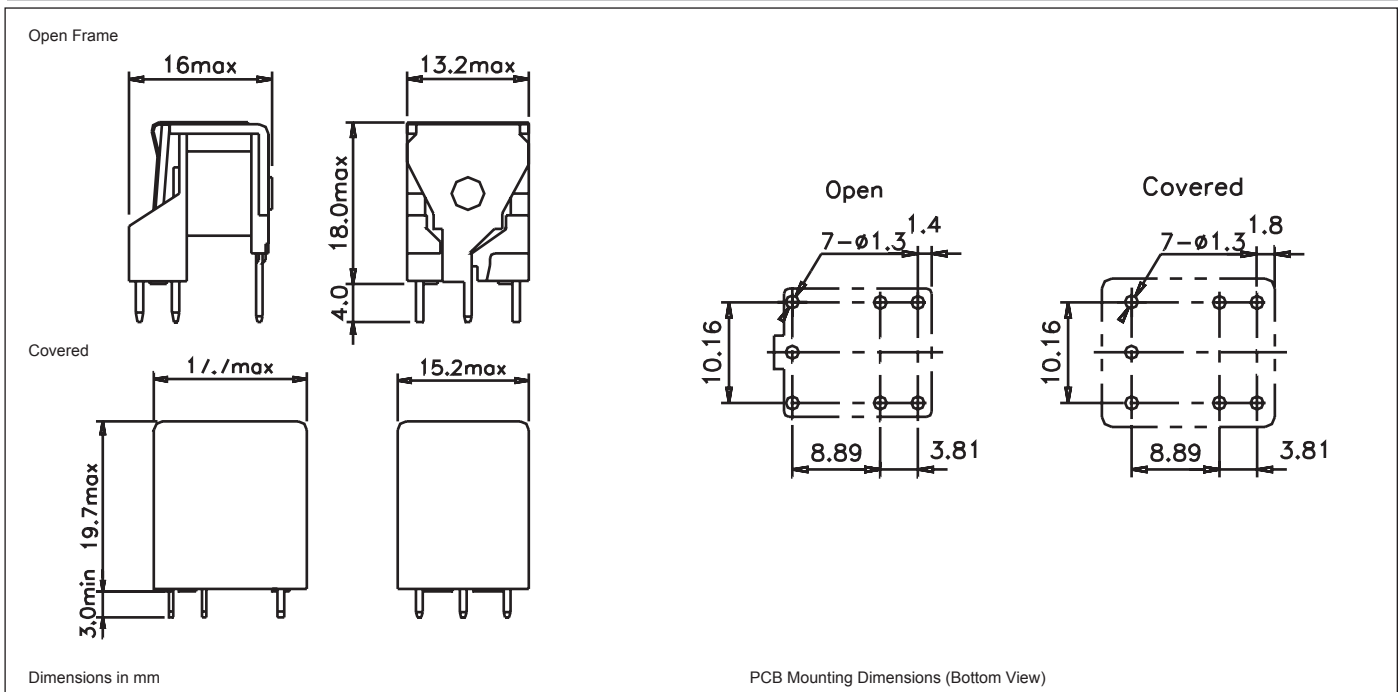

Wiring Diagrams

Fig. 2

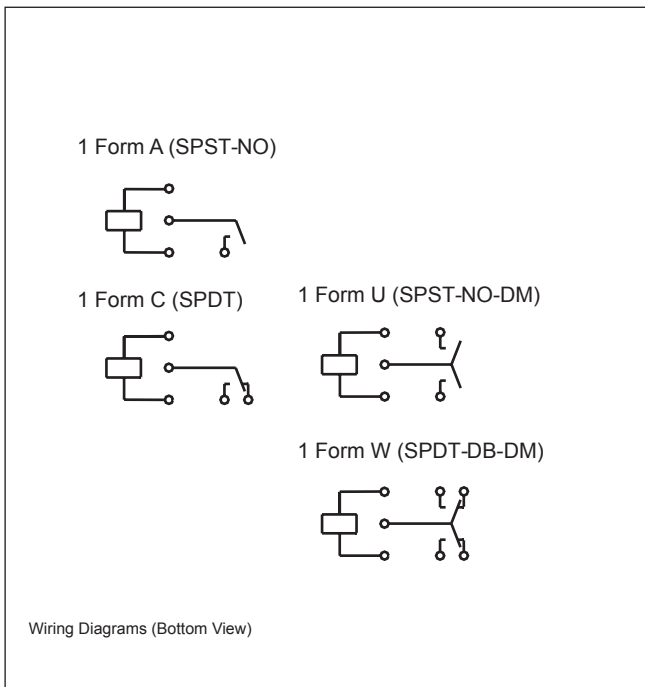

Reference Curves

Fig. 3

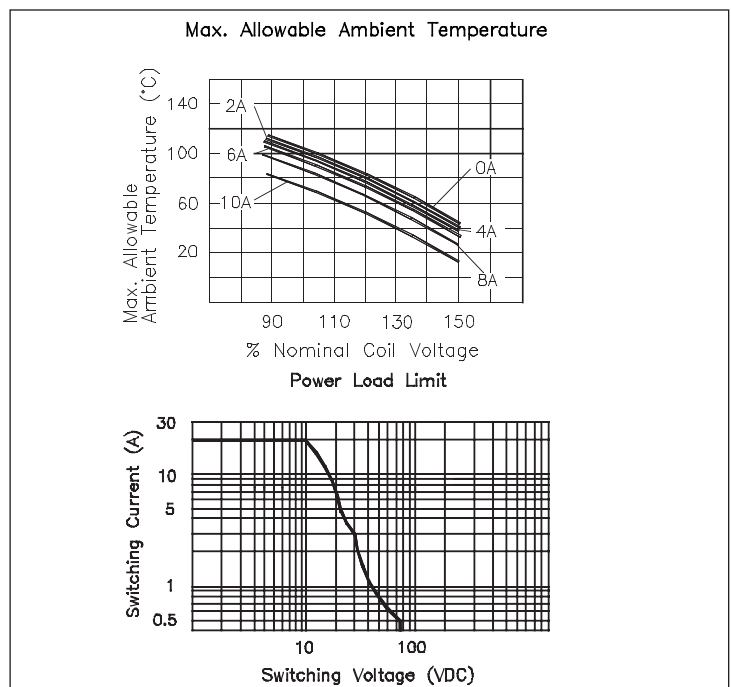

Notes:

- 1: All parameters, unless otherwise specified, are measured at ambient temperature of 23 $^{\circ}$ C.
- 2: Electrical life obtained at resistive or inductive load at 10A, 15VDC for 1 Form A/C/U/ and 7A, 15VDC for 1 Form W, with suitable arc suppression circuit attached and with operating frequency of 1 op/sec.
- 3: Maximum make current refers to lamp load inrush current.
- 4: For optimum electrical life, please remove the knock off nib of the sealed version after cleaning process.

Specifications are subject to change without notice. E&OE.

American Electronic Components Inc., 1101 Lafayette St. Elkhart, IN46516

