

High-side driver with CurrentSense analog feedback for automotive applications

Datasheet - production data



Features

Max transient supply voltage	V _{CC}	40 V
Operating voltage range	V _{CC}	4 to 28 V
Typ. on-state resistance (per Ch)	R _{ON}	7 mΩ
Current limitation (typ)	I _{LIMH}	100 A
Stand-by current (max)	I _{STBY}	0.5 μA

- Automotive qualified
- General
 - Single channel smart high-side driver with CurrentSense analog feedback
 - Very low standby current
 - Compatible with 3 V and 5 V CMOS outputs
- Diagnostic functions
 - Overload and short to ground (power limitation) indication
 - Thermal shutdown indication
 - OFF-state open-load detection
 - Output short to V_{CC} detection
 - Sense enable/ disable
- Protections
 - Undervoltage shutdown
 - Overvoltage clamp
 - Load current limitation

- Self limiting of fast thermal transients
- Loss of ground and loss of V_{CC}
- Configurable latch-off on overtemperature or power limitation
- Reverse battery
- Electrostatic discharge protection

Applications

- All types of Automotive resistive, inductive and capacitive loads
- Specially intended for Automotive Headlamps

Description

The device is a single channel high-side driver manufactured using ST proprietary VIPower® technology and housed in the Octapak package. The device is designed to drive 12 V automotive grounded loads through a 3 V and 5 V CMOS-compatible interface, and to provide protection and diagnostics.

The device integrates advanced protective functions such as load current limitation, overload active management by power limitation and overtemperature shutdown.

A combination of INPUT and FR_DIAG pins latches the output in case of fault, disables the latch-off functionality and enables OFF-state diagnostic.

Table 1: Device summary

Package	Order codes
	Tape and reel
Octapak	VN7007ALHTR

Contents

1	Block diagram and pin description	5
2	Electrical specification.....	7
2.1	Absolute maximum ratings	7
2.2	Thermal data	8
2.3	Main electrical characteristics	8
2.4	Electrical characteristics curves	15
3	Protections.....	19
3.1	Power limitation.....	19
3.2	Thermal shutdown.....	19
3.3	Current limitation	19
3.4	Negative voltage clamp.....	19
4	Application information	20
4.1	GND protection network against reverse battery.....	20
4.2	Immunity against transient electrical disturbances.....	21
4.3	MCU I/Os protection.....	21
4.4	CS - analog current sense	22
4.4.1	Principle of CurrentSense signal generation	23
4.4.2	Short to VCC and OFF-state open-load detection	25
5	Maximum demagnetization energy (VCC = 16 V)	27
6	Package and PCB thermal data.....	28
6.1	Octapak thermal data.....	28
7	Package information	31
7.1	Octapak package information.....	31
7.2	Octapak packing information.....	33
7.3	Octapak marking information	35
8	Revision history	36

List of tables

Table 1: Device summary	1
Table 2: Pin functions	5
Table 3: Suggested connections for unused and not connected pins.....	6
Table 4: Absolute maximum ratings	7
Table 5: Thermal data	8
Table 6: Power section	8
Table 7: Switching.....	9
Table 8: Logic Inputs.....	10
Table 9: Protections	10
Table 10: Current Sense.....	11
Table 11: Truth table	14
Table 12: FR_DIAG functionality	14
Table 13: ISO 7637-2 - electrical transient conduction along supply line.....	21
Table 14: CurrentSense pin levels in off-state.....	25
Table 15: PCB properties	28
Table 16: Octapak mechanical data	32
Table 17: Reel dimensions	33
Table 18: Document revision history	36

List of figures

Figure 1: Block diagram.....	5
Figure 2: Configuration diagram (top view).....	6
Figure 3: Current and voltage conventions.....	7
Figure 4: Switching times and Pulse skew	13
Figure 5: TDSTKON.....	13
Figure 6: OFF-state output current	15
Figure 7: Standby current	15
Figure 8: IGND(ON) vs. Tcase	15
Figure 9: Logic Input high level voltage	15
Figure 10: Logic Input low level voltage.....	15
Figure 11: High level logic input current	15
Figure 12: Low level logic input current	16
Figure 13: Logic Input hysteresis voltage	16
Figure 14: Undervoltage shutdown.....	16
Figure 15: On-state resistance vs. Tcase	16
Figure 16: On-state resistance vs. VCC	16
Figure 17: Turn-on voltage slope.....	16
Figure 18: Turn-off voltage slope.....	17
Figure 19: Won vs Tcase.....	17
Figure 20: Woff vs Tcase.....	17
Figure 21: ILIMH vs. Tcase.....	17
Figure 22: Turn-off output voltage clamp.....	17
Figure 23: OFF-state open-load voltage detection threshold	17
Figure 24: Vsense clamp vs Tcase.....	18
Figure 25: Vsenseh vs Tcase	18
Figure 26: Application diagram	20
Figure 27: Simplified internal structure	20
Figure 28: CurrentSense and diagnostic – block diagram.....	22
Figure 29: CurrentSense block diagram	23
Figure 30: Analogue HSD – open-load detection in off-state	24
Figure 31: Open-load / short to VCC condition.....	25
Figure 32: Maximum turn off current versus inductance	27
Figure 33: Octapak on two-layers PCB (2s0p to JEDEC JESD 51-5).....	28
Figure 34: Octapak on four-layers PCB (2s2p to JEDEC JESD 51-7)	28
Figure 35: Rthj-amb vs PCB copper area in open box free air conditions	29
Figure 36: Octapak thermal impedance junction ambient single pulse	29
Figure 37: Thermal fitting model for Octapak	30
Figure 38: Octapak package dimensions	31
Figure 39: Octapack reel 13"	33
Figure 40: Octapak carrier tape	34
Figure 41: Octapak schematic drawing of leader and trailer tape	34
Figure 42: Octapak marking information.....	35

1 Block diagram and pin description

Figure 1: Block diagram

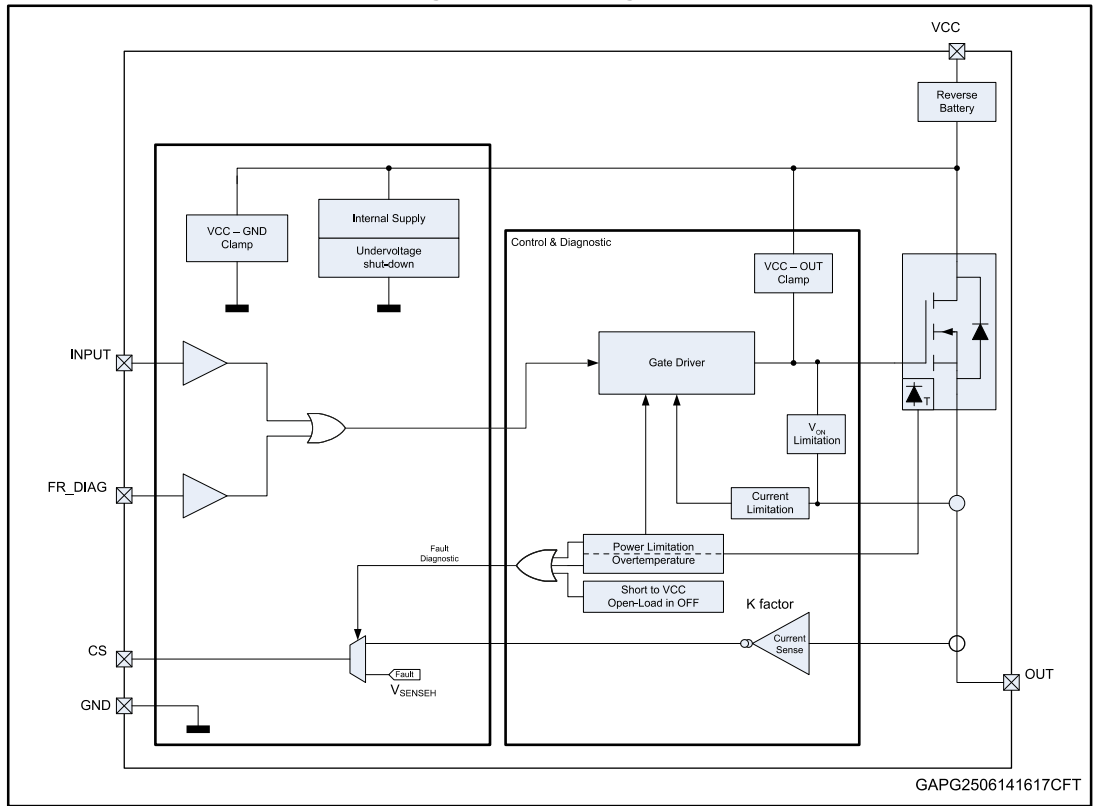

Table 2: Pin functions

Name	Function
V _{CC}	Battery connection.
OUTPUT	Power outputs. All the pins must be connected together.
GND	Ground connection.
INPUT	Voltage controlled input pin with hysteresis. Compatible with 3 V and 5 V CMOS outputs. It controls output switch state.
CS	Analog current sense output pin delivers a current proportional to the load current.
FR_DIAG	It sets auto-restart and latch-off protection. Moreover, it enables OFF-state diagnostic (see Table 12: "FR_DIAG functionality").

Figure 2: Configuration diagram (top view)

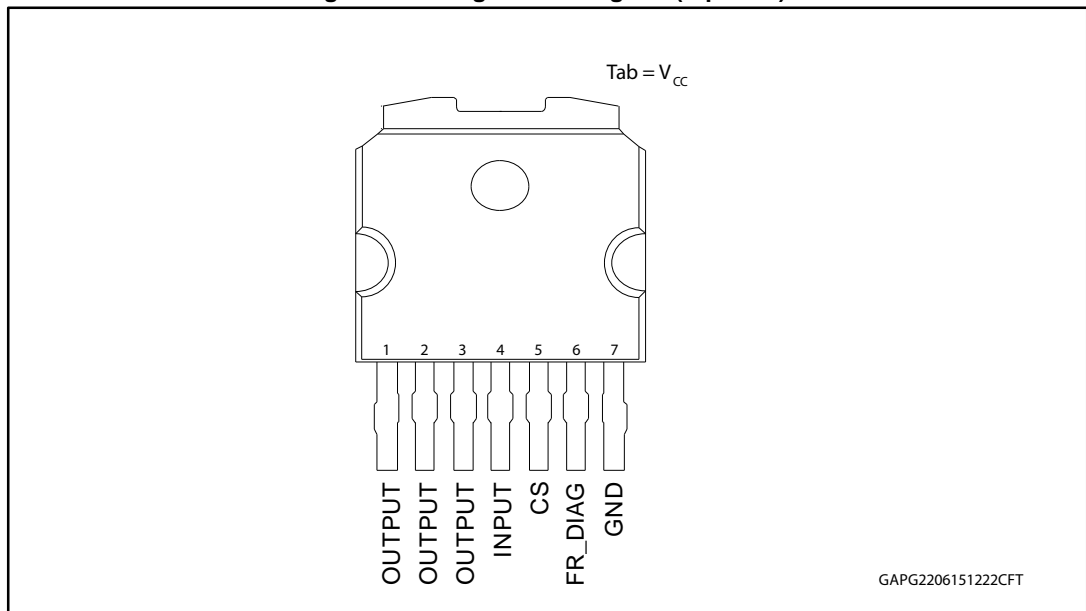

Table 3: Suggested connections for unused and not connected pins

Connection / pin	CS	N.C.	Output	Input	FR_DIAG
Floating	Not allowed	X ⁽¹⁾	X	X	X
To ground	Through 1 kΩ resistor	X	Not allowed	Through 15 kΩ resistor	Through 15 kΩ resistor

Notes:

⁽¹⁾X: do not care.

2 Electrical specification

Figure 3: Current and voltage conventions

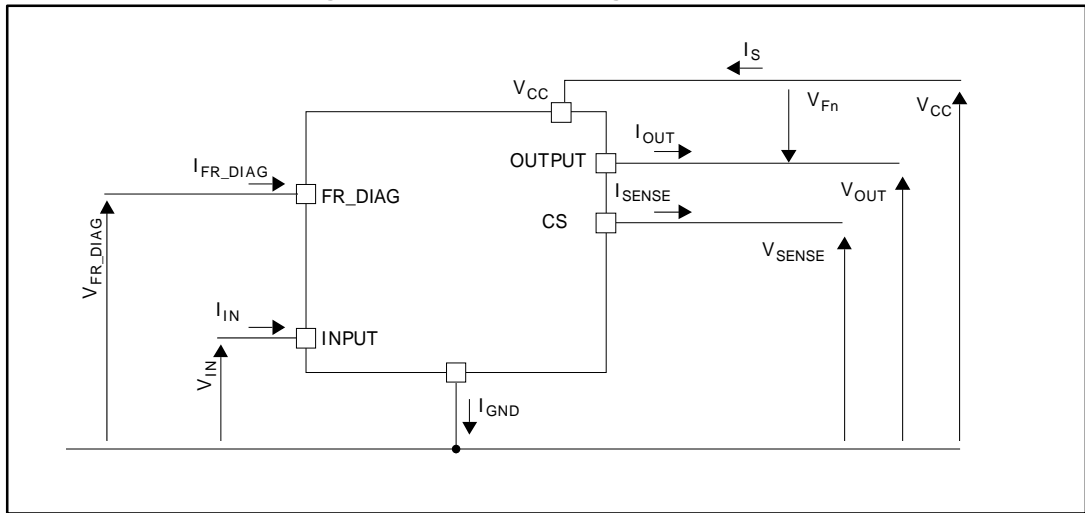

$V_F = V_{OUT} - V_{CC}$ when $V_{OUT} > V_{CC}$ and INPUT = LOW

2.1 Absolute maximum ratings

Stressing the device above the rating listed in [Table 4: "Absolute maximum ratings"](#) may cause permanent damage to the device. These are stress ratings only and operation of the device at these or any other conditions above those indicated in the operating sections of this specification is not implied. Exposure to the conditions in table below for extended periods may affect device reliability.

Table 4: Absolute maximum ratings

Symbol	Parameter	Value	Unit
V_{CC}	DC supply voltage	38	V
$-V_{CC}$	Reverse DC supply voltage	16	
V_{CCPK}	Maximum transient supply voltage (ISO7637-2:2004 Pulse 5b level IV clamped to 40 V; $R_L = 4 \Omega$)	40	
V_{CCJS}	Maximum jump start voltage for single pulse short circuit protection	28	
$-I_{GND}$	DC reverse ground pin current	200	mA
I_{OUT}	OUTPUT DC output current	Internally limited	A
$-I_{OUT}$	Reverse DC output current	30	
I_{IN}	INPUT DC input current	-1 to 10	mA
I_{FR_DIAG}	FR_DIAG DC input current		
I_{SENSE}	CS pin DC output current ($V_{GND} = V_{CC}$ and $V_{SENSE} < 0$ V)	10	mA
	CS pin DC output current in reverse ($V_{CC} < 0$ V)	-20	

Symbol	Parameter	Value	Unit
E_{MAX}	Maximum switching energy (single pulse) ($T_{DEMAG} = 0.4 \text{ ms}$; $T_{jstart} = 150 \text{ }^\circ\text{C}$)	170	mJ
V_{ESD}	Electrostatic discharge (JEDEC 22A-114F)	4000	V
	• INPUT	2000	V
	• CurrentSense	4000	V
	• FR_DIAG	4000	V
	• OUTPUT	4000	V
V_{ESD}	Charge device model (CDM-AEC-Q100-011)	750	V
T_j	Junction operating temperature	-40 to 150	$^\circ\text{C}$
T_{stg}	Storage temperature	-55 to 150	

2.2 Thermal data

Table 5: Thermal data

Symbol	Parameter	Typ. value	Unit
$R_{thj-board}$	Thermal resistance junction-board (JEDEC JESD 51-8) ⁽¹⁾	2.8	$^\circ\text{C/W}$
$R_{thj-amb}$	Thermal resistance junction-ambient (JEDEC JESD 51-2) ⁽²⁾	58.3	
$R_{thj-amb}$	Thermal resistance junction-ambient (JEDEC JESD 51-2) ⁽¹⁾	15.8	

Notes:

⁽¹⁾Device mounted on four-layers 2s2p PCB

⁽²⁾Device mounted on two-layers 2s0p PCB with 2 cm² heatsink copper trace

2.3 Main electrical characteristics

7 V < V_{CC} < 28 V; -40°C < T_j < 150°C, unless otherwise specified.

All typical values refer to $V_{CC} = 13 \text{ V}$; $T_j = 25^\circ\text{C}$, unless otherwise specified.

Table 6: Power section

Symbol	Parameter	Test conditions	Min.	Typ.	Max.	Unit
V_{CC}	Operating supply voltage		4	13	28	V
V_{USD}	Undervoltage shutdown				4	
$V_{USDReset}$	Undervoltage shutdown reset				5	
$V_{USDhyst}$	Undervoltage shutdown hysteresis			0.3		
R_{ON}	On-state resistance	$I_{OUT} = 6 \text{ A}$; $T_j = 25^\circ\text{C}$		7		mΩ
		$I_{OUT} = 6 \text{ A}$; $T_j = 150^\circ\text{C}$			14.3	
		$I_{OUT} = 6 \text{ A}$; $V_{CC} = 4 \text{ V}$; $T_j = 25^\circ\text{C}$			10.5	
R_{ON_Rev}	R_{DSON} in reverse battery condition	$V_{CC} = -13 \text{ V}$; $I_{OUT} = -6 \text{ A}$; $T_j = 25^\circ\text{C}$		7		mΩ
V_{clamp}	Clamp voltage	$I_S = 20 \text{ mA}$; $T_j = -40^\circ\text{C}$	38			V
		$I_S = 20 \text{ mA}$; $25^\circ\text{C} < T_j < 150^\circ\text{C}$	41	46	52	V

Symbol	Parameter	Test conditions	Min.	Typ.	Max.	Unit
I _{STBY}	Supply current in standby at V _{CC} = 13 V ⁽¹⁾	V _{CC} = 13 V; V _{IN} = V _{OUT} = V _{FR_DIAG} = 0 V; T _j = 25°C			0.5	μA
		V _{CC} = 13 V; V _{IN} = V _{OUT} = V _{FR_DIAG} = 0 V; T _j = 85°C ⁽²⁾			0.5	
		V _{CC} = 13 V; V _{IN} = V _{OUT} = V _{FR_DIAG} = 0 V; T _j = 125°C			3	
t _{D_STBY}	Standby mode blanking time	V _{CC} = 13 V; V _{IN} = 5 V; V _{FR_DIAG} = 0 V; I _{OUT} = 0 A	60	300	550	μs
I _{S(ON)}	Supply current	V _{CC} = 13 V; V _{FR_DIAG} = 0 V; V _{IN} = 5 V; I _{OUT} = 0 A		3	6.5	mA
I _{GND(ON)}	Control stage current consumption in ON state. All channels active.	V _{CC} = 13 V; V _{FR_DIAG} = 5 V; V _{IN} = 5 V; I _{OUT} = 6 A			9	mA
I _{L(off)}	Off-state output current at V _{CC} = 13 V	V _{IN} = V _{OUT} = 0 V; V _{CC} = 13 V; T _j = 25°C	0	0.01	0.5	μA
		V _{IN} = V _{OUT} = 0 V; V _{CC} = 13 V; T _j = 125°C	0		3	
V _F	Output - V _{CC} diode voltage	I _{OUT} = -6 A; T _j = 150°C			0.7	V

Notes:

⁽¹⁾PowerMOS leakage included.

⁽²⁾Parameter specified by design; not subject to production test.

Table 7: Switching

V _{CC} = 13 V; -40°C < T _j < 150°C, unless otherwise specified						
Symbol	Parameter	Test conditions	Min.	Typ.	Max.	Unit
t _{d(on)} ⁽¹⁾	Turn-on delay time at T _j = 25 °C	R _L = 2.2 Ω	10	65	120	μs
t _{d(off)} ⁽¹⁾	Turn-off delay time at T _j = 25 °C		10	55	100	
(dV _{OUT} /dt) _{on} ⁽¹⁾	Turn-on voltage slope at T _j = 25 °C	R _L = 2.2 Ω	0.1	0.36	0.8	V/μs
(dV _{OUT} /dt) _{off} ⁽¹⁾	Turn-off voltage slope at T _j = 25 °C		0.1	0.47	0.8	
W _{ON}	Switching energy losses at turn-on (t _{won})	R _L = 2.2 Ω	—	0.6	1.7 ⁽²⁾	mJ
W _{OFF}	Switching energy losses at turn-off (t _{woff})	R _L = 2.2 Ω	—	0.6	1.7 ⁽²⁾	mJ
t _{SKEW} ⁽¹⁾	Differential Pulse skew (t _{PHL} - t _{PLH})	R _L = 2.2 Ω	-65	-15	35	μs

Notes:

⁽¹⁾See [Figure 4: "Switching times and Pulse skew"](#).

⁽²⁾Parameter guaranteed by design and characterization; not subject to production test.

Table 8: Logic Inputs

7 V < V _{CC} < 28 V; -40°C < T _j < 150°C						
Symbol	Parameter	Test conditions	Min.	Typ.	Max.	Unit
INPUT characteristics						
V _{IL}	Input low level voltage				0.9	V
I _{IL}	Low level input current	V _{IN} = 0.9 V	1			μA
V _{IH}	Input high level voltage		2.1			V
I _{IH}	High level input current	V _{IN} = 2.1 V			10	μA
V _{I(hyst)}	Input hysteresis voltage		0.2			V
V _{ICL}	Input clamp voltage	I _{IN} = 1 mA	5.3		7.5	V
		I _{IN} = -1 mA		-0.7		
FR_DIAG characteristics (7 V < V_{CC} < 18 V)						
V _{FR_DIAGL}	Input low level voltage				0.9	V
I _{FR_DIAGL}	Low level input current	V _{IN} = 0.9 V	1			μA
V _{FR_DIAGH}	Input high level voltage		2.1			V
I _{FR_DIAGH}	High level input current	V _{IN} = 2.1 V			10	μA
V _{FR_DIAG(hyst)}	Input hysteresis voltage		0.2			V
V _{FR_DIAGCL}	Input clamp voltage	I _{IN} = 1 mA	5.3		7.5	V
		I _{IN} = -1 mA		-0.7		

Table 9: Protections

7 V < V _{CC} < 18 V; -40°C < T _j < 150°C						
Symbol	Parameter	Test conditions	Min.	Typ.	Max.	Unit
I _{LIMH} ⁽¹⁾	DC short circuit current	V _{CC} = 13 V	70	100	140	A
		4 V < V _{CC} < 18 V ⁽²⁾			140	
I _{LIML}	Short circuit current during thermal cycling	V _{CC} = 13 V; T _R < T _j < T _{TSD}		33		A
T _{TSD}	Shutdown temperature		150	175	200	°C
T _R	Reset temperature ⁽²⁾		T _{RS} + 1	T _{RS} + 7		°C
T _{RS}	Thermal reset of fault diagnostic indication	V _{FR_DIAG} = 0 V	135			°C
T _{HYST}	Thermal hysteresis (T _{TSD} - T _R) ⁽²⁾			7		°C
ΔT _{J_SD}	Dynamic temperature	T _j = -40°C; V _{CC} = 13 V		60		K
t _{LATCH_RST}	Fault reset time for output unlatch ⁽²⁾	V _{FR_DIAG} = 5 V to 0 V; V _{IN} = 5 V	3	10	20	μs
V _{DEMAG}	Turn-off output voltage clamp	I _{OUT} = 2 A; L = 6 mH; T _j = -40°C	V _{CC} - 38			V
		I _{OUT} = 2 A; L = 6 mH; T _j = 25°C to 150°C	V _{CC} - 41	V _{CC} - 46	V _{CC} - 52	

7 V < V _{CC} < 18 V; -40°C < T _j < 150°C						
Symbol	Parameter	Test conditions	Min.	Typ.	Max.	Unit
V _{ON}	Output voltage drop limitation	I _{OUT} = 1.2 A		20		mV

Notes:

(1)Parameter guaranteed by an indirect test sequence.

(2)Parameter guaranteed by design and characterization; not subject to production test.

Table 10: Current Sense

7 V < V _{CC} < 18 V; -40°C < T _j < 150°C						
Symbol	Parameter	Test conditions	Min.	Typ.	Max.	Unit
V _{SENSE_CL}	CurrentSense clamp voltage	V _{FR_DIAG} = 0 V; I _{SENSE} = 1 mA	-17		-12	V
		V _{FR_DIAG} = 0 V; I _{SENSE} = -1 mA		7		V
Current Sense characteristics						
K _{OL1}	I _{OUT} /I _{SENSE}	I _{OUT} = 10 mA; V _{SENSE} = 0.5 V; V _{SEn} = 5 V	800			
K _{OL2}	I _{OUT} /I _{SENSE}	I _{OUT} = 0.25 A; V _{SENSE} = 0.5 V; V _{SEn} = 5 V			10400	
K ₀	I _{OUT} /I _{SENSE}	I _{OUT} = 1 A; V _{SENSE} = 4 V; V _{SEn} = 5 V	3390	6600	10180	
dK ₀ /K ₀ ⁽¹⁾⁽²⁾	Current sense ratio drift	I _{OUT} = 1 A; V _{SENSE} = 4 V; V _{SEn} = 5 V	-25		25	%
K ₁	I _{OUT} /I _{SENSE}	I _{OUT} = 4.6 A; V _{SENSE} = 4 V; V _{SEn} = 5 V	4080	6570	9530	
dK ₁ /K ₁ ⁽¹⁾⁽²⁾	Current sense ratio drift	I _{OUT} = 4.6 A; V _{SENSE} = 4 V; V _{SEn} = 5 V	-20		20	%
K ₂	I _{OUT} /I _{SENSE}	I _{OUT} = 9 A; V _{SENSE} = 4 V; V _{SEn} = 5 V	4830	6350	8060	
dK ₂ /K ₂ ⁽¹⁾⁽²⁾	Current sense ratio drift	I _{OUT} = 9 A; V _{SENSE} = 4 V; V _{SEn} = 5 V	-13		13	%
K ₃	I _{OUT} /I _{SENSE}	I _{OUT} = 27 A; V _{SENSE} = 4 V; V _{SEn} = 5 V	5600	6300	7150	
dK ₃ /K ₃ ⁽¹⁾⁽²⁾	Current sense ratio drift	I _{OUT} = 27 A; V _{SENSE} = 4 V; V _{SEn} = 5 V	-8		8	%
I _{SENSE0}	CurrentSense leakage current	CurrentSense disabled: V _{FR_DIAG} = 0 V	0		0.5	μA
		CurrentSense disabled: -1 V < V _{SENSE} < 5 V ⁽¹⁾	-0.5		0.5	μA
		CurrentSense enabled: V _{FR_DIAG} = 5 V; V _{IN} = 5 V; I _{OUT} = 0 A	0		2	μA
V _{OUT_CSD} ⁽¹⁾	Output Voltage for CurrentSense shutdown	V _{FR_DIAG} = 5 V; R _{SENSE} = 2.7 kΩ; V _{IN} = 5 V; I _{OUT} = 3 A		5		V

7 V < V _{CC} < 18 V; -40°C < T _j < 150°C						
Symbol	Parameter	Test conditions	Min.	Typ.	Max.	Unit
V _{SENSE_SAT}	Multisense saturation voltage	V _{CC} = 7 V; R _{SENSE} = 2.7 kΩ; V _{FR_DIAG} = 5 V; V _{IN} = 5 V; I _{OUT} = 27 A; T _j = 150°C	5			V
I _{SENSE_SAT} ⁽¹⁾	CS saturation current	V _{CC} = 7 V; V _{SENSE} = 4 V; V _{IN} = 5 V; V _{FR_DIAG} = 5 V; T _j = 150°C	4			mA
I _{OUT_SAT} ⁽¹⁾	Output saturation current	V _{CC} = 7 V; V _{SENSE} = 4 V; V _{IN} = 5 V; V _{FR_DIAG} = 5 V; T _j = 150°C	45			A
OFF-state diagnostic						
V _{OL}	OFF-state open-load voltage detection threshold	V _{IN} = 0 V; V _{FR_DIAG} = 5 V	2	3	4	V
I _{L(off2)}	OFF-state output sink current	V _{IN} = 0 V; V _{OUT} = V _{OL} ; T _j = -40°C to 125°C	-100		-15	μA
t _{DSTKON}	OFF-state diagnostic delay time from falling edge of INPUT (see Figure 5: "TDSTKON")	V _{IN} = 5 V to 0 V; V _{FR_DIAG} = 5 V; I _{OUT} = 0 A; V _{OUT} = 4 V	100	350	700	μs
t _{D_OL_V}	Settling time for valid OFF-state open load diagnostic indication from rising edge of FR_DIAG	V _{IN} = 0 V; V _{FR} = 0 V; V _{OUT} = 4 V; V _{FR_DIAG} = 0 V to 5 V			60	μs
t _{D_VOL}	OFF-state diagnostic delay time from rising edge of V _{OUT}	V _{IN} = 0 V; V _{FR_DIAG} = 5 V; V _{OUT} = 0 V to 4 V		5	30	μs
Fault diagnostic feedback (see Table 11: "Truth table")						
V _{SENSEH}	CurrentSense output voltage in fault condition	V _{CC} = 13 V; V _{IN} = 0 V; V _{FR_DIAG} = 5 V; I _{OUT} = 0 A; V _{OUT} = 4 V; R _{SENSE} = 1 kΩ	5		6.6	V
I _{SENSEH}	CurrentSense output current in fault condition	V _{CC} = 13 V; V _{SENSE} = 5 V	7	20	30	mA
CurrentSense timings (current sense mode)						
t _{DSENSE2H}	Current sense settling time from rising edge of INPUT	V _{IN} = 0 V to 5 V; V _{FR_DIAG} = 5 V; R _{SENSE} = 1 kΩ; R _L = 2.2 Ω		100	300	μs
Dt _{DSENSE2H}	Current sense settling time from rising edge of I _{OUT} (dynamic response to a step change of I _{OUT})	V _{IN} = 5 V; V _{FR_DIAG} = 5 V; R _{SENSE} = 1 kΩ; I _{SENSE} = 90 % of I _{SENSEMAX} ; R _L = 2.2 Ω			200	μs
t _{DSENSE2L}	Current sense turn-off delay time from falling edge of INPUT	V _{IN} = 5 V to 0 V; V _{FR_DIAG} = 5 V; R _{SENSE} = 1 kΩ; R _L = 2.2 Ω		50	250	μs

Notes:

⁽¹⁾Parameter guaranteed by design and characterization; not subject to production test.

⁽²⁾All values refer to V_{CC} = 13 V; T_j = 25°C, unless otherwise specified.

Figure 4: Switching times and Pulse skew

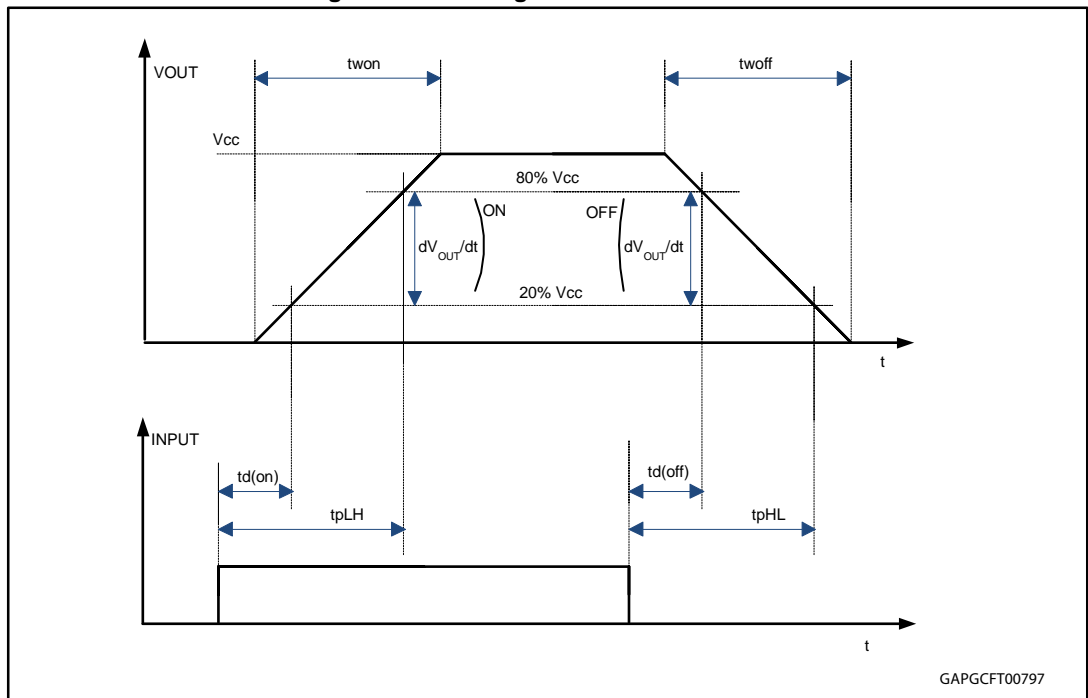

Figure 5: TDSTKON

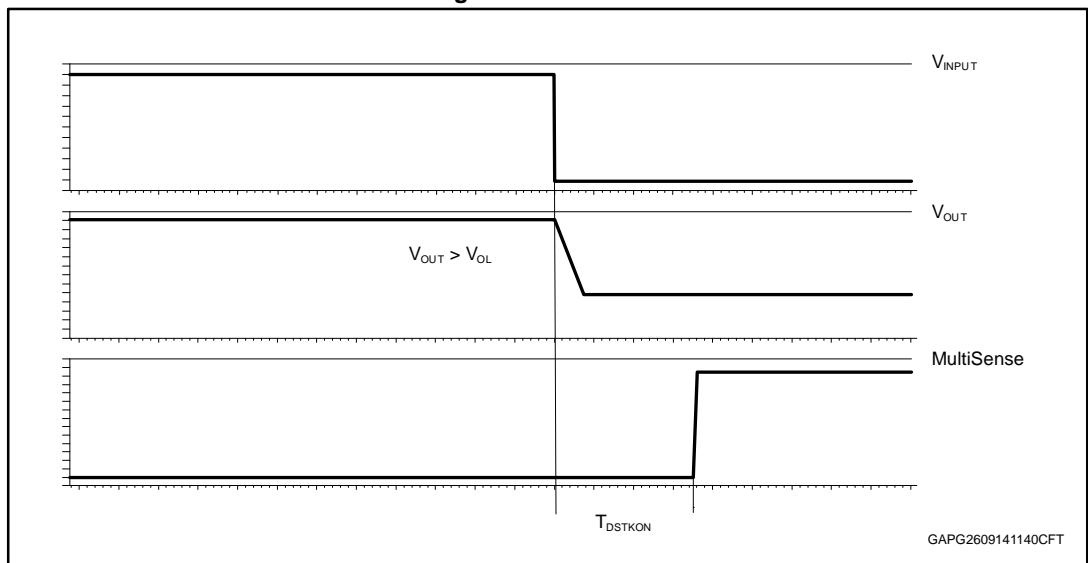

Table 11: Truth table

Mode	Conditions	IN	FR_DIAG	OUT	CurrentSense	Comments
Standby	All logic inputs low	L	L	L	Hi-Z	Low quiescent current consumption
Normal	Nominal load connected; $T_j < 150^\circ\text{C}$	L	H	L	0	OFF-state diagnostic enabled
		H	L	H	$I_{\text{SENSE}} = 1/K * I_{\text{OUT}}$	Autorestart mode
		H	H	H	$I_{\text{SENSE}} = 1/K * I_{\text{OUT}}$	Latch-off mode
Overload	Overload or short to GND causing: $T_j > T_{\text{TSD}}$ or $\Delta T_j > \Delta T_{j_SD}$	H	L	H	V_{SENSEH}	Autorestart mode
		H	H	H	V_{SENSEH}	Latch-off mode
Under-voltage	$V_{\text{CC}} < V_{\text{USD}}$ (falling)	X	X	L	Hi-Z	Re-start when $V_{\text{CC}} > V_{\text{USD}} + V_{\text{USDhyst}}$ (rising)
OFF-state diagnostics	Short to V_{CC}	L	H	H	V_{SENSEH}	
	Open-load	L	H	H		External pull-up
Negative output voltage	Inductive loads turn-off	L	X	$< 0\text{ V}$	0	

Table 12: FR_DIAG functionality

FR_DIAG	Input	Diagnostic	Overload protection
0	0	Disabled	X ⁽¹⁾
0	1	Enabled	Auto-restart
1	0	Enabled (OFF-state diagnostic)	X ⁽¹⁾
1	1	Enabled	Latch-off

Notes:⁽¹⁾X: do not care.

2.4 Electrical characteristics curves

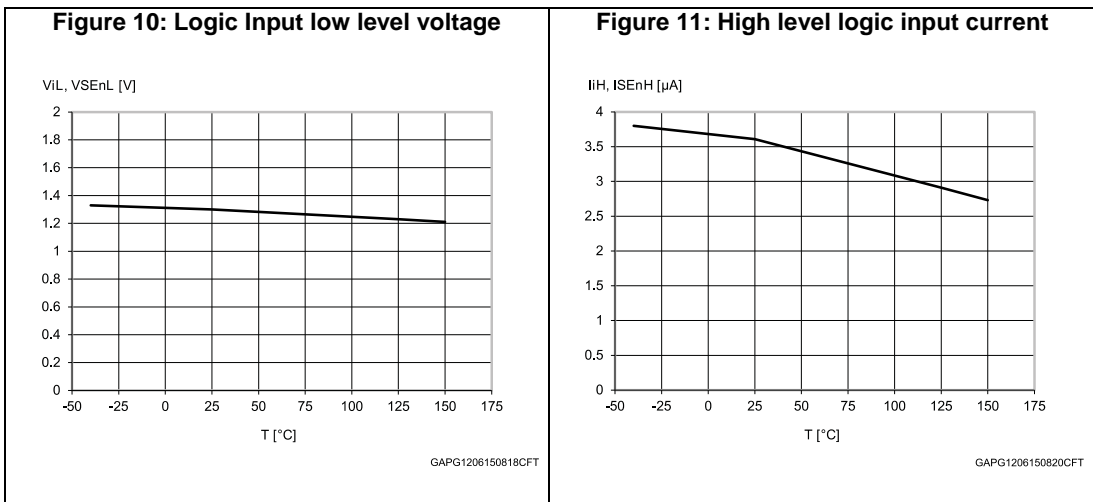
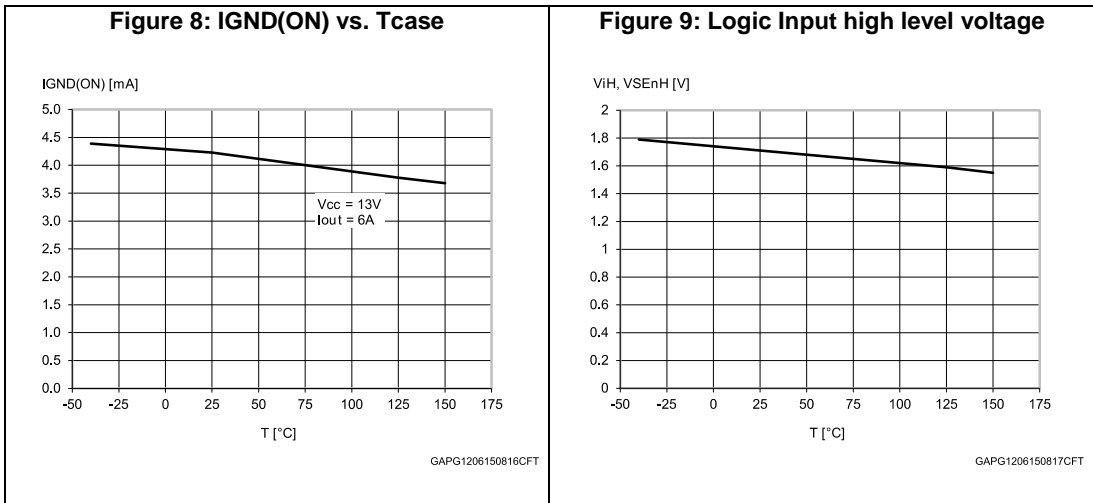
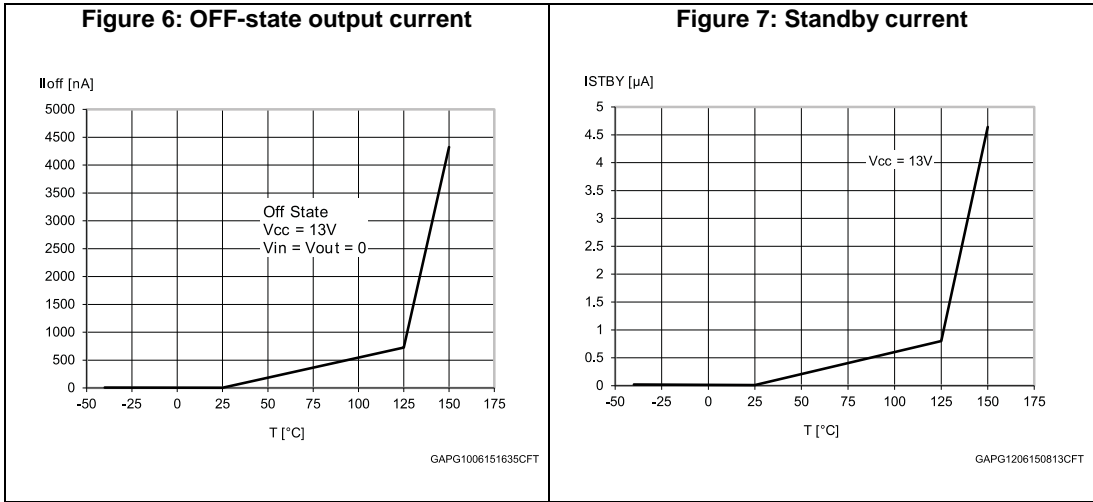
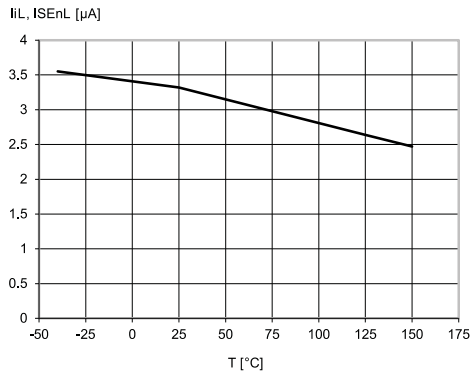
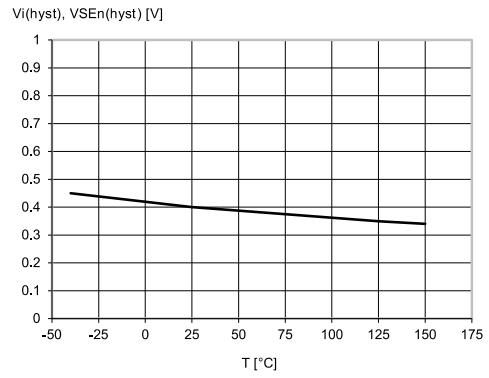

Figure 12: Low level logic input current



GAPG1206150821CFT

Figure 13: Logic Input hysteresis voltage



GAPG1206150824CFT

Figure 14: Undervoltage shutdown

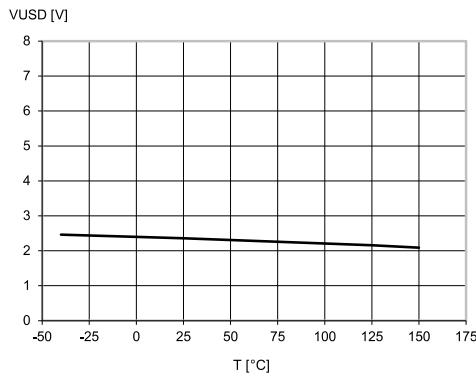

GAPG1206150825CFT

Figure 15: On-state resistance vs. Tcase

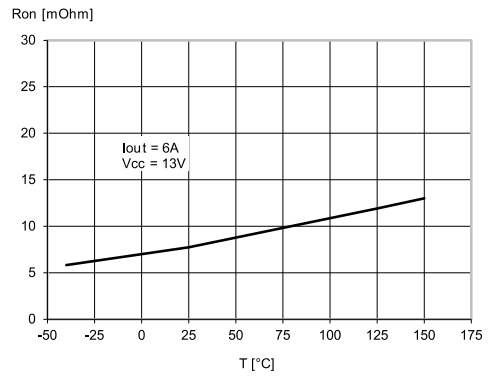

GAPG1206150826CFT

Figure 16: On-state resistance vs. VCC

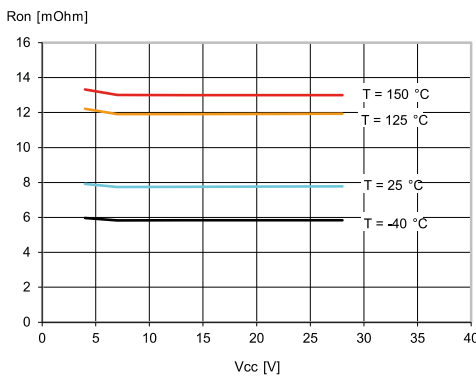

GAPG1206150828CFT

Figure 17: Turn-on voltage slope

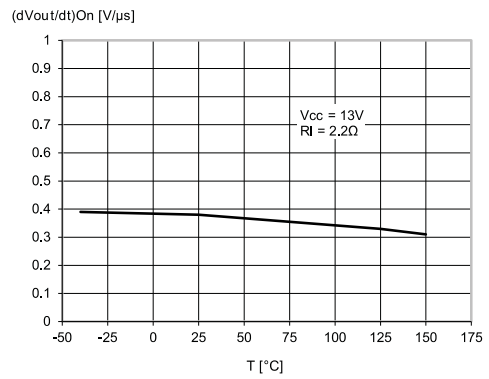

GAPG1206150831CFT

Figure 18: Turn-off voltage slope

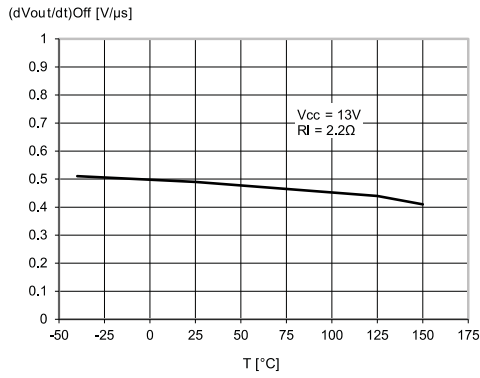

GAPG1206150832CFT

Figure 19: Won vs Tcase

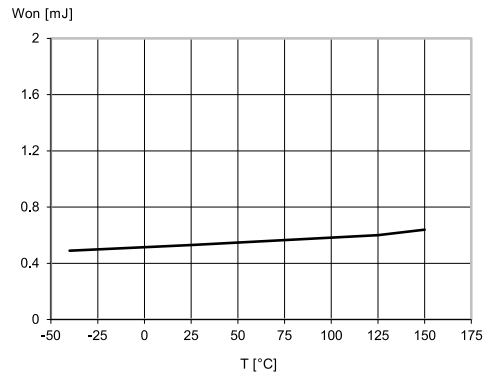

GAPG1206150833CFT

Figure 20: Woff vs Tcase

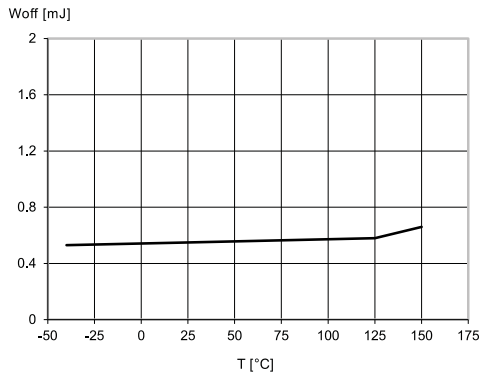

GAPG1206150834CFT

Figure 21: IlimH vs. Tcase

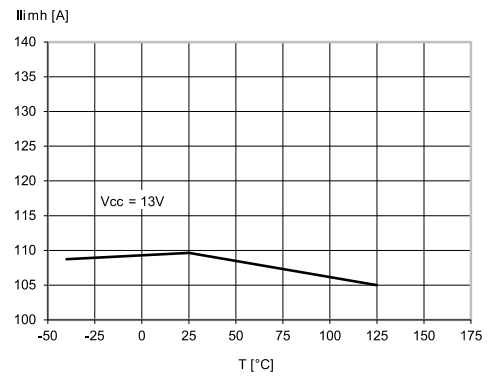

GAPG1206150835CFT

Figure 22: Turn-off output voltage clamp

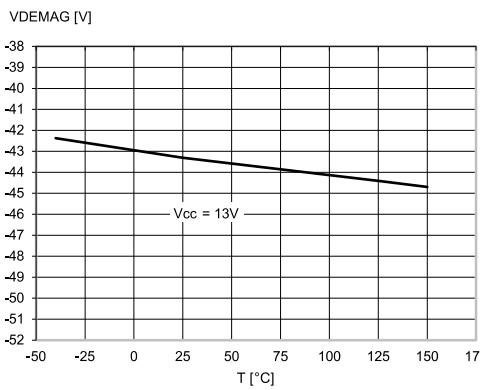

GAPG1206150836CFT

Figure 23: OFF-state open-load voltage detection threshold

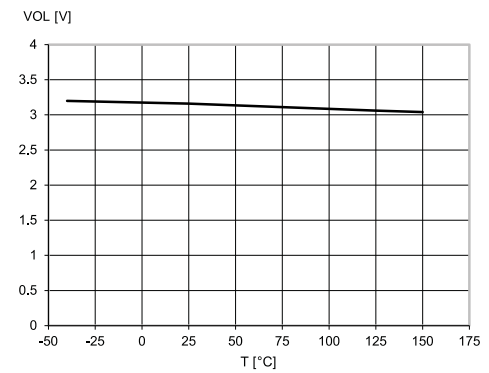

GAPG1206150837CFT

Figure 24: Vsense clamp vs Tcase

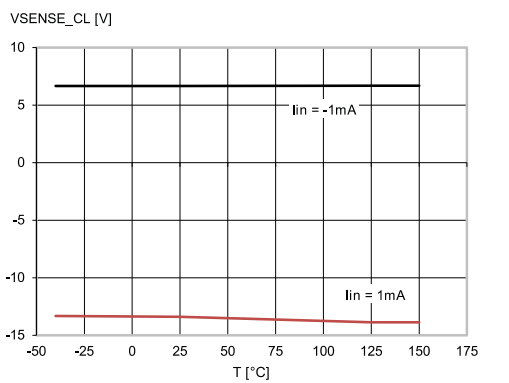

GAPG1206150839CFT

Figure 25: Vsenseh vs Tcase

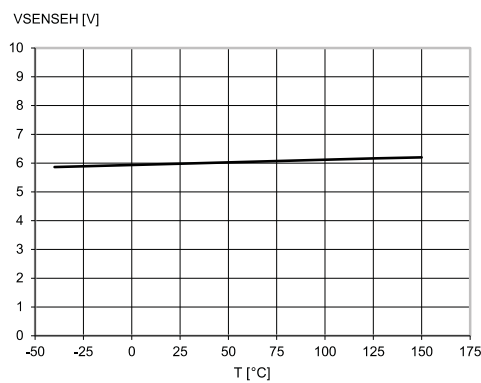

GAPG1206150840CFT

3 Protections

3.1 Power limitation

The basic working principle of this protection consists of an indirect measurement of the junction temperature swing ΔT_j through the direct measurement of the spatial temperature gradient on the device surface in order to automatically shut off the output MOSFET as soon as ΔT_j exceeds the safety level of ΔT_{j_SD} . According to the voltage level on the FR_DIAG pin, the output MOSFET switches on and cycles with a thermal hysteresis according to the maximum instantaneous power which can be handled (FR_DIAG = Low) or remains off (FR_DIAG = High). The protection prevents fast thermal transient effects and, consequently, reduces thermo-mechanical fatigue.

3.2 Thermal shutdown

In case the junction temperature of the device exceeds the maximum allowed threshold (typically 175°C), it automatically switches off and the diagnostic indication is triggered. According to the voltage level on the FR_DIAG pin, the device switches on again as soon as its junction temperature drops to T_R (FR_DIAG = Low) or remains off (FR_DIAG = High).

3.3 Current limitation

The device is equipped with an output current limiter in order to protect the silicon as well as the other components of the system (e.g. bonding wires, wiring harness, connectors, loads, etc.) from excessive current flow. Consequently, in case of short circuit, overload or during load power-up, the output current is clamped to a safety level, I_{LIMH} , by operating the output power MOSFET in the active region.

3.4 Negative voltage clamp

In case the device drives inductive load, the output voltage reaches negative value during turn off. A negative voltage clamp structure limits the maximum negative voltage to a certain value, V_{DEMAG} , allowing the inductor energy to be dissipated without damaging the device.

4 Application information

Figure 26: Application diagram

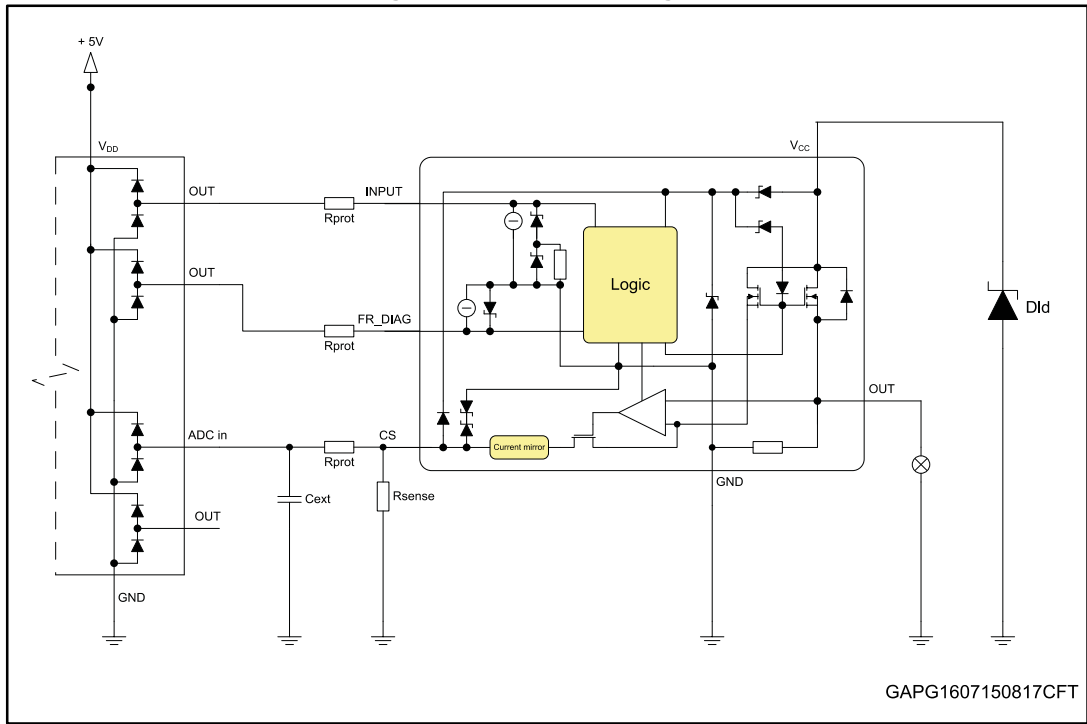

4.1 GND protection network against reverse battery

Figure 27: Simplified internal structure

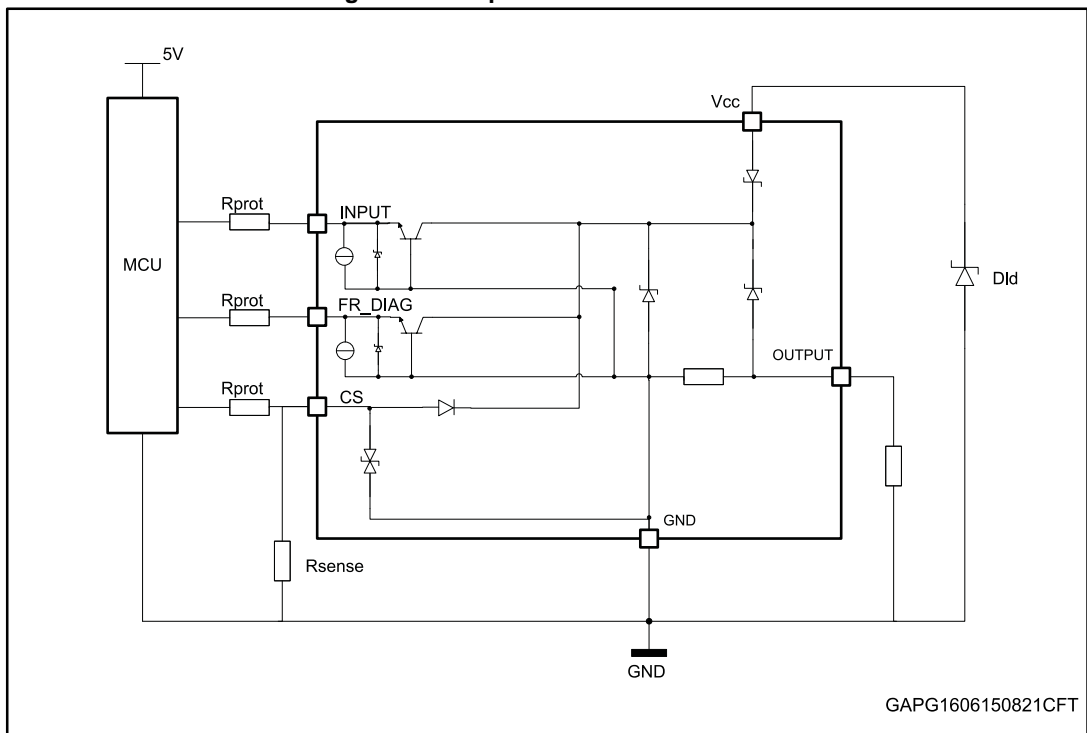

The device does not need any external components to protect the internal logic in case of a reverse battery condition. The protection is provided by internal structures.

In addition, due to the fact that the output MOSFET turns on even in reverse battery mode, thus providing the same low ohmic path as in regular operating conditions, no additional power dissipation has to be considered.

4.2 Immunity against transient electrical disturbances

The immunity of the device against transient electrical emissions, conducted along the supply lines and injected into the V_{CC} pin, is tested in accordance with ISO 7637-2:2011 (E) and ISO 16750-2:2010.

The related function performance status classification is shown in [Table 13: "ISO 7637-2 - electrical transient conduction along supply line"](#).

Test pulses are applied directly to DUT (Device Under Test) both in ON and OFF-state and in accordance to ISO 7637-2:2011(E), chapter 4. The DUT is intended as the present device only, without components and accessed through V_{CC} and GND terminals.

Status II is defined in ISO 7637-1 Function Performance Status Classification (FPSC) as follows: "The function does not perform as designed during the test but returns automatically to normal operation after the test".

Table 13: ISO 7637-2 - electrical transient conduction along supply line

Test Pulse 2011(E)	Test pulse severity level with Status II functional performance status		Minimum number of pulses or test time	Burst cycle / pulse repetition time		Pulse duration and pulse generator internal impedance
	Level	$U_s^{(1)}$		min	max	
1	III	-112V	500 pulses	0,5 s		2ms, 10 Ω
2a	III	+55V	500 pulses	0,2 s	5 s	50 μ s, 2 Ω
3a	IV	-220V	1h	90 ms	100 ms	0.1 μ s, 50 Ω
3b	IV	+150V	1h	90 ms	100 ms	0.1 μ s, 50 Ω
4 ⁽²⁾	IV	-7V	1 pulse			100ms, 0.01 Ω
Load dump according to ISO 16750-2:2010						
Test B ⁽³⁾		40V	5 pulse	1 min		400ms, 2 Ω

Notes:

⁽¹⁾ U_s is the peak amplitude as defined for each test pulse in ISO 7637-2:2011(E), chapter 5.6.

⁽²⁾Test pulse from ISO 7637-2:2004(E).

⁽³⁾With 40 V external suppressor referred to ground ($-40^{\circ}\text{C} < T_j < 150^{\circ}\text{C}$).

4.3 MCU I/Os protection

If a ground protection network is used and negative transients are present on the V_{CC} line, the control pins will be pulled negative. ST suggests to insert a resistor (R_{prot}) in line both to prevent the microcontroller I/O pins from latch-up and to protect the HSD inputs.

The value of these resistors is a compromise between the leakage current of microcontroller and the current required by the HSD I/Os (Input levels compatibility) with the latch-up limit of microcontroller I/Os.

Equation

$$V_{CCpeak}/I_{latchup} \leq R_{prot} \leq (V_{OH\mu C} - V_{IH} - V_{GND}) / I_{IHmax}$$

Calculation example:

For $V_{CCpeak} = -150\text{ V}$; $I_{latchup} \geq 20\text{ mA}$; $V_{OH\mu C} \geq 4.5\text{ V}$

$7.5\text{ k}\Omega \leq R_{prot} \leq 140\text{ k}\Omega$.

Recommended values: $R_{prot} = 15\text{ k}\Omega$

4.4 CS - analog current sense

Diagnostic information on device and load status are provided by an analog output pin (CS) delivering the following signal:

- Current monitor: current monitor of channel output current

Figure 28: CurrentSense and diagnostic – block diagram

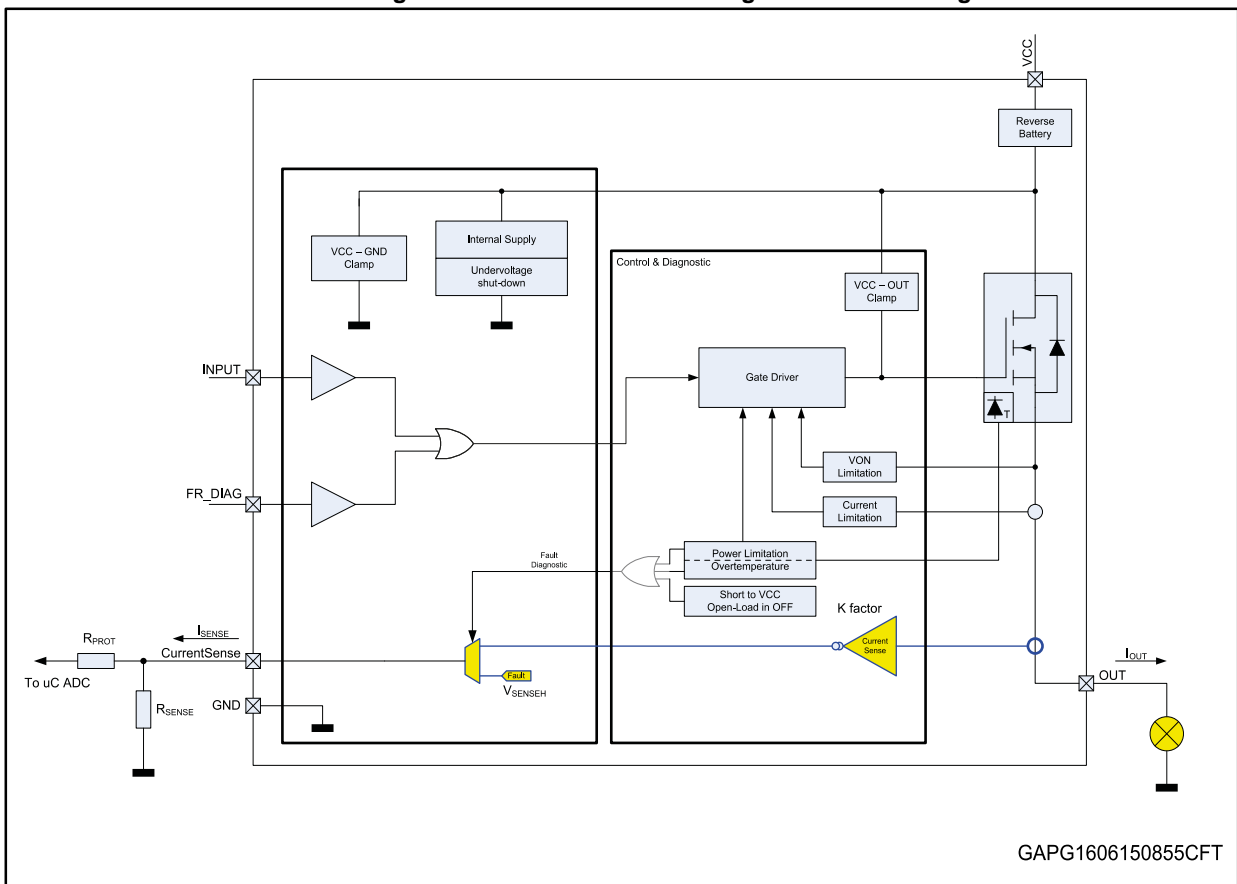

4.4.1 Principle of CurrentSense signal generation

Figure 29: CurrentSense block diagram

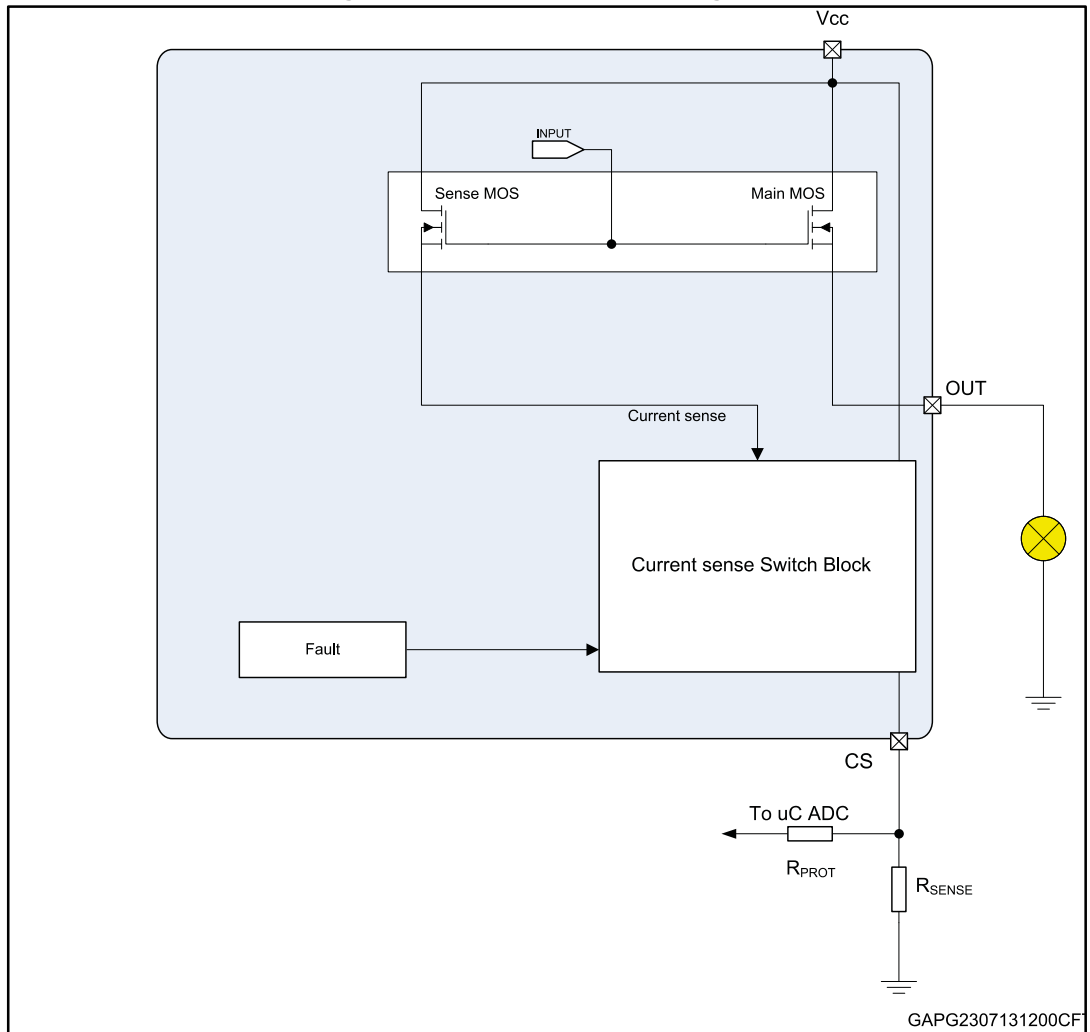

Current sense

This output is capable to provide:

- **Current mirror proportional to the load current in normal operation**, delivering current proportional to the load according to known ratio named **K**
- **Diagnostics flag in fault conditions** delivering fixed voltage V_{SENSEH}

The current delivered by the current sense circuit, I_{SENSE} , can be easily converted to a voltage V_{SENSE} by using an external sense resistor, R_{SENSE} , allowing continuous load monitoring and abnormal condition detection.

Normal operation (channel ON, no fault)

While device is operating in normal conditions (no fault intervention), V_{SENSE} calculation can be done using simple equations

Current provided by CurrentSense output: $I_{SENSE} = I_{OUT}/K$

Voltage on R_{SENSE} : $V_{SENSE} = R_{SENSE} \cdot I_{SENSE} = R_{SENSE} \cdot I_{OUT}/K$

Where :

- V_{SENSE} is voltage measurable on R_{SENSE} resistor
- I_{SENSE} is current provided from CS pin in current output mode
- I_{OUT} is current flowing through output
- K factor represent the ratio between PowerMOS cells and SenseMOS cells; its spread includes geometric factor spread, current sense amplifier offset and process parameters spread of overall circuitry specifying ratio between I_{OUT} and I_{SENSE} .

Failure flag indication

In case of power limitation/overtemperature, the fault is indicated by the CS pin which is switched to a “current limited” voltage source, V_{SENSEH} .

In any case, the current sourced by the CS in this condition is limited to I_{SENSEH} .

Figure 30: Analogue HSD – open-load detection in off-state

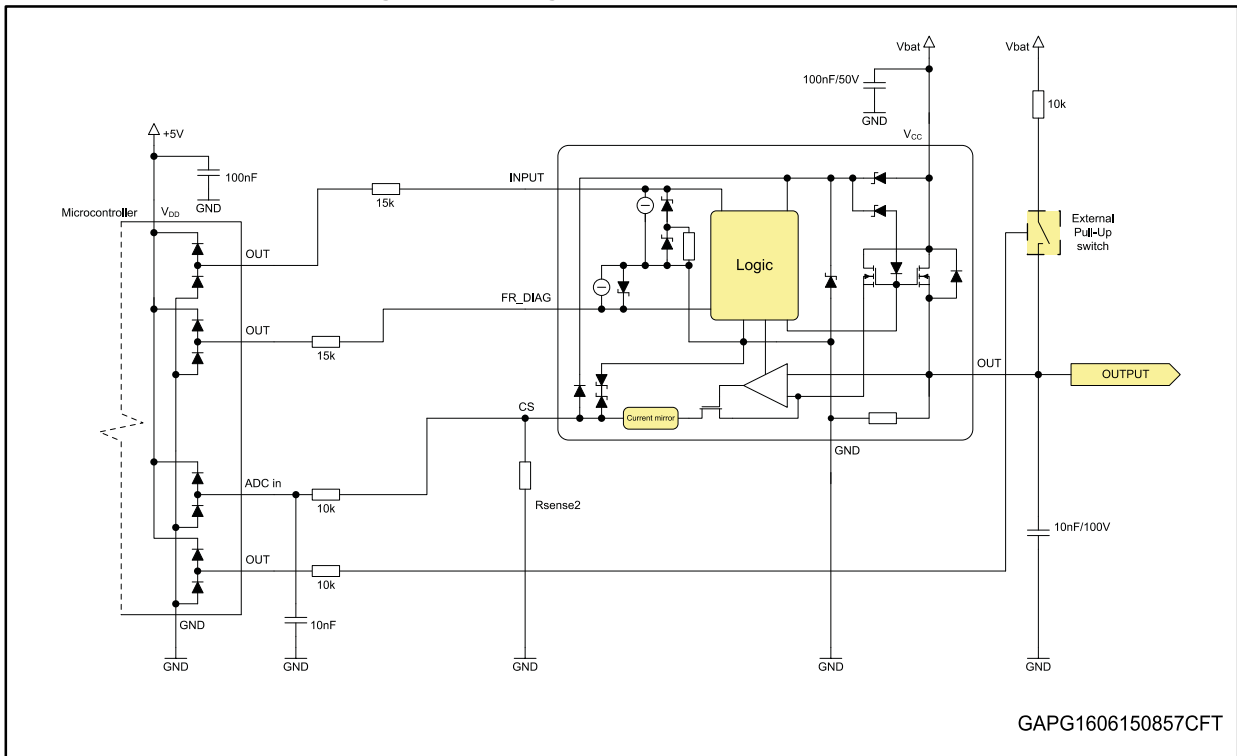
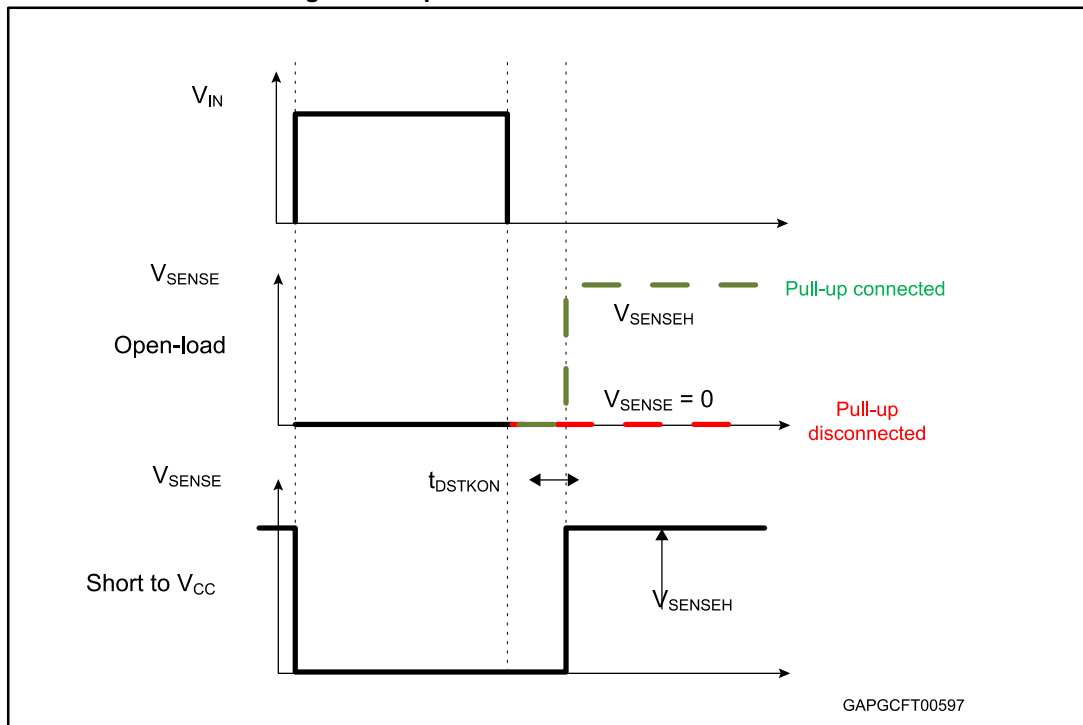

Figure 31: Open-load / short to VCC condition



GAPGCFT00597

Table 14: CurrentSense pin levels in off-state

Condition	Output	CurrentSense	FR_DIAG
Open-load	$V_{OUT} > V_{OL}$	Hi-Z	L
	$V_{OUT} < V_{OL}$	V_{SENSEH}	H
Short to VCC	$V_{OUT} > V_{OL}$	Hi-Z	L
	$V_{OUT} < V_{OL}$	0	H
Nominal	$V_{OUT} > V_{OL}$	Hi-Z	L
	$V_{OUT} < V_{OL}$	0	H

4.4.2 Short to VCC and OFF-state open-load detection

Short to VCC

A short circuit between V_{CC} and output is indicated by the relevant current sense pin set to V_{SENSEH} during the device off-state. Small or no current is delivered by the current sense during the on-state depending on the nature of the short circuit.

OFF-state open-load with external circuitry

Detection of an open-load in off mode requires an external pull-up resistor R_{PU} connecting the output to a positive supply voltage V_{PU} .

It is preferable V_{PU} to be switched off during the module standby mode in order to avoid the overall standby current consumption to increase in normal conditions, i.e. when load is connected.

R_{PU} must be selected in order to ensure $V_{OUT} > V_{OLmax}$ in accordance with the following equation:

Equation

$$R_{PU} < \frac{V_{PU} - 4}{I_{L(off2)min @ 4V}}$$

5 Maximum demagnetization energy (VCC = 16 V)

Figure 32: Maximum turn off current versus inductance

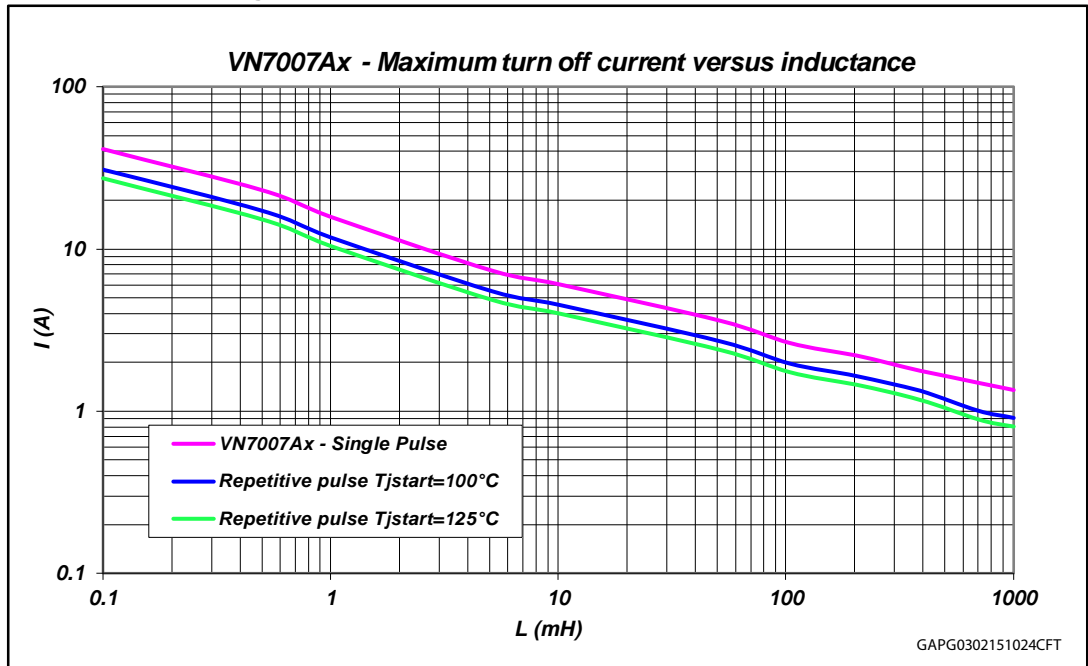

Values are generated with $R_L = 0 \Omega$.

In case of repetitive pulses, T_{jstart} (at the beginning of each demagnetization) of every pulse must not exceed the temperature specified above for curves A and B.

6 Package and PCB thermal data

6.1 Octapak thermal data

Figure 33: Octapak on two-layers PCB (2s0p to JEDEC JESD 51-5)

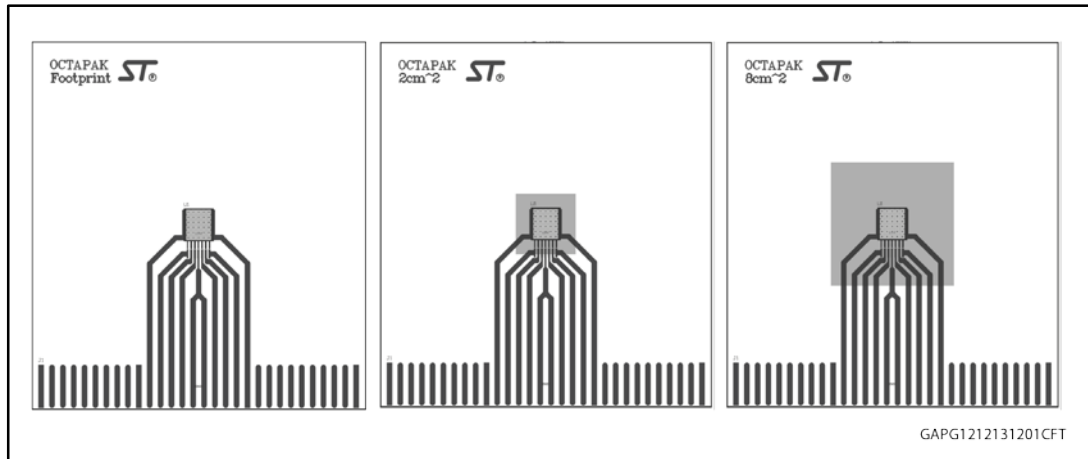

Figure 34: Octapak on four-layers PCB (2s2p to JEDEC JESD 51-7)

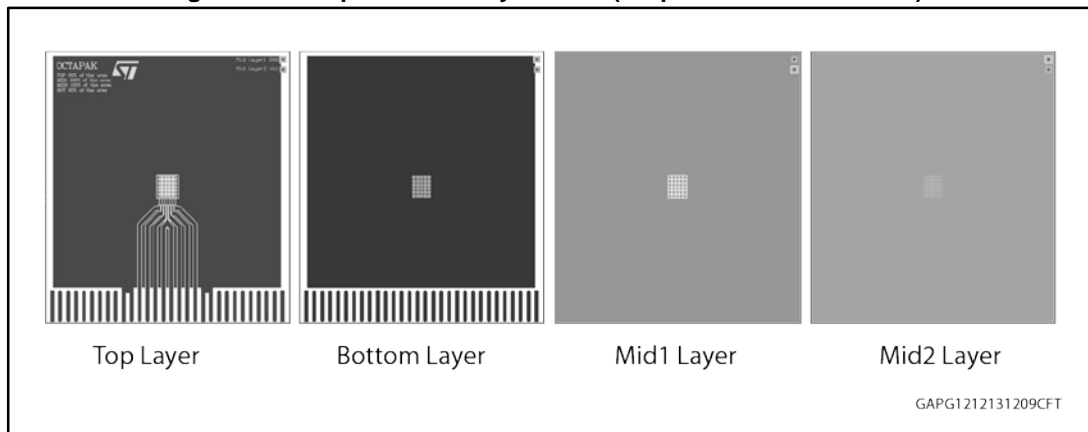

Table 15: PCB properties

Dimension	Value
Board finish thickness	1.6 mm +/- 10%
Board dimension	77 mm x 86 mm
Board Material	FR4
Copper thickness (top and bottom layers)	0.070 mm
Copper thickness (inner layers)	0.035 mm
Thermal via separation	1.2 mm
Thermal via diameter	0.3 mm +/- 0.08 mm
Copper thickness on vias	0.025 mm
Footprint dimension (top layer)	6.4 mm x 7 mm
Heatsink copper area dimension (bottom layer)	Footprint, 2 cm ² or 8 cm ²

Figure 35: Rthj-amb vs PCB copper area in open box free air conditions

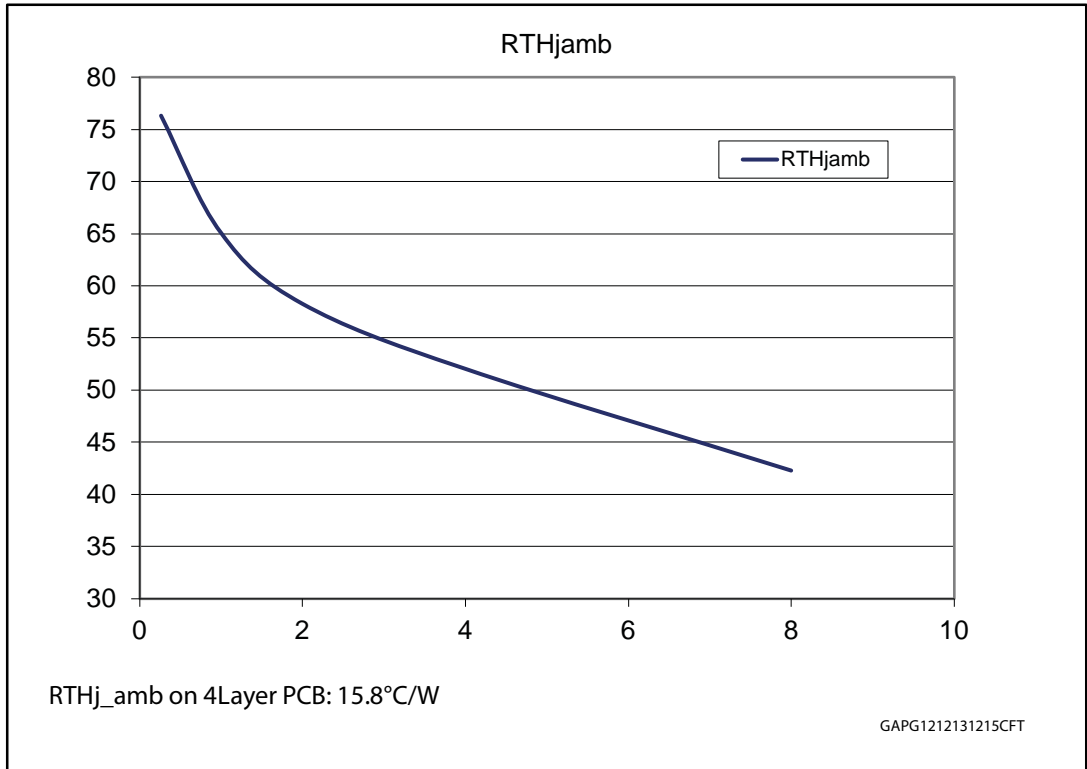
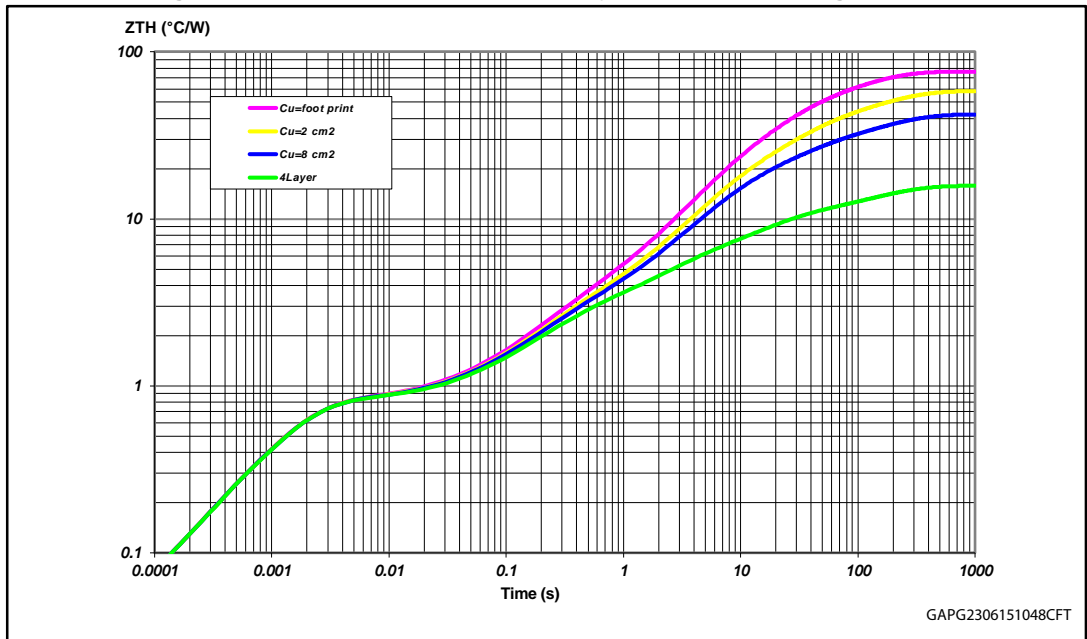

Figure 36: Octapak thermal impedance junction ambient single pulse



Equation: pulse calculation formula

$$Z_{TH\delta} = R_{TH} \cdot \delta + Z_{THtp} (1 - \delta)$$

where $\delta = t_p/T$

Figure 37: Thermal fitting model for Octapak

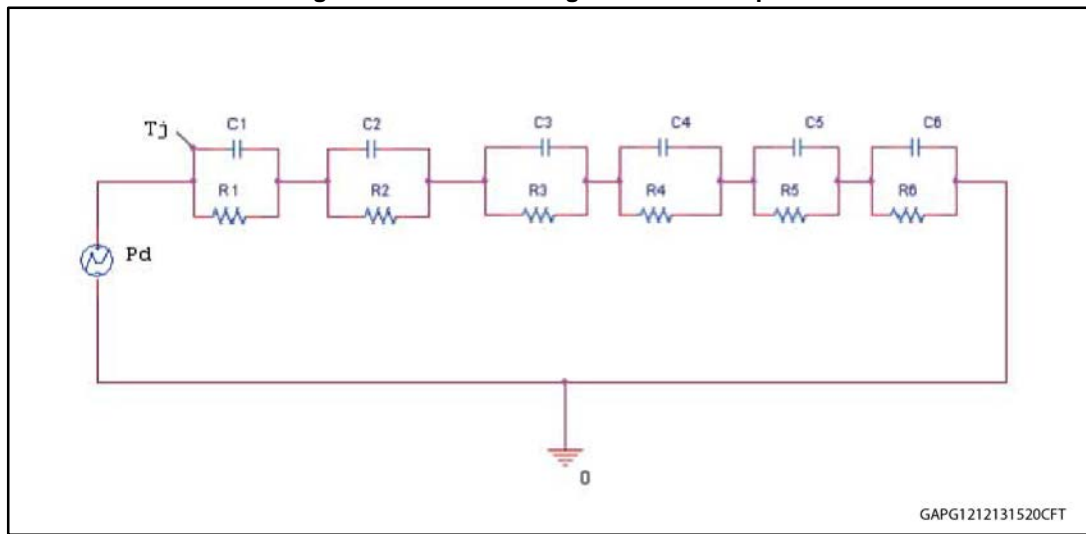

The fitting model is a simplified thermal tool and is valid for transient evolutions where the embedded protections (power limitation or thermal cycling during thermal shutdown) are not triggered.

Thermal parameters

Area/island (cm ²)	Footprint	2	8	4L
R1 (°C/W)	0.2	0.2	0.2	0.2
R2 (°C/W)	0.78	0.78	0.78	0.78
R3 (°C/W)	1.5	1.5	1.5	1.5
R4 (°C/W)	10	10	10	2.5
R5 (°C/W)	28	20	12	5
R6 (°C/W)	36	26	18	6
C1 (W.s/°C)	0.0015	0.0015	0.0015	0.0015
C2 (W.s/°C)	0.0018	0.0018	0.0018	0.0018
C3 (W.s/°C)	0.15	0.15	0.15	0.15
C4 (W.s/°C)	0.6	0.6	0.6	0.8
C5 (W.s/°C)	0.8	1.4	2.2	3
C6 (W.s/°C)	3	6	9	25

7 Package information

In order to meet environmental requirements, ST offers these devices in different grades of ECOPACK® packages, depending on their level of environmental compliance. ECOPACK® specifications, grade definitions and product status are available at: www.st.com. ECOPACK® is an ST trademark.

7.1 Octapak package information

Figure 38: Octapak package dimensions

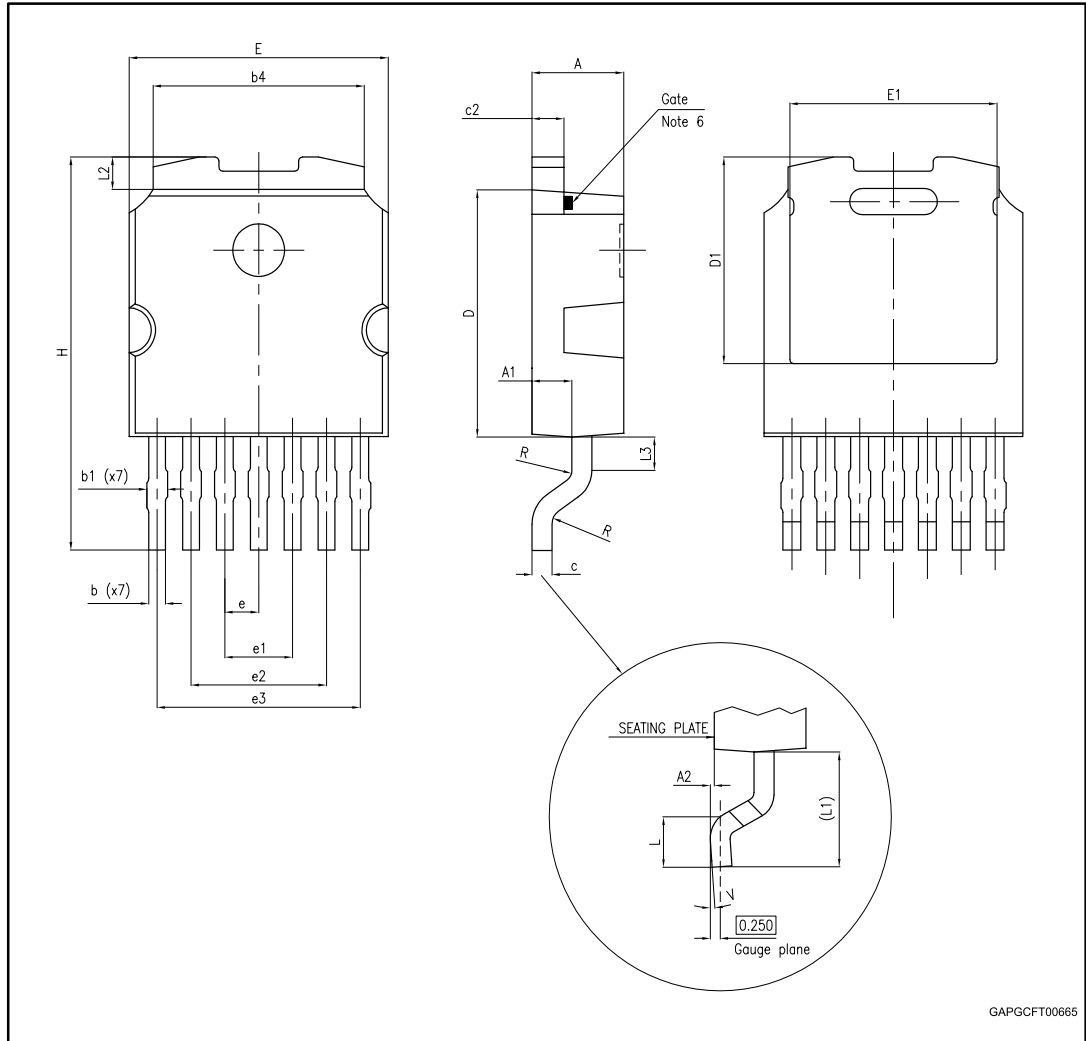

Table 16: Octapak mechanical data

Symbol	Millimeters		
	Min.	Typ.	Max.
A	2.20	2.30	2.40
A1	0.90	1.00	1.10
A2	0.03		0.15
b	0.38	0.45	0.52
b1			0.70
b4	5.20	5.30	5.40
c	0.45	0.50	0.60
c2	0.75	0.80	0.90
D	6.00	6.10	6.20
D1		5.15	
E	6.40	6.50	6.60
E1		5.30	
e	0.85 BSC		
e1	1.60	1.70	1.80
e2	3.30	3.40	3.50
e3	5.00	5.10	5.20
H	9.35	9.70	10.10
L	1.00		—
(L1)		2.80	
L2		0.80	
L3		0.85	
R	0.40 BSC		
V2	0°		8°

7.2 Octapak packing information

Figure 39: Octapak reel 13"

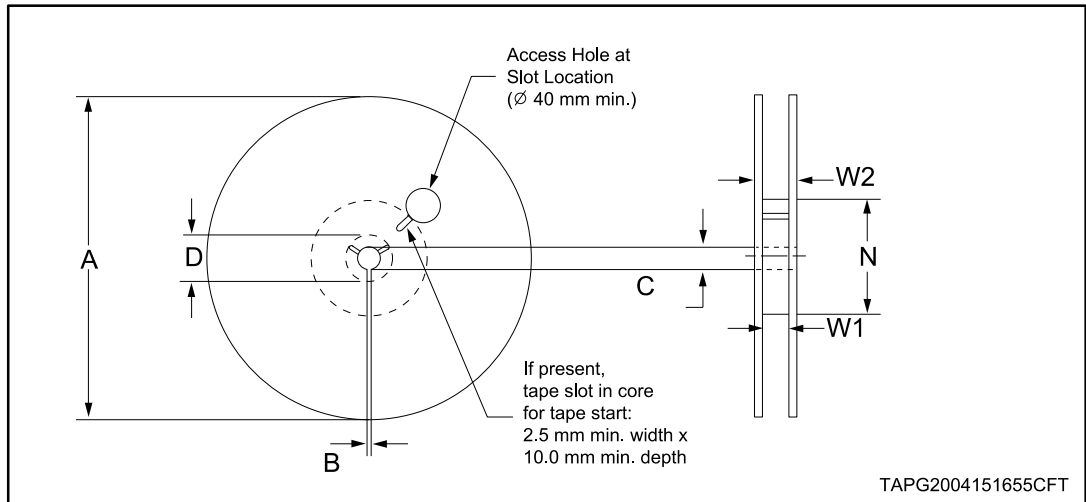

Table 17: Reel dimensions

Description	Value ⁽¹⁾
Base quantity	2500
Bulk quantity	2500
A (max)	330
B (min)	1.5
C (+0.5, -0.2)	13
D	20.2
N	100
W1 (+2 /-0)	16.4
W2 (max)	22.4

Notes:

⁽¹⁾All dimensions are in mm.

Figure 40: Octapak carrier tape

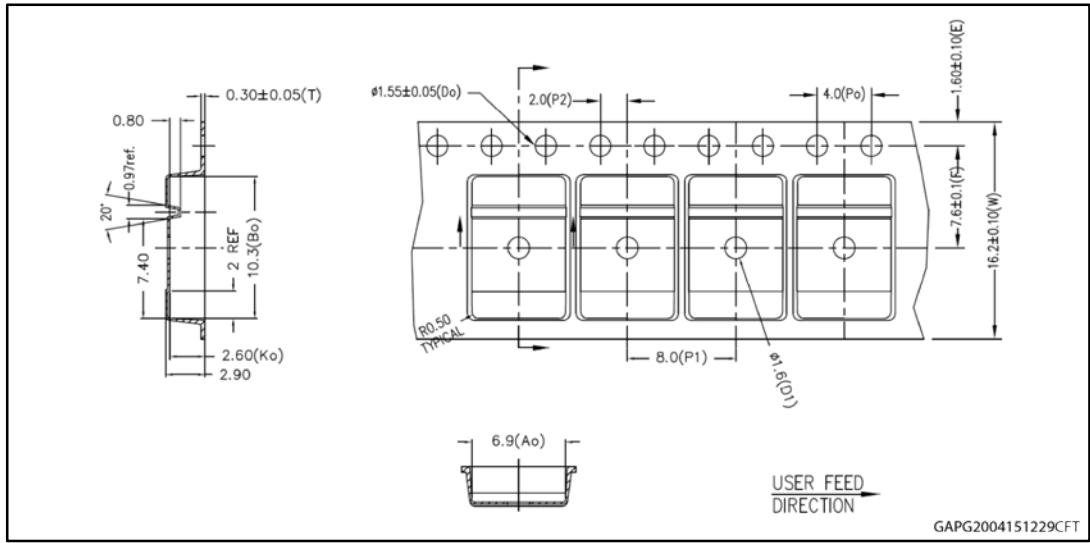
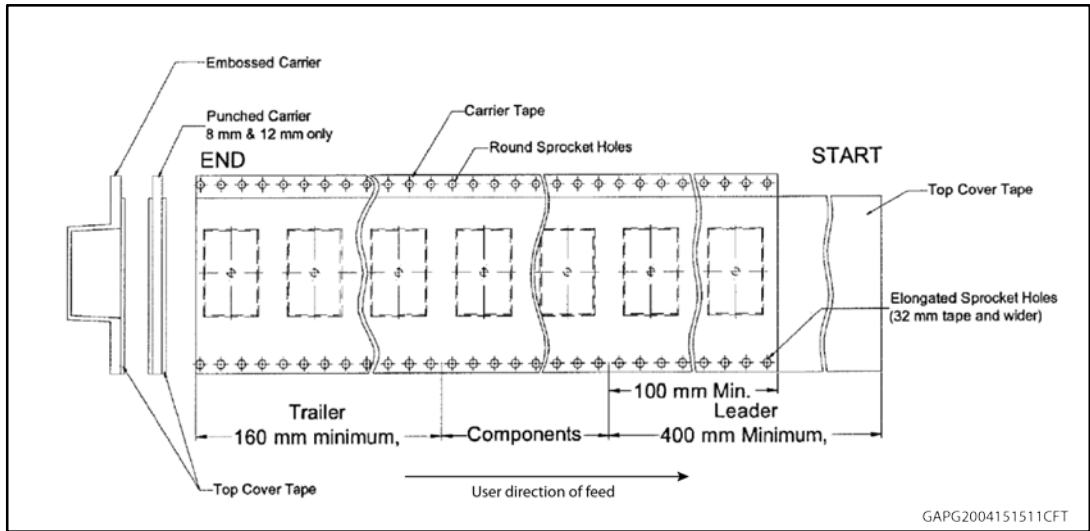
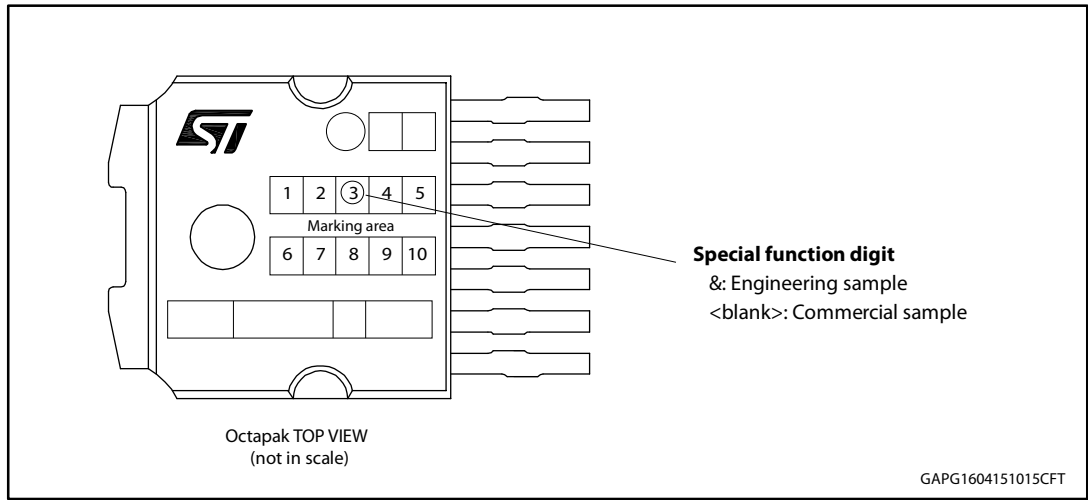

Figure 41: Octapak schematic drawing of leader and trailer tape



7.3 Octapak marking information

Figure 42: Octapak marking information



Engineering Samples: these samples can be clearly identified by a dedicated special symbol in the marking of each unit. These samples are intended to be used for electrical compatibility evaluation only; usage for any other purpose may be agreed only upon written authorization by ST. ST is not liable for any customer usage in production and/or in reliability qualification trials.

Commercial Samples: fully qualified parts from ST standard production with no usage restrictions.

8 Revision history

Table 18: Document revision history

Date	Revision	Changes
22-Jun-2015	1	Initial release.

IMPORTANT NOTICE – PLEASE READ CAREFULLY

STMicroelectronics NV and its subsidiaries ("ST") reserve the right to make changes, corrections, enhancements, modifications, and improvements to ST products and/or to this document at any time without notice. Purchasers should obtain the latest relevant information on ST products before placing orders. ST products are sold pursuant to ST's terms and conditions of sale in place at the time of order acknowledgement.

Purchasers are solely responsible for the choice, selection, and use of ST products and ST assumes no liability for application assistance or the design of Purchasers' products.

No license, express or implied, to any intellectual property right is granted by ST herein.

Resale of ST products with provisions different from the information set forth herein shall void any warranty granted by ST for such product.

ST and the ST logo are trademarks of ST. All other product or service names are the property of their respective owners.

Information in this document supersedes and replaces information previously supplied in any prior versions of this document.

© 2015 STMicroelectronics – All rights reserved