

Silicon PNP Power Transistors

2N6420

DESCRIPTION

- With TO-66 package
- Continuous collector current- $I_C=-1A$
- Power dissipation - $P_D=35W$ @ $T_C=25$
- Complement to type 2N3583

APPLICATIONS

- High speed switching and linear amplifier
- High-voltage operational amplifiers
- Switching regulators ,converters
- Deflection stages and high fidelity amplifiers

PINNING (See Fig.2)

PIN	DESCRIPTION
1	Base
2	Emitter
3	Collector

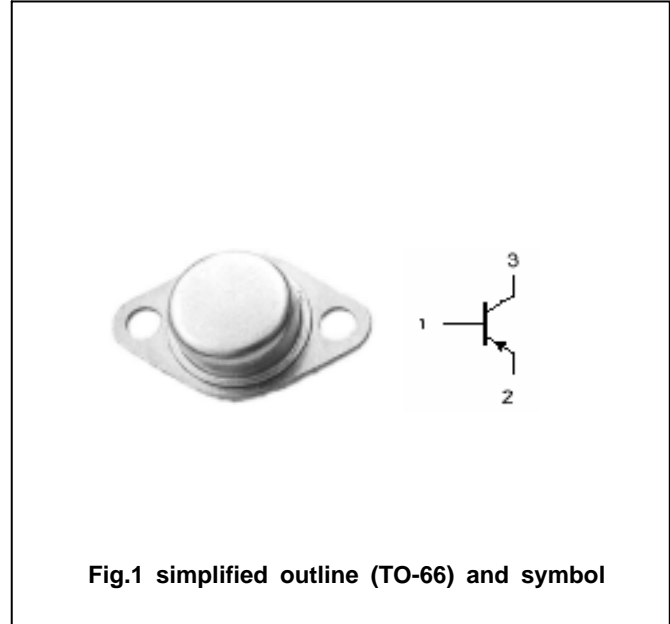
Absolute maximum ratings($T_a=25$)

SYMBOL	PARAMETER	CONDITIONS	VALUE	UNIT
V_{CBO}	Collector-base voltage	Open emitter	-250	V
V_{CEO}	Collector-emitter voltage	Open base	-175	V
V_{EBO}	Emitter-base voltage	Open collector	-6	V
I_C	Collector current		-1.0	A
I_{CM}	Collector current-Peak		-5.0	A
I_B	Base current		-1.0	A
P_T	Total power dissipation	$T_C=25$	35	W
T_j	Junction temperature		200	
T_{stg}	Storage temperature		-65~200	

THERMAL CHARACTERISTICS

SYMBOL	PARAMETER	MAX	UNIT
$R_{th j-C}$	Thermal resistance junction to case	5.0	/W

Silicon PNP Power Transistors

2N6420

CHARACTERISTICS

T_j=25 unless otherwise specified

SYMBOL	PARAMETER	CONDITIONS	MIN	TYP.	MAX	UNIT
V _{CEO(SUS)}	Collector-emitter sustaining voltage	I _C =-50mA ; I _B =0	-175			V
V _{CEsat}	Collector-emitter saturation voltage	I _C =-1A ; I _B =-0.125A			-5.0	V
V _{BE}	Base -emitter on voltage	I _C =-1A ; V _{CE} =-10V			-1.4	V
I _{CEx}	Collector cut-off current	V _{CE} =-225V ; V _{BE(off)} =-1.5V T _C =150			-1.0 -3.0	mA
I _{CEO}	Collector cut-off current	V _{CE} =-150V I _B =0			-10	mA
I _{EBO}	Emitter cut-off current	V _{EB} =-6V ; I _C =0			-5.0	mA
h _{FE-1}	DC current gain	I _C =-0.1A ; V _{CE} =-10V	40			
h _{FE-2}	DC current gain	I _C =-0.5A ; V _{CE} =-10V	40		200	
h _{FE-3}	DC current gain	I _C =-1A ; V _{CE} =-10V	10			

Silicon PNP Power Transistors

2N6420

PACKAGE OUTLINE

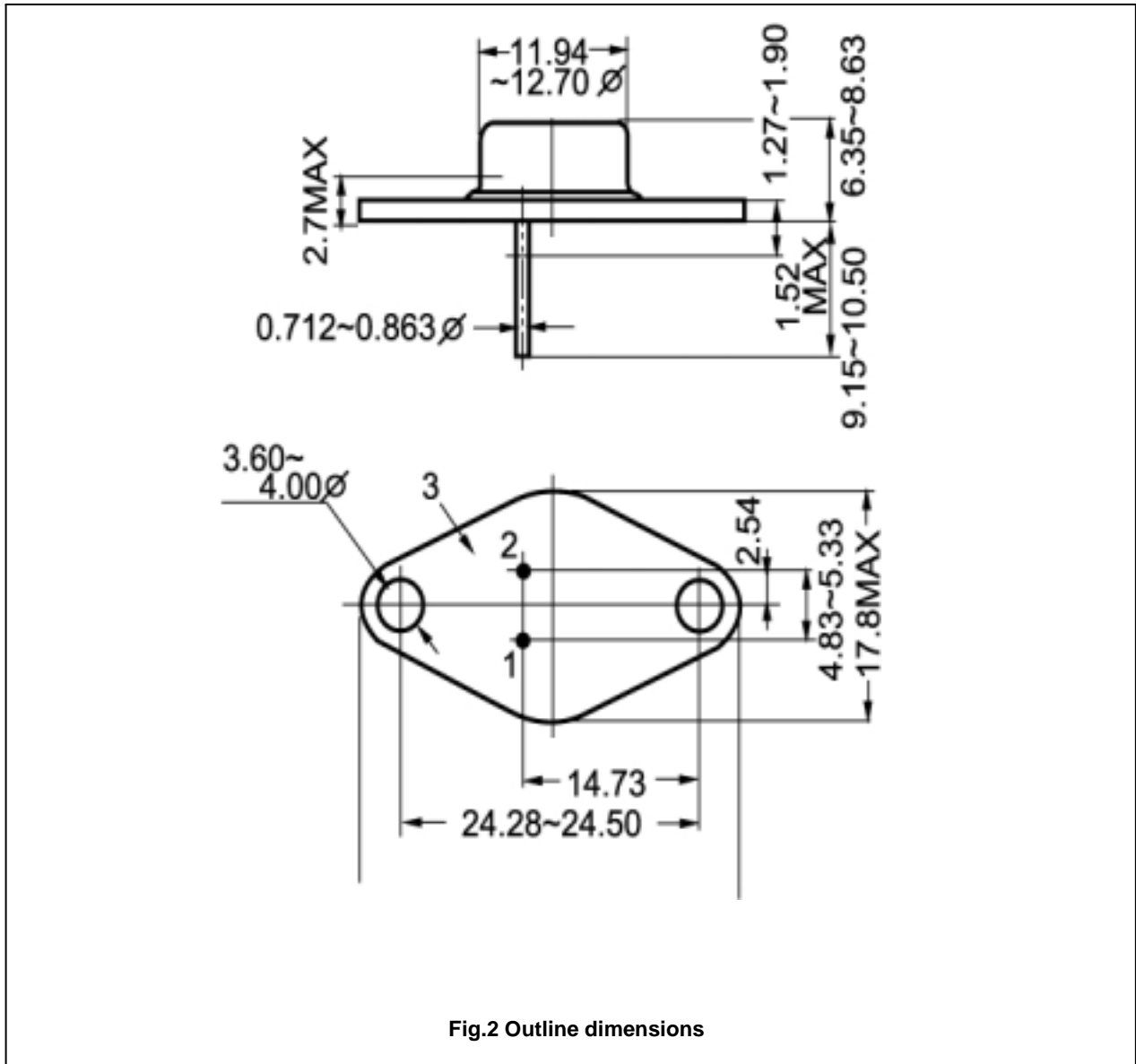

Fig.2 Outline dimensions