

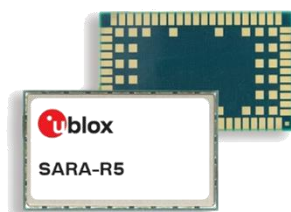

SARA-R5 series

LTE-M / NB-IoT modules with secure cloud

Data sheet



Abstract

Technical data sheet describing SARA-R5 LTE-M / NB-IoT modules, based on the u-blox UBX-R5 cellular chipset. The modules are a size-optimized solution specifically designed for IoT, integrating an in-house developed cellular modem, end-to-end trusted domain security, and u-blox's leading GNSS technology. The modules deliver high performance satellite positioning alongside data connectivity in the very small and compact SARA form factor.



Document Information

Title	SARA-R5 series	
Subtitle	LTE-M / NB-IoT modules with secure cloud	
Document type	Data sheet	
Document number	UBX-19016638	
Revision and date	R06	15-Jul-2020
Disclosure Restriction	C1-Public	

Product status	Corresponding content status	
Functional sample	Draft	For functional testing. Revised and supplementary data will be published later.
In development / Prototype	Objective specification	Target values. Revised and supplementary data will be published later.
Engineering sample	Advance information	Data based on early testing. Revised and supplementary data will be published later.
Initial production	Early production information	Data from product verification. Revised and supplementary data may be published later.
Mass production / End of life	Production information	Document contains the final product specification.

This document applies to the following products:

Product name	Type number	Modem version	Application version	PCN reference	Product status
SARA-R500S	SARA-R500S-00B-00	02.03	A00.01	UBX-20014246	Engineering sample
SARA-R510S	SARA-R510S-00B-00	02.03	A00.01	UBX-20014246	Engineering sample
SARA-R510M8S	SARA-R510M8S-00B-00	02.03	A00.01	UBX-20014246	Engineering sample

u-blox or third parties may hold intellectual property rights in the products, names, logos and designs included in this document. Copying, reproduction, modification or disclosure to third parties of this document or any part thereof is only permitted with the express written permission of u-blox.

The information contained herein is provided "as is" and u-blox assumes no liability for its use. No warranty, either express or implied, is given, including but not limited to, with respect to the accuracy, correctness, reliability and fitness for a particular purpose of the information. This document may be revised by u-blox at any time without notice. For the most recent documents, visit www.u-blox.com.

Copyright © u-blox AG.

Contents

Document Information	2
Contents	3
1 Functional description	5
1.1 Overview	5
1.2 Product features	6
1.3 Block diagram	6
1.4 Product description	8
1.5 AT command support	9
1.6 Supported features	9
2 Interfaces	12
2.1 Power management	12
2.1.1 Module supply input (VCC)	12
2.1.2 Generic digital interfaces supply output (V_INT)	12
2.2 Antenna interface	12
2.2.1 Cellular antenna RF interface (ANT).....	12
2.2.2 GNSS antenna RF interface (ANT_GNSS).....	12
2.2.3 Antenna detection (ANT_DET)	12
2.3 System functions.....	13
2.3.1 Module power-on	13
2.3.2 Module power-off.....	13
2.3.3 Module reset	14
2.4 SIM	14
2.4.1 SIM interface	14
2.4.2 SIM detection	14
2.5 Serial communication	14
2.5.1 UART interfaces.....	15
2.5.2 USB interface.....	16
2.5.3 SPI interfaces	16
2.5.4 SDIO interface	17
2.5.5 DDC (I2C) interface.....	17
2.6 Audio.....	17
2.7 GPIO	18
3 Pin definition	19
3.1 Pin assignment.....	19
4 Electrical specifications	24
4.1 Absolute maximum rating.....	24
4.1.1 Maximum ESD.....	24
4.2 Operating conditions.....	25
4.2.1 Operating temperature range.....	25
4.2.2 Supply/power pins	25

4.2.3	Current consumption.....	26
4.2.4	GNSS characteristics.....	27
4.2.5	LTE RF characteristics	28
4.2.6	PWR_ON pin.....	29
4.2.7	RESET_N pin.....	30
4.2.8	SIM pins	30
4.2.9	Generic Digital Interfaces pins	30
4.2.10	DDC (I2C) pins.....	31
4.2.11	USB pins	31
5	Mechanical specifications	32
6	Qualification and approvals.....	33
6.1	Reliability tests.....	33
6.1.1	Approvals.....	33
7	Product handling & soldering.....	34
7.1	Packaging	34
7.1.1	Reels	34
7.1.2	Tapes.....	35
7.2	Moisture sensitivity levels.....	36
7.3	Reflow soldering	36
7.4	ESD precautions.....	36
8	Labeling and ordering information	37
8.1	Product labeling.....	37
8.2	Explanation of codes	37
8.3	Ordering information.....	38
Appendix	39
A	Glossary	39
Related documents	42
Revision history	42
Contact		43

1 Functional description

1.1 Overview

SARA-R5 series modules are secure cloud LTE Cat M1, LTE Cat NB2 solutions based on u-blox's UBX-R5 cellular chipset. The SARA-R500 secure cloud module (called "SARA-R500S" in this data sheet) is the cost effective solution, the SARA-R510 secure cloud module (called "SARA-R510S" in this data sheet) is optimized for extremely low power consumption in deep-sleep PSM, and the SARA-R510M8 secure cloud module (called "SARA-R510M8S" in this data sheet) has an integrated u-blox M8 GNSS receiver chip and a separate GNSS antenna interface.

The miniature SARA LGA form factor (26.0 x 16.0 mm, 96-pin) allows an easy integration into compact designs and a seamless drop-in migration from other u-blox cellular module families.

SARA-R5 series modules are form-factor compatible with the u-blox LISA, LARA and TOBY cellular module families and they are pin-to-pin compatible with the u-blox SARA-R4, SARA-N2, SARA-N3, SARA-N4, SARA-G3, SARA-G4 and SARA-U2 cellular modules families. This facilitates migration from other u-blox LPWA modules as well as from other u-blox GSM/GPRS, CDMA, UMTS/HSPA and higher LTE categories modules, maximizing customer investments, simplifying logistics, and enabling very short time-to-market.

SARA-R5 series modules provide software-based multi-band configurability enabling international multi-regional coverage in LTE Cat M1 / NB2 radio access technologies, supporting a comprehensive set of 3GPP Rel. 14 features that are relevant for IoT applications.

SARA-R5 series modules offer data communications up to 1200 kbit/s over an extended operating temperature range of -40 °C to +85 °C, with low power consumption, and with coverage enhancement for deeper range into buildings and basements (and underground with NB2).

With a discrete, hardware-based secure element and a lightweight pre-shared key management system, u-blox offers state-of-the-art security that is ideal for IoT applications and includes local data protection, zero touch provisioning, anti-cloning, and local secure chip-to-chip communication. With many interface options and an integrated IP stack, SARA-R5 series modules are the optimal choice for LPWA applications with low to medium data throughput rates, as well as devices that require long battery lifetimes, such as used in smart metering, smart lighting, telematics, asset tracking, remote monitoring, alarm panels, and connected healthcare.

Customers can future-proof their solutions by means of over-the-air firmware updates, thanks to the uFOTA client/server solution that utilizes LwM2M, a light and compact protocol ideal for IoT.

 The "00" products version of the SARA-R5 series modules do not support LTE NB-IoT.

1.2 Product features

Model	Region	RAT	Positioning	Interfaces	Features	Grade
		LTE category LTE FDD bands	Integrated GNSS receiver External GNSS control via modem AssistNow software CellLocate [®]	UARTs USB (for diagnostics) SPI SDIO DDC (I2C) GPIOs Digital audio (I2S)	RoT security & services: uCSP Ver 1.1 Embedded Secure Element EAL5+ High certified Antenna dynamic tuning CellTime [®] Ultra-low power consumption in PSM Embedded TCP/UDP stack Embedded HTTP, FTP Embedded TLS, DTLS FW update via serial (FOAT) u-blox Firmware update Over the Air (uFOTA) LwM2M with dynamically loaded objects Embedded MQTT, MQTT-SN Embedded CoAP Last gasp Jamming detection Antenna and SIM detection	Standard Professional Automotive
SARA-R500S	Multi Region	M1 NB2 *	• • •	• • • • • • •	• • • • • • • • • • • • • • • • • • •	•
SARA-R510S	Multi Region	M1 NB2 *	• • •	• • • • • • •	• • • • • • • • • • • • • • • • • • •	•
SARA-R510M8S	Multi Region	M1 NB2 *	• • •	• • • • • • •	• • • • • • • • • • • • • • • • • • •	•

* = LTE Bands 1, 2, 3, 4, 5, 8, 12, 13, 18, 19, 20, 26, 28 in M1 and NB2, LTE bands 25 in M1-only, and LTE bands 66, 71, 85 in NB2-only
 • = supported by all FW versions ○ = supported by future FW versions

Table 1: SARA-R5 series main features summary

📘 The “00” products version of the SARA-R5 series modules do not support LTE NB-IoT.

1.3 Block diagram

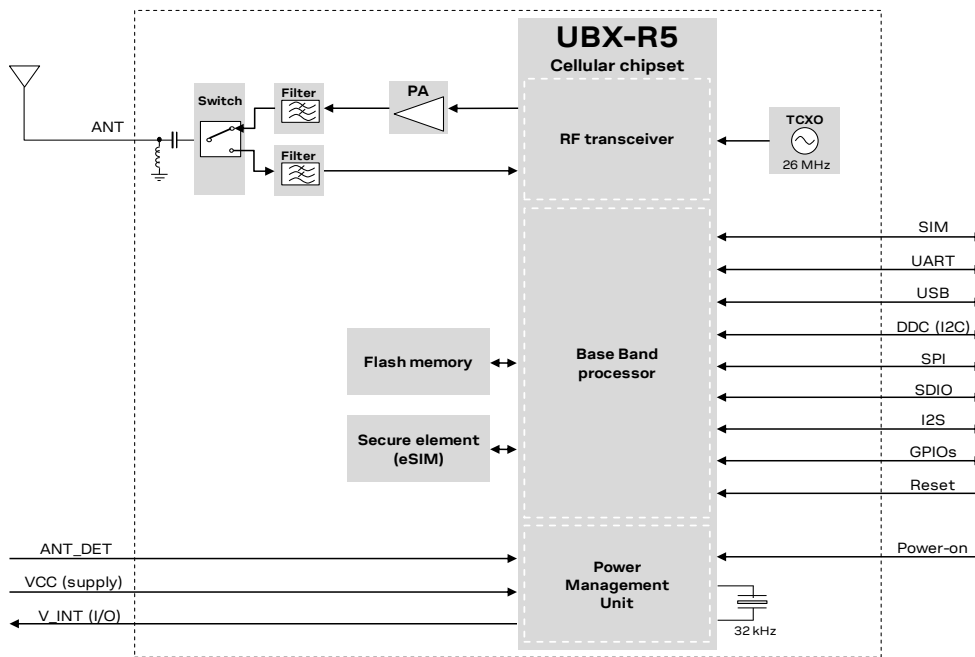

Figure 1: SARA-R500S block diagram

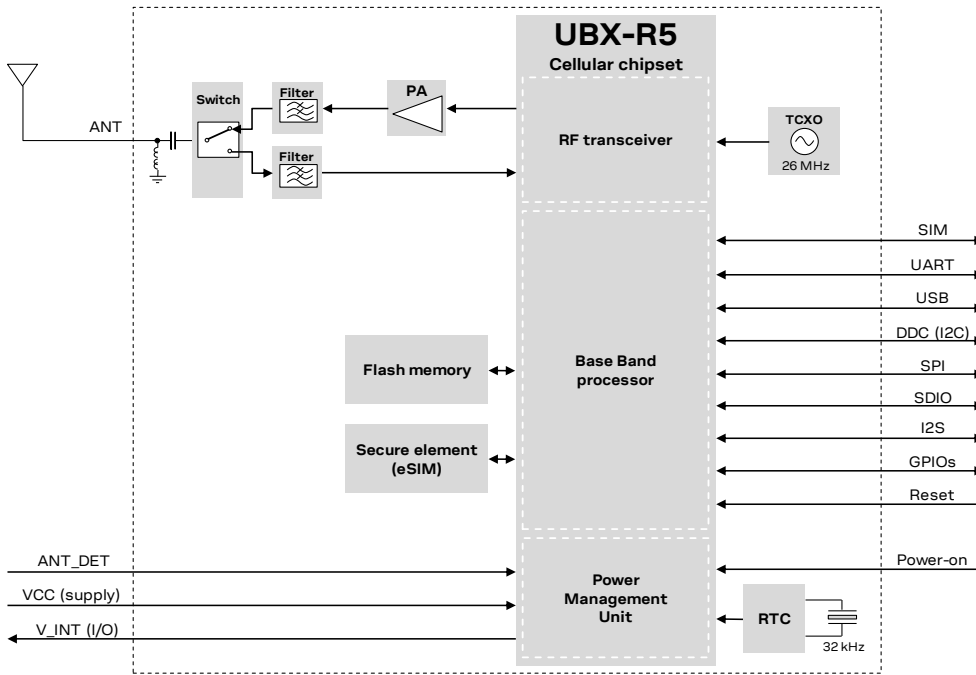

Figure 2: SARA-R510S block diagram

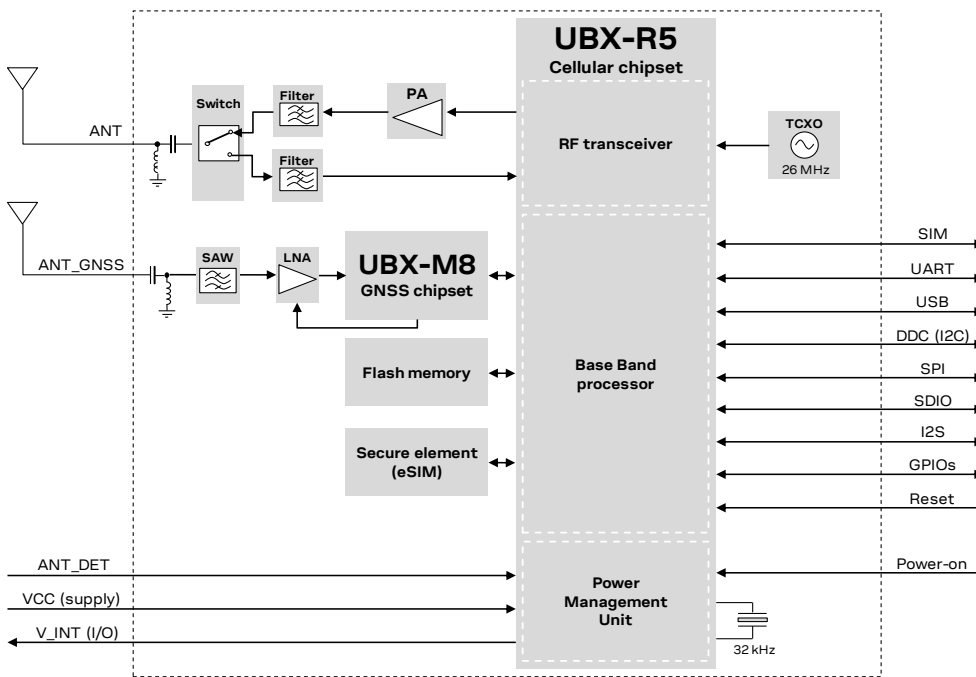

Figure 3: SARA-R510M8S block diagram

The “00” products version of the SARA-R5 series modules, do not support the following interfaces, which should be left unconnected and should not be driven by external devices:

- SPI interface
- SDIO interface
- Digital audio (I2S) interface

1.4 Product description

SARA-R5 series modules include the following variants / products versions:

- SARA-R500S LTE Cat M1 / NB2 module for multi-region use, cost effective solution for devices that do not need to reach ultra-low power consumption in deep-sleep power saving mode (PSM)
- SARA-R510S LTE Cat M1 / NB2 module for multi-region use, designed to achieve extremely low current consumption in deep-sleep power saving mode (PSM)
- SARA-R510M8S LTE Cat M1 / NB2 module for multi-region use, integrating the UBX-M8030 high performance standard precision concurrent GNSS chip for global position acquisition

Item	SARA-R500S / SARA-R510S	SARA-R510M8S
Cellular protocol stack	3GPP Release 13 LTE Cat M1 and NB1 3GPP Release 14 LTE Cat M1: Coverage Enhancement Mode B, Uplink TBS of 2984b 3GPP Release 14 LTE Cat NB2: Higher data rate (TBS of 2536b), Mobility enhancement (RRC connection re-establishment), E-Cell ID, Lower power class PC6 (14dBm), two HARQ processes, Release Assistant, Random access on Non-Anchor Carrier	3GPP Release 13 LTE Cat M1 and NB1 3GPP Release 14 LTE Cat M1: Coverage Enhancement Mode B, Uplink TBS of 2984b 3GPP Release 14 LTE Cat NB2: Higher data rate (TBS of 2536b), Mobility enhancement (RRC connection re-establishment), E-Cell ID, Lower power class PC6 (14dBm), two HARQ processes, Release Assistant, Random access on Non-Anchor Carrier
Cellular Radio Access Technology	LTE Cat M1 Half-Duplex LTE Cat NB2 Half-Duplex	LTE Cat M1 Half-Duplex LTE Cat NB2 Half-Duplex
Cellular operating bands	LTE FDD band 1 (2100 MHz) LTE FDD band 2 (1900 MHz) LTE FDD band 3 (1800 MHz) LTE FDD band 4 (1700 MHz) LTE FDD band 5 (850 MHz) LTE FDD band 8 (900 MHz) LTE FDD band 12 (700 MHz) LTE FDD band 13 (750 MHz) LTE FDD band 18 (850 MHz) LTE FDD band 19 (850 MHz) LTE FDD band 20 (800 MHz) LTE FDD band 25 (1900 MHz) ¹ LTE FDD band 26 (850 MHz) LTE FDD band 28 (700 MHz) LTE FDD band 66 (1700 MHz) ² LTE FDD band 71 (600 MHz) ² LTE FDD band 85 (700 MHz) ²	LTE FDD band 1 (2100 MHz) LTE FDD band 2 (1900 MHz) LTE FDD band 3 (1800 MHz) LTE FDD band 4 (1700 MHz) LTE FDD band 5 (850 MHz) LTE FDD band 8 (900 MHz) LTE FDD band 12 (700 MHz) LTE FDD band 13 (750 MHz) LTE FDD band 18 (850 MHz) LTE FDD band 19 (850 MHz) LTE FDD band 20 (800 MHz) LTE FDD band 25 (1900 MHz) ¹ LTE FDD band 26 (850 MHz) LTE FDD band 28 (700 MHz) LTE FDD band 66 (1700 MHz) ² LTE FDD band 71 (600 MHz) ² LTE FDD band 85 (700 MHz) ²
Cellular power class	LTE power class 3 (23 dBm)	LTE power class 3 (23 dBm)
Cellular data rate	LTE category M1: up to 1200 kbit/s UL up to 375 kbit/s DL LTE category NB2: up to 140 kbit/s UL up to 125 kbit/s DL	LTE category M1: up to 1200 kbit/s UL up to 375 kbit/s DL LTE category NB2: up to 140 kbit/s UL up to 125 kbit/s DL
GNSS receiver type	-	72-channel u-blox M8 engine GPS L1C/A, SBAS L1C/A, QZSS L1C/A, QZSS L1-SAIF, GLONASS L10F, BeiDou B1I, Galileo E1B/C

Table 2: SARA-R5 series cellular and GNSS main characteristics



The “00” products version of the SARA-R5 series modules do not support LTE NB-IoT.

¹ Not supported in LTE category NB2

² Not supported in LTE category M1

1.5 AT command support

The SARA-R5 series modules support AT commands according to the 3GPP standards TS 27.007 [4], TS 27.005 [5], TS 27.010 [6], and the u-blox AT commands extension.

 For the complete list of all supported AT commands and their syntax, see SARA-R5 series AT commands manual [1].

1.6 Supported features

Table 3 lists some of the main features supported by SARA-R5 series modules. For more details, see the SARA-R5 series system integration manual [2] and SARA-R5 series AT commands manual [1].

Feature	Description
Device security	<p>An immutable chip ID and hardware-based Root of Trust (RoT) embedded in a dedicated Common Criteria EAL5+ high certified secure element provide foundational security and a unique device identity.</p> <p>Device security features include:</p> <ul style="list-style-type: none"> • Secure boot: guarantees software authenticity and integrity • Secure update: secure delivery of the correct FW to the module • Anticlone detection and rejection: system automatically identifies and blocks clones that use the same RoT
Data security	<p>Secure libraries allow generation of hardware-backed crypto functions and keys for local encryption to secure local file storage and for end-to-end encryption.</p> <p>Data security features include:</p> <ul style="list-style-type: none"> • Local data protection: symmetric crypto functions via AT command to locally encrypt / decrypt and authenticate data (e.g. certificates, tokens) on the device. Allows also secure local storage of sensitive information in a non-secure location (e.g. in "standard" device memory) • Local chip-to-chip (C2C) security: unique cryptographic pairing between the MCU of the device and u-blox module by providing confidentiality, integrity, mutual authentication for their communication channel (e.g. UART interface) • E2E symmetric KMS: highly scalable method to provision and manage a session unique PSK available in cloud via REST API. Up to 8 times reduction in secure communication data overhead reducing data power consumption and cost E2E data protection: encrypt data on a device and decrypt asynchronously in cloud independent of protocols, servers, platforms or time before reaching final destination •
Access management	<p>Allow only authenticated access to device and features, safely manage changes of device ownership and provide out-of-the-box, simple, secure and cost effective zero touch onboarding to popular IoT cloud platforms.</p> <p>Access management features include:</p> <ul style="list-style-type: none"> • Change of ownership: efficient way to change the ownership and to apply the policies / authorizations of the new owner, even if the device is already in the field • Zero touch provisioning for AWS and Azure: out-of-the-box, simple, secure and cost effective AWS and Azure onboarding
Integrated GNSS receiver ³	<p>SARA-R510M8S modules are pre-integrated with a u-blox UBX-M8030 concurrent GNSS chipset with SPG 3.01 firmware version, comprehensive of a dedicated GNSS antenna interface, additional LNA and SAW filter for a highly reliable, accurate positioning data.</p> <p>The GNSS system is totally independent from the LTE system and can run concurrently to a LTE communication.</p>
External GNSS control via modem ⁴	<p>Full access to external u-blox positioning chips and modules through DDC (I2C) interface. This means that any host processor can control the SARA-R500S or SARA-R510S cellular module and the u-blox positioning chip or module through a single serial port.</p>

³ Not supported by SARA-R500S / SARA-R510S modules.

⁴ Not supported by SARA-R510M8S modules.

Feature	Description
Embedded AssistNow Software	Embedded AssistNow Online and AssistNow Offline clients are available to provide better GNSS performance and faster Time-to-First-Fix. An AT command can enable / disable the clients.
CellLocate®	Enables the estimation of device position based on the parameters of the mobile network cells visible to the specific device based on the CellLocate® database. CellLocate® is available via a set of AT commands for CellLocate® service configuration and position request.
Hybrid Positioning	Provides the module's current position using a u-blox positioning chip or module (external for SARA-R500S / SARA-R510S, integrated UBX-M8 chip for SARA-R510M8S) or the estimated position from CellLocate®, depending on which positioning method provides the best and fastest solution according to the user configuration. Hybrid positioning is implemented through a set of AT commands that allow the configuration and the position request.
CellTime™	Returns accurate timing retrieved from the LTE network and/or from the u-blox positioning chip or module (external for SARA-R500S / SARA-R510S, integrated UBX-M8 chip for SARA-R510M8S). Can be used to provide periodic time-stamps to an external application processor or to output a time indication associated to an interrupt detected on a GPIO (e.g. coming from an external sensor connected to the module). The implementation of CellTime™ can be extended to control and maintain timing info in a network of sensors (each one integrating a SARA-R5 module).
Antenna dynamic tuning	Control via two GPIOs an external antenna matching IC according to the LTE band used by the module.
Embedded TCP and UDP stack	Embedded TCP/IP and UDP/IP stack including direct link mode for TCP and UDP sockets. Sockets can be set in Direct Link mode to establish a transparent end-to-end communication with an already connected TCP or UDP socket via the serial interface.
HTTP, HTTPS	Hyper-Text Transfer Protocol as well as Secure Hyper-Text Transfer Protocol (SSL encryption) functionalities are supported via AT commands.
FTP, FTPS	File Transfer Protocol as well as Secure File Transfer Protocol (SSL encryption of FTP control channel) functionalities are supported by means of AT commands.
CoAP	Embedded Constrained Application Protocol (CoAP) datagram-based client/server application protocol designed to easily translate from HTTP for simplified integration with the web.
MQTT and MQTT-SN	Embedded Message Queuing Telemetry Transport (MQTT) and MQTT for Sensor Networks (MQTT-SN) publish-subscribe messaging protocols designed for lightweight M2M communications over TCP (MQTT) or over UDP (MQTT-SN). These allow one-to-one, one-to-many and many-to-one communications over a TCP or UDP connection.
LwM2M with dynamically loaded objects	The LwM2M is a light and compact communication protocol designed for managing IoT machine-to-machine communication between a LwM2M Server and a LwM2M Client located in lightweight, low power or resource-constrained LwM2M devices, with object data model. SARA-R5 series modules allow customers to configure dynamically loaded run time objects, defining necessary custom objects, creating instances of those objects as appropriate, managing module LwM2M protocol stack to interact with the LwM2M server.
TLS and DTLS	Transport Layer Security (TLS) version 1.2 provides security for HTTP, FTP, MQTT and TCP communications. Embedded Datagram Transport Layer Security (DTLS) version 1.2 provides security for CoAP, LwM2M, MQTT-SN and UDP communications.
Jamming detection	Detects "artificial" interference that obscures the operator's carrier entitled to give access to the radio service and automatically reports the start and stop of such conditions to the application processor that can react accordingly.
Last gasp	In case of power supply outage (i.e. main supply interruption, battery removal, battery voltage below a certain threshold) the cellular module can be configured to send an alarm notification to a remote entity. The feature can be enabled and configured through the +ULGASP AT command.
Network status indication	GPIO configured to indicate the network status: registered home network, registered roaming, data call enabled, no service. The feature can be enabled through the +UGPIOC AT command.

Feature	Description
Antenna detection	The ANT_DET pin provides antenna presence detection capability, evaluating the resistance from the ANT pin to GND by means of an external antenna detection circuit implemented on the application board. The antenna supervisor (i.e. antenna detection) feature can be enabled through the +UANTR AT command.
BIP	Bearer Independent Protocol for over-the-air SIM provisioning.
Dual stack IPv4/IPv6	Capability to move between IPv4 and dual stack network infrastructures. IPv4 and IPv6 addresses can be used.
Firmware update Over AT commands (FOAT)	Firmware module update over AT command interface. The feature can be enabled and configured through the +UFWUPD AT command.
u-blox Firmware update Over The Air (uFOTA)	u-blox firmware module update over the LTE air interface client/server solution using LwM2M.
Power Saving Mode (PSM)	The Power Saving Mode (PSM) feature, defined in 3GPP Rel.13, allows further reduction of the module current consumption maximizing the amount of time a device can remain in PSM low power deep-sleep mode during periods of data inactivity. It can be activated and configured by the +CPSMS AT command.
eDRX	Extended mode DRX, based on 3GPP Rel.13, reduces the amount of signaling overhead decreasing the frequency of scheduled measurements and/or transmissions performed by the module in idle mode. This in turn leads to a reduction in the module power consumption while maintaining a perpetual connection with the base station.
Coverage Enhancement (mode A and mode B)	Coverage Enhancement modes introduced in 3GPP Rel.13 are used to improve the cell signal penetration.
LTE-M and NB-IoT 3GPP release 14 features	For LTE-M: Larger max UL TBS (2984 bits instead of 1000 bits), Enhanced PUCCH repetition in CE mode B (64 and 128 repetition factor) For NB-IoT: Cat-NB2 higher data rate (with 2536 bit TBS), Release assistance indication, Power class 6 (maximum transmit power of 14 dBm) configurable by dedicated AT command, RRC connection re-establishment for the control plane CIoT EPS optimization, 2 UL/DL HARQ processes, Non-anchor paging and RACH, E-CID positioning

Table 3: Some of the main features supported by SARA-R5 series modules



The “00” products version of the SARA-R5 series modules do not support LTE NB-IoT.

2 Interfaces

2.1 Power management

2.1.1 Module supply input (VCC)

SARA-R5 series modules must be supplied through the **VCC** pins by a proper external DC power supply providing a nominal voltage within the normal operating range (see [Table 9](#)). Voltage must be stable, because during operation the current drawn from **VCC** may vary significantly, based on the power consumption profile of the LTE Cat M1 and LTE Cat NB2 radio access technologies (described in the SARA-R5 series system integration manual [\[2\]](#)).

The three **VCC** pins of SARA-R5 series modules are internally connected to both the internal Power Amplifier and the internal Power Management Unit, which integrates voltage regulators generating all the internal supply voltages needed by the module for the designed operations, as the supply voltage for the generic digital interfaces (**V_INT**), the supply voltage for the SIM interface (**VSIM**), and the supply voltage for the internal GNSS receiver.

It is important that the system power supply circuit is able to withstand the maximum pulse current during a transmit burst at maximum power level (see [Table 11](#)).

2.1.2 Generic digital interfaces supply output (V_INT)

SARA-R5 series modules provide a 1.8 V supply rail output on the **V_INT** pin, which is internally generated when the module is switched on. The same voltage domain is used internally to supply the generic digital interfaces of the module. The **V_INT** supply output can be used in place of an external discrete regulator.

 It is recommended to provide accessible test point directly connected to the **V_INT** pin.

2.2 Antenna interface

2.2.1 Cellular antenna RF interface (ANT)

The **ANT** pin is the cellular RF antenna I/O interface, designed with 50 Ω characteristic impedance.

2.2.2 GNSS antenna RF interface (ANT_GNSS)

 The GNSS antenna RF interface is not supported by SARA-R500S and SARA-R510S modules.

The **ANT_GNSS** pin represents the GNSS RF input of the SARA-R510M8S modules, designed with 50 Ω characteristic impedance and with an internal DC block, suitable for both active and/or passive GNSS antennas due to the built-in SAW filter followed by an LNA in front of the integrated high performing u-blox M8 concurrent positioning engine.

2.2.3 Antenna detection (ANT_DET)

The **ANT_DET** pin is an Analog to Digital Converter (ADC) input with a current source provided by SARA-R5 series modules to sense the external antenna presence (as an optional feature), evaluating the DC resistance to GND by means of an externally implemented circuit (for more details, see the u-blox SARA-R5 series system integration manual [\[2\]](#) and the SARA-R5 series AT commands manual [\[1\]](#)).

2.3 System functions

2.3.1 Module power-on

When the SARA-R500S and SARA-R510M8S modules are not powered, they can be switched on as following:

- Applying a voltage at the **VCC** module supply input within the operating range (see [Table 9](#))

When the SARA-R510S modules are not powered, they can be switched on as following:

- Applying a voltage at the **VCC** module supply input within the operating range (see [Table 9](#)), and then forcing a low level at the **PWR_ON** input pin, which is normally set high by an internal pull-up, for a valid time period (see section [4.2.6](#), module switch on).

When the SARA-R5 series modules are in power-off mode (i.e. switched off, but with a valid voltage present at the **VCC** module supply input within the operating range reported in [Table 9](#)), they can be switched on as following:

- Forcing a low level at the **PWR_ON** input pin, which is normally set high by an internal pull-up, for a valid time period (see section [4.2.6](#), module switch on).

When the SARA-R5 series modules are in low power PSM deep-sleep mode, with a valid voltage present at the **VCC** module supply input within the operating range reported in [Table 9](#), they can be woken up as following:

- Forcing a low level at the **PWR_ON** input pin, which is normally set high by an internal pull-up, for a valid time period (see section [4.2.6](#), module wake-up from PSM deep-sleep).

The **PWR_ON** line is intended to be driven by open drain, open collector or contact switch.

 It is recommended to provide accessible test point directly connected to the **PWR_ON** input pin.

2.3.2 Module power-off

SARA-R5 series can be properly switched off, saving current parameter settings in the module's non-volatile memory and performing a proper network detach, by:

- AT+CPWROFF command (see the SARA-R5 series AT commands manual [\[1\]](#))
- Forcing a low pulse at the **PWR_ON** input pin, for a valid time period (see section [4.2.6](#), module normal graceful switch-off)

A fast emergency shutdown procedure of the modules, without storage of the current parameter settings in the module's non-volatile memory and without proper network detach, can be triggered by

- Toggling the GPIO input pin configured with fast emergency shutdown function (see section [2.7](#), module fast emergency shutdown)

An abrupt under-voltage shutdown occurs on SARA-R5 series modules when the **VCC** supply is removed. If this occurs, it is not possible to store the current parameter settings in the module's non-volatile memory or to perform the proper network detach.

An over-temperature or an under-temperature shutdown occurs on the SARA-R5 series modules when the temperature measured within the module reaches the dangerous area, if the optional Smart Temperature Supervisor feature is enabled and configured by the dedicated AT command. For more details, see the SARA-R5 series system integration manual [\[2\]](#) and the SARA-R5 series AT commands manual [\[1\]](#).

2.3.3 Module reset

SARA-R5 series modules can be reset (re-booted), saving current parameter settings in the module's non-volatile memory and performing a proper network detach, by:

- AT+CFUN command (see the SARA-R5 series AT commands manual [1]). This causes a graceful software reset of the module.

An abrupt software reset of the module is executed by applying a low pulse at the **RESET_N** input pin, which is normally set high by an internal pull-up, for a valid time period (see section 4.2.7). The current parameter settings are not saved in the module's non-volatile memory and a proper network detach is not performed.

The **RESET_N** line is intended to be driven by open drain, open collector or contact switch.

 It is recommended to provide accessible test point directly connected to the **RESET_N** input pin.

An abrupt emergency hardware reset of the modules, without storage of the current parameter settings in the module's non-volatile memory and without proper network detach procedure, can be triggered by:

- Forcing a low pulse at the **PWR_ON** input pin, for a valid time period (see section 4.2.6, module abrupt emergency hardware reset)

2.4 SIM

2.4.1 SIM interface

SARA-R5 series modules provide on the **VSIM**, **SIM_IO**, **SIM_CLK**, **SIM_RST** pins an interface to connect an external SIM card/chip. Both 1.8 V and 3.0 V SIM types are supported. Activation and deactivation with an automatic voltage switch from 1.8 V to 3.0 V is implemented according to the ISO-IEC 7816-3 specifications.

2.4.2 SIM detection

The **GPIO5** pin of SARA-R5 series modules is a 1.8 V digital input which can be configured as an external interrupt to detect the SIM card presence (as a feature which can be optionally used), as intended to be properly connected to the mechanical switch of an external SIM card holder.

For more details, see the SARA-R5 series system integration manual [2] and the SARA-R5 series AT commands manual [1].

2.5 Serial communication

The SARA-R5 series provides the following serial communication interfaces:

- UART interfaces, available for communications with host application processor (2.5.1)
- USB 2.0 compliant interface, available for diagnostics only (2.5.2)
- SPI interfaces, available for communications with external SPI devices and for diagnostic (2.5.3)
- SDIO interface, available for communications with external SDIO devices (2.5.4)
- DDC (I2C bus compatible) interface, available for communications with external I2C devices (2.5.5)

2.5.1 UART interfaces

The SARA-R5 series modules include 1.8 V unbalanced asynchronous serial interfaces (UART) for communication with external application host processor(s).

UART can be configured by dedicated AT command in the following variants:

- **Variant 0** (default configuration), consists of a single UART interface that supports AT commands, data communication, multiplexer protocol functionality, FW update by means of FOAT or by means of the u-blox EasyFlash tool, and provides the following lines:
 - data lines (**RXD** as output, **TXD** as input),
 - hardware flow control lines (**CTS** as output, **RTS** as input),
 - modem status and control lines (**DTR** as input, **RI** as output)
- **Variant 1**, consists of a single UART interface that supports AT commands, data communication, multiplexer protocol functionality, FW update by means of FOAT or by means of the u-blox EasyFlash tool, and provides the following lines:
 - data lines (**RXD** as output, **TXD** as input),
 - hardware flow control lines (**CTS** as output, **RTS** as input),
 - modem status and control lines (**DTR** as input, **DSR** as output, **DCD** as output, **RI** as output)
- **Variants 2, 3 and 4**, consists of two UART interfaces plus ring indicator function:
 - First primary UART interface supports AT commands, data communication, multiplexer protocol functionality, FW update by means of FOAT or by means of the u-blox EasyFlash tool, and provides the following lines:
 - data lines (**RXD** as output, **TXD** as input),
 - hardware flow control lines (**CTS** as output, **RTS** as input),
 - Second auxiliary UART interface supports AT commands (variant 2 only), data communication (variant 2 only), FW update by means of FOAT (variant 2 only), diagnostic trace logging (variant 3 only), and GNSS tunneling (variant 4 only), and provides the following lines:
 - data lines (**DCD** as data output, **DTR** as data input),
 - hardware flow control lines (**RI** as flow control output, **DSR** as flow control input),
 - Ring indicator function over the GPIO pin configured with RI function (see section 2.7)

UART general features, valid for all variants, are:

- Serial port with RS-232 functionality conforming to the ITU-T V.24 recommendation [8], with CMOS compatible levels (0 V for low data bit or ON state, and 1.8 V for high data bit or OFF state)
- Hardware flow control (default value) or none flow control are supported
- UART power saving indication available on the hardware flow control output, if hardware flow control is enabled: the line is driven to the OFF state when the module is not prepared to accept data by the UART interface
- One-shot autobauding is supported and it is enabled by default: automatic baud rate detection is performed only once, at module start up. After the detection, the module works at the fixed baud rate (the detected one) and the baud rate can only be changed via AT command (see SARA-R5 series AT commands manual [1])
- Following baud rates are supported or can be detected by the one-shot autobauding: 9'600 bit/s, 19'200 bit/s, 38'400 bit/s, 57'600 bit/s, 115'200 bit/s, 230'400 bit/s, 460'800 bit/s, 921'600 bit/s
- The default frame format is 8N1 (8 data bits, no parity, 1 stop bit)

The UART interfaces can be conveniently configured through AT commands. For more details, see the SARA-R5 series AT commands manual [1] and SARA-R5 series system integration manual [2].

 It is highly recommended to provide accessible test points directly connected to the **TXD** and **RXD** pins for FW upgrade purpose.

 Accessible test points directly connected to the **DCD** and **DTR** pins may be provided for diagnostic purpose, alternatively to the highly recommended test points on the USB interface pins.

2.5.1.1 Multiplexer protocol

SARA-R5 series modules include multiplexer functionality as per 3GPP TS 27.010 [6] on the UART interfaces physical link. This is a data link protocol which uses HDLC-like framing and operates between the module (DCE) and the application processor (DTE), allowing a number of simultaneous sessions over the physical link (UART).

When USIO variant 0 or 1 is set, the following virtual channels are defined:

- Channel 0: control channel
- Channel 1 – 3: AT commands / data communication
- Channel 4: GNSS tunneling

When USIO variant 2 is set, AT commands and data communication are available on the second auxiliary UART, and the following virtual channels are defined on the primary UART:

- Channel 0: control channel
- Channel 1 – 2: AT commands / data communication
- Channel 3: GNSS tunneling

When USIO variant 3 is set, diagnostic trace log is available on the second auxiliary UART, and the following virtual channels are defined on the primary UART:

- Channel 0: control channel
- Channel 1 – 3: AT commands / data communication
- Channel 4: GNSS tunneling

When USIO variant 4 is set, GNSS tunneling is available on the second auxiliary UART, and the following virtual channels are defined on the primary UART:

- Channel 0: control channel
- Channel 1 – 3: AT commands / data communication

2.5.2 USB interface

SARA-R5 series modules include a high-speed USB 2.0 compliant interface with a maximum 480 Mbit/s data rate according to the USB 2.0 specification [9]. The module itself acts as a USB device and can be connected to any USB host equipped with compatible drivers.

The USB interface is available for diagnostic purpose only.

The **USB_D+** / **USB_D-** lines carry the USB data and signaling, while the **VUSB_DET** pin represents the input to enable the USB interface by applying an external valid USB VBUS voltage (5.0 V typical).

 It is highly recommended to provide accessible test points directly connected to the USB interface pins (**VUSB_DET**, **USB_D+**, **USB_D-**) for diagnostic purpose.

2.5.3 SPI interfaces

 The SPI interfaces are not supported by the “00” products version of SARA-R5 series modules, except for diagnostic purpose.

SARA-R5 series modules include 1.8V Serial Peripheral Interfaces available for communications with external SPI slave devices, or with the module acting as SPI master, for diagnostic purpose.

2.5.4 SDIO interface

 The SDIO interface is not supported by the “00” products version of SARA-R5 series modules.

SARA-R5 series modules include a 1.8V 4-bit Secure Digital Input Output interface over the **SDIO_D0**, **SDIO_D1**, **SDIO_D2**, **SDIO_D3**, **SDIO_CLK** and **SDIO_CMD** pins, with the module acting as an SDIO host, available for communications with compatible external SDIO devices, and for diagnostic purpose.

 Accessible test points directly connected to the **SDIO_D0**, **SDIO_D1**, **SDIO_D2** and **SDIO_D3** pins may be provided for diagnostic purpose, alternatively to the highly recommended accessible test points provided on the USB interface pins.

2.5.5 DDC (I2C) interface

 Communication with an external GNSS receiver is not supported by SARA-R510M8S modules.

SARA-R5 series modules include a 1.8V I2C-bus compatible DDC interface over the **SDA** and **SCL** pins, available to communicate with an external u-blox GNSS receiver and with external I2C devices as for example an audio codec: the SARA-R5 series module acts as an I2C master that can communicate with I2C slaves in accordance with the I2C bus specifications [\[10\]](#).

 It is recommended to provide accessible test points directly connected to the **SDA** and **SCL** pins for diagnostic purpose.

2.6 Audio

 Audio is not supported by the “00” products version of SARA-R5 series modules.

SARA-R5 series modules include a 1.8V I2S digital audio interface over the **I2S_TXD**, **I2S_RXD**, **I2S_CLK** and **I2S_WA** pins, available to transfer digital audio data with an external digital audio device.

2.7 GPIO

SARA-R5 series modules include pins that can be configured as general purpose input/output or to provide custom functions as summarized in [Table 4](#). For further details, see the SARA-R5 series system integration manual [\[2\]](#) and the SARA-R5 series AT commands manual [\[1\]](#), +UGPIOC, +UGPIOR, +UGPIOW, +UTEST AT commands).

Function	Description	Default GPIO	Configurable GPIOs
General purpose output	Output to set high or low digital level	-	GPIO1, GPIO2, GPIO3, GPIO4, GPIO5, GPIO6
General purpose input	Input to sense high or low digital level	-	GPIO1, GPIO2, GPIO3, GPIO4, GPIO5, GPIO6
Network status indication	Output indicating cellular network status: registered, data transmission, no service	-	GPIO1, GPIO2, GPIO3, GPIO4, GPIO5, GPIO6
External GNSS supply enable ⁵	Output to enable/disable the supply of an external u-blox GNSS receiver connected to the cellular module by the DDC (I2C) interface	-	GPIO2 ⁵
External GNSS data ready ⁵	Input to sense when an external u-blox GNSS receiver connected to the module is ready for sending data over the DDC (I2C) interface	-	GPIO3 ⁵
SIM card detection	Input for SIM card physical presence detection, to optionally enable / disable SIM interface upon detection of external SIM card physical insertion / removal	-	GPIO5
Module status indication	Output indicating module status: power-off or deep-sleep mode versus idle, active or connected mode	-	GPIO1, GPIO2, GPIO3, GPIO4, GPIO5, GPIO6
Module operating mode indication	Output indicating module operating mode: power-off, deep-sleep or idle mode versus active or connected mode	-	GPIO1, GPIO2, GPIO3, GPIO4, GPIO5, GPIO6
Ring indicator	Output providing events indicator	-	GPIO1, GPIO2, GPIO3, GPIO4, GPIO5, GPIO6
Last gasp	Input to trigger last gasp notification	-	GPIO1, GPIO2, GPIO3, GPIO4, GPIO5, GPIO6
Time pulse output	Output providing accurate time reference, as a sequence with 1 PPS or as single time pulse, based on the GNSS system or the LTE system	-	GPIO6
Time stamp of external interrupt	Input triggering via interrupt the generation of an URC time stamp over AT serial interface	-	EXT_INT
Fast power-off	Input to trigger emergency fast and safe shutdown of the module (as triggered by AT+CFUN=10 command)	-	GPIO1, GPIO2, GPIO3, GPIO4, GPIO5, GPIO6
External GNSS time pulse ⁵	Input to receive an accurate time reference, as a sequence with 1 PPS from an external GNSS system	-	SDIO_CMD
External GNSS time stamp of external interrupt ⁵	Output triggering via interrupt the generation of an URC time stamp from an external GNSS system	-	GPIO4
Pin disabled	Tri-state with an internal active pull-down enabled	GPIO1, GPIO2, GPIO3, GPIO4, GPIO5, GPIO6, EXT_INT, SDIO_CMD	GPIO1, GPIO2, GPIO3, GPIO4, GPIO5, GPIO6, EXT_INT, SDIO_CMD
Antenna dynamic tuning	Output for real time control of an antenna tuning IC according to the LTE band used by the module	-	I2S_TXD, I2S_WA

Table 4: GPIO custom functions configuration

⁵ SARA-R500S and SARA-R510S modules only.

3 Pin definition

3.1 Pin assignment

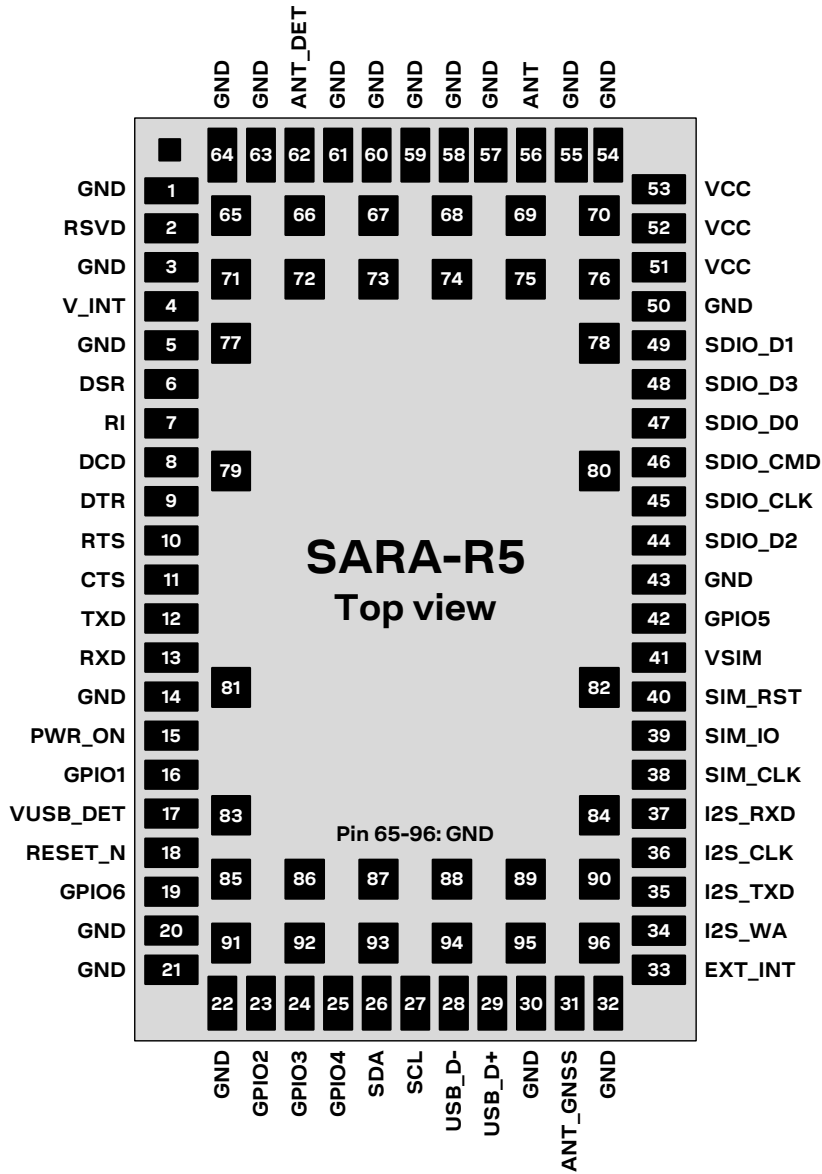

Figure 4: SARA-R5 series modules pin assignment (top view)

No	Name	Power domain	I/O	Description	Remarks
1	GND	-	N/A	Ground	All the GND pins must be connected to ground.
2	RSVD	-	N/A	Reserved pin	Leave unconnected.
3	GND	-	N/A	Ground	All the GND pins must be connected to ground.
4	V_INT	-	O	Generic Digital Interfaces supply output	V_INT generated by the module when is switched on. See section 2.1.2 for functional description. See section 4.2.2 for detailed electrical specs. Provide test point for diagnostic purposes.
5	GND	-	N/A	Ground	All the GND pins must be connected to ground.
6	DSR	GDI	O	UART data set ready / AUX UART request to send	Circuit 107 (DSR) in ITU-T V.24, alternatively configurable as Second Auxiliary UART RTS (with internal active pull-up enabled). See section 2.5.1 and 2.5.3 for functional description. See section 4.2.9 for detailed electrical specs.
7	RI	GDI	O	UART ring indicator / AUX UART clear to send	Circuit 125 (RI) in ITU-T V.24, alternatively configurable as Second Auxiliary UART CTS. See section 2.5.1 and 2.5.3 for functional description. See section 4.2.9 for detailed electrical specs.
8	DCD	GDI	O	UART data carrier detect / AUX UART data output	Circuit 109 (DCD) in ITU-T V.24, alternatively settable as Second Auxiliary UART RXD. See section 2.5.1 and 2.5.3 for functional description. See section 4.2.9 for detailed electrical specs.
9	DTR	GDI	I	UART data terminal ready / AUX UART data input	Circuit 108/2 (DTR) in ITU-T V. 24, alternatively settable as Second Auxiliary UART TXD (with internal active pull-up enabled). Internal active pull-up enabled. See section 2.5.1 and 2.5.3 for functional description. See section 4.2.9 for detailed electrical specs.
10	RTS	GDI	I	UART request to send	Circuit 105 (RTS) in ITU-T V.24. Internal active pull-up enabled. See section 2.5.1 for functional description. See section 4.2.9 for detailed electrical specs.
11	CTS	GDI	O	UART clear to send	Circuit 106 (CTS) in ITU-T V.24. See section 2.5.1 for functional description. See section 4.2.9 for detailed electrical specs.
12	TXD	GDI	I	UART data input	Circuit 103 (TxD) in ITU-T V.24. Internal active pull-up enabled. See section 2.5.1 for functional description. See section 4.2.9 for detailed electrical specs. Provide test point for FW update purposes.
13	RXD	GDI	O	UART data output	Circuit 104 (RxD) in ITU-T V.24. See section 2.5.1 for functional description. See section 4.2.9 for detailed electrical specs. Provide test point for FW update purposes.
14	GND	-	N/A	Ground	All the GND pins must be connected to ground.
15	PWR_ON	POS	I	Power-on / power-off input	Internal active pull-up. See section 2.3.1 and 2.3.2 for functional description. See section 4.2.6 for detailed electrical specs. Provide test point for diagnostic purposes.
16	GPIO1	GDI	I/O	GPIO	Configurable GPIO. See section 2.7 for functional description. See section 4.2.9 for detailed electrical specs.

No	Name	Power domain	I/O	Description	Remarks
17	VUSB_DET	USB	I	USB detect input	Input for VBUS (5 V typical) USB supply sense. USB interface supported for diagnostic purpose only. See section 2.5.2 for functional description. See section 4.2.11 for detailed electrical specs. Provide test point for diagnostic purposes.
18	RESET_N	GDI	I	External reset input	Internal active pull-up. See section 2.3.3 for functional description. See section 4.2.7 for detailed electrical specs. Provide test point for diagnostic purposes.
19	GPIO6	GDI	I/O	GPIO / Time pulse output	Configurable GPIO, alternatively configurable as output providing accurate time reference. See section 2.7 for functional description. See section 4.2.9 for detailed electrical specs.
20	GND	-	N/A	Ground	All the GND pins must be connected to ground.
21	GND	-	N/A	Ground	All the GND pins must be connected to ground.
22	GND	-	N/A	Ground	All the GND pins must be connected to ground.
23	GPIO2	GDI	I/O	GPIO	Configurable GPIO. See section 2.7 for functional description. See section 4.2.9 for detailed electrical specs.
24	GPIO3	GDI	I/O	GPIO	Configurable GPIO. See section 2.7 for functional description. See section 4.2.9 for detailed electrical specs.
25	GPIO4	GDI	I/O	GPIO / External GNSS time stamp of external interrupt ⁶	Configurable GPIO, alternatively configurable as output indicating the generation of an URC time stamp. See section 2.7 for functional description. See section 4.2.9 for detailed electrical specs.
26	SDA	DDC	I/O	I2C bus data line	Fixed open drain. Internal active pull-up. See section 2.5.5 for functional description. See section 4.2.10 for detailed electrical specs. Provide test point for diagnostic purposes.
27	SCL	DDC	O	I2C bus clock line	Fixed open drain. Internal active pull-up. See section 2.5.5 for functional description. See section 4.2.10 for detailed electrical specs. Provide test point for diagnostic purposes.
28	USB_D-	USB	I/O	USB Data Line D-	90 Ω nominal differential impedance. Pull-up, pull-down and series resistors, as required by the USB 2.0 specifications [9], are part of the USB pin driver and shall not be provided externally. USB interface supported for diagnostic purpose only. See section 2.5.2 for functional description. See section 4.2.11 for detailed electrical specs. Provide test point for diagnostic purposes.
29	USB_D+	USB	I/O	USB Data Line D+	90 Ω nominal differential impedance. Pull-up, pull-down and series resistors, as required by USB 2.0 specifications [9], are part of the USB pin driver and shall not be provided externally. USB interface supported for diagnostic purpose only. See section 2.5.2 for functional description. See section 4.2.11 for detailed electrical specs. Provide test point for diagnostic purposes.

⁶ Not supported by SARA-R510M8S modules

No	Name	Power domain	I/O	Description	Remarks
30	GND	-	N/A	Ground	All the GND pins must be connected to ground.
31	ANT_GNSS	-	I	GNSS antenna ⁷	RF input for GNSS Rx antenna. 50 Ω nominal impedance. See section 2.2.2 and Table 2 for functional description.
32	GND	-	N/A	Ground	All the GND pins must be connected to ground.
33	EXT_INT	GDI	I	External interrupt	Configurable as interrupt input triggering the generation of an URC time stamp. See section 2.7 for functional description. See section 4.2.9 for detailed electrical specs.
34	I2S_WA	GDI	O	I2S word alignment / Pin for antenna dynamic tuning	I2S not supported by “00” products version. Configurable as pin for antenna dynamic tuning. See section 2.7 for functional description. See section 4.2.9 for detailed electrical specs.
35	I2S_TXD	GDI	O	I2S transmit data / Pin for antenna dynamic tuning	I2S not supported by “00” products version. Configurable as pin for antenna dynamic tuning. See section 2.7 for functional description. See section 4.2.9 for detailed electrical specs.
36	I2S_CLK	GDI	O	I2S clock	I2S not supported by “00” products version.
37	I2S_RXD	GDI	I	I2S receive data	I2S not supported by “00” products version.
38	SIM_CLK	SIM	O	SIM clock	See section 2.4.1 for functional description. See section 4.2.8 for detailed electrical specs.
39	SIM_IO	SIM	I/O	SIM data	See section 2.4.1 for functional description. See section 4.2.8 for detailed electrical specs.
40	SIM_RST	SIM	O	SIM reset	See section 2.4.1 for functional description. See section 4.2.8 for detailed electrical specs.
41	VSIM	-	O	SIM supply output	See section 2.4.1 for functional description. See section 4.2.8 for detailed electrical specs.
42	GPIO5	GDI	I/O	GPIO / SIM card detection	Configurable GPIO, alternatively configurable as pin for SIM card detection. See sections 2.4.2 and 2.7 for functional description. See section 4.2.9 for detailed electrical specs.
43	GND	-	N/A	Ground	All the GND pins must be connected to ground.
44	SDIO_D2	GDI	I/O	SDIO serial data [2] / SPI_CLK	SDIO not supported by “00” products version. The pin is alternatively configurable as SPI_CLK, for diagnostic purpose only.
45	SDIO_CLK	GDI	O	SDIO serial clock	SDIO not supported by “00” products version.
46	SDIO_CMD	GDI	I/O	SDIO command / External GNSS time pulse input ⁸	SDIO not supported by “00” products version. Configurable as input for external GNSS time pulse. See section 2.7 for functional description. See section 4.2.9 for detailed electrical specs.
47	SDIO_D0	GDI	I/O	SDIO serial data [0] / SPI_MOSI	SDIO not supported by “00” products version. The pin is alternatively configurable as SPI_MOSI, for diagnostic purpose only.
48	SDIO_D3	GDI	I/O	SDIO serial data [3] / SPI_CS	SDIO not supported by “00” products version. The pin is alternatively configurable as SPI_CS, for diagnostic purpose only.
49	SDIO_D1	GDI	I/O	SDIO serial data [1] / SPI_MISO	SDIO not supported by “00” products version. The pin is alternatively configurable as SPI_MISO, for diagnostic purpose only.

⁷ Not supported by SARA-R500S and SARA-R510S modules

⁸ Not supported by SARA-R510M8S modules

No	Name	Power domain	I/O	Description	Remarks
50	GND	-	N/A	Ground	All the GND pins must be connected to ground.
51	VCC	-	I	Module supply input	All VCC pins must be connected to external supply. See section 2.1.1 for functional description. See section 4.2.2 for detailed electrical specs.
52	VCC	-	I	Module supply input	All VCC pins must be connected to external supply. See section 2.1.1 for functional description. See section 4.2.2 for detailed electrical specs.
53	VCC	-	I	Module supply input	All VCC pins must be connected to external supply. See section 2.1.1 for functional description. See section 4.2.2 for detailed electrical specs.
54	GND	-	N/A	Ground	All the GND pins must be connected to ground.
55	GND	-	N/A	Ground	All the GND pins must be connected to ground.
56	ANT	-	I/O	Cellular antenna	RF input/output for Cellular Rx/Tx antenna. 50 Ω nominal impedance. See section 2.2.1 and 4.2.5 for details.
57	GND	-	N/A	Ground	All the GND pins must be connected to ground.
58	GND	-	N/A	Ground	All the GND pins must be connected to ground.
59	GND	-	N/A	Ground	All the GND pins must be connected to ground.
60	GND	-	N/A	Ground	All the GND pins must be connected to ground.
61	GND	-	N/A	Ground	All the GND pins must be connected to ground.
62	ANT_DET	ADC	I	Antenna detection	Antenna presence detection function. See section 2.2.3 for details.
63	GND	-	N/A	Ground	All the GND pins must be connected to ground.
64	GND	-	N/A	Ground	All the GND pins must be connected to ground.
65-96	GND	-	N/A	Ground	All the GND pins must be connected to ground.

Table 5: SARA-R5 series pin-out

 For more information about the pin-out, see the u-blox SARA-R5 series system integration manual [2].

 See Appendix A for an explanation of the abbreviations and terms used.

4 Electrical specifications

- Stressing the device above one or more of the ratings listed in the Absolute Maximum Rating section may cause permanent damage. These are stress ratings only. Operating the module at these or at any conditions other than those specified in the Operating Conditions sections (section 4.2) of the specification should be avoided. Exposure to Absolute Maximum Rating conditions for extended periods may affect device reliability.
- Operating condition ranges define those limits within which the functionality of the device is guaranteed.
- Electrical characteristics are defined according to the verification on a representative number of samples or according to the simulation.
- Where application information is given, it is advisory only and does not form part of the specification.

4.1 Absolute maximum rating

Limiting values given below are in accordance with Absolute Maximum Rating System (IEC 134).

Symbol	Description	Condition	Min.	Max.	Unit
VCC	Module supply voltage	Input DC voltage at VCC pins	-0.3	4.6	V
VUSB_DET	USB detection pin	Input DC voltage at VUSB_DET pin	-0.3	5.5	V
USB	USB D+/D- pins	Input DC voltage at USB interface pins	-0.3	3.6	V
GDI	Generic digital interfaces	Input DC voltage at Generic digital interfaces pins	-0.3	2.3	V
DDC	DDC interface	Input DC voltage at DDC interface pins	-0.3	2.3	V
SIM	SIM interface	Input DC voltage at SIM interface pins	-0.3	3.5	V
POS	Power-on input	Input DC voltage at PWR_ON pin	-0.3	2.3	V
ADC	Antenna detection input	Input DC voltage at ANT_DET pin	-0.3	2.3	V
P_RF	RF power	Input RF power at ANT pin		3	dBm
		Input RF power at ANT_GNSS pin		0	dBm
Rho_ANT	Antenna ruggedness	Output RF load mismatch ruggedness at ANT pins		10:1	VSWR
Tstg	Storage temperature		-40	+85	°C

Table 6: Absolute maximum ratings

- The product is not protected against overvoltage or reversed voltages. If necessary, voltage spikes exceeding the voltage specifications given in the table above, must be limited to values within the specified boundaries by using appropriate protection devices.

4.1.1 Maximum ESD

Parameter	Min	Typical	Max	Unit	Remarks
ESD sensitivity for all pins			1000	V	Human Body Model according to JESD22-A114

Table 7: Maximum ESD ratings

- u-blox cellular modules are electrostatic sensitive devices and require special precautions when handling. See section 7.3 for ESD handling instructions.

4.2 Operating conditions

Unless otherwise indicated, all operating condition specifications are at an ambient temperature of +25 °C.

Operation beyond the operating conditions is not recommended and extended exposure beyond them may affect device reliability.

4.2.1 Operating temperature range

Parameter	Min.	Typ.	Max.	Unit	Remarks
Normal operating temperature	-20	+25	+65	°C	Normal operating temperature range (fully functional and meet 3GPP / ETSI specifications)
Extended operating temperature	-40		+85	°C	Extended operating temperature range (RF performance may be affected outside normal operating range, though module is fully functional)

Table 8: Environmental conditions

4.2.2 Supply/power pins

Symbol	Parameter	Min.	Typical	Max.	Unit
VCC	Module supply normal operating input voltage ⁹	3.3	3.8	4.4	V
	Module supply extended operating input voltage ¹⁰	3.0		4.5	V

Table 9: Input characteristics of the Supply/Power pins

Symbol	Parameter	Min.	Typical	Max.	Unit
VSIM	SIM supply output voltage with 1.8 V external SIM		1.8		V
	SIM supply output voltage with 3.0 V external SIM		3.0		V
V_INT	Generic Digital Interfaces supply output voltage		1.8		V
I_INT	Generic Digital Interfaces supply output current capability			70	mA

Table 10: Output characteristics of the Supply/Power pins

⁹ Occasional deviations from 3GPP / ETSI specifications may occur if the VCC voltage is outside normal operating range limits.

¹⁰ The switch-on and general operations of the module are guaranteed only if the VCC voltage is within the extended operating range limits. Module may switch off when the VCC voltage drops below the extended operating range minimum limit.

¹¹ Typical values with matched antenna, VCC = 3.8 V

4.2.3 Current consumption

Mode	Condition	Tx power	Module	Min	Typ ¹¹	Max	Unit
Power-off mode	Average current value (power-off mode)	--	SARA-R510S		0.5		μA
			SARA-R500S		62		μA
			SARA-R510M8S				
PSM deep-sleep mode	Average current value (PSM deep-sleep mode)	--	SARA-R510S		0.5		μA
			SARA-R500S		62		μA
			SARA-R510M8S				
Cyclic idle / active mode (+UPSV=1)	Average current value (rock bottom)	--	All		1.0		mA
	Average current value (DRX = 2.56 s, PTW = 20.48 s, eDRX = 655.36 s)	--	All		1.1		mA
	Average current value (DRX = 2.56 s, PTW = 20.48 s, eDRX = 81.92 s)	--	All		1.2		mA
	Average current value (DRX = 2.56 s, PTW = 5.12 s, eDRX = 20.48 s)	--	All		1.2		mA
	Average current value (DRX = 2.56 s, no eDRX)	--	All		1.5		mA
	Average current value (DRX = 1.28 s, no eDRX)	--	All		2.0		mA
	Average current value (DRX = 1.28 s)	--	All		25		mA
LTE Cat M1 connected mode	Average current value (Tx/ Rx data transfer)	Minimum (-50 dBm)	All		95		mA
			0 dBm	All		100	mA
			8 dBm	All		115	mA
			14 dBm	All		140	mA
			20 dBm	All		170	mA
			Maximum (23 dBm)	All		195	mA
	Maximum current value (During Tx only)	Maximum (23 dBm)	All		395		mA

Table 11: VCC current consumption of SARA-R5 series modules with GNSS off

¹¹ Typical values with matched antenna, VCC = 3.8 V

Mode / Condition	Min	Typ ¹²	Max	Unit
Average current value with power saving enabled (+UPSV=1), UBX-R5 in PSM, UBX-M8 in cyclic tracking mode with 1 s update period (GPS)		15		mA
Average current value with power saving enabled (+UPSV=1), UBX-R5 in PSM, UBX-M8 in cyclic tracking mode with 1 s update period (GPS & GLONASS)		16		mA
Average current value with power saving enabled (+UPSV=1), UBX-R5 in PSM, UBX-M8 in continuous tracking mode (GPS & GLONASS)		43		mA
Average current value with power saving enabled (+UPSV=1), UBX-R5 in DRX = 1.28 s, UBX-M8 in cyclic tracking mode with 1 s update period (GPS)		16		mA
Average current value with power saving enabled (+UPSV=1), UBX-R5 in DRX = 1.28 s, UBX-M8 in cyclic tracking mode with 1 s update period (GPS & GLONASS)		17		mA
Average current value with power saving enabled (+UPSV=1), UBX-R5 in DRX = 1.28 s, UBX-M8 in continuous tracking mode (GPS & GLONASS)		44		mA
Average current value with power saving disabled (+UPSV=0), UBX-R5 in DRX = 1.28 s, UBX-M8 in continuous tracking mode (GPS & GLONASS)		67		mA
Average current value with power saving disabled (+UPSV=0), UBX-R5 in DRX = 1.28 s, UBX-M8 in acquisition mode (GPS & GLONASS)		72		mA
Peak current value with power saving disabled (+UPSV=0), UBX-R5 in DRX = 1.28 s, UBX-M8 in acquisition mode (GPS & GLONASS)		100		mA

Table 12: Indicative VCC current consumption of the SARA-R510M8S module with GNSS on

4.2.4 GNSS characteristics

Parameter	Condition	Value				
Receiver type		72-channel u-blox M8 engine GPS L1C/A, SBAS L1C/A, QZSS L1C/A, QZSS L1-SAIF, GLONASS L1OF, BeiDou B1I, Galileo E1B/C				
Operational limits ¹³	Dynamics	≤ 4 g				
	Altitude	50'000 m				
	Velocity	500 m/s				
Velocity accuracy ¹⁴		0.05 m/s				
Heading accuracy ¹⁴		0.3 degrees				
GNSS		GPS & GLONASS	GPS	GLONASS	BeiDou	Galileo
Horizontal position accuracy ¹⁵		2.5 m	2.5 m	4 m	3 m	3 m
Max navigation update rate		10 Hz	18 Hz	18 Hz	18 Hz	18 Hz
Time-To-First-Fix ¹⁶	Cold start	26 s	29 s	30 s	34 s	45 s
	Aided starts ¹⁷	2 s	2 s	2 s	3 s	7 s
Sensitivity	Tracking & Navigation	-167 dBm	-166 dBm	-166 dBm	-160 dBm	-159 dBm
	Reacquisition	-160 dBm	-160 dBm	-156 dBm	-157 dBm	-153 dBm
	Cold start	-148 dBm	-148 dBm	-145 dBm	-143 dBm	-138 dBm

Table 13: GNSS characteristics and performance of the SARA-R510M8S module
¹² Typical values with matched antenna, VCC = 3.8 V

¹³ Assuming Airborne < 4 g platform

¹⁴ 50% @ 30 m/s

¹⁵ CEP, 50%, 24 hours static, -130 dBm, > 6 SVs

¹⁶ All satellites at -130 dBm, except Galileo at -127 dBm

¹⁷ Dependent on aiding data connection speed and latency¹⁸ Not supported in LTE category M1

4.2.5 LTE RF characteristics

The LTE Cat M1 / NB2 bands supported by SARA-R5 series modules are defined in [Table 2](#), while the following [Table 14](#) describes the frequency ranges for each LTE band as per 3GPP TS 36.521-1 [7].

Parameter		Min.	Max.	Unit	Remarks
Frequency range FDD band 71 (600 MHz) ¹⁸	Uplink	663	698	MHz	Module transmit
	Downlink	617	652	MHz	Module receive
Frequency range FDD band 12 (700 MHz)	Uplink	699	716	MHz	Module transmit
	Downlink	729	746	MHz	Module receive
Frequency range FDD band 28 (700 MHz)	Uplink	703	748	MHz	Module transmit
	Downlink	758	803	MHz	Module receive
Frequency range FDD band 85 (700 MHz) ¹⁸	Uplink	698	716	MHz	Module transmit
	Downlink	728	746	MHz	Module receive
Frequency range FDD band 13 (750 MHz)	Uplink	777	787	MHz	Module transmit
	Downlink	746	756	MHz	Module receive
Frequency range FDD band 20 (800 MHz)	Uplink	832	862	MHz	Module transmit
	Downlink	791	821	MHz	Module receive
Frequency range FDD band 26 (850 MHz)	Uplink	814	849	MHz	Module transmit
	Downlink	859	894	MHz	Module receive
Frequency range FDD band 18 (850 MHz)	Uplink	815	830	MHz	Module transmit
	Downlink	860	875	MHz	Module receive
Frequency range FDD band 5 (850 MHz)	Uplink	824	849	MHz	Module transmit
	Downlink	869	894	MHz	Module receive
Frequency range FDD band 19 (850 MHz)	Uplink	830	845	MHz	Module transmit
	Downlink	875	890	MHz	Module receive
Frequency range FDD band 8 (900 MHz)	Uplink	880	915	MHz	Module transmit
	Downlink	925	960	MHz	Module receive
Frequency range FDD band 4 (1700 MHz)	Uplink	1710	1755	MHz	Module transmit
	Downlink	2110	2155	MHz	Module receive
Frequency range FDD band 66 (1700 MHz) ¹⁸	Uplink	1710	1780	MHz	Module transmit
	Downlink	2110	2200	MHz	Module receive
Frequency range FDD band 3 (1800 MHz)	Uplink	1710	1785	MHz	Module transmit
	Downlink	1805	1880	MHz	Module receive
Frequency range FDD band 2 (1900 MHz)	Uplink	1850	1910	MHz	Module transmit
	Downlink	1930	1990	MHz	Module receive
Frequency range FDD band 25 (1900 MHz) ¹⁹	Uplink	1850	1915	MHz	Module transmit
	Downlink	1930	1995	MHz	Module receive
Frequency range FDD band 1 (2100 MHz)	Uplink	1920	1980	MHz	Module transmit
	Downlink	2110	2170	MHz	Module receive

Table 14: LTE operating RF frequency bands

SARA-R5 series modules include a UE Power Class 3 LTE Cat M1 / NB2 transmitter (see [Table 2](#)) and an LTE receiver, with output power and characteristics according to 3GPP TS 36.521-1 [7].



The “00” products version of the SARA-R5 series modules do not support LTE NB-IoT.

¹⁸ Not supported in LTE category M1

¹⁹ Not supported in LTE category NB2

SARA-R5 series modules LTE receiver characteristics are compliant to 3GPP TS 36.521-1 [7], with LTE conducted receiver sensitivity performance described in Table 15.

Parameter	Min.	Typical	Max.	Unit	Remarks
Receiver input sensitivity Band 12 (700 MHz)		-110.5		dBm	Without repetitions
Receiver input sensitivity Band 28 (700 MHz)		-110.5		dBm	Without repetitions
Receiver input sensitivity Band 13 (750 MHz)		-110.5		dBm	Without repetitions
Receiver input sensitivity Band 20 (800 MHz)		-110.5		dBm	Without repetitions
Receiver input sensitivity Band 26 (850 MHz)		-110.0		dBm	Without repetitions
Receiver input sensitivity Band 18 (850 MHz)		-110.0		dBm	Without repetitions
Receiver input sensitivity Band 5 (850 MHz)		-110.0		dBm	Without repetitions
Receiver input sensitivity Band 19 (850 MHz)		-110.0		dBm	Without repetitions
Receiver input sensitivity Band 8 (900 MHz)		-109.5		dBm	Without repetitions
Receiver input sensitivity Band 4 (1700 MHz)		-109.0		dBm	Without repetitions
Receiver input sensitivity Band 3 (1800 MHz)		-109.0		dBm	Without repetitions
Receiver input sensitivity Band 2 (1900 MHz)		-109.0		dBm	Without repetitions
Receiver input sensitivity Band 25 (1900 MHz)		-109.0		dBm	Without repetitions
Receiver input sensitivity Band 1 (2100 MHz)		-109.0		dBm	Without repetitions

Condition: 50 Ω source, throughput > 95%, QPSK modulation, other settings as per clause 7.3EA of 3GPP TS 36.521-1 [7]

Table 15: LTE Cat M1 receiver sensitivity performance

4.2.6 PWR_ON pin

Parameter	Min.	Typical	Max.	Unit	Remarks
Low-level input	-0.3		0.3	V	
Pull-up resistance		10		k Ω	Integrated pull-up to internal rail
Low-level input current		-300		μ A	
PWR_ON low time	1		2	s	Low time to trigger module switch on from power-off mode
	1		2	s	Low time to trigger module wake-up from PSM deep-sleep
	1.5		2.5	s	Low time to trigger module normal graceful switch off
	20			s	Low time to trigger module abrupt emergency hardware reset

Table 16: PWR_ON pin characteristics

4.2.7 RESET_N pin

Parameter	Min.	Typical	Max.	Unit	Remarks
Internal supply		1.8			Digital I/O Interfaces supply (V_INT)
Low-level input	-0.3		0.5	V	
Low-level input current	-18	-32	-56	μA	
RESET_N low time	100			ms	Low time to trigger module reset / reboot

Table 17: RESET_N pin characteristics

4.2.8 SIM pins

The SIM pins are a dedicated interface to the external SIM card/chip. The electrical characteristics fulfill the regulatory specification requirements. The values in [Table 18](#) are for information only.

Parameter	Min.	Typ.	Max.	Unit	Remarks
Internal supply domain for SIM interface		1.8		V	VSIM, with external 1.8 V SIM type
		3.0		V	VSIM, with external 3.0 V SIM type
Low-level input	-0.3		0.2*VSIM	V	
High-level input	0.6*VSIM		VSIM+0.3	V	
Low-level output		0.0		V	
High-level output		VSIM		V	
Internal pull-up resistor on SIM_IO		4.7		kΩ	Internal pull-up to VSIM supply

Table 18: SIM pin characteristics

4.2.9 Generic Digital Interfaces pins

Parameter	Min	Typical	Max	Unit	Remarks
Internal supply for GDI domain		1.8		V	Digital I/O Interfaces supply (V_INT)
Low-level input	-0.3		0.5	V	
High-level input	1.3		2.1	V	
Low-level output		0.0	0.4	V	
High-level output	1.4	1.8		V	
Input leakage current			1	μA	0 V < V _{IN} < 1.8 V
Output high driver strength	3.28	5.22	7.92	mA	V _{OUT} = 1.4
Output low driver strength	3.02	5.41	8.63	mA	V _{OUT} = 0.4
Pull-up input current	-18	-32	-56	μA	
Pull-down input current	15	30	56	μA	

Table 19: GDI pin characteristics

4.2.10 DDC (I2C) pins

DDC (I2C) lines (**SCL** and **SDA**) are compliant to the I2C-bus standard mode specification. See the I2C-bus specification [10] for detailed electrical characteristics.

Parameter	Min	Typical	Max	Unit	Remarks
Internal supply for DDC domain		1.8		V	Digital I/O Interfaces supply (V_INT)
Low-level input	-0.3		0.5	V	
High-level input	1.3		2.1	V	
Low-level output		0.0		V	
Pull-up input current		-450		μA	

Table 20: DDC (I2C) pin characteristics

4.2.11 USB pins

USB data lines (**USB_D+** / **USB_D-**) are compliant with the USB 2.0 high-speed specification. See the Universal Serial Bus specification revision 2.0 [9] for detailed electrical characteristics. The values in Table 21 related to USB 2.0 high-speed physical layer specifications are for information only.

Parameter	Min.	Typical	Max.	Unit	Remarks
VUSB_DET pin, High-level input	4.40	5.00	5.25	V	
High-speed squelch detection threshold (input differential signal amplitude)	100		150	mV	
High speed disconnect detection threshold (input differential signal amplitude)	525		625	mV	
High-speed data signaling input common mode voltage range	-50		500	mV	
High-speed idle output level	-10		10	mV	
High-speed data signaling output high level	360		440	mV	
High-speed data signaling output low level	-10		10	mV	
Chirp J level (output differential voltage)	700		1100	mV	
Chirp K level (output differential voltage)	-900		-500	mV	

Table 21: USB pins characteristics

5 Mechanical specifications

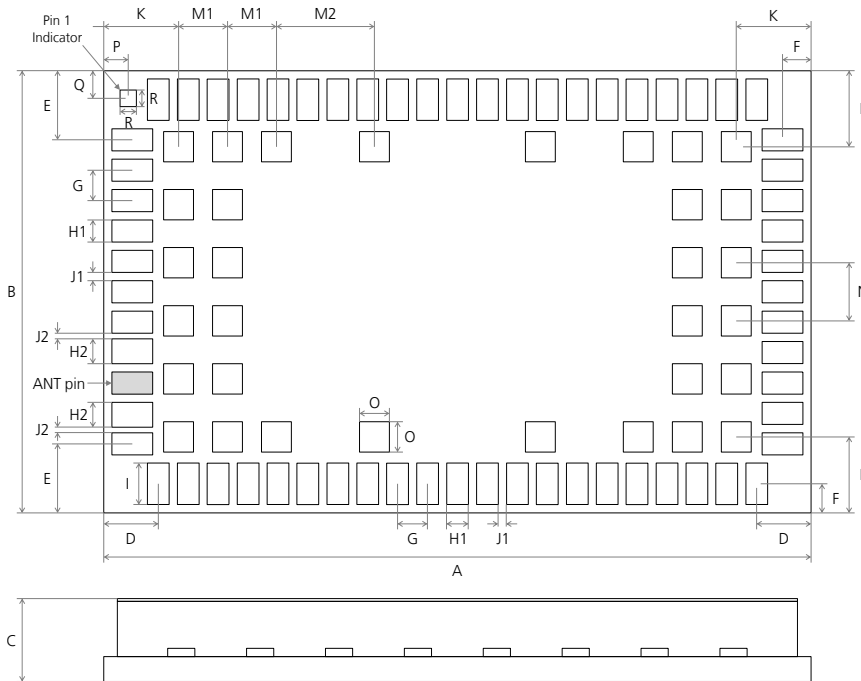

Figure 5: SARA-R5 series dimensions (bottom and side views)

Parameter	Description	Typical		Tolerance	
A	Module height [mm]	26.0	(1023.6 mil)	+0.20/-0.20	(+7.9/-7.9 mil)
B	Module width [mm]	16.0	(629.9 mil)	+0.20/-0.20	(+7.9/-7.9 mil)
C	Module thickness [mm]	2.2	(86.6 mil)	+0.25/-0.15	(+9.8/-5.9 mil)
D	Horizontal edge to lateral pin pitch [mm]	2.0	(78.7 mil)	+0.20/-0.20	(+7.9/-7.9 mil)
E	Vertical edge to lateral pin pitch [mm]	2.5	(98.4 mil)	+0.20/-0.20	(+7.9/-7.9 mil)
F	Edge to lateral pin pitch [mm]	1.05	(41.3 mil)	+0.20/-0.20	(+7.9/-7.9 mil)
G	Lateral pin to pin pitch [mm]	1.1	(43.3 mil)	+0.05/-0.05	(+2.0/-2.0 mil)
H1	Lateral pin height [mm]	0.8	(31.5 mil)	+0.05/-0.05	(+2.0/-2.0 mil)
H2	Lateral pin close to ANT height [mm]	0.9	(35.4 mil)	+0.05/-0.05	(+2.0/-2.0 mil)
I	Lateral pin width [mm]	1.5	(59.1 mil)	+0.05/-0.05	(+2.0/-2.0 mil)
J1	Lateral pin to pin distance [mm]	0.3	(11.8 mil)	+0.05/-0.05	(+2.0/-2.0 mil)
J2	Lateral pin to pin close to ANT distance [mm]	0.2	(7.9 mil)	+0.05/-0.05	(+2.0/-2.0 mil)
K	Horizontal edge to central pin pitch [mm]	2.75	(108.3 mil)	+0.20/-0.20	(+7.9/-7.9 mil)
L	Vertical edge to central pin pitch [mm]	2.75	(108.3 mil)	+0.20/-0.20	(+7.9/-7.9 mil)
M1	Central pin to pin horizontal pitch [mm]	1.8	(70.9 mil)	+0.05/-0.05	(+2.0/-2.0 mil)
M2	Central pin to pin horizontal pitch [mm]	3.6	(141.7 mil)	+0.05/-0.05	(+2.0/-2.0 mil)
N	Central pin to pin vertical pitch [mm]	2.1	(82.7 mil)	+0.05/-0.05	(+2.0/-2.0 mil)
O	Central pin height and width [mm]	1.1	(43.3 mil)	+0.05/-0.05	(+2.0/-2.0 mil)
P	Horizontal edge to pin 1 indicator pitch [mm]	0.9	(35.4 mil)	+0.20/-0.20	(+7.9/-7.9 mil)
Q	Vertical edge to pin 1 indicator pitch [mm]	1.0	(39.4 mil)	+0.20/-0.20	(+7.9/-7.9 mil)
R	Pin 1 indicator height and width [mm]	0.6	(23.6 mil)	+0.05/-0.05	(+2.0/-2.0 mil)
Weight	Module weight [g]	< 3			

Table 22 : SARA-R5 series dimensions

- Module height tolerance ± 0.20 mm may be exceeded close to the corners of the PCB due to the cutting process: in the worst cases, the height could be $+0.40$ mm longer than the typical value.
- For information regarding Footprint and Paste Mask recommended for the application board integrating the cellular module, see the SARA-R5 series system integration manual [2].

6 Qualification and approvals

6.1 Reliability tests

Tests for product family qualifications according to ISO 16750 “Road vehicles – Environmental conditions and testing for electrical and electronic equipment”, and appropriate standards.

6.1.1 Approvals

SARA-R5 series modules comply with the Directive 2011/65/EU of the European Parliament and the Council on the Restriction of Use of certain Hazardous Substances in Electrical and Electronic Equipment (EU RoHS 2) and its amendment Directive (EU) 2015/863 (EU RoHS 3).



SARA-R5 series modules are RoHS 3 compliant.

No natural rubbers, hygroscopic materials, or materials containing asbestos are employed.

[Table 23](#) summarizes the main approvals planned for SARA-R5 series modules.

Certification	SARA-R500S-00B	SARA-R510S-00B	SARA-R510M8S-00B
PTCRB	LTE Cat M1 bands 1,2,3,4,5,8,12,13,18,19,20,25,26,28	LTE Cat M1 bands 1,2,3,4,5,8,12,13,18,19,20,25,26,28	LTE Cat M1 bands 1,2,3,4,5,8,12,13,18,19,20,25,26,28
GCF	LTE Cat M1 bands 1,2,3,4,5,8,12,13,18,19,20,25,26,28	LTE Cat M1 bands 1,2,3,4,5,8,12,13,18,19,20,25,26,28	LTE Cat M1 bands 1,2,3,4,5,8,12,13,18,19,20,25,26,28
CE Europe	LTE Cat M1 bands 1,3,8,20,28	LTE Cat M1 bands 1,3,8,20,28	LTE Cat M1 bands 1,3,8,20,28
FCC US FCC ID	LTE Cat M1 bands 2,4,5,12,13,25,26 XPYUBX19KM01	LTE Cat M1 bands 2,4,5,12,13,25,26 XPYUBX19KM01	LTE Cat M1 bands 2,4,5,12,13,25,26 XPYUBX19KM01
ISED Canada ISED ID	LTE Cat M1 bands 2,4,5,12,13,25 8595A-UBX19KM01	LTE Cat M1 bands 2,4,5,12,13,25 8595A-UBX19KM01	LTE Cat M1 bands 2,4,5,12,13,25 8595A-UBX19KM01
Verizon	LTE Cat M1 bands 4,13	LTE Cat M1 bands 4,13	LTE Cat M1 bands 4,13
AT&T	LTE Cat M1 bands 2,4,5,12	LTE Cat M1 bands 2,4,5,12	LTE Cat M1 bands 2,4,5,12

Table 23: SARA-R5 series main certification approvals summary

-  For guidelines and notices about compliance with certification approvals requirements integrating the SARA-R5 series modules in the end-device, see the SARA-R5 series system integration manual [\[2\]](#).
-  For the complete list of planned approvals and for specific details on all country, conformance and network operators’ certifications available for all the different SARA-R5 series modules’ ordering numbers, including related certificates of compliancy, please contact your nearest u-blox office or sales representative.

7 Product handling & soldering

7.1 Packaging

SARA-R5 series modules are delivered as hermetically sealed, reeled tapes to enable efficient production, production lot set-up and tear-down. For more information about packaging, see the u-blox package information user guide [3].

7.1.1 Reels

SARA-R5 series modules are deliverable in quantities of 250 pieces on a reel. The modules are delivered using reel type B2 described in Figure 6 and in the u-blox package information user guide [3].

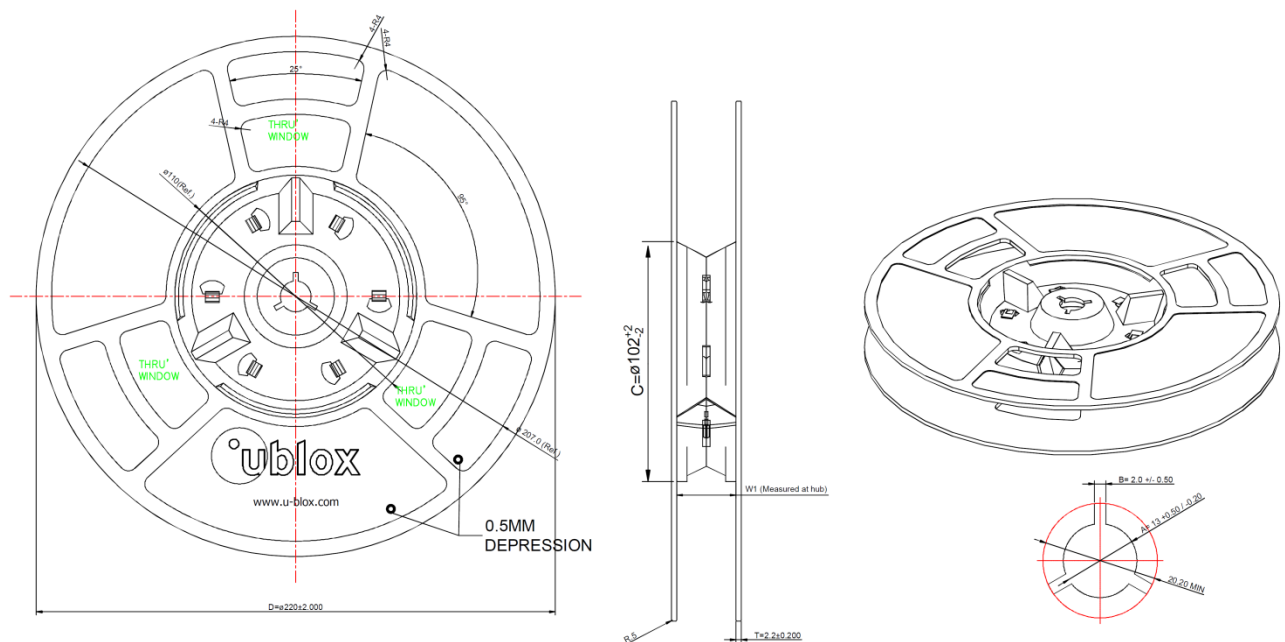

NOTE: ALL DIMENSIONS IN MILLIMETERS

Figure 6: SARA-R5 series modules reel

Parameter	Specification
Reel type	B2
Delivery quantity	250

Table 24: Reel information for SARA-R5 series modules

Quantities of less than 250 pieces are also available. Contact u-blox for more information.

7.1.2 Tapes

Figure 7 shows the position and the orientation of SARA-R5 series modules as they are delivered on the tape, while Figure 8 and Table 25 specify the dimensions of the tape.

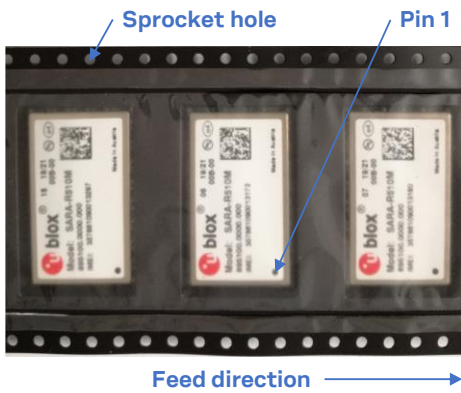

Figure 7: Orientation of SARA-R5 series modules on tape

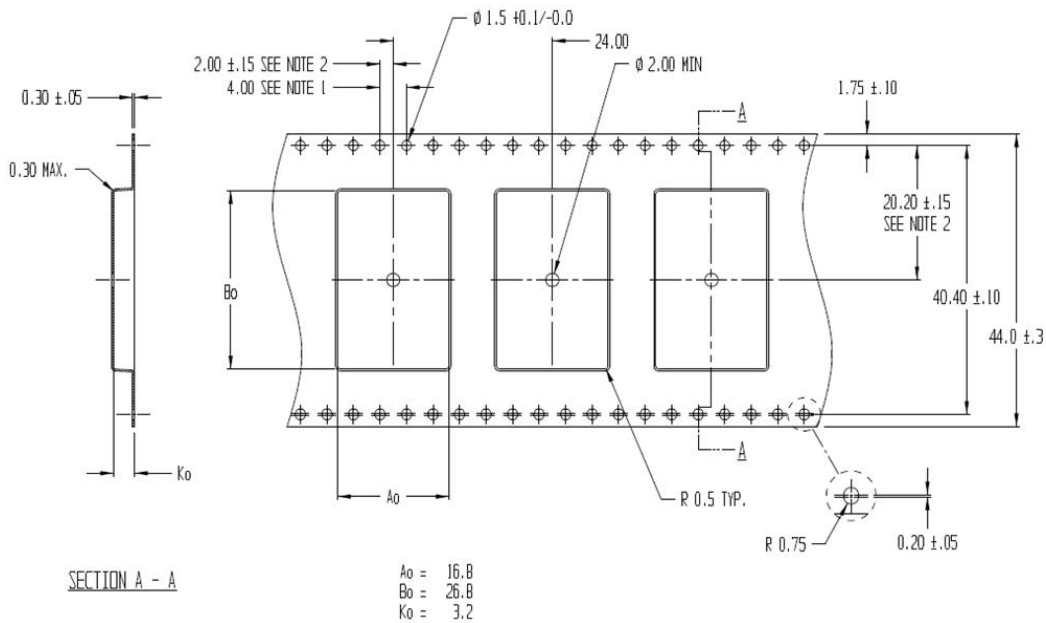



Figure 8: SARA-R5 series modules tape

Parameter	Typical value	Tolerance	Unit
A_0	16.8	0.2	mm
B_0	26.8	0.2	mm
K_0	3.2	0.2	mm

Table 25: SARA-R5 series tape dimensions (mm)

- 10 sprocket hole pitch cumulative tolerance ± 0.2 mm.
- Pocket position relative to sprocket hole is measured as true position of pocket, not pocket hole.
- A_0 and B_0 are calculated on a plane at a distance “R” above the bottom of the pocket.

7.2 Moisture sensitivity levels

-  SARA-R5 series modules are moisture sensitive devices (MSD) in accordance to the IPC/JEDEC specification.

The Moisture Sensitivity Level (MSL) relates to the packaging and handling precautions required. SARA-R5 series modules are rated at MSL level 4. For more information regarding moisture sensitivity levels, labeling, storage and drying, see the u-blox package information user guide [3].

-  For the MSL standard, see IPC/JEDEC J-STD-020 (can be downloaded from www.jedec.org).

7.3 Reflow soldering

Reflow profiles are to be selected according to u-blox recommendations (see the SARA-R5 series system integration manual [2]).

-  Failure to observe these recommendations can result in severe damage to the device!

7.4 ESD precautions

-  SARA-R5 series modules contain highly sensitive electronic circuitry and are Electrostatic Sensitive Devices (ESD). Handling SARA-R5 series modules without proper ESD protection may destroy or damage them permanently.

SARA-R5 series modules are Electrostatic Sensitive Devices (ESD) and require special ESD precautions typically applied to ESD sensitive components.

[Table 7](#) details the maximum ESD ratings of the SARA-R5 series modules.

Proper ESD handling and packaging procedures must be applied throughout the processing, handling and operation of any application that incorporates SARA-R5 series modules.

ESD precautions should be appropriately implemented on the application board where the module is mounted, as described in the SARA-R5 series system integration manual [2].

-  Failure to observe these precautions can result in severe damage to the device!

8 Labeling and ordering information

8.1 Product labeling

The labels of SARA-R5 series modules include important product information as described in this section. [Figure 9](#) illustrates the label of the SARA-R5 series modules, and includes: u-blox logo, production lot, Pb-free marking, product type number, IMEI number, certification information, and production country.

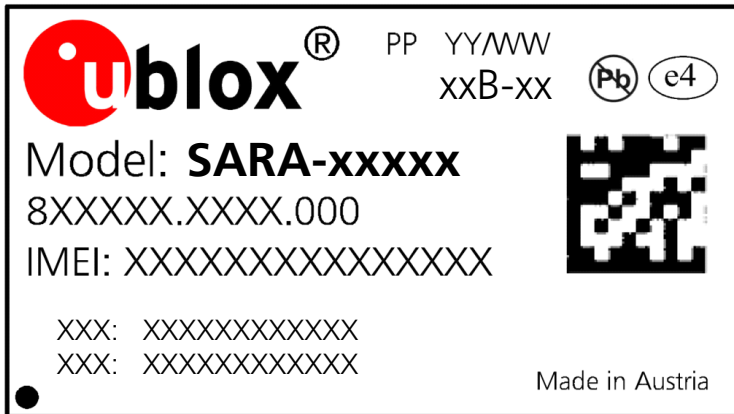

Figure 9: SARA-R5 series module label

8.2 Explanation of codes

Three different product code formats are used. The **Product Name** is used in documentation such as this data sheet and identifies all the u-blox products, independent of packaging and quality grade. The **Ordering Code** includes options and quality, while the **Type Number** includes the hardware and firmware versions. [Table 26](#) details these 3 different formats:

Format	Structure
Product Name	PPPP-TGVV(HH)(F)
Ordering Code	PPPP-TGVV(HH)(F)-MMQ
Type Number	PPPP-TGVV(HH)(F)-MMQ-XX

Table 26: Product code formats

[Table 27](#) explains the parts of the product code.

Code	Meaning	Example
PPPP	Form factor	SARA
TG	Platform (Technology and Generation) <ul style="list-style-type: none"> Dominant technology: G = GSM, U = HSUPA, C = CDMA 1xRTT, N = NB-IoT (LTE Cat NB1), R = LTE low data rate (Cat 1 and Cat M1), L = LTE high data rate (Cat 3 and above) Generation: 1...9 	R5
VV	Variant function set based on the same platform: 00...99	10
(HH)	GNSS generation (optional): M8 = u-blox M8, M9 = u-blox M9, ...	M8
(F)	Additional features (optional): S = secure cloud, ...	S
MM	Major product version: 00...99	00
Q	Product grade: C = standard, B = professional, A = automotive	B
XX	Minor product version: 00...99	Default value is 00

Table 27: Part identification code

8.3 Ordering information

Ordering No.	Product
SARA-R500S-00B	Secure cloud LTE Cat M1 module for multi-region use. 26.0 x 16.0 mm, 250 pieces/reel
SARA-R510S-00B	Secure cloud LTE Cat M1 module for multi-region use. Designed for extremely low current consumption in deep-sleep power saving mode (PSM). 26.0 x 16.0 mm, 250 pieces/reel
SARA-R510M8S-00B	Secure cloud LTE Cat M1 module for multi-region use. Designed with integrated u-blox M8 GNSS receiver, concurrently available with LTE network access. 26.0 x 16.0 mm, 250 pieces/reel

Table 28: Product ordering codes

Appendix

A Glossary

Abbreviation	Definition
3GPP	3 rd Generation Partnership Project
ADC	Analog to Digital Converter
AT	AT Command Interpreter Software Subsystem, or attention
BB	Baseband
BeiDou	Chinese satellite navigation system
BER	Bit Error Rate
Cat	Category
CBS	Cell Broadcast Service
CCC	China Compulsory Certificate
CE	Coverage Enhancement
CE	European Conformity
CEP	Circular Error Probable
CLK	Clock
CIoT	Cellular Internet of Things
CMOS	Complementary Metal-Oxide-Semiconductor
CoAP	Constrained Application Protocol
CS	Chip Select
CTS	Clear To Send
DC	Direct Current
DCD	Data Carrier Detect
DCS	Digital Cellular System
DDC	Display Data Channel
DL	Down Link (Reception)
DRX	Discontinuous Reception
DSR	Data Set Ready
DTE	Data Terminal Equipment
DTLS	Datagram Transport Layer Security
DTR	Data Terminal Ready
DUN	Dial-Up Networking
E-CID	Enhanced Cell Identity
eDRX	Extended Discontinuous Reception
EPS	Evolved Packet System
ESD	Electrostatic Discharge
E-UTRA	Evolved Universal Terrestrial Radio Access
FCC	Federal Communications Commission United States
FDD	Frequency Division Duplex
FOAT	Firmware (update) Over AT commands
FOTA	Firmware (update) Over-The-Air
FTP	File Transfer Protocol
FW	Firmware

Abbreviation	Definition
Galileo	European satellite navigation system
GCF	Global Certification Forum
GDI	Generic Digital Interface
GLONASS	Russian satellite navigation system
GND	Ground
GNSS	Global Navigation Satellite System
GPIO	General Purpose Input/Output
GPS	Global Positioning System
HARQ	Hybrid Automatic Repeat Request
HDLC	High-level Data Link Control
HTTP	HyperText Transfer Protocol
HW	Hardware
IEC	International Electrotechnical Commission
IFT	Federal Telecommunications Institute Mexico
I2C	Inter-Integrated Circuit
I2S	Inter-IC Sound
I/O	Input/Output
IMEI	International Mobile Equipment Identity
IP	Internet Protocol
ISED	Innovation, Science and Economic Development Canada
ISO	International Organization for Standardization
ITU	International Telecommunications Union
LGA	Land Grid Array
LNA	Low Noise Amplifier
LPWA	Low Power Wide Area
LTE	Long-Term Evolution
LTE-M	Long-Term Evolution – enhanced Machine Type Communication
LwM2M	Lightweight Machine-to-Machine protocol
M2M	Machine to Machine
MISO	Multiple Input Single Output
MOSI	Master Output Slave Input
MQTT	Message Queuing Telemetry Transport
MQTT-SN	Message Queuing Telemetry Transport for Sensor Networks
MSD	Moisture Sensitive Device
MSL	Moisture Sensitivity Level
MUX	Multiplexer
N/A	Not Applicable
NB-IoT	Narrowband Internet of Things
NCC	National Communications Commission Taiwan
PA	Power Amplifier
PCB	Printed Circuit Board
PCN	Product Change Notification / Sample Delivery Note / Information Note
PMU	Power Management Unit
POS	Power On Signal
PPS	Pulse Per Second
PSM	Power Saving Mode

Abbreviation	Definition
PTCRB	PCS Type Certification Review Board
PUCCH	Physical Uplink Control Channel
QPSK	Quadrature Phase Shift Keying modulation
QZSS	Quasi-Zenith Satellite System
RACH	Random Access Channel
RAM	Random Access Memory
RAT	Radio Access Technology
RF	Radio Frequency
RI	Ring Indicator
RIL	Radio Interface Layer
RRC	Radio Resource Control
RTC	Real Time Clock
RTS	Request To Send
Rx	Reception
SAW	Surface Acoustic Wave
SBAS	Satellite-Based Augmentation System
SCL	Serial Clock
SDA	Serial Data
SDIO	Secure Digital Input Output
SIM	Subscriber Identity Module
SMS	Short Message Service
SPG	Standard Precision GNSS
SPI	Serial Peripheral Interface
SSL	Secure Socket Layer
TBS	Transport Block Size
TCP	Transmission Control Protocol
TDD	Time Division Duplex
TLS	Transport Layer Security
TS	Technical Specification
Tx	Transmission
TXD	Transmit Data
UART	Universal Asynchronous Receiver/Transmitter
uCSP	u-blox Common Services Platform
UDP	User Datagram Protocol
UE	User Equipment
uFOTA	u-blox Firmware (update) Over-The-Air
UL	Uplink (Transmission)
URC	Unsolicited Result Code
USB	Universal Serial Bus
VoLTE	Voice over LTE
VSWR	Voltage Standing Wave Ratio
WA	Word Alignment

Table 29: Explanation of the abbreviations and terms used

Related documents

- [1] u-blox SARA-R5 series AT commands manual, [UBX-19047455](#)
- [2] u-blox SARA-R5 series system integration manual, [UBX-19041356](#)
- [3] u-blox package information user guide, [UBX-14001652](#)
- [4] 3GPP TS 27.007 - AT command set for User Equipment (UE)
- [5] 3GPP TS 27.005 - Use of Data Terminal Equipment - Data Circuit terminating Equipment (DTE - DCE) interface for Short Message Service (SMS) and Cell Broadcast Service (CBS)
- [6] 3GPP TS 27.010 - Terminal Equipment to User Equipment (TE-UE) multiplexer protocol
- [7] 3GPP TS 36.521-1 - Evolved Universal Terrestrial Radio Access; User Equipment conformance specification; Radio transmission and reception; Part 1: Conformance Testing
- [8] ITU-T Recommendation V24 - List of definitions for interchange circuits between Data Terminal Equipment (DTE) and Data Connection Equipment (DCE)
- [9] Universal Serial Bus Revision 2.0 specification, <https://www.usb.org/>
- [10] I2C-bus specification and user manual - NXP semiconductors, <https://www.nxp.com/docs/en/user-guide/UM10204.pdf>

 For regular updates to u-blox documentation and to receive product change notifications, register on our homepage (www.u-blox.com).

Revision history

Revision	Date	Name	Comments
R01	02-Aug-2019	fvid / sses	Initial release
R02	17-Oct-2019	fvid	Updated GPIO section. Updated RESET_N and generic digital interfaces electrical specifications. Updated normal operating temperature.
R03	07-Nov-2019	sses	Updated document products applicability. Updated Power-on, Power-off and Reset sections. Updated GPIO section. Updated pin 2 name and function. Updated absolute maximum ratings. Minor other corrections and clarifications.
R04	20-Dec-2019	fvid / sses	Added current consumption and LTE Cat M1 receiver sensitivity figures. Updated UART section. Updated GPIO section. Updated DDC (I2C) electrical specifications. Update the module thickness, Minor other corrections and clarifications.
R05	06-Mar-2020	fvid / sses	Extended the document applicability to SARA-R500S-00B. NB-IoT radio access technology not supported by "00" products version. GPIO, Power-on, Power-off, Reset sections and characteristics updated. Added some current consumption figures. Other minor corrections and clarifications.
R06	15-Jul-2020	sses / fvid	Updated document products status. Updated GPIO section and PWR_ON timings. Added some current consumption figures, and GNSS performance figures. Other minor corrections and clarifications.

Contact

For complete contact information, visit us at www.u-blox.com.

u-blox Offices

North, Central and South America

u-blox America, Inc.

Phone: +1 703 483 3180
E-mail: info_us@u-blox.com

Regional Office West Coast:

Phone: +1 408 573 3640
E-mail: info_us@u-blox.com

Technical Support:

Phone: +1 703 483 3185
E-mail: support@u-blox.com

Headquarters

Europe, Middle East, Africa

u-blox AG

Phone: +41 44 722 74 44
E-mail: info@u-blox.com
Support: support@u-blox.com

Asia, Australia, Pacific

u-blox Singapore Pte. Ltd.

Phone: +65 6734 3811
E-mail: info_ap@u-blox.com
Support: support_ap@u-blox.com

Regional Office Australia:

Phone: +61 2 8448 2016
E-mail: info_anz@u-blox.com
Support: support_ap@u-blox.com

Regional Office China (Beijing):

Phone: +86 10 68 133 545
E-mail: info_cn@u-blox.com
Support: support_cn@u-blox.com

Regional Office China (Chongqing):

Phone: +86 23 6815 1588
E-mail: info_cn@u-blox.com
Support: support_cn@u-blox.com

Regional Office China (Shanghai):

Phone: +86 21 6090 4832
E-mail: info_cn@u-blox.com
Support: support_cn@u-blox.com

Regional Office China (Shenzhen):

Phone: +86 755 8627 1083
E-mail: info_cn@u-blox.com
Support: support_cn@u-blox.com

Regional Office India:

Phone: +91 80 405 092 00
E-mail: info_in@u-blox.com
Support: support_in@u-blox.com

Regional Office Japan (Osaka):

Phone: +81 6 6941 3660
E-mail: info_jp@u-blox.com
Support: support_jp@u-blox.com

Regional Office Japan (Tokyo):

Phone: +81 3 5775 3850
E-mail: info_jp@u-blox.com
Support: support_jp@u-blox.com

Regional Office Korea:

Phone: +82 2 542 0861
E-mail: info_kr@u-blox.com
Support: support_kr@u-blox.com

Regional Office Taiwan:

Phone: +886 2 2657 1090
E-mail: info_tw@u-blox.com
Support: support_tw@u-blox.com