

DESCRIPTION

The PT32 microcontrollers is a series of low-power microcontrollers incorporating a high-performance ARM Cortex™-M0 32-bit RISC core. It operates at a maximum 48 MHz frequency and features 32 Kbytes of Flash and 4 Kbytes of SRAM. A comprehensive set of power-saving modes allows it to be employed in low-power applications. Extensive range of enhanced peripherals and I/Os are available allowing the device to be adopted in different application. A comprehensive set of power-saving modes allows it to be employed in low-power applications. The Flash program memory can be reprogrammed in-system through the SWD interface.

The PT32U301 MCUs give you any essential functionality as a General-purpose MCU. With its highly customizable peripherals, it eases the process of making your own ideal product.

PT32U301 microcontroller peripheral set also includes an External Bus Interface, 2x UARTs, 1X I2C, 1 SPI, 3x general-purpose 16/32-bit timers, an RTC, 3x PWM, an ADC and four analog comparators.

FEATURES

- ARM Cortex M0 Processor
- Performance up to 48 MHz
- Flash memory 32K-Byte
- System SRAM 4K-Byte
- Power control
 - POR/PDR
 - PVD
- Low power mode
 - Sleep mode
 - Stop mode
 - Standby mode
- Divers Peripherals
 - Up to 45 GPIOs
 - 16/32-bit timer * 6
 - WDT/RTC
 - 8 channel 12-bit ADC
 - 4 Comparator with window comparison
 - 2 UART
 - I2C with master/slave mode
 - SPI with variable bit length (4-16 bits)

BLOCK DIAGRAM

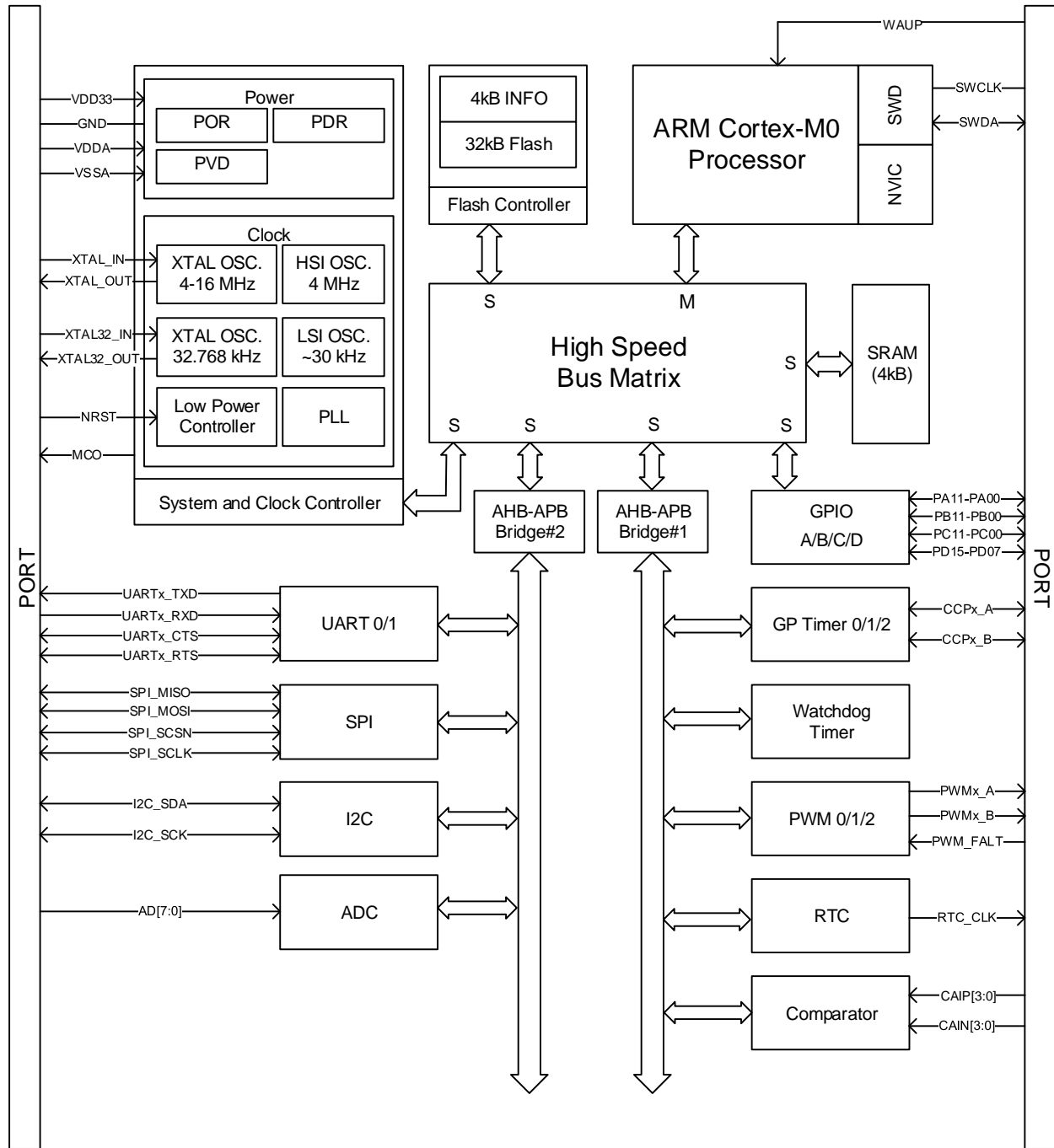

1. ORDER INFORMATION

Valid Part Number	Package Type	Top Code
PT32U301	LQFP 48	PT32U301
PT32U301	LQFP 32	PT32U301
PT32U301	SSOP 24	PT32U301
PT32U301	SOP 16	PT32U301
PT32U301	SOP 8	PT32U301

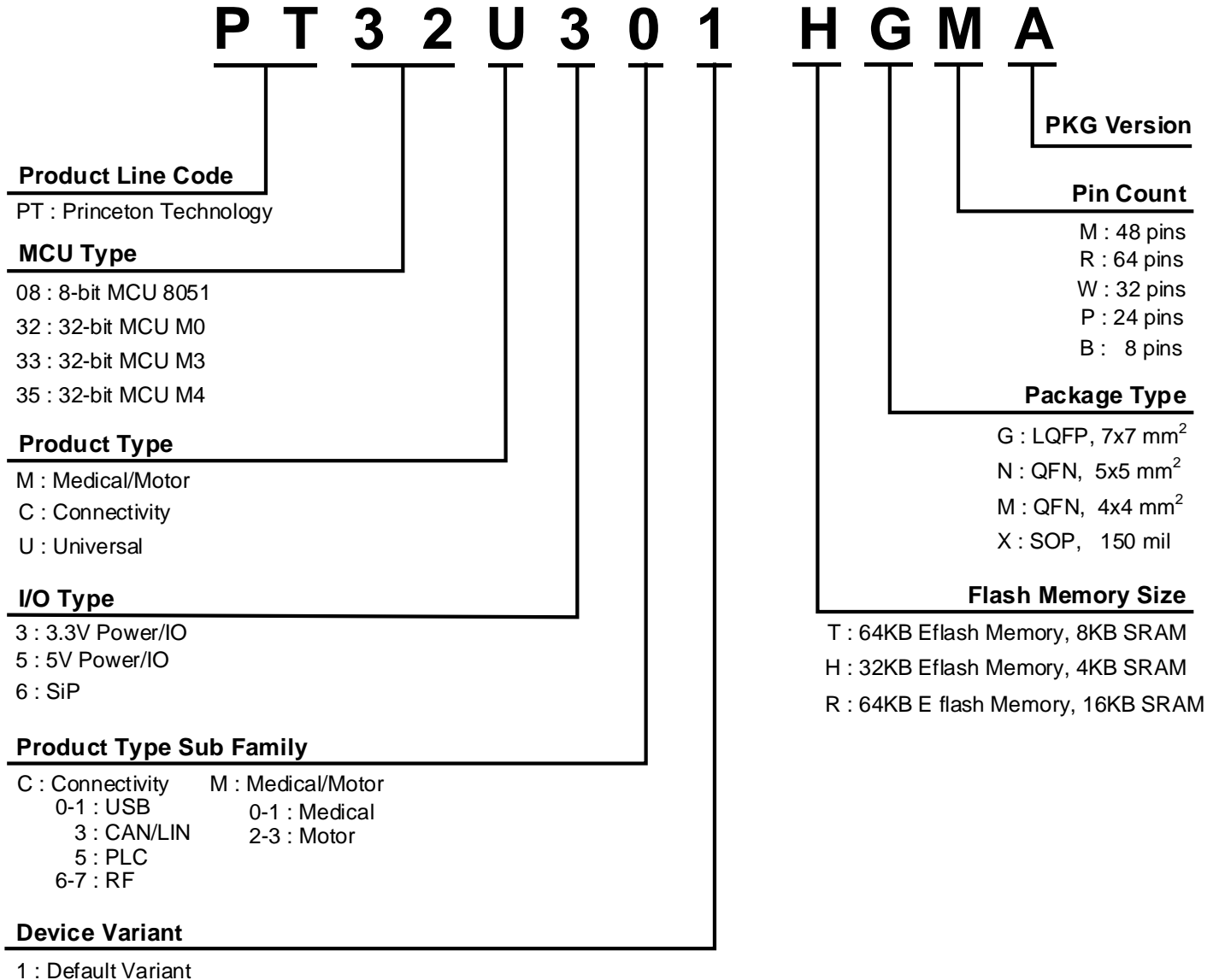

2. PIN CONFIGURATION

LQFP - 48

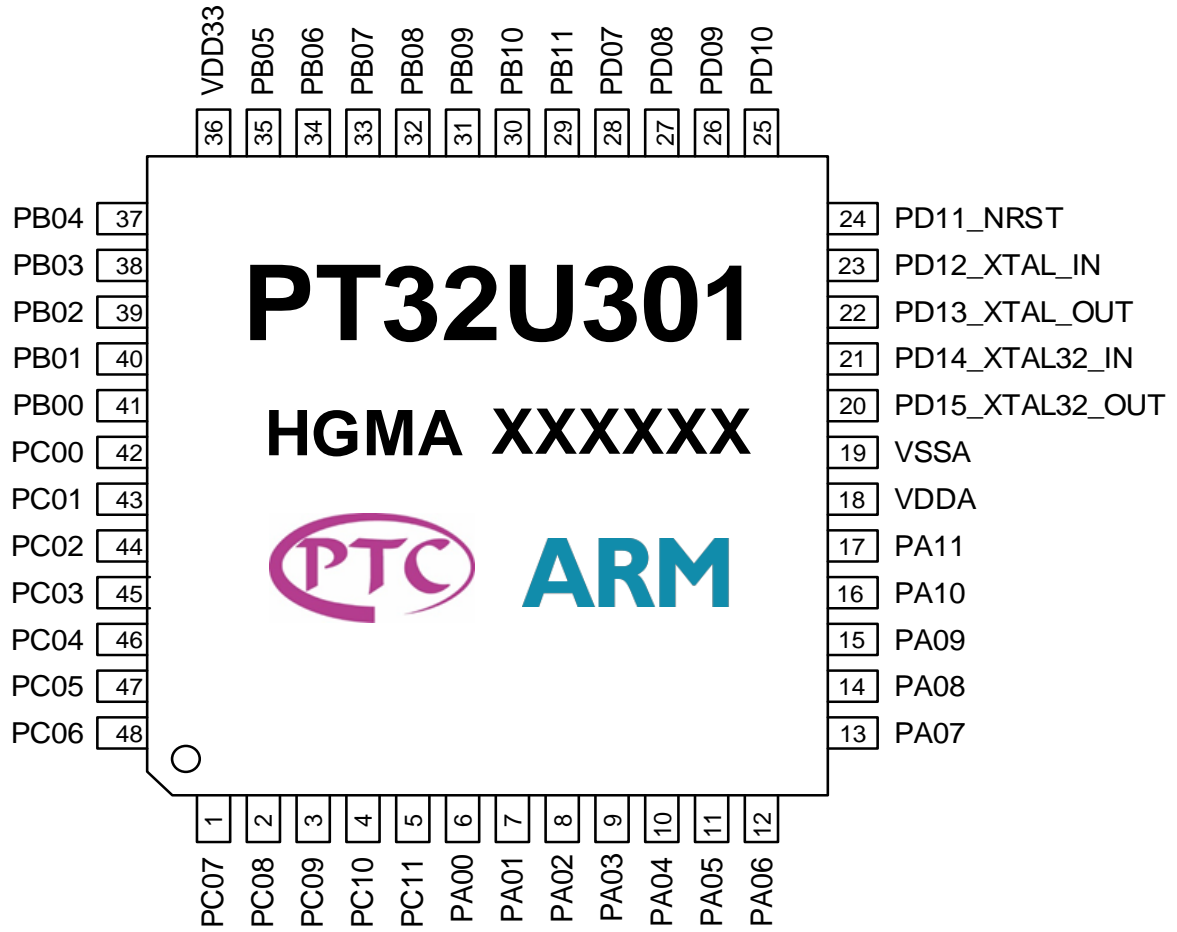

LQFP - 32

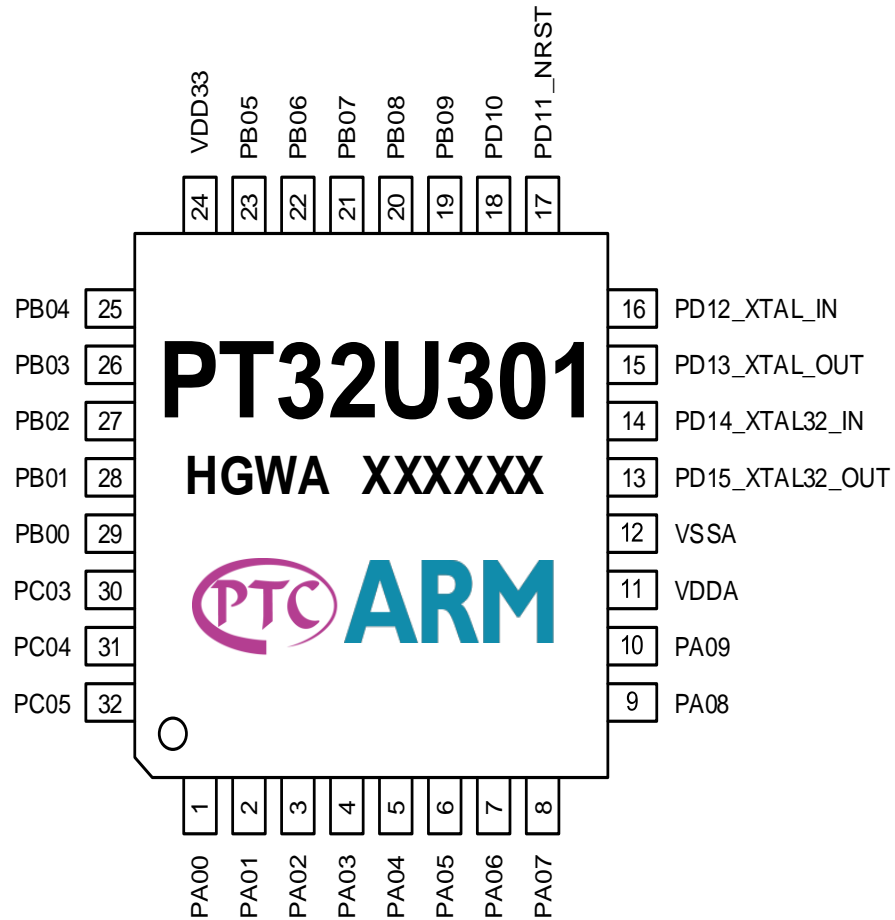

SSOP - 24

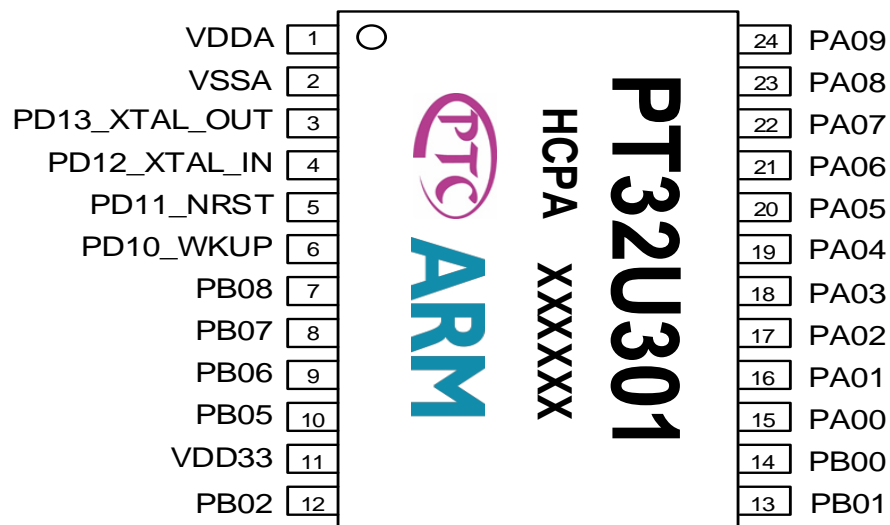

SOP - 16

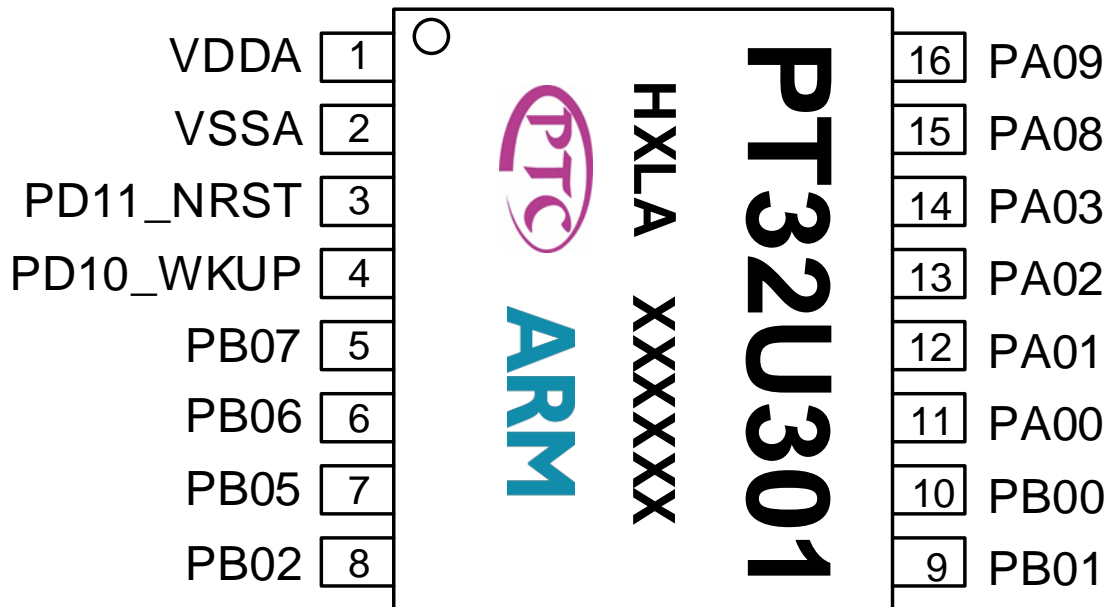

SOP - 8

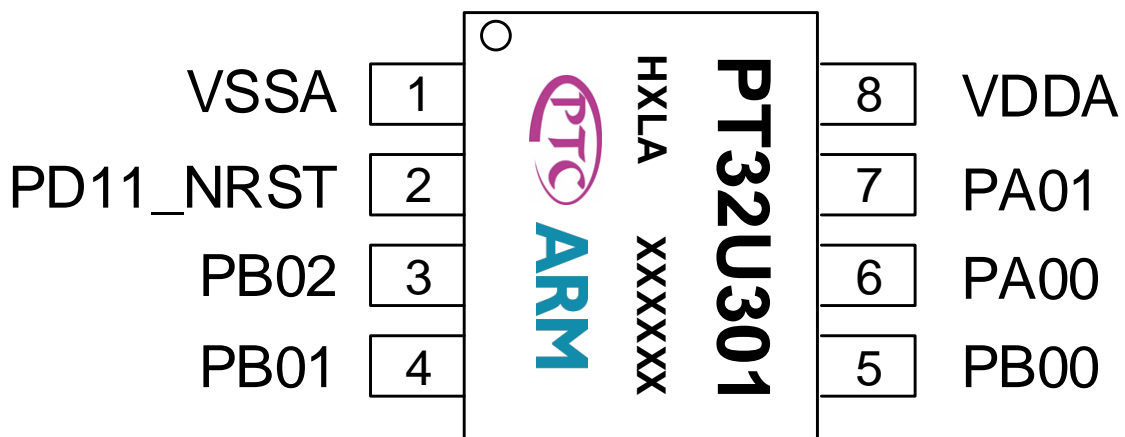

3. PIN DESCRIPTION

Each GPIO line can be assigned to one of the peripheral functions. The following table lists out the pin name of all packages and its respective available alternate function.

Pin Name	Pin Type	Description	Pin No.				
			LQFP48	LQFP32	SSOP24	SOP16	SOP8
PC07	I/O	General Purpose Digital I/O Pin	1				
PC08	I/O	General Purpose Digital I/O Pin	2				
PC09	I/O	General Purpose Digital I/O Pin	3				
PC10	I/O	General Purpose Digital I/O Pin	4				
PC11	I/O	General Purpose Digital I/O Pin	5				
PA00	I/O	General Purpose Digital I/O Pin	6	1	15	11	6
PA01	I/O	General Purpose Digital I/O Pin	7	2	16	12	7
PA02	I/O	General Purpose Digital I/O Pin	8	3	17	13	
PA03	I/O	General Purpose Digital I/O Pin	9	4	18	14	
PA04	I/O	General Purpose Digital I/O Pin	10	5	19		
PA05	I/O	General Purpose Digital I/O Pin	11	6	20		
PA06	I/O	General Purpose Digital I/O Pin	12	7	21		
PA07	I/O	General Purpose Digital I/O Pin	13	8	22	15	
PA08	I/O	General Purpose Digital I/O Pin	14	9	23	16	
PA09	I/O	General Purpose Digital I/O Pin	15	10	24		
PA10	I/O	General Purpose Digital I/O Pin	16				
PA11	I/O	General Purpose Digital I/O Pin	17				
VDDA	Supply	Analog Voltage Supply	18	11	1	1	8
VSSA	Ground	Analog Ground	19	12	2	2	1
PD15_XTAL32_OUT	I/O	General Purpose Digital I/O Pin/Crystal Output	20	13			
PD14_XTAL32_IN	I/O	General Purpose Digital I/O Pin/Crystal Input	21	14			
PD13_XTAL_OUT	I/O	General Purpose Digital I/O Pin/Crystal Output	22	15	3		
PD12_XTAL_IN	I/O	General Purpose Digital I/O Pin/Crystal input	23	16	4		
PD11_NRST	I/O	General Purpose Digital I/O Pin/Reset	24	17	5	3	2
PD10	I/O	General Purpose Digital I/O Pin	25	18	6	4	
PD09	I/O	General Purpose Digital I/O Pin	26	19			
PD08	I/O	General Purpose Digital I/O Pin	27	20			
PD07	I/O	General Purpose Digital I/O Pin	28				
PB11	I/O	General Purpose Digital I/O Pin	29				
PB10	I/O	General Purpose Digital I/O Pin	30				
PB09	I/O	General Purpose Digital I/O Pin	31				
PB08	I/O	General Purpose Digital I/O Pin	32		7		
PB07	I/O	General Purpose Digital I/O Pin	33	21	8	5	
PB06	I/O	General Purpose Digital I/O Pin	34	22	9	6	
PB05	I/O	General Purpose Digital I/O Pin	35	23	10	7	
VDD33	Supply	Voltage Supply	36	24	11		
PB04	I/O	General Purpose Digital I/O Pin	37	25			
PB03	I/O	General Purpose Digital I/O Pin	38	26			
PB02	I/O	General Purpose Digital I/O Pin	39	27	12	8	3



Pin Name	Pin Type	Description	Pin No.				
			LQFP48	LQFP32	SSOP24	SOP16	SOP8
PB01	I/O	General Purpose Digital I/O Pin	40	28	13	9	4
PB00	I/O	General Purpose Digital I/O Pin	41	30	14	10	5
PC00	I/O	General Purpose Digital I/O Pin	42				
PC01	I/O	General Purpose Digital I/O Pin	43				
PC02	I/O	General Purpose Digital I/O Pin	44				
PC03	I/O	General Purpose Digital I/O Pin	45	30			
PC04	I/O	General Purpose Digital I/O Pin	46	31			
PC05	I/O	General Purpose Digital I/O Pin	47	32			
PC06	I/O	General Purpose Digital I/O Pin	48				

IMPORTANT NOTICE

Princeton Technology Corporation (PTC) reserves the right to make corrections, modifications, enhancements, improvements, and other changes to its products and to discontinue any product without notice at any time.

PTC cannot assume responsibility for use of any circuitry other than circuitry entirely embodied in a PTC product. No circuit patent licenses are implied.

Princeton Technology Corp.
2F, 233-1, Baociao Road,
Sindian, Dist., New Taipei City 23145, Taiwan
Tel : 886-2-66296288
Fax: 886-2-29174598
<http://www.princeton.com.tw>