

LL3-TS40

LL3

FIBER-OPTIC SENSORS AND FIBERS

SICK
Sensor Intelligence.

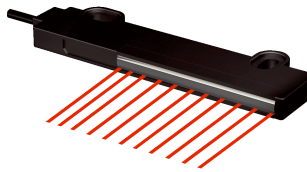

Ordering information

Type	Part no.
LL3-TS40	5323971

Other models and accessories → www.sick.com/LL3

Detailed technical data

Features

Device type	Fibers
Detection principle	Through-beam system
For fiber-optic sensor	GLL170(T), WLL180T, WLL24 Ex
Fiber length	2 m
Fiber material	Polymethylmethacrylat (PMMA)
Jacket material	Polyethylen (PE)
Fiber head material	Polyamid (PA)
Outer diameter, fiber-optic cable connection	2.2 mm
Fiber-optic cable cuttable	✓ ¹⁾
Fiber-optic head design	Flat type, 90° deflection, Array
Array width	40 mm
Fiber arrangement	Multi-fiber – linear arrangement
Core structure	Ø 1,0 mm Multi-fiber – linear arrangement
Bend radius, fibre-optic cable	2 mm
Angle of dispersion < 60°	Yes
Compatibility with infrared light (1,450 nm)	No
Ambient operating temperature	-40 °C ... +60 °C
Application	High flexible (static), Area detection
Highly flexible/elastic fibers (bend radius 1–4 mm)	No
Adapter end sleeves required	No
Angle of dispersion	24.27°
Integrated lens	Yes
Minimal object diameter	0.4 mm ²⁾
Special features	Long fiber optic cable cell
Included with delivery	Mounting, 4 x M4 Phillips-head screw, FC fiber cutter (5304141), protective cladding for fiber head
Compatibility tip adapters	No

¹⁾ FC fiber optic cable cutter included in delivery.

²⁾ Minimum detectable object was determined at optimum measuring distance and optimum setting.

Classifications

ECl@ss 5.0	27270905
-------------------	----------

ECI@ss 5.1.4	27270905
ECI@ss 6.0	27270905
ECI@ss 6.2	27270905
ECI@ss 7.0	27270905
ECI@ss 8.0	27270905
ECI@ss 8.1	27270905
ECI@ss 9.0	27270905
ETIM 5.0	EC002651
ETIM 6.0	EC002651
UNSPSC 16.0901	39121528

Sensing ranges with WLL180T

Operating mode 16 µs	3,000 mm
Operating mode 70 µs	4,000 mm
Operating mode 250 µs	4,000 mm
Operating mode 2 ms	4,000 mm
Operating mode 8 ms	4,000 mm

Sensing ranges with GLL170

Operating mode 250 µs	3,500 mm
------------------------------	----------

Sensing ranges with GLL170T

Operating mode 50 µs	3,500 mm
Operating mode 250 µs	3,500 mm

Dimensional drawing (Dimensions in mm (inch))

LL3-TS40

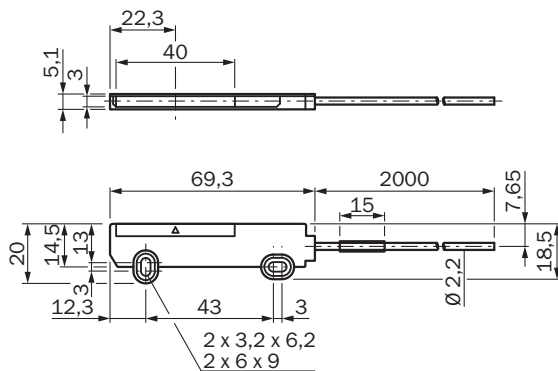

SICK AT A GLANCE

SICK is one of the leading manufacturers of intelligent sensors and sensor solutions for industrial applications. A unique range of products and services creates the perfect basis for controlling processes securely and efficiently, protecting individuals from accidents and preventing damage to the environment.

We have extensive experience in a wide range of industries and understand their processes and requirements. With intelligent sensors, we can deliver exactly what our customers need. In application centers in Europe, Asia and North America, system solutions are tested and optimized in accordance with customer specifications. All this makes us a reliable supplier and development partner.

Comprehensive services complete our offering: SICK LifeTime Services provide support throughout the machine life cycle and ensure safety and productivity.

For us, that is “Sensor Intelligence.”

WORLDWIDE PRESENCE:

Contacts and other locations –www.sick.com