

Description

The 9DBL08 devices are 3.3V members of IDT's Full-Featured PCIe family. The 9DBL08 supports PCIe Gen1-4 Common Clocked (CC) and PCIe Separate Reference Independent Spread (SRIS) systems. It offers a choice of integrated output terminations providing direct connection to 85Ω or 100Ω transmission lines. The 9DBL08P1 can be factory programmed with a user-defined power up default SMBus configuration.

Recommended Application

PCIe Gen1-4 clock distribution for Riser Cards, Storage, Networking, JBOD, Communications, Access Points

Output Features

- 8 – 1-200 MHz Low-Power (LP) HCSL DIF pairs
 - 9DBL0841 default Z_{OUT} = 100Ω
 - 9DBL0851 default Z_{OUT} = 85Ω
 - 9DBL08P1 factory programmable defaults
- Easy AC-coupling to other logic families, see IDT application note [AN-891](#)

Key Specifications

- PCIe Gen1-2-3-4 CC compliant in ZDB mode
- PCIe Gen2 SRIS compliant in ZDB mode
- Supports PCIe Gen2-3 SRIS in fan-out mode
- DIF cycle-to-cycle jitter <50ps
- DIF output-to-output skew < 50ps
- Bypass mode additive phase jitter is 0 ps typical rms for PCIe
- Bypass mode additive phase jitter 160fs rms typ. @ 156.25M (1.5M to 10M)

Features/Benefits

- Direct connection to 100Ω (0841) or 85Ω (0851) transmission lines; saves 32 resistors compared to standard PCIe devices
- 211mW typical power consumption (PLL mode@3.3V); eliminates thermal concerns
- VDDIO allows 35% power savings at optional 1.05V; maximum power savings
- SMBus-selectable features allows optimization to customer requirements:
 - control input polarity
 - control input pull up/downs
 - slew rate for each output
 - differential output amplitude
 - output impedance for each output
 - 50, 100, 125MHz operating frequency
- Customer defined SMBus power up default can be programmed into P1 device; allows exact optimization to customer requirements
- OE# pins; support DIF power management
- HCSL-compatible differential input; can be driven by common clock sources
- Spread Spectrum tolerant; allows reduction of EMI
- Pin/SMBus selectable PLL bandwidth and PLL Bypass; minimize phase jitter for each application
- Outputs blocked until PLL is locked; clean system start-up
- Device contains default configuration; SMBus interface not required for device operation
- Three selectable SMBus addresses; multiple devices can easily share an SMBus segment
- Space saving 48-pin 6x6mm VFQFPN; minimal board space

Block Diagram

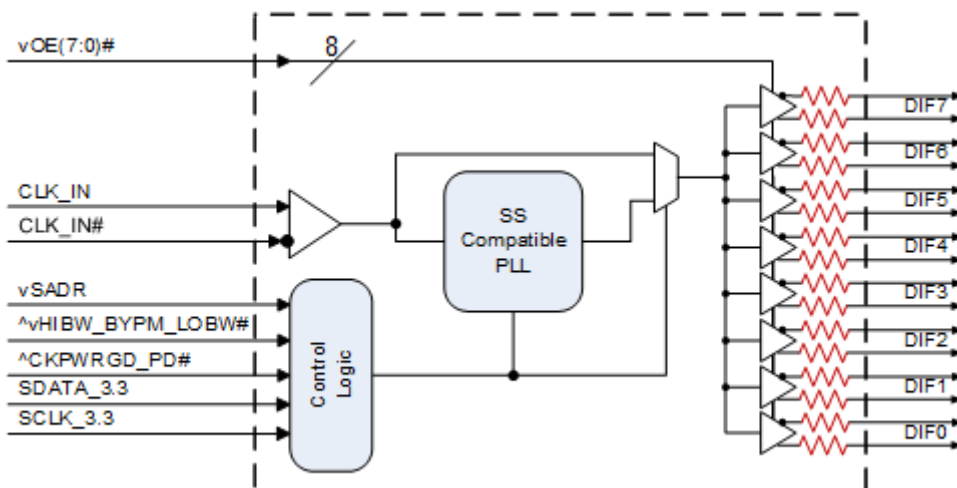

Note: Resistors default to internal on 41/51 devices. P1 devices have programmable default impedances on an output-by-output basis.

Pin Configuration

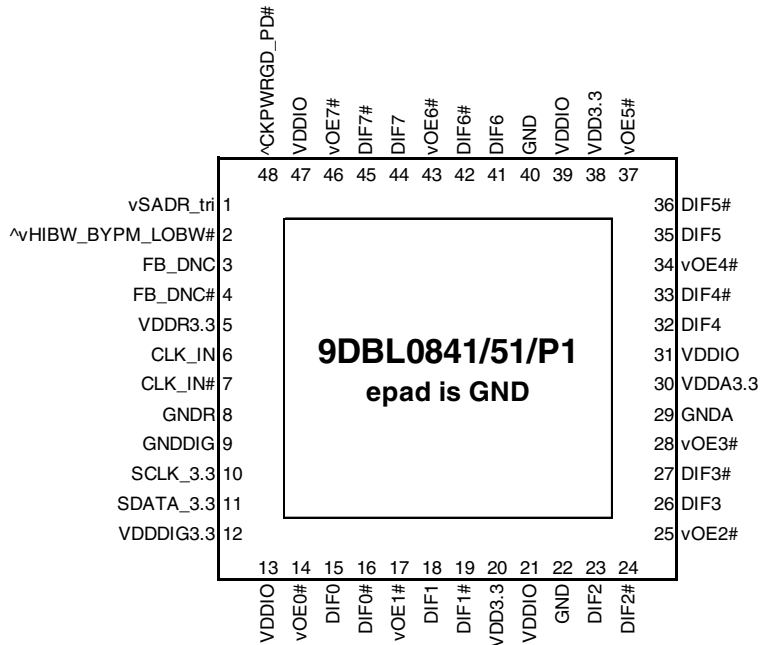

48-pin VFQFPN, 6x6 mm, 0.4mm pitch

- ^v prefix indicates internal 120KOhm pull up *AND* pull down resistor (biased to VDD/2)
- v prefix indicates internal 120KOhm pull down resistor
- ^ prefix indicates internal 120KOhm pull up resistor

SMBus Address Selection Table

	SADR	Address	+ Read/Write bit
State of SADR on first application of CKPWRGD_PD#	0	1101011	x
	M	1101100	x
	1	1101101	x

Note: If not using CKPWRGD (CKPWRGD tied to VDD3.3), all 3.3V VDD need to transition from 2.1V to 3.135V in <300usec.

Power Management Table

CKPWRGD_PD#	CLK_IN	SMBus OEx bit	OEx# Pin	DIFx		PLL
				True O/P	Comp. O/P	
0	X	X	X	Low ¹	Low ¹	Off
1	Running	0	X	Low ¹	Low ¹	On ²
1	Running	1	0	Running	Running	On ²
1	Running	1	1	Low ¹	Low ¹	On ²

1. The output state is set by B11[1:0] (Low/Low default)
2. If Bypass mode is selected, the PLL will be off, and outputs will be running.

Power Connections

Pin Number			Description
VDD	VDDIO	GND	
5		8	Input receiver analog
12		9	Digital Power
20,31,38	13,21,31,39,47	22, 29,40,49	DIF outputs
30		29	PLL Analog

PLL Operating Mode

HiBW_BypM_LoBW#	MODE	Byte1 [7:6] Readback	Byte1 [4:3] Control
0	PLL Lo BW	00	00
M	Bypass	01	01
1	PLL Hi BW	11	11

Pin Descriptions

PIN #	PIN NAME	TYPE	DESCRIPTION
1	vSADR_tri	LATCHED IN	Tri-level latch to select SMBus Address. See SMBus Address Selection Table.
2	^vHIBW_BYPM_LOBW#	LATCHED IN	Trilevel input to select High BW, Bypass or Low BW mode. This pin is biased to VDD/2 (Bypass mode) with internal pull up/pull down resistors. See PLL Operating Mode Table for Details.
3	FB_DNC	DNC	True clock of differential feedback. The feedback output and feedback input are connected internally on this pin. Do not connect anything to this pin.
4	FB_DNC#	DNC	Complement clock of differential feedback. The feedback output and feedback input are connected internally on this pin. Do not connect anything to this pin.
5	VDDR3.3	PWR	3.3V power for differential input clock (receiver). This VDD should be treated as an Analog power rail and filtered appropriately.
6	CLK_IN	IN	True Input for differential reference clock.
7	CLK_IN#	IN	Complementary Input for differential reference clock.
8	GNDR	GND	Analog Ground pin for the differential input (receiver)
9	GNDDIG	GND	Ground pin for digital circuitry
10	SCLK_3.3	IN	Clock pin of SMBus circuitry, 3.3V tolerant.
11	SDATA_3.3	I/O	Data pin for SMBus circuitry, 3.3V tolerant.
12	VDDDIG3.3	PWR	3.3V digital power (dirty power)
13	VDDIO	PWR	Power supply for differential outputs
14	vOE0#	IN	Active low input for enabling output 0. This pin has an internal pull-down. 1 =disable outputs, 0 = enable outputs
15	DIF0	OUT	Differential true clock output
16	DIF0#	OUT	Differential Complementary clock output
17	vOE1#	IN	Active low input for enabling output 1. This pin has an internal pull-down. 1 =disable outputs, 0 = enable outputs
18	DIF1	OUT	Differential true clock output
19	DIF1#	OUT	Differential Complementary clock output
20	VDD3.3	PWR	Power supply, nominal 3.3V
21	VDDIO	PWR	Power supply for differential outputs
22	GND	GND	Ground pin.
23	DIF2	OUT	Differential true clock output
24	DIF2#	OUT	Differential Complementary clock output
25	vOE2#	IN	Active low input for enabling output 2. This pin has an internal pull-down. 1 =disable outputs, 0 = enable outputs
26	DIF3	OUT	Differential true clock output
27	DIF3#	OUT	Differential Complementary clock output
28	vOE3#	IN	Active low input for enabling output 3. This pin has an internal pull-down. 1 =disable outputs, 0 = enable outputs
29	GNDA	GND	Ground pin for the PLL core.
30	VDDA3.3	PWR	3.3V power for the PLL core.
31	VDDIO	PWR	Power supply for differential outputs
32	DIF4	OUT	Differential true clock output
33	DIF4#	OUT	Differential Complementary clock output
34	vOE4#	IN	Active low input for enabling output 4. This pin has an internal pull-down. 1 =disable outputs, 0 = enable outputs
35	DIF5	OUT	Differential true clock output
36	DIF5#	OUT	Differential Complementary clock output
37	vOE5#	IN	Active low input for enabling output 5. This pin has an internal pull-down. 1 =disable outputs, 0 = enable outputs
38	VDD3.3	PWR	Power supply, nominal 3.3V
39	VDDIO	PWR	Power supply for differential outputs

Pin Descriptions (cont.)

PIN #	PIN NAME	TYPE	DESCRIPTION
40	GND	GND	Ground pin.
41	DIF6	OUT	Differential true clock output
42	DIF6#	OUT	Differential Complementary clock output
43	vOE6#	IN	Active low input for enabling output 6. This pin has an internal pull-down. 1 =disable outputs, 0 = enable outputs
44	DIF7	OUT	Differential true clock output
45	DIF7#	OUT	Differential Complementary clock output
46	vOE7#	IN	Active low input for enabling output 7. This pin has an internal pull-down. 1 =disable outputs, 0 = enable outputs
47	VDDIO	PWR	Power supply for differential outputs
48	^CKPWRGD_PD#	IN	Input notifies device to sample latched inputs and start up on first high assertion. Low enters Power Down Mode, subsequent high assertions exit Power Down Mode. This pin has internal pull-up resistor.
49	EPAD	GND	Connect to Ground.

Test Loads

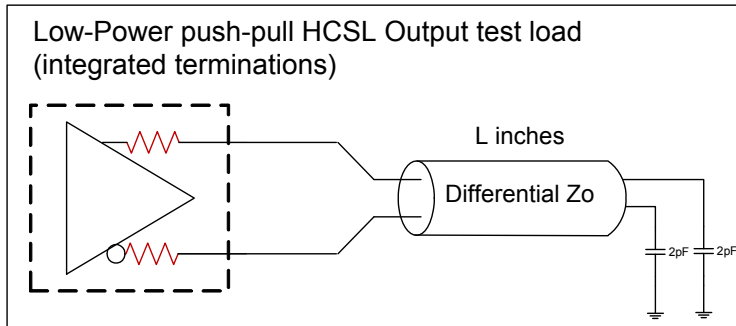

Terminations

Device	Zo (Ω)	Rs (Ω)
9DBL0841	100	None needed
9DBL0851	100	7.5
9DBL08P1	100	Prog.
9DBL0841	85	N/A
9DBL0851	85	None needed
9DBL08P1	85	Prog.

Alternate Terminations

The 9DBL family can easily drive LVPECL, LVDS, and CML logic. See [“AN-891 Driving LVPECL, LVDS, and CML Logic with IDT's "Universal" Low-Power HCSL Outputs”](#) for details.

Absolute Maximum Ratings

Stresses above the ratings listed below can cause permanent damage to the 9DBL08. These ratings, which are standard values for IDT commercially rated parts, are stress ratings only. Functional operation of the device at these or any other conditions above those indicated in the operational sections of the specifications is not implied. Exposure to absolute maximum rating conditions for extended periods can affect product reliability. Electrical parameters are guaranteed only over the recommended operating temperature range.

PARAMETER	SYMBOL	CONDITIONS	MIN	TYP	MAX	UNITS	NOTES
Supply Voltage	VDDx				4.6	V	1,2
Input Voltage	V _{IN}		-0.5		V _{DD} +0.5	V	1,3
Input High Voltage, SMBus	V _{IHSMB}	SMBus clock and data pins			3.9	V	1
Storage Temperature	T _s		-65		150	°C	1
Junction Temperature	T _j				125	°C	1
Input ESD protection	ESD prot	Human Body Model	2500			V	1

¹Guaranteed by design and characterization, not 100% tested in production.

²Operation under these conditions is neither implied nor guaranteed.

³Not to exceed 4.6V.

Electrical Characteristics–SMBus Parameters

TA = T_{AMB}, Supply Voltages per normal operation conditions, See Test Loads for Loading Conditions

PARAMETER	SYMBOL	CONDITIONS	MIN	TYP	MAX	UNITS	NOTES
SMBus Input Low Voltage	V _{ILSMB}	V _{DDSMB} = 3.3V			0.8	V	
SMBus Input High Voltage	V _{IHSMB}	V _{DDSMB} = 3.3V	2.1		3.6	V	
SMBus Output Low Voltage	V _{OLSMB}	@ I _{PULLUP}			0.4	V	
SMBus Sink Current	I _{PULLUP}	@ V _{OL}	4			mA	
Nominal Bus Voltage	V _{DDSMB}		2.7		3.6	V	
SCLK/SDATA Rise Time	t _{RSMB}	(Max VIL - 0.15) to (Min VIH + 0.15)			1000	ns	1
SCLK/SDATA Fall Time	t _{FSMB}	(Min VIH + 0.15) to (Max VIL - 0.15)			300	ns	1
SMBus Operating Frequency	f _{SMB}	SMBus operating frequency			500	kHz	2,3

¹Guaranteed by design and characterization, not 100% tested in production.

²The device must be powered up for the SMBus to function.

³The differential input clock must be running for the SMBus to be active

Electrical Characteristics–Clock Input Parameters

TA = T_{AMB}, Supply Voltages per normal operation conditions, See Test Loads for Loading Conditions

PARAMETER	SYMBOL	CONDITIONS	MIN	TYP	MAX	UNITS	NOTES
Input Crossover Voltage - DIF_IN	V _{CROSS}	Cross Over Voltage	150		900	mV	1
Input Swing - DIF_IN	V _{SWING}	Differential value	300			mV	1
Input Slew Rate - DIF_IN	dv/dt	Measured differentially	0.4		8	V/ns	1,2
Input Leakage Current	I _{IN}	V _{IN} = V _{DD} , V _{IN} = GND	-5		5	uA	
Input Duty Cycle	d _{tin}	Measurement from differential waveform	45		55	%	1
Input Jitter - Cycle to Cycle	J _{DIFIn}	Differential Measurement	0		125	ps	1

¹Guaranteed by design and characterization, not 100% tested in production.

²Slew rate measured through +/-75mV window centered around differential zero

Electrical Characteristics–Input/Supply/Common Parameters–Normal Operating Conditions

$T_A = T_{AMB}$, Supply Voltages per normal operation conditions, See Test Loads for Loading Conditions

PARAMETER	SYMBOL	CONDITIONS	MIN	TYP	MAX	UNITS	NOTES
Supply Voltage	VDDx	Supply voltage for core and analog	3.135	3.3	3.465	V	
Output Supply Voltage	VDDIO	Supply voltage for Low Power HCSSL Outputs	0.95	1.05-3.3	3.465	V	
Ambient Operating Temperature	T_{AMB}	Industrial range	-40	25	85	°C	
Input High Voltage	V_{IH}	Single-ended inputs, except SMBus	$0.75 V_{DDx}$		$V_{DDx} + 0.3$	V	
Input Low Voltage	V_{IL}		-0.3		$0.25 V_{DDx}$	V	
Input High Voltage	V_{IHtri}	Single-ended tri-level inputs ('_tri' suffix)	$0.75 V_{DDx}$		$V_{DD} + 0.3$	V	
Input Mid Voltage	V_{IMtri}		$0.4 V_{DDx}$	$0.5 V_{DDx}$	$0.6 V_{DDx}$	V	
Input Low Voltage	V_{ILtri}		-0.3		$0.25 V_{DDx}$	V	
Input Current	I_{IN}	Single-ended inputs, $V_{IN} = GND$, $V_{IN} = VDD$	-5		5	uA	
	I_{INP}	Single-ended inputs $V_{IN} = 0 V$; Inputs with internal pull-up resistors $V_{IN} = VDD$; Inputs with internal pull-down resistors	-50		50	uA	
Input Frequency	F_{IN}	Bypass mode	1		200	MHz	2
		100MHz PLL mode	60	100.00	140	MHz	2
		50MHz PLL mode	30	50.00	65	MHz	2
		125MHz PLL mode	75	125.00	175	MHz	2
Pin Inductance	L_{pin}			7	nH	1	
Capacitance	C_{IN}	Logic Inputs, except DIF_IN	1.5		5	pF	1
	C_{INDIF_IN}	DIF_IN differential clock inputs	1.5		2.7	pF	1
	C_{OUT}	Output pin capacitance			6	pF	1
Clk Stabilization	T_{STAB}	From V_{DD} Power-Up and after input clock stabilization or de-assertion of PD# to 1st clock			1	ms	1,2
Input SS Modulation Frequency PCIe	$f_{MODINPCIe}$	Allowable Frequency for PCIe Applications (Triangular Modulation)	30		33	kHz	
Input SS Modulation Frequency non-PCIe	f_{MODIN}	Allowable Frequency for non-PCIe Applications (Triangular Modulation)	0		66	kHz	
OE# Latency	$t_{LATOE\#}$	DIF start after OE# assertion DIF stop after OE# deassertion	1		3	clocks	1,3
Tdrive_PD#	t_{DRVPD}	DIF output enable after PD# de-assertion			300	us	1,3
Tfall	t_F	Fall time of single-ended control inputs			5	ns	2
Trise	t_R	Rise time of single-ended control inputs			5	ns	2

¹Guaranteed by design and characterization, not 100% tested in production.

²Control input must be monotonic from 20% to 80% of input swing.

³Time from deassertion until outputs are >200 mV

Electrical Characteristics–DIF Low-Power HCSL Outputs

TA = T_{AMB}, Supply Voltages per normal operation conditions, See Test Loads for Loading Conditions

PARAMETER	SYMBOL	CONDITIONS	MIN	TYP	MAX	UNITS	NOTES
Slew rate	dV/dt	Scope averaging on, fast setting	2	2.8	4	V/ns	1,2,3
	dV/dt	Scope averaging on, slow setting	1.2	1.9	3.1	V/ns	1,2,3
Slew rate matching	Δ dV/dt	Slew rate matching		7	20	%	1,2,4
Voltage High	V _{HIGH}	Statistical measurement on single-ended signal using oscilloscope math function. (Scope averaging on)	660	768	850	mV	7
Voltage Low	V _{LOW}		-150	-11	150		7
Max Voltage	V _{max}	Measurement on single ended signal using absolute value. (Scope averaging off)		811	1150	mV	7
Min Voltage	V _{min}		-300	-49			7
Crossing Voltage (abs)	V _{cross_abs}	Scope averaging off	250	357	550	mV	1,5
Crossing Voltage (var)	Δ -V _{cross}	Scope averaging off		14	140	mV	1,6

¹Guaranteed by design and characterization, not 100% tested in production.

² Measured from differential waveform

³ Slew rate is measured through the V_{swing} voltage range centered around differential 0V. This results in a +/-150mV window around differential 0V.

⁴ Matching applies to rising edge rate for Clock and falling edge rate for Clock#. It is measured using a +/-75mV window centered on the average cross point where Clock rising meets Clock# falling. The median cross point is used to calculate the voltage thresholds the oscilloscope is to use for the edge rate calculations.

⁵ V_{cross} is defined as voltage where Clock = Clock# measured on a component test board and only applies to the differential rising edge (i.e. Clock rising and Clock# falling).

⁶ The total variation of all V_{cross} measurements in any particular system. Note that this is a subset of V_{cross_min/max} (V_{cross} absolute) allowed. The intent is to limit V_{cross} induced modulation by setting Δ -V_{cross} to be smaller than V_{cross} absolute.

⁷ At default SMBus settings.

Electrical Characteristics–Current Consumption

TA = T_{AMB}, Supply Voltages per normal operation conditions, See Test Loads for Loading Conditions

PARAMETER	SYMBOL	CONDITIONS	MIN	TYP	MAX	UNITS	NOTES
Operating Supply Current	I _{DDA}	VDDA, PLL Mode, @100MHz		7	10	mA	
	I _{DD}	VDDx, All outputs active @100MHz		22	32	mA	
	I _{DDIO}	VDDIO, All outputs active @100MHz		35	45	mA	
Powerdown Current	I _{DDAPD}	VDDA, CKPWRGD_PD#=0		0.6	1	mA	2
	I _{DDPD}	VDDx, CKPWRGD_PD#=0		4.9	7	mA	2
	I _{DDIOPD}	VDDIO, CKPWRGD_PD#=0		0.04	0.10	mA	2

¹ Guaranteed by design and characterization, not 100% tested in production.

² Input clock stopped.

Electrical Characteristics–Output Duty Cycle, Jitter, Skew and PLL Characteristics

TA = T_{AMB}, Supply Voltages per normal operation conditions, See Test Loads for Loading Conditions

PARAMETER	SYMBOL	CONDITIONS	MIN	TYP	MAX	UNITS	NOTES
PLL Bandwidth	BW	-3dB point in High BW Mode (100MHz)	2	3.3	4	MHz	1,5
		-3dB point in Low BW Mode (100MHz)	1	1.5	2	MHz	1,5
PLL Jitter Peaking	t _{JPEAK}	Peak Pass band Gain (100MHz)		0.8	2	dB	1
Duty Cycle	t _{DC}	Measured differentially, PLL Mode	45	50	55	%	1
Duty Cycle Distortion	t _{DCD}	Measured differentially, Bypass Mode	-1	0.0	1	%	1,3
Skew, Input to Output	t _{pdBYP}	Bypass Mode, V _T = 50%	2500	3406	4500	ps	1
	t _{pdPLL}	PLL Mode V _T = 50%	-100	8	100	ps	1,4
Skew, Output to Output	t _{sk3}	V _T = 50%		21	55	ps	1,4
		PLL mode		15	50	ps	1,2
Jitter, Cycle to cycle	t _{jycyc-cyc}	Additive Jitter in Bypass Mode		0.1	1	ps	1,2

¹ Guaranteed by design and characterization, not 100% tested in production.

² Measured from differential waveform

³ Duty cycle distortion is the difference in duty cycle between the output and the input clock when the device is operated in bypass mode.

⁴ All outputs at default slew rate

⁵ The MIN/TYP/MAX values of each BW setting track each other, i.e., Low BW MAX will never occur with Hi BW MIN.

Electrical Characteristics–Filtered Phase Jitter Parameters - PCIe Common Clocked (CC) Architectures

T_{AMB} = over the specified operating range. Supply Voltages per normal operation conditions, See Test Loads for Loading Conditions

PARAMETER	SYMBOL	CONDITIONS	MIN	TYP	MAX	INDUSTRY LIMIT	UNITS	Notes
Phase Jitter, PLL Mode	t _{jphPCIeG1-CC}	PCIe Gen 1		23	32	86	ps (p-p)	1,2,3,5
	t _{jphPCIeG2-CC}	PCIe Gen 2 Lo Band 10kHz < f < 1.5MHz (PLL BW of 5-16MHz or 8-5MHz, CDR = 5MHz)		0.6	0.8	3	ps (rms)	1,2,5
		PCIe Gen 2 High Band 1.5MHz < f < Nyquist (50MHz) (PLL BW of 5-16MHz or 8-5MHz, CDR = 5MHz)		1.7	2.1	3.1	ps (rms)	1,2,5
	t _{jphPCIeG3-CC}	PCIe Gen 3 (PLL BW of 2-4MHz or 2-5MHz, CDR = 10MHz)		0.4	0.48	1	ps (rms)	1,2,5
	t _{jphPCIeG4-CC}	PCIe Gen 4 (PLL BW of 2-4MHz or 2-5MHz, CDR = 10MHz)		0.4	0.48	0.5	ps (rms)	1,2,5
Additive Phase Jitter, Bypass mode	t _{jphPCIeG1-CC}	PCIe Gen 1		0.0	0.01	n/a	ps (p-p)	1,2,5
	t _{jphPCIeG2-CC}	PCIe Gen 2 Lo Band 10kHz < f < 1.5MHz (PLL BW of 5-16MHz or 8-5MHz, CDR = 5MHz)		0.0	0.01		ps (rms)	1,2,4,5
		PCIe Gen 2 High Band 1.5MHz < f < Nyquist (50MHz) (PLL BW of 5-16MHz or 8-5MHz, CDR = 5MHz)		0.0	0.01		ps (rms)	1,2,4,5
	t _{jphPCIeG3-CC}	PCIe Gen 3 (PLL BW of 2-4MHz or 2-5MHz, CDR = 10MHz)		0.0	0.01		ps (rms)	1,2,4,5
	t _{jphPCIeG4-CC}	PCIe Gen 4 (PLL BW of 2-4MHz or 2-5MHz, CDR = 10MHz)		0.0	0.01		ps (rms)	1,2,4,5

¹ Applies to all outputs.

² Based on PCIe Base Specification Rev4.0 version 0.7draft. See <http://www.pcisig.com> for latest specifications.

³ Sample size of at least 100K cycles. This figures extrapolates to 108ps pk-pk @ 1M cycles for a BER of 1-12.

⁴ For RMS values additive jitter is calculated by solving the following equation for b [$a^2+b^2=c^2$] where a is rms input jitter and c is rms total jitter.

⁵ Driven by 9FGL0841 or equivalent

Electrical Characteristics—Filtered Phase Jitter Parameters - PCIe Separate Reference Independent Spread (SRIS) Architectures⁵

T_{AMB} = over the specified operating range. Supply Voltages per normal operation conditions, See Test Loads for Loading Conditions

PARAMETER	SYMBOL	CONDITIONS	MIN	TYP	MAX	INDUSTRY LIMIT	UNITS	Notes
Phase Jitter, PLL Mode	t _{jphPCIeG2-SRIS}	PCIe Gen 2 (PLL BW of 16MHz , CDR = 5MHz)		1.2	1.5	2	ps (rms)	1,2
	t _{jphPCIeG3-SRIS}	PCIe Gen 3 (PLL BW of 2-4MHz or 2-5MHz, CDR = 10MHz)		n/a		0.5	ps (rms)	1,2,6
Additive Phase Jitter, Bypass mode	t _{jphPCIeG2-SRIS}	PCIe Gen 2 (PLL BW of 16MHz , CDR = 5MHz)		0.0	0.01	n/a	ps (rms)	1,2,4
	t _{jphPCIeG3-SRIS}	PCIe Gen 3 (PLL BW of 2-4MHz or 2-5MHz, CDR = 10MHz)		0.0	0.01		ps (rms)	1,2,4,6

¹ Applies to all outputs.

² Based on PCIe Base Specification Rev3.1a. These filters are different than Common Clock filters. See <http://www.pcisig.com> for latest specifications.

³ Sample size of at least 100K cycles. This figures extrapolates to 108ps pk-pk @ 1M cycles for a BER of 1-12.

⁴ For RMS values, additive jitter is calculated by solving the following equation for b [$a^2+b^2=c^2$] where a is rms input jitter and c is rms total jitter.

⁵ As of PCIe Base Specification Rev4.0 draft 0.7, SRIS is not currently defined for Gen1 or Gen4.

⁶ This device does not support PCIe Gen3 SRIS in PLL mode. It supports PCIe Gen3 SRIS in bypass mode.

Electrical Characteristics—Unfiltered Phase Jitter Parameters

T_A = T_{AMB}, Supply Voltages per normal operation conditions, See Test Loads for Loading Conditions

PARAMETER	SYMBOL	CONDITIONS	MIN	TYP	MAX	INDUSTRY LIMIT	UNITS	Notes
Additive Phase Jitter, Fanout Mode	t _{jph156M}	156.25MHz, 1.5MHz to 10MHz, -20dB/decade rollover < 1.5MHz, -40db/decade rolloff > 10MHz		159		N/A	fs (rms)	1,2,3
	t _{jph156M12k-20}	156.25MHz, 12kHz to 20MHz, -20dB/decade rollover <12kHz, -40db/decade rolloff > 20MHz		363		N/A	fs (rms)	1,2,3

¹ Guaranteed by design and characterization, not 100% tested in production.

² DRiven by Rohde&Schartz SMA100

³ For RMS figures, additive jitter is calculated by solving the following equation: Additive jitter = SQRT[(total jitter)² - (input jitter)²]

General SMBus Serial Interface Information

How to Write

- Controller (host) sends a start bit
- Controller (host) sends the write address
- IDT clock will **acknowledge**
- Controller (host) sends the beginning byte location = N
- IDT clock will **acknowledge**
- Controller (host) sends the byte count = X
- IDT clock will **acknowledge**
- Controller (host) starts sending Byte N through Byte N+X-1
- IDT clock will **acknowledge** each byte **one at a time**
- Controller (host) sends a Stop bit

Index Block Write Operation			
Controller (Host)			IDT (Slave/Receiver)
T	starT bit		
Slave Address			
WR	WRite		
			ACK
Beginning Byte = N			
			ACK
Data Byte Count = X			
			ACK
Beginning Byte N		X Byte	
O			ACK
O			O
O			O
O			O
Byte N + X - 1			
			ACK
P	stoP bit		

Note: SMBus Address is Latched on SADR pin. Unless otherwise indicated, default values are for the xx31, xx41, and xx51. P1 devices are fully factory programmable.

How to Read

- Controller (host) will send a start bit
- Controller (host) sends the write address
- IDT clock will **acknowledge**
- Controller (host) sends the beginning byte location = N
- IDT clock will **acknowledge**
- Controller (host) will send a separate start bit
- Controller (host) sends the read address
- IDT clock will **acknowledge**
- IDT clock will send the data byte count = X
- IDT clock sends Byte N+X-1
- IDT clock sends **Byte 0 through Byte X (if X_(H) was written to Byte 8)**
- Controller (host) will need to acknowledge each byte
- Controller (host) will send a not acknowledge bit
- Controller (host) will send a stop bit

Index Block Read Operation			
Controller (Host)			IDT (Slave/Receiver)
T	starT bit		
Slave Address			
WR	WRite		
			ACK
Beginning Byte = N			
			ACK
RT	Repeat starT		
Slave Address			
RD	ReaD		
			ACK
			Data Byte Count=X
ACK		X Byte	
ACK			Beginning Byte N
			O
			O
			O
			Byte N + X - 1
N	Not acknowledge		
P	stoP bit		

SMBus Table: Output Enable Register ¹

Byte 0	Name	Control Function	Type	0	1	Default
Bit 7	DIF OE7	Output Enable	RW	See B11[1:0]	Pin Control	1
Bit 6	DIF OE6	Output Enable	RW		Pin Control	1
Bit 5	DIF OE5	Output Enable	RW		Pin Control	1
Bit 4	DIF OE4	Output Enable	RW		Pin Control	1
Bit 3	DIF OE3	Output Enable	RW		Pin Control	1
Bit 2	DIF OE2	Output Enable	RW		Pin Control	1
Bit 1	DIF OE1	Output Enable	RW		Pin Control	1
Bit 0	DIF OE0	Output Enable	RW		Pin Control	1

1. A low on these bits will override the OE# pin and force the differential output to the state indicated by B11[1:0] (Low/Low default)

SMBus Table: PLL Operating Mode and Output Amplitude Control Register

Byte 1	Name	Control Function	Type	0	1	Default
Bit 7	PLLMODERB1	PLL Mode Readback Bit 1	R	See PLL Operating Mode Table		Latch
Bit 6	PLLMODERB0	PLL Mode Readback Bit 0	R			Latch
Bit 5	PLLMODE_SWCNTRL	Enable SW control of PLL Mode	RW	Values in B1[7:6] set PLL Mode	Values in B1[4:3] set PLL Mode	0
Bit 4	PLLMODE1	PLL Mode Control Bit 1	RW ¹	See PLL Operating Mode Table		0
Bit 3	PLLMODE0	PLL Mode Control Bit 0	RW ¹			0
Bit 2	Reserved					1
Bit 1	AMPLITUDE 1	Controls Output Amplitude	RW	00 = 0.6V	01 = 0.68V	1
Bit 0	AMPLITUDE 0		RW	10 = 0.75V	11 = 0.85V	0

1. B1[5] must be set to a 1 for these bits to have any effect on the part.

SMBus Table: DIF Slew Rate Control Register

Byte 2	Name	Control Function	Type	0	1	Default
Bit 7	SLEWRATESEL DIF7	Adjust Slew Rate of DIF7	RW	Slow Setting	Fast Setting	1
Bit 6	SLEWRATESEL DIF6	Adjust Slew Rate of DIF6	RW	Slow Setting	Fast Setting	1
Bit 5	SLEWRATESEL DIF5	Adjust Slew Rate of DIF5	RW	Slow Setting	Fast Setting	1
Bit 4	SLEWRATESEL DIF4	Adjust Slew Rate of DIF4	RW	Slow Setting	Fast Setting	1
Bit 3	SLEWRATESEL DIF3	Adjust Slew Rate of DIF3	RW	Slow Setting	Fast Setting	1
Bit 2	SLEWRATESEL DIF2	Adjust Slew Rate of DIF2	RW	Slow Setting	Fast Setting	1
Bit 1	SLEWRATESEL DIF1	Adjust Slew Rate of DIF1	RW	Slow Setting	Fast Setting	1
Bit 0	SLEWRATESEL DIF0	Adjust Slew Rate of DIF0	RW	Slow Setting	Fast Setting	1

Note: See "Low-Power HCSL Outputs" table for slew rates.

SMBus Table: Frequency Select Control Register

Byte 3	Name	Control Function	Type	0	1	Default
Bit 7	Reserved					1
Bit 6	Reserved					1
Bit 5	FREQ_SEL_EN	Enable SW selection of frequency	RW	SW frequency change disabled	SW frequency change enabled	0
Bit 4	FSEL1	Freq. Select Bit 1	RW ¹	00 = 100M, 10 = 125M 01 = 50M, 11 = Reserved		0
Bit 3	FSEL0	Freq. Select Bit 0	RW ¹			0
Bit 2	Reserved					1
Bit 1	Reserved					1
Bit 0	SLEWRATESEL FB	Adjust Slew Rate of FB	RW	Slow Setting	Fast Setting	1

1. B3[5] must be set to a 1 for these bits to have any effect on the part.

Byte 4 is Reserved

SMBus Table: Revision and Vendor ID Register

Byte 5	Name	Control Function	Type	0	1	Default
Bit 7	RID3	Revision ID	R	B rev = 0001		0
Bit 6	RID2		R			0
Bit 5	RID1		R			0
Bit 4	RID0		R			1
Bit 3	VID3	VENDOR ID	R	0001 = IDT		0
Bit 2	VID2		R			0
Bit 1	VID1		R			0
Bit 0	VID0		R			1

SMBus Table: Device Type/Device ID

Byte 6	Name	Control Function	Type	0	1	Default
Bit 7	Device Type1	Device Type	RW	00 = FGx, 01 = DBx ZDB/FOB, 10 = DMx, 11= DBx FOB		0
Bit 6	Device Type0		RW			1
Bit 5	Device ID5	Device ID	RW	001000 binary or 08 hex		0
Bit 4	Device ID4		RW			0
Bit 3	Device ID3		RW			1
Bit 2	Device ID2		RW			0
Bit 1	Device ID1		RW			0
Bit 0	Device ID0		RW			0

SMBus Table: Byte Count Register

Byte 7	Name	Control Function	Type	0	1	Default
Bit 7		Reserved				0
Bit 6		Reserved				0
Bit 5		Reserved				0
Bit 4	BC4	Byte Count Programming	RW	Writing to this register will configure how many bytes will be read back, default is = 8 bytes.		0
Bit 3	BC3		RW			1
Bit 2	BC2		RW			0
Bit 1	BC1		RW			0
Bit 0	BC0		RW			0

Bytes 8 and 9 are Reserved

SMBus Table: PD_Restore

Byte 10	Name	Control Function	Type	0	1	Default
Bit 7		Reserved				1
Bit 6	Power-Down (PD) Restore	Restore Default Config. In PD	RW	Clear Config in PD	Keep Config in PD	1
Bit 5		Reserved				0
Bit 4		Reserved				0
Bit 3		Reserved				0
Bit 2		Reserved				0
Bit 1		Reserved				0
Bit 0		Reserved				0

SMBus Table: Impedance Control

Byte 11	Name	Control Function	Type	0	1	Default
Bit 7	FB_imp[1]	Feedback Zout	RW	00=33→ DIF Zout	10=100→ DIF Zout	see Note
Bit 6	FB_imp[0]		RW	01=85→ DIF Zout	11 = Reserved	
Bit 5		Reserved				0
Bit 4		Reserved				0
Bit 3		Reserved				0
Bit 2		Reserved				0
Bit 1	STP[1]	True/Complement DIF Output	RW	00 = Low/Low	10 = High/Low	0
Bit 0	STP[0]	Disable State	RW	01 = HiZ/HiZ	11 = Low/High	0

Note: xx41 = 10, xx51 = 01, P1 = factory programmable.

SMBus Table: Impedance Control

Byte 12	Name	Control Function	Type	0	1	Default
Bit 7	DIF3_imp[1]	DIF3 Zout	RW	00=33→ DIF Zout	10=100→ DIF Zout	see Note
Bit 6	DIF3_imp[0]	DIF3 Zout	RW	01=85→ DIF Zout	11 = Reserved	
Bit 5	DIF2_imp[1]	DIF2 Zout	RW	00=33→ DIF Zout	10=100→ DIF Zout	
Bit 4	DIF2_imp[0]	DIF2 Zout	RW	01=85→ DIF Zout	11 = Reserved	
Bit 3	DIF1_imp[1]	DIF1 Zout	RW	00=33→ DIF Zout	10=100→ DIF Zout	
Bit 2	DIF1_imp[0]	DIF1 Zout	RW	01=85→ DIF Zout	11 = Reserved	
Bit 1	DIF0_imp[1]	DIF0 Zout	RW	00=33→ DIF Zout	10=100→ DIF Zout	
Bit 0	DIF0_imp[0]	DIF0 Zout	RW	01=85→ DIF Zout	11 = Reserved	

Note: xx41 = 10, xx51 = 01, P1 = factory programmable.

SMBus Table: Impedance Control

Byte 13	Name	Control Function	Type	0	1	Default
Bit 7	DIF7_imp[1]	DIF7 Zout	RW	00=33→ DIF Zout	10=100→ DIF Zout	see Note
Bit 6	DIF7_imp[0]	DIF7 Zout	RW	01=85→ DIF Zout	11 = Reserved	
Bit 5	DIF6_imp[1]	DIF6 Zout	RW	00=33→ DIF Zout	10=100→ DIF Zout	
Bit 4	DIF6_imp[0]	DIF6 Zout	RW	01=85→ DIF Zout	11 = Reserved	
Bit 3	DIF5_imp[1]	DIF5 Zout	RW	00=33→ DIF Zout	10=100→ DIF Zout	
Bit 2	DIF5_imp[0]	DIF5 Zout	RW	01=85→ DIF Zout	11 = Reserved	
Bit 1	DIF4_imp[1]	DIF4 Zout	RW	00=33→ DIF Zout	10=100→ DIF Zout	
Bit 0	DIF4_imp[0]	DIF4 Zout	RW	01=85→ DIF Zout	11 = Reserved	

Note: xx41 = 10, xx51 = 01, P1 = factory programmable.

SMBus Table: Pull-up Pull-down Control

Byte 14	Name	Control Function	Type	0	1	Default
Bit 7	OE3_pu/pd[1]	OE3 Pull-up(PuP)/	RW	00=None	10=Pup	0
Bit 6	OE3_pu/pd[0]	Pull-down(Pdwn) control	RW	01=Pdwn	11 = Pup+Pdwn	1
Bit 5	OE2_pu/pd[1]	OE2 Pull-up(PuP)/	RW	00=None	10=Pup	0
Bit 4	OE2_pu/pd[0]	Pull-down(Pdwn) control	RW	01=Pdwn	11 = Pup+Pdwn	1
Bit 3	OE1_pu/pd[1]	OE1 Pull-up(PuP)/	RW	00=None	10=Pup	0
Bit 2	OE1_pu/pd[0]	Pull-down(Pdwn) control	RW	01=Pdwn	11 = Pup+Pdwn	1
Bit 1	OE0_pu/pd[1]	OE0 Pull-up(PuP)/	RW	00=None	10=Pup	0
Bit 0	OE0_pu/pd[0]	Pull-down(Pdwn) control	RW	01=Pdwn	11 = Pup+Pdwn	1

Note: These values are for xx41 and xx51. P1 is factory programmable.

Byte 15	Name	Control Function	Type	0	1	Default
Bit 7	OE7_pu/pd[1]	OE7 Pull-up(PuP)/	RW	00=None	10=Pup	0
Bit 6	OE7_pu/pd[0]	Pull-down(Pdwn) control	RW	01=Pdwn	11 = Pup+Pdwn	1
Bit 5	OE6_pu/pd[1]	OE6 Pull-up(PuP)/	RW	00=None	10=Pup	0
Bit 4	OE6_pu/pd[0]	Pull-down(Pdwn) control	RW	01=Pdwn	11 = Pup+Pdwn	1
Bit 3	OE5_pu/pd[1]	OE5 Pull-up(PuP)/	RW	00=None	10=Pup	0
Bit 2	OE5_pu/pd[0]	Pull-down(Pdwn) control	RW	01=Pdwn	11 = Pup+Pdwn	1
Bit 1	OE4_pu/pd[1]	OE4 Pull-up(PuP)/	RW	00=None	10=Pup	0
Bit 0	OE4_pu/pd[0]	Pull-down(Pdwn) control	RW	01=Pdwn	11 = Pup+Pdwn	1

Note: These values are for xx41 and xx51. P1 is factory programmable.

SMBus Table: Pull-up Pull-down Control

Byte 16	Name	Control Function	Type	0	1	Default
Bit 7		Reserved				0
Bit 6		Reserved				0
Bit 5		Reserved				0
Bit 4		Reserved				0
Bit 3		Reserved				0
Bit 2		Reserved				0
Bit 1	CKPWRGD_PD_pu/pd[1]	CKPWRGD_PD Pull-up(PuP)/	RW	00=None	10=Pup	1
Bit 0	CKPWRGD_PD_pu/pd[0]	Pull-down(Pdwn) control	RW	01=Pdwn	11 = Pup+Pdwn	0

Note: These values are for xx41 and xx51. P1 is factory programmable.

Bytes 17 is Reserved and reads back 0h00.

SMBus Table: Polarity Control

Byte 18	Name	Control Function	Type	0	1	Default
Bit 7	OE7_polarity	Sets OE7 polarity	RW	Enabled when Low	Enabled when High	0
Bit 6	OE6_polarity	Sets OE6 polarity	RW	Enabled when Low	Enabled when High	0
Bit 5	OE5_polarity	Sets OE5 polarity	RW	Enabled when Low	Enabled when High	0
Bit 4	OE4_polarity	Sets OE4 polarity	RW	Enabled when Low	Enabled when High	0
Bit 3	OE3_polarity	Sets OE3 polarity	RW	Enabled when Low	Enabled when High	0
Bit 2	OE2_polarity	Sets OE2 polarity	RW	Enabled when Low	Enabled when High	0
Bit 1	OE1_polarity	Sets OE1 polarity	RW	Enabled when Low	Enabled when High	0
Bit 0	OE0_polarity	Sets OE0 polarity	RW	Enabled when Low	Enabled when High	0

SMBus Table: Polarity Control

Byte 19	Name	Control Function	Type	0	1	Default
Bit 7		Reserved				0
Bit 6		Reserved				0
Bit 5		Reserved				0
Bit 4		Reserved				0
Bit 3		Reserved				0
Bit 2		Reserved				0
Bit 1		Reserved				0
Bit 0	CKPWRGD_PD	Determines CKPWRGD_PD polarity	RW	Power Down when Low	Power Down when High	0

Marking Diagrams

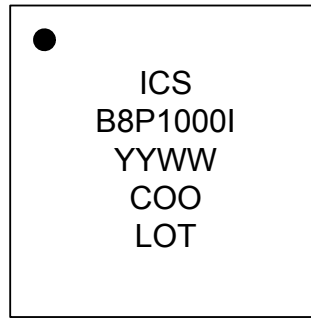
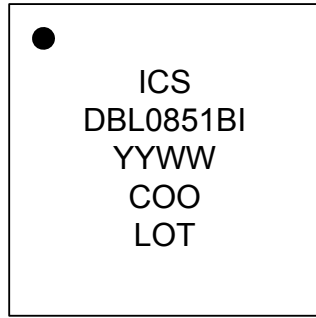
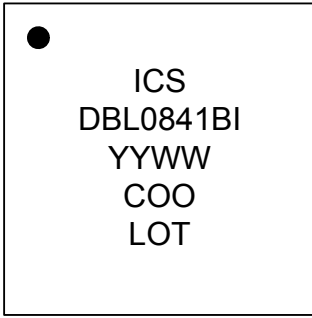

Notes:

1. "LOT" is the lot sequence number.
2. "COO" denotes country of origin.
3. YYWW is the last two digits of the year and week that the part was assembled.
4. Line 2: truncated part number
5. "L" denotes RoHS compliant package.
6. "I" denotes industrial temperature range device.

Thermal Characteristics

PARAMETER	SYMBOL	CONDITIONS	PKG	TYP VALUE	UNITS	NOTES
Thermal Resistance	θ_{JC}	Junction to Case	NDG48	33	°C/W	1
	θ_{Jb}	Junction to Base		2.1	°C/W	1
	θ_{JA00}	Junction to Air, still air		37	°C/W	1
	θ_{JA1}	Junction to Air, 1 m/s air flow		30	°C/W	1
	θ_{JA3}	Junction to Air, 3 m/s air flow		27	°C/W	1
	θ_{JA5}	Junction to Air, 5 m/s air flow		26	°C/W	1

¹ePad soldered to board

Package Outline and Dimensions (NDG48). Use Option 1.

REVISIONS			
REV	DESCRIPTION	DATE	APPROVED
00	INITIAL RELEASE	01/10/08	DP
01	UPDATE EXPOSED PAD ADD TABLE	08/05/10	DP
02	COMBINE POD & LAND PATTERN	10/29/13	J.HUA
03	ADD NOTE RECOMMENDED LAND PATTERN	8/31/15	J.HUA

TOP VIEW

SIDE VIEW

BOTTOM VIEW

OPTION 1:

SYMBOL	DIMENSION		
	MIN	NOM	MAX
D2	3.95	4.10	4.20
E2	3.95	4.10	4.20
L	0.30	0.40	0.50
K	0.55 REF		
D	6.00 BSC		
E	6.00 BSC		
e	0.40 BSC		
A	0.80	0.90	1.00
A1	0.00	0.02	0.05
A3	---	0.20 REF	---
N	48		
ND	12		
NE	12		
b	0.15	0.20	0.25

OPTION 2:

SYMBOL	DIMENSION		
	MIN	NOM	MAX
D2	4.10	4.20	4.30
E2	4.10	4.20	4.30
L	0.35	0.40	0.45
K	0.50 REF		

TOLERANCES UNLESS SPECIFIED

DECIMAL	ANGULAR
±0.1	±1°
±0.2	±1°
±0.3	±1°
±0.4	±1°
±0.5	±1°

APPROVALS

DATE	DATE
01/11/08	

CHECKED

SIZE	DRAWING No.	REV
C	PSC-4212	0.3

IDT™

6024 Silver Creek Valley Road
San Jose CA 95138
PHONE: (408) 284-8200
WWW.IDT.COM
FAX: (408) 284-8591

TITLE: ND/NDG 48 PACKAGE OUTLINE
6.0 x 6.0 mm BODY
0.40 mm PITCH VFQFN

DO NOT SCALE DRAWING

SHEET 1 OF 2

NOTES:

- ALL DIMENSIONING AND TOLERANCING CONFORM TO ANSI Y14.5M-1982
- ALL DIMENSIONS ARE IN MILLIMETERS
- N REFERS TO THE NUMBER OF LEADS
- ND AND NE REFER TO THE NUMBER OF LEADS PER SIDE.

Package Outline and Dimensions (NDG48), cont. Use Option 1 EPAD

REVISIONS			
REV	DESCRIPTION	DATE	APPROVED
00	INITIAL RELEASE	01/10/08	DP
01	UPDATE EXPOSED PAD ADD TABLE	08/05/10	DP
02	COMBINE PAD & LAND PATTERN	10/29/13	J.HUA
03	ADD NOTE RECOMMENDED LAND PATTERN	8/31/15	J.HUA

OPTION 1 EPAD (4.20 mm)

OPTION 2 EPAD (4.30 mm)

RECOMMENDED LAND PATTERN DIMENSION

NOTES:

1. ALL DIMENSION ARE IN mm. ANGLES IN DEGREES.
2. TOP DOWN VIEW, AS VIEWED ON PCB.
3. COMPONENT OUTLINE SHOW FOR REFERENCE IN GREEN.
4. LAND PATTERN IN BLUE. NSMD PATTERN ASSUMED.
5. LAND PATTERN RECOMMENDATION PER IPC-7351B GENERIC REQUIREMENT FOR SURFACE MOUNT DESIGN AND LAND PATTERN.

		6024 Silver Creek Valley Road San Jose CA 95138 PHONE: (408) 284-8200 WWW.IDT.COM FAX: (408) 284-8591	
TOLERANCES UNLESS SPECIFIED DECIMAL ANGULAR X.X ±0.1° X.XX ±0.05° X.XX ±0.025°		TITLE ND/NDG 48 PACKAGE OUTLINE 6.0 x 6.0 mm BODY 0.40 mm PITCH VFQFN	
APPROVALS	DATE	SIZE	REV
DRAWN	01/11/08	C	03
CHECKED		PSC-4212	
DO NOT SCALE DRAWING			SHEET 2 OF 2

Ordering Information

Part / Order Number	Notes	Shipping Packaging	Package	Temperature
9DBL0841BKILF	100Ω	Trays	48-pin VFQFPN	-40 to +85° C
9DBL0841BKILFT		Tape and Reel	48-pin VFQFPN	-40 to +85° C
9DBL0851BKILF	85Ω	Trays	48-pin VFQFPN	-40 to +85° C
9DBL0851BKILFT		Tape and Reel	48-pin VFQFPN	-40 to +85° C
9DBL08P1BxxxKILF	Factory configurable. Contact IDT for additional information.	Trays	48-pin VFQFPN	-40 to +85° C
9DBL08P1BxxxKILFT		Tape and Reel	48-pin VFQFPN	-40 to +85° C

“LF” suffix to the part number are the Pb-Free configuration and are RoHS compliant.

“B” is the device revision designator (will not correlate with the datasheet revision).

“xxx” is a unique factory assigned number to identify a particular default configuration.

Revision History

Rev.	Initiator	Issue Date	Description	Page #
A	RDW	5/31/2016	<ol style="list-style-type: none"> 1. Add PCIe G1-4 Common Clock and PCIe SRIS to electrical tables 2. Update Electrical Tables to final 3. Changed '1' value in Byte 0 to indicate "Pin Control" 4. Stylistic update to block diagram 5. Minor updates to SMBus registers 0 and 1 for Readability 6. Front page text update for family consistency. 7. Removed '000' code from ordering information, updated table. 8. Updated SMBus Byte 1[1:0] description 9. Update SMBUS Byte 11[1:0] description 	Various
B	RDW	6/14/2016	<ol style="list-style-type: none"> 1. Electrical Table and SMBus Updates/Corrections 2. SMBus operating frequency is now set to 500KHz max. 3. Removed duplicate Absolute Maximum Table. 4. Release to final. 	Various
C	RDW	6/21/2016	<ol style="list-style-type: none"> 1. Max SMBus freq changed from 400kHz to 500kHz. 2. Page 13. Byte 11[7:6] are now renamed.. 3. Page 14. Byte 16 - Bits 3 and 2 are now reserved. References to 9DBL09xx devices in footnote removed. 4. Page 14. Byte 19 - Bit 1 is reserved 	5,13,14
D	RDW	8/16/2016	Corrected typo in part number under Output Features.	1



Corporate Headquarters
6024 Silver Creek Valley Road
San Jose, CA 95138 USA
www.IDT.com

Sales
1-800-345-7015 or 408-284-8200
Fax: 408-284-2775
www.IDT.com/go/sales

Tech Support
www.idt.com/go/support

DISCLAIMER Integrated Device Technology, Inc. (IDT) and its subsidiaries reserve the right to modify the products and/or specifications described herein at any time and at IDT's sole discretion. All information in this document, including descriptions of product features and performance, is subject to change without notice. Performance specifications and the operating parameters of the described products are determined in the independent state and are not guaranteed to perform the same way when installed in customer products. The information contained herein is provided without representation or warranty of any kind, whether express or implied, including, but not limited to, the suitability of IDT's products for any particular purpose, an implied warranty of merchantability, or non-infringement of the intellectual property rights of others. This document is presented only as a guide and does not convey any license under intellectual property rights of IDT or any third parties.

IDT's products are not intended for use in applications involving extreme environmental conditions or in life support systems or similar devices where the failure or malfunction of an IDT product can be reasonably expected to significantly affect the health or safety of users. Anyone using an IDT product in such a manner does so at their own risk, absent an express, written agreement by IDT.

Integrated Device Technology, IDT and the IDT logo are registered trademarks of IDT. Product specification subject to change without notice. Other trademarks and service marks used herein, including protected names, logos and designs, are the property of IDT or their respective third party owners.

Copyright ©2016 Integrated Device Technology, Inc.. All rights reserved.