

# Digital Output

## FB6213BR



- 4-channel
- Outputs Ex ia
- Installation in suitable enclosures in Zone 1
- Module can be exchanged under voltage (hot swap)
- Line fault detection (LFD)
- Positive or negative logic selectable
- Simulation mode for service operations (forcing)
- Permanently self-monitoring
- Output with watchdog



### Function

The digital output features 4 independent channels.  
 The device can be used to drive solenoids, sounders, or LEDs.  
 Open and short-circuit line faults are detected.  
 The outputs are galvanically isolated from the bus and the power supply.

### Connection

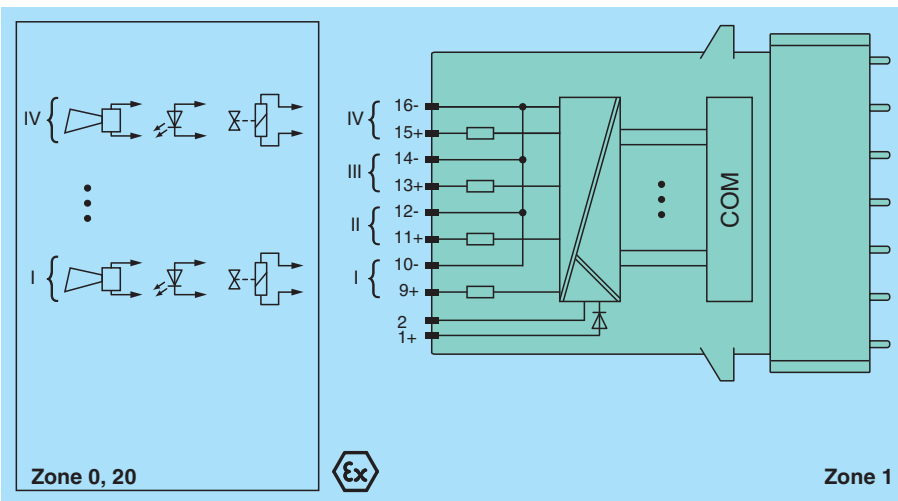

### Technical Data

<b>Slots</b>	
Occupied slots	2
<b>Supply</b>	
Connection	backplane bus / 24 V booster via wire ends
Rated voltage	U <sub>r</sub> 12 V DC , only in connection with the power supplies FB92**
Input voltage range	U 18.5 ... 32 V DC (SELV/PELV) booster voltage
Power dissipation	3 W
Power consumption	0.15 W
<b>Internal bus</b>	
Connection	backplane bus
Interface	manufacturer-specific bus to standard com unit

Release date: 2020-04-30 Date of issue: 2020-04-30 Filename: 276340\_eng.pdf

Refer to "General Notes Relating to Pepperl+Fuchs Product Information".

Pepperl+Fuchs Group  
 www.pepperl-fuchs.com

USA: +1 330 486 0002  
 pa-info@us.pepperl-fuchs.com

Germany: +49 621 776 2222  
 pa-info@de.pepperl-fuchs.com

Singapore: +65 6779 9091  
 pa-info@sg.pepperl-fuchs.com

**PF** PEPPERL+FUCHS

## Technical Data

Digital output		
Number of channels		4
Suitable field devices		
Field device		Solenoid Valve
Field device [2]		audible alarm
Field device [3]		visual alarm
Connection		channel I: 9+, 10-; channel II: 11+, 12-; channel III: 13+, 14-; channel IV: 15+, 16-
Current limit	$I_{max}$	42 mA
Internal resistor	$R_i$	max. 290 $\Omega$
Open loop voltage		23 V
Line fault detection		can be switched on/off for each channel via configuration tool also when turned off (every 2.5 s the valve is turned on for 2 ms)
Short-circuit		< 100 $\Omega$
Open-circuit		> 15 k $\Omega$
Response time		10 ms (depending on bus cycle time)
Watchdog		within 0.5 s the device goes in safe state, e.g. after loss of communication
Reaction time		10 s
Indicators/settings		
LED indication		LED green: supply LED red: line fault , red flashing: communication error
Coding		optional mechanical coding via front socket
Directive conformity		
Electromagnetic compatibility		
Directive 2014/30/EU		EN 61326-1
Conformity		
Electromagnetic compatibility		
Degree of protection		NE 21
Environmental test		IEC 60529
Shock resistance		EN 60068-2-14
Vibration resistance		EN 60068-2-27
Damaging gas		EN 60068-2-6
Relative humidity		EN 60068-2-42
		EN 60068-2-56
Ambient conditions		
Ambient temperature		-20 ... 60 °C (-4 ... 140 °F)
Storage temperature		-25 ... 85 °C (-13 ... 185 °F)
Relative humidity		95 % non-condensing
Shock resistance		shock type I, shock duration 11 ms, shock amplitude 15 g, number of shocks 18
Vibration resistance		frequency range 10 ... 150 Hz; transition frequency: 57.56 Hz, amplitude/acceleration $\pm 0.075$ mm/1 g; 10 cycles frequency range 5 ... 100 Hz; transition frequency: 13.2 Hz amplitude/acceleration $\pm 1$ mm/0.7 g; 90 minutes at each resonance
Damaging gas		designed for operation in environmental conditions acc. to ISA-S71.04-1985, severity level G3
Mechanical specifications		
Degree of protection		IP20 (module) , a separate housing is required acc. to the system description
Connection		removable front connector with screw flange (accessory) wiring connection via spring terminals (0.14 ... 1.5 mm <sup>2</sup> ) or screw terminals (0.08 ... 1.5 mm <sup>2</sup> )
Mass		approx. 750 g
Dimensions		57 x 107 x 132 mm (2.2 x 4.2 x 5.2 inch)
Data for application in connection with hazardous areas		
EU-Type Examination Certificate		
Marking		PTB 97 ATEX 1074 U Ⓢ II 2(1) G Ex d [ia Ga] IIC Gb Ⓢ II (1) D [Ex ia Da] IIIC
Output		
Voltage	$U_o$	26 V

Release date: 2020-04-30 Date of issue: 2020-04-30 Filename: 276340\_eng.pdf

**Technical Data**

Current	$I_o$	110 mA
Power	$P_o$	714 mW
Internal capacitance	$C_i$	2.5 nF
Internal inductance	$L_i$	0 mH
Galvanic isolation		
Output/power supply, internal bus		safe electrical isolation acc. to EN 60079-11, voltage peak value 375 V
Directive conformity		
Directive 2014/34/EU		EN 60079-0:2009 EN 60079-1:2007 EN 60079-11:2007 EN 60079-26:2007 EN 61241-11:2006
<b>International approvals</b>		
ATEX approval		PTB 97 ATEX 1075 ; PTB 97 ATEX 1074 U
EAC approval		Russia: RU C-IT.MIII06.B.00129
Marine approval		
Lloyd Register		15/20021
DNV GL Marine		TAA0000034
American Bureau of Shipping		T1450280/UN
Bureau Veritas Marine		22449/B0 BV
<b>General information</b>		
System information		The module has to be mounted in appropriate backplanes and housings (FB92**) in Zone 1, 2, 21, 22 or outside hazardous areas (gas or dust). Here, observe the corresponding EC-type examination certificate.
Supplementary information		EC-Type Examination Certificate, Statement of Conformity, Declaration of Conformity, Attestation of Conformity and instructions have to be observed where applicable. For information see <a href="http://www.pepperl-fuchs.com">www.pepperl-fuchs.com</a> .

**Assembly**

**Front view**

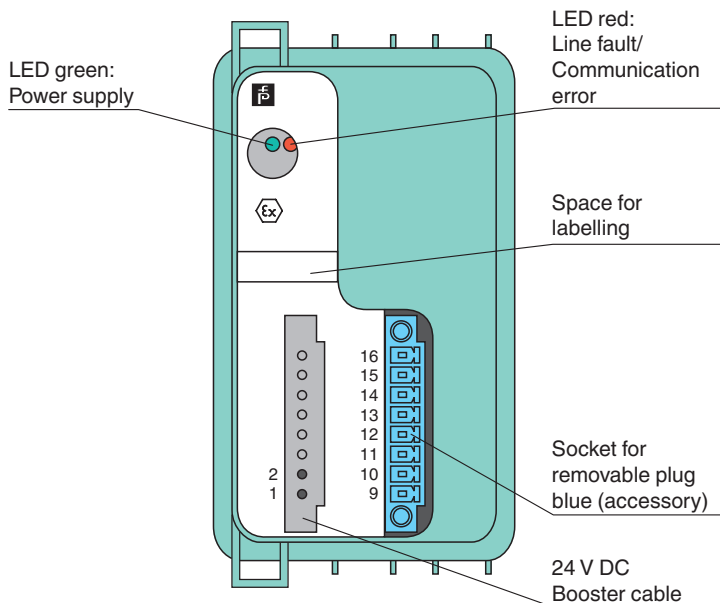

Release date: 2020-04-30 Date of issue: 2020-04-30 Filename: 276340\_eng.pdf

Refer to "General Notes Relating to Pepperl+Fuchs Product Information".

Pepperl+Fuchs Group  
[www.pepperl-fuchs.com](http://www.pepperl-fuchs.com)

USA: +1 330 486 0002  
[pa-info@us.pepperl-fuchs.com](mailto:pa-info@us.pepperl-fuchs.com)

Germany: +49 621 776 2222  
[pa-info@de.pepperl-fuchs.com](mailto:pa-info@de.pepperl-fuchs.com)

Singapore: +65 6779 9091  
[pa-info@sg.pepperl-fuchs.com](mailto:pa-info@sg.pepperl-fuchs.com)

**Characteristic Curve**

**Load calculation**

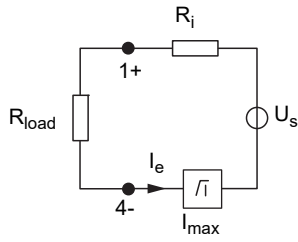

$R_{load}$  = Field loop resistance  
 $U_e = U_s - R_i \times I_e$   
 $I_e = U_s / (R_i + R_{load})$

**Output characteristics**

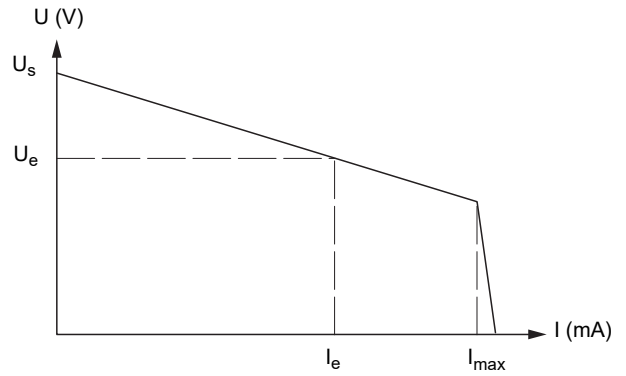

Release date: 2020-04-30 Date of issue: 2020-04-30 Filename: 276340\_eng.pdf