

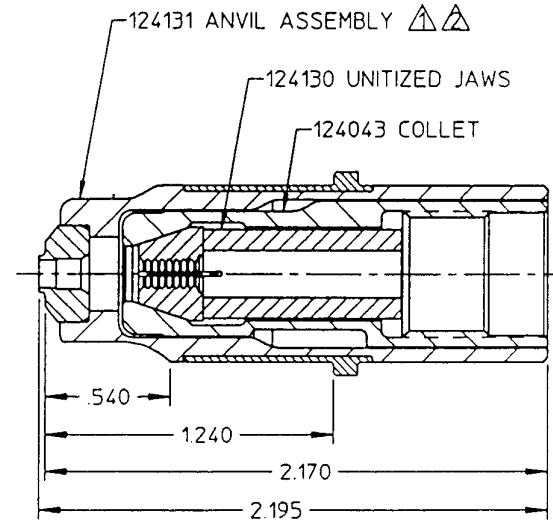

**Huck  
Fasteners**

From Cordant Technologies

# NOSE ASSEMBLY DATA SHEET

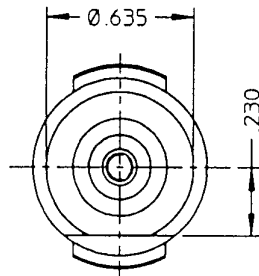

©Huck International, Inc. 1995  
 ©Registered Trademark of Huck International, Inc., Irvine, CA  
 ™Trademark of Huck International, Inc., Irvine, CA

NOTES:

- ⚠ ANVIL ASSEMBLY 124131 CONSISTS OF:  
ANVIL HOLDER ASSEMBLY 123955 AND  
ANVIL INSERT 123795
- ⚠ ANVIL HOLDER ASSEMBLY 123955 CONSISTS OF:  
ANVIL HOLDER 123954, (NOT AVAILABLE SEPARATELY),  
RETAINER 120738.

Gold colored anvil for  
**UNIMATIC® fasteners.**

U.S. Patent No. 4,347,728

<b>99-2730</b>	<b>Huck International, Inc.</b> Installation System Division 1 Corporate Drive - Kingston, NY 12401	
	<b>TYPE:</b> UNIMATIC, Blind Rivet, Short Lgth. <b>FOR:</b> -U05, NAS1919U05; NAS1921U05 <b>TOOL:</b> 202; 212; 230; 352; 2400	
	<b>OTHER</b>	<b>ISSUED:</b> 4-96 <b>REVISED:</b> A

## Nose Assembly Maintenance

1. Prepare tool per manual - - remove any shims from spindle/rod with small pick. Select pintail tube below to prevent small diameter pintails from jamming in pull piston or spindle.

Fastener	200/212/230/352/2400
-04 (1 /8)	100534-1
-05 (5/32)	100534-1
-06 (3/ 16)	None req'd.

**WARNING: Before maintenance or adjustments, POWERIGS Hydraulic Unit must be disconnected from electrical or air supply; air operated tools must be disconnected from air supply. If not disconnected, severe personal injury and/or damage may result.**

### 2. Tools that use hydraulic source:

Connect tool's hoses and controls to unit. Reconnect power source. Depress trigger for 30 seconds. Disconnect controls and RETURN hose. **Tool piston must be completely forward.**

### Tools that use air source:

Air supply should have filter - regulator- lubricator unit with regulator set at 90 psi (620 kPa). See **WARNING** - - cycle tool a few times and disconnect with spindle/rod completely forward.

### 3. Disassembly/assembly as applicable:

Disassemble for inspection and maintenance. **Collet: extension: Stake extension to spindle/rod before attaching collet to extension - - use only one shim. See 6. - - do not stake collet until jaw tension is correct - - see Fig. 1.** SHIM AND LOCK COLLAR ARE NO1- USED ON 200 TOOL SPINDLE - - spacer, 100536, is used instead - - see Fig. 3. SUPER O-LUBE on O-rings and follower. VIBRA-TITE to extension W/O lock collar. See **Caution** above - - thread on collett extension - - use 9/16 collet wrench, wrench flats, 5/32. 3/16, 1 /4 and/or 5/16 hex key and tighten wrench-tight.

**200 Tool:** Hold spanner wrench, 111239, in slots at rear while snugging-up collet or extension.

**202/212/230/2400/2480 Tools:** Hold 3/16 hex key (202), 1/4 hex key (230) or 5/16 hex key (212/2400/2480) in hex at rear while snugging-up collet or extension.

**Anvil:** Anvil is pressed out with drift and arbor press - - press new anvil tn squarely to prevent cracking. Thread correct anvil insert into anvil holder. Assemble anvil retainer to anvil.

### 4. Tools with retaining nut and stop as applicable:

Slide holder/anvil over collet; stop and retaining nut over anvil/holder - - tighten hand-tight.

**352 Tool:** Slide holder/anvil over collet until ear depresses half-moon retainer. Turn holder until locked - - if ears do not enter groove, remove shim. On rotatable nose assemblies with retainer, 120738, hold key, 110237, in anvil slot - - retainer ears will enter groove.

5. **As applicable:** See **WARNING** - - connect controls and **RETURN** hose on hydraulic tool.

Reconnect hydraulic unit or air tool/unit to power source. Install fasteners in test plate of correct thickness with proper size holes - - inspect installed fasteners.

Notes:

1. **To extend jaw life:** Disassemble nose assembly periodically; clean and inspect components - - use a pick to clean jaw grooves. **Caution:** Wash parts in **mineral spirits or isopropyl alcohol only.** Dry O-rings: urethane jaw assemblies immediately after cleaning as prolonged contact with solvent causes swelling - dry other parts.

2. **Spare parts - - as required:** Jaws lock collars, shims. press-in anvils, anvil inserts, springs. O-rings. retaining rings and anvil retainers.

3. **Tools/service items - - as required:** Brushes - NYLON bristle - 105805 (04. 05 & 06). 105806 (08). 9/16 collet wrench, 502914. drift, 83097 (.434 wide), staking tool. 84122; 5/32 hex key, 502450. 3/16 hex key, 502451; 1/4 hex key. 502453; 5/16 hex key. 502454; adjustable wrench, 503044; spanner-wrench.111239 (200). Parker SUPER O-LUBE, 505476 (for Springs); VIBRA-TITE 505125.

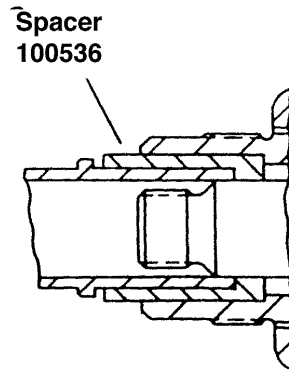

**FIGURE 3**  
**200**

352/200/202/212/230/2400/2480

WO/lock collars. Wears