

PLEASE CHECK WWW.MOLEX.COM FOR LATEST PART INFORMATION

Part Number: [0039000181](#)
Status: **Active**
Overview: [minifit_jr](#)
Description: 4.20mm (.165") Pitch Mini-Fit™ Crimp Terminal, Female, Phosphor Bronze, Gold (Au), 18-24 AWG, Reel

Documents:

Test Summary (PDF)	Product Specification PS-5556-002 (PDF)
Drawing (PDF)	Product Specification PS-5556-003 (PDF)
Product Specification PS-5556-001 (PDF)	RoHS Certificate of Compliance (PDF)

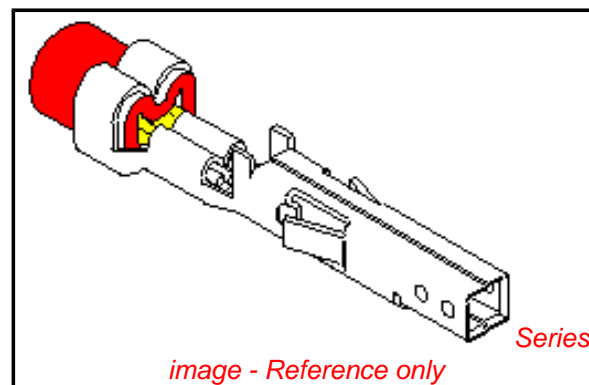

General

Product Family	Crimp Terminals
Series	5556
Crimp Quality Equipment	Yes
Overview	minifit_jr
Product Name	Mini-Fit®

Physical

Durability (mating cycles max)	30
Gender	Female
Material - Metal	Phosphor Bronze
Material - Plating Mating	Gold
Material - Plating Termination	Nickel
Packaging Type	Reel
Plating min: Mating (µin)	30
Plating min: Mating (µm)	0.76
Plating min: Termination (µin)	30
Plating min: Termination (µm)	0.76
Termination Interface: Style	Crimp or Compression
Wire Insulation Diameter	1.30-3.10mm (.051-.122")
Wire Size AWG	18, 20, 22, 24
Wire Size mm²	N/A

Electrical

Current - Maximum per Contact	9A
Voltage - Maximum	600V

Material Info

Old Part Number	5556-PBGSP
-----------------	------------

Reference - Drawing Numbers

Packaging Specification	PK-5556-001
Product Specification	PS-5556-001, PS-5556-002, PS-5556-003
Sales Drawing	SD-5556-GSP*
Test Summary	TS-5556-002

EU RoHS ELV and RoHS Compliant REACH SVHC Contains SVHC: No Halogen-Free Status Halogen-Free	China RoHS
---	-----------------------

Need more information on product environmental compliance?

Email productcompliance@molex.com
 For a multiple part number RoHS Certificate of Compliance, [click here](#)

Please visit the [Contact Us](#) section for any non-product compliance questions.

Search Parts in this Series

5556Series

Mates With

5558 Male Crimp Terminals, Mini-Fit Jr.™ Header, Dual Row, 5566 , 5569

Use With

5557 Mini-Fit Jr.™ Receptacle Housing, 30067 TPA, 42474 BMI Panel Mount, 44516 BMI Slide and Lock Panel Mount

Application Tooling | FAQ

Tooling specifications and manuals are found by selecting the products below. Crimp Height Specifications are then contained in the Application Tooling Specification document.

Global

Description	Product #
FineAdjust™ Applicator for Mini-Fit Jr.™, Mini-Fit HCS™ Crimp Terminals,	0639015600

18-24 AWG and
 smaller insulation
 T2 Terminator Die [0639102600](#)
 FineAdjust™ [0639002600](#)
 Applicator
 FineAdjust™ [0639002900](#)
 Applicator, Small
 Insulation
 T2 Terminator [0639102900](#)
 Tooling Die
 Extraction Tool [0011030044](#)
 Hand Crimp Tool for [0638190900](#)
 Mini-Fit™ Jr. Male
 and Female Crimp
 Terminals, 16-24
 AWG

Japan	
Description	Product #
Applicator for M21 1A	0570223000
Bench Press, 18-24 AWG, for 5556 and 5558 Crimp Terminal	
Side-Feed Applicator	0570223200
For Full-Auto Machine	

This document was generated on 06/01/2010

PLEASE CHECK WWW.MOLEX.COM FOR LATEST PART INFORMATION

NOTES:

1. MATERIAL:

- A. CDA 260 BRASS, .0080±.0004/(0.203±0.010) THICK.
- B. CDA 510 PHOS. BRONZE .0080±.0004/(0.203±0.010) THICK.

2. PLATING:

- *A. SELECTIVE GOLD PLATE .000030/(0.00076) MIN., AND SELECTIVE MATTE TIN .000100/(0.00254) OVER .000050/(0.00127) NICKEL OVERALL.
 - *B. SELECTIVE GOLD PLATE .000015/(0.00038) MIN., AND SELECTIVE MATTE TIN .000100/(0.00254) OVER .000050/(0.00127) NICKEL OVERALL.
 - *C. SELECTIVE GOLD PLATE .000050/(0.00127) MIN., AND SELECTIVE MATTE TIN .000100/(0.00254) OVER .000050/(0.00127) NICKEL OVERALL.
 - *THE PRIMARY SHIPPING CARTON WILL BE LABELED "COMPLIANT TO RoHS DIRECTIVE 2002/95/EC AND ELV ANNEX II OF DIRECTIVE 2000/53/EC." CARTONS WITHOUT THIS LABEL MAY CONTAIN PRODUCT WITH TIN-LEAD PLATING.
- 3. PRODUCT SPECIFICATION** PS-5556-001, PS-5556-002, PS-5556-003
- 4. PACKAGING SPECIFICATION:** PK-5556-001 FOR CHAIN
PK-5556-003 FOR LOOSE.
- 5. MATES WITH** 5558, 5566 AND 5569 SERIES CONNECTORS.
- 6. TERMINAL FOR USE WITH** 5557 SERIES HOUSINGS.

△ THE NUMBER OF SERRATION TO BE ONE FOR WIRE GAUGE #22-28.

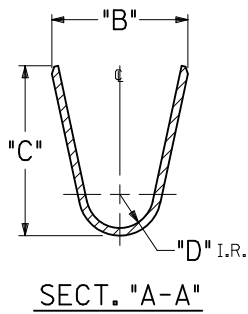
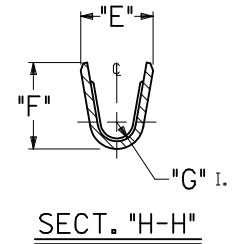
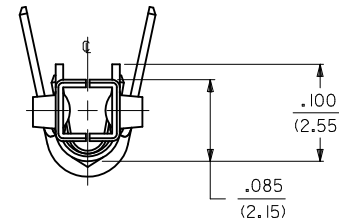
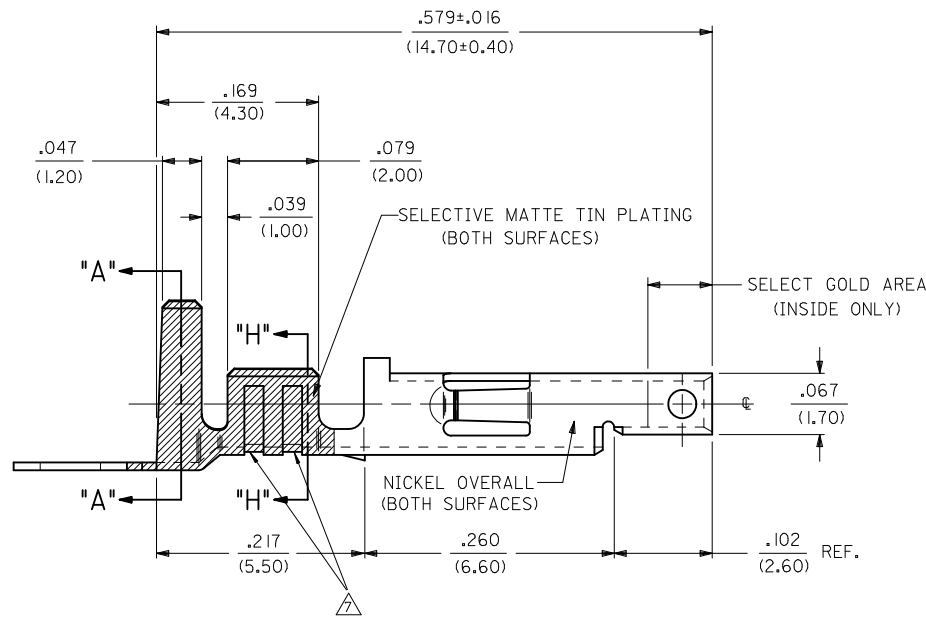
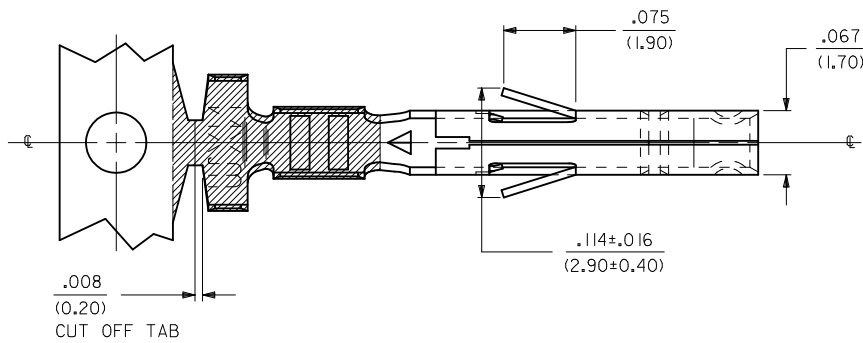

REORDERED NOTES EC NO: UCP2010-1963 DRWN: JAGUILAR 2010/02/08 CHKD: BELL 2010/02/08 APPR: FSMITH 2010/04/09 REV: F2	QUALITY SYMBOLS ▽=0 ▽=0 R.	GENERAL TOLERANCES (UNLESS SPECIFIED) <table border="1"> <tr> <th></th> <th>mm</th> <th>INCH</th> </tr> <tr> <td>4 PLACES</td> <td>± .---</td> <td>± .---</td> </tr> <tr> <td>3 PLACES</td> <td>± .---</td> <td>± .010</td> </tr> <tr> <td>2 PLACES</td> <td>± 0.25</td> <td>± .014</td> </tr> <tr> <td>1 PLACE</td> <td>± 0.36</td> <td>± .---</td> </tr> </table>		mm	INCH	4 PLACES	± .---	± .---	3 PLACES	± .---	± .010	2 PLACES	± 0.25	± .014	1 PLACE	± 0.36	± .---	DIMENSION STYLE IN/MM DRAWN BY: GEP DATE: 5/17/90 CHECKED BY: R/JF DATE: 5/17/90 APPROVED BY: FSMITH DATE: 2010/04/09	SCALE: 10:1 DESIGN UNITS: METRIC THIRD ANGLE PROJECTION	TITLE: TERMINAL, MINI-FIT JR., FEMALE CRIMP SELECT GOLD BLANK PLATE FORM MOLEX INCORPORATED DOCUMENT NO. SD-5556-GSP* SHEET NO. 1 OF 2
		mm	INCH																	
	4 PLACES	± .---	± .---																	
	3 PLACES	± .---	± .010																	
2 PLACES	± 0.25	± .014																		
1 PLACE	± 0.36	± .---																		
DRAFT WHERE APPLICABLE MUST REMAIN WITHIN DIMENSIONS	MATERIAL NO. SEE SHT. 2 SIZE: C	THIS DRAWING CONTAINS INFORMATION THAT IS PROPRIETARY TO MOLEX INCORPORATED AND SHOULD NOT BE USED WITHOUT WRITTEN PERMISSION																		

PART NO.	ENG. NO.	MAT'L.	PLATE	WIRE GAGE	QUANTITY PER REEL	DIM. "B"	DIM. "C"	DIM. "D"	DIM. "E"	DIM. "F"	DIM. "G"		
NOT TOOLED	5556-GS10P	A	A	14 GA.	4,000	.142±.012	.177±.016	.035	.091±.012	.114±.016	.024		
NOT TOOLED	5556-GS10PL					(3.60±0.30)	(4.50±0.40)	(0.90)	(2.30±0.30)	(2.90±0.40)	(0.60)		
39-00-0169	5556-GS4P	A	B	18-24 GA.	4,000	.142±.012	.177±.016	.035	.075±.012	.091±.016	.020		
39-00-0170	5556-GS4PL					(3.60±0.30)	(4.50±0.40)	(0.90)	(1.90±0.30)	(2.40±0.40)	(0.50)		
39-00-0171	5556-GS5P			22-28 GA.	6,000	.091±.012	.091±.016	.024	.071±.012	.065±.016	.016		
39-00-0172	5556-GS5PL					(2.30±0.30)	(2.30±0.40)	(0.60)	(1.80±0.30)	(1.65±0.40)	(0.40)		
39-00-0173	5556-GS6P			16 GA.	4,000	.142±.012	.177±.016	.035	.091±.012	.106±.016	.024		
39-00-0174	5556-GS6PL					(3.60±0.30)	(4.50±0.40)	(0.90)	(2.30±0.30)	(2.70±0.40)	(0.60)		
NOT TOOLED	5556-GS11P			14 GA.	4,000	.142±.012	.177±.016	.035	.091±.012	.114±.016	.024		
NOT TOOLED	5556-GS11PL					(3.60±0.30)	(4.50±0.40)	(0.90)	(2.30±0.30)	(2.90±0.40)	(0.60)		
39-00-0175	5556-GS7P			A	C	18-24 GA.	4,000	.142±.012	.177±.016	.035	.075±.012	.091±.016	.020
39-00-0176	5556-GS7PL							(3.60±0.30)	(4.50±0.40)	(0.90)	(1.90±0.30)	(2.40±0.40)	(0.50)
39-00-0177	5556-GS8P	22-28 GA.	6,000			.091±.012	.091±.016	.024	.071±.012	.065±.016	.016		
39-00-0178	5556-GS8PL					(2.30±0.30)	(2.30±0.40)	(0.60)	(1.80±0.30)	(1.65±0.40)	(0.40)		
39-00-0179	5556-GS9P	16 GA.	4,000			.142±.012	.177±.016	.035	.091±.012	.106±.016	.024		
39-00-0180	5556-GS9PL					(3.60±0.30)	(4.50±0.40)	(0.90)	(2.30±0.30)	(2.70±0.40)	(0.60)		
NOT TOOLED	5556-GS12P	14 GA.	4,000			.142±.012	.177±.016	.035	.091±.012	.114±.016	.024		
NOT TOOLED	5556-GS12PL					(3.60±0.30)	(4.50±0.40)	(0.90)	(2.30±0.30)	(2.90±0.40)	(0.60)		
39-00-0181	5556-PBGSP	B	A			18-24 GA.	4,000	.142±.012	.177±.016	.035	.075±.012	.091±.016	.020
39-00-0182	5556-PBGSPPL							(3.60±0.30)	(4.50±0.40)	(0.90)	(1.90±0.30)	(2.40±0.40)	(0.50)
39-00-0183	5556-PBGSP2P			22-28 GA.	6,000	.091±.012	.091±.016	.024	.071±.012	.065±.016	.016		
39-00-0184	5556-PBGSP2PL					(2.30±0.30)	(2.30±0.40)	(0.60)	(1.80±0.30)	(1.65±0.40)	(0.40)		
39-00-0185	5556-PBGSP3P			16 GA.	4,000	.142±.012	.177±.016	.035	.091±.012	.106±.016	.024		
39-00-0186	5556-PBGSP3PL					(3.60±0.30)	(4.50±0.40)	(0.90)	(2.30±0.30)	(2.70±0.40)	(0.60)		
NOT TOOLED	5556-PBGSP10P			14 GA.	4,000	.142±.012	.177±.016	.035	.091±.012	.114±.016	.024		
NOT TOOLED	5556-PBGSP10PL					(3.60±0.30)	(4.50±0.40)	(0.90)	(2.30±0.30)	(2.90±0.40)	(0.60)		
39-00-0194	5556-PBGSP4P			B	B	18-24 GA.	4,000	.142±.012	.177±.016	.035	.075±.012	.091±.016	.020
39-00-0195	5556-PBGSP4PL							(3.60±0.30)	(4.50±0.40)	(0.90)	(1.90±0.30)	(2.40±0.40)	(0.50)
39-00-0196	5556-PBGSP5P	22-28 GA.	6,000			.091±.012	.091±.016	.024	.071±.012	.065±.016	.016		
39-00-0197	5556-PBGSP5PL					(2.30±0.30)	(2.30±0.40)	(0.60)	(1.80±0.30)	(1.65±0.40)	(0.40)		
39-00-0198	5556-PBGSP6P	16 GA.	4,000			.142±.012	.177±.016	.035	.091±.012	.106±.016	.024		
39-00-0199	5556-PBGSP6PL					(3.60±0.30)	(4.50±0.40)	(0.90)	(2.30±0.30)	(2.70±0.40)	(0.60)		
NOT TOOLED	5556-PBGSP11P	14 GA.	4,000			.142±.012	.177±.016	.035	.091±.012	.114±.016	.024		
NOT TOOLED	5556-PBGSP11PL					(3.60±0.30)	(4.50±0.40)	(0.90)	(2.30±0.30)	(2.90±0.40)	(0.60)		
39-00-0200	5556-PBGSP7P	B	C			18-24 GA.	4,000	.142±.012	.177±.016	.035	.075±.012	.091±.016	.020
39-00-0201	5556-PBGSP7PL							(3.60±0.30)	(4.50±0.40)	(0.90)	(1.90±0.30)	(2.40±0.40)	(0.50)
39-00-0202	5556-PBGSP8P			22-28 GA.	6,000	.091±.012	.091±.016	.024	.071±.012	.065±.016	.016		
39-00-0203	5556-PBGSP8PL					(2.30±0.30)	(2.30±0.40)	(0.60)	(1.80±0.30)	(1.65±0.40)	(0.40)		
39-00-0204	5556-PBGSP9P			16 GA.	4,000	.142±.012	.177±.016	.035	.091±.012	.106±.016	.024		
39-00-0205	5556-PBGSP9PL					(3.60±0.30)	(4.50±0.40)	(0.90)	(2.30±0.30)	(2.70±0.40)	(0.60)		
NOT TOOLED	5556-PBGSP12P			14 GA.	4,000	.142±.012	.177±.016	.035	.091±.012	.114±.016	.024		
NOT TOOLED	5556-PBGSP12PL					(3.60±0.30)	(4.50±0.40)	(0.90)	(2.30±0.30)	(2.90±0.40)	(0.60)		

LEGEND:

5556-***GS*P*

BASE NO. _____

MATERIAL _____

BLANK= BRASS

PB= PHOS. BRONZE

GOLD, SELECT _____

PLATING & CRIMP SIZE COMB. _____

BLANK THRU 15

BLANK-PLATE-FORM VERSION _____

CHAIN OR LOOSE _____

BLANK= CHAIN

L= LOOSE

SEE SHEET 1 EC NO: UCP2010-1963 DRWN: JAGUILAR 2010/02/08 CHKD: J.BELL 2010/02/08 APPR: FSMITH 2010/04/09 F2	QUALITY SYMBOLS 	GENERAL TOLERANCES (UNLESS SPECIFIED)		DIMENSION STYLE IN/MM	SCALE ---	DESIGN UNITS METRIC	THIRD ANGLE PROJECTION
		4 PLACES ± --- ± --- 3 PLACES ± --- ± --- 2 PLACES ± --- ± --- 1 PLACE ± --- ± ---	mm INCH	DRAWN BY GEP DATE 5/17/90	TITLE TERMINAL, MINI-FIT JR., FEMALE, CRIMP, SELECT GOLD BLANK-PLATE-FORM		
		ANGULAR ±1/2°		CHECKED BY RJF DATE 5/17/90	MOLEX INCORPORATED		
		DRAFT WHERE APPLICABLE MUST REMAIN WITHIN DIMENSIONS		APPROVED BY FSMITH DATE 2010/04/09	MATERIAL NO. SEE CHART	DOCUMENT NO. SD-5556-GSP*	SHEET NO. 2 2

THIS DRAWING CONTAINS INFORMATION THAT IS PROPRIETARY TO MOLEX INCORPORATED AND SHOULD NOT BE USED WITHOUT WRITTEN PERMISSION