

Remote I/O R7K4F Series

MECHATROLINK I/O MODULE

(NPN transistor output, 32 points, screw terminal block, MECHATROLINK-I/-II use)

Functions & Features

- 32 points NPN transistor output module for MECHATROLINK-I/-II

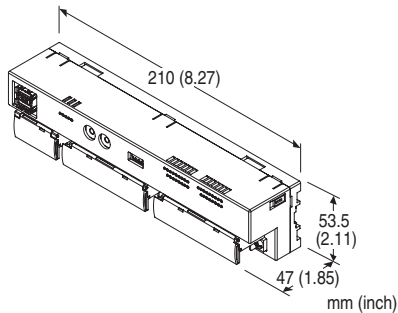

MODEL: R7K4FML-6-DC32A-R[1]

ORDERING INFORMATION

- Code number: R7K4FML-6-DC32A-R[1]
Specify a code from below for [1].
(e.g. R7K4FML-6-DC32A-R/Q)
- Specify the specification for option code /Q
(e.g. /C01)

TERMINAL BLOCK

- 6: Screw terminal block for power supply
Connector for MECHATROLINK-I/-II
Screw terminal block for I/O

I/O TYPE

DC32A: NPN transistor output, 32 points

POWER INPUT

DC power

R: 24 V DC

(Operational voltage range: $\pm 10\%$; ripple 10 %p-p max.)

[1] OPTIONS

blank: none

/Q: With options (specify the specification)

SPECIFICATIONS OF OPTION: Q

COATING (For the detail, refer to M-System's web site.)

/C01: Silicone coating

/C02: Polyurethane coating

/C03: Rubber coating

GENERAL SPECIFICATIONS

Connection

MECHATROLINK: MECHATROLINK-I/-II connector

Power input, output: M3 separable screw terminal (torque 0.5 N·m)

Solderless terminal: Refer to the drawing at the end of the section.

Recommended manufacturer: Japan Solderless Terminal MFG.Co.Ltd, Nichifu Co.,Ltd

Applicable wire size: 0.25 to 1.65 mm² (AWG 22 to 16)

Screw terminal: Nickel-plated steel

Housing material: Flame-resistant resin (gray)

Isolation: Output to MECHATROLINK or FE to power

Status indicator LED: PWR, ERR, SD, RD

(Refer to the instruction manual for details)

Discrete output status indicator LED: Green LED turns on with output ON

Recommended solderless terminal

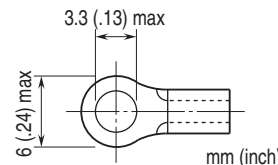

MECHATROLINK COMMUNICATION

MECHATROLINK mode: Set with DIP switches

(MECHATROLINK-I or -II, data length; Factory setting:

MECHATROLINK-II; data length (32 byte)

(Refer to the instruction manual)

Station address: 60H - 7FH

(Function selected with Rotary SW. Factory setting: 61H).

(Refer to the instruction manual)

MECHATROLINK-I

Baud rate: 4 Mbps

Transmission distance: 50 m max.

Distance between stations: 30 cm min.

Transmission media: MECHATROLINK cable (Model JEPMC-W6003-x-E, Yaskawa Controls Co., Ltd.)

Max. number of slaves: 15

(The maximum number of slaves might change depending on the master unit. Refer to the manual of the master unit)

Transmission cycle: 2 msec. (fixed)

Data length: 17 byte

■ MECHATROLINK-II

Baud rate: 10 Mbps

Transmission distance: 50 m max.

Distance between stations: 50 cm min.

Transmission media: MECHATROLINK cable (Model JEPMC-W6003-x-E, Yaskawa Controls Co., Ltd.)

Max. number of slaves: 30

(The maximum number of slaves might change depending on the master unit. Refer to the manual of the master unit)

Transmission cycle: 0.25 msec., 0.5 msec., 1 msec., 1.5 msec., 2 msec., 4 msec., 8 msec.

Data length: 17 bytes / 32 bytes selectable (Must choose identical data size for all stations on one network)

EMI EN 61000-6-4

EMS EN 61000-6-2

RoHS Directive

EN 50581

OUTPUT SPECIFICATIONS

Common: Negative common (NPN) per 32 points

Maximum outputs applicable at once: No limit (at 24 V DC)

Rated load voltage: 24 V DC $\pm 10\%$, ripple 5 %p-p max.

Rated output current: 0.1 A per point, 3.2 A (two points total) per common

Residual voltage: ≤ 1.2 V

Leakage current: ≤ 0.1 mA

ON delay: ≤ 0.2 msec.

OFF delay: ≤ 0.5 msec.

Overload current protection function: Limits the current value when overcurrent is detected

Overheat protection function: Turns OFF the outputs when overheat is detected

(When driving an inductive load, connect a diode in parallel with the load.)

INSTALLATION

Current consumption

•DC: Approx. 60 mA

Operating temperature: 0 to 55°C (32 to 131°F)

Storage temperature: -20 to +65°C (-4 to +149°F)

Operating humidity: 30 to 90 %RH (non-condensing)

Atmosphere: No corrosive gas or heavy dust

Mounting: Surface or DIN rail (35 mm rail)

Weight: 330 g (0.73 lb)

PERFORMANCE

Insulation resistance: ≥ 100 M Ω with 500 V DC

Dielectric strength: 1500 V AC @ 1 minute (output to power)

500 V AC @ 1 minute (MECHATROLINK or FE to output or power)

STANDARDS & APPROVALS

EU conformity:

EMC Directive

EXTERNAL VIEW

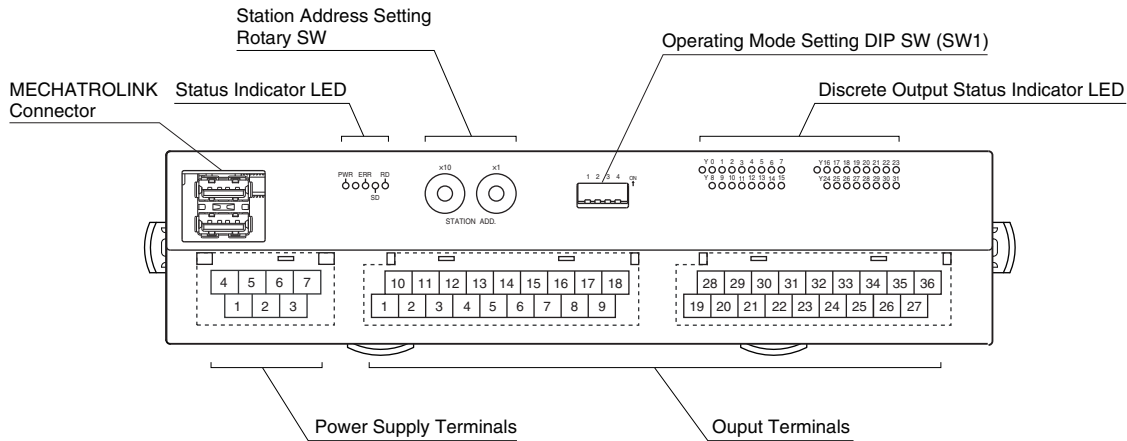

TERMINAL ASSIGNMENTS

OUTPUT TERMINAL ASSIGNMENT

10	11	12	13	14	15	16	17	18
V+	Y1	Y3	Y5	Y7	Y9	Y11	Y13	Y15
1	2	3	4	5	6	7	8	9
V-	Y0	Y2	Y4	Y6	Y8	Y10	Y12	Y14

28	29	30	31	32	33	34	35	36
V+	Y17	Y19	Y21	Y23	Y25	Y27	Y29	Y31
19	20	21	22	23	24	25	26	27
V-	Y16	Y18	Y20	Y22	Y24	Y26	Y28	Y30

NO.	ID	FUNCTION	NO.	ID	FUNCTION	NO.	ID	FUNCTION	NO.	ID	FUNCTION
1	V-	Out. Common	10	V+	External excitation	19	V-	Out. Common	28	V+	External excitation
2	Y0	Output 0	11	Y1	Output 1	20	Y16	Output 16	29	Y17	Output 17
3	Y2	Output 2	12	Y3	Output 3	21	Y18	Output 18	30	Y19	Output 19
4	Y4	Output 4	13	Y5	Output 5	22	Y20	Output 20	31	Y21	Output 21
5	Y6	Output 6	14	Y7	Output 7	23	Y22	Output 22	32	Y23	Output 23
6	Y8	Output 8	15	Y9	Output 9	24	Y24	Output 24	33	Y25	Output 25
7	Y10	Output 10	16	Y11	Output 11	25	Y26	Output 26	34	Y27	Output 27
8	Y12	Output 12	17	Y13	Output 13	26	Y28	Output 28	35	Y29	Output 29
9	Y14	Output 14	18	Y15	Output 15	27	Y30	Output 30	36	Y31	Output 31

POWER SUPPLY TERMINAL ASSIGNMENT

4	5	6	7
NC	NC	+24V	0V
1	2	3	
NC	NC	FE	

- 1. NC -
- 2. NC -
- 3. FE Functional earth
- 4. NC -
- 5. NC -
- 6. +24V Power supply (24V DC)
- 7. 0V Power supply (0V)

MECHATROLINK CONNECTION

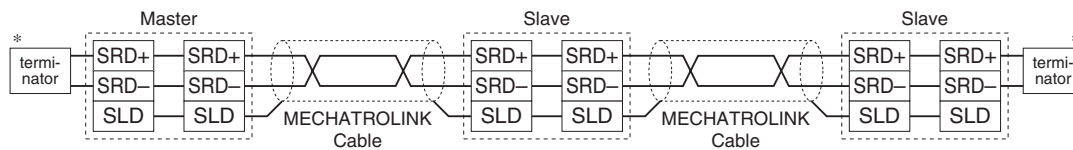

* Terminator

Be sure to connect the terminating resistors to the unit at both ends of transmission line.

Use the terminating resistor dedicated for MECHATROLINK: Model JEPMC-W6022, Yaskawa Controls Co., Ltd.

Certain types of Master units may have incorporated terminating resistors. Consult the instruction manual of the Master unit.

MECHATROLINK RELATED COMMANDS

R7K4FML (Simple I/O) communicates with I/O service with no processor, therefore it uses a connectionless communication protocol. There is no application layer either; the R7K4FML interchanges I/O data via data link layer.

■ MECHATROLINK DATA LINK LAYER COMMAND DESCRIPTIONS

The following tables explain the two Commands supported by the R7K4FML.

• MDS Command (04H) Data Format

BYTE	COMMAND	RESPONSE	REMARKS
0	MDS (04H)	S(0) (90H)	Message Data Search (MDS) Command: Read the ID from slave station(s) S(0): Response to MDS
1	0	ID	
2	0		
3	0		
4	0	0	All 0
5	0	0	
6	0	0	
7	0	0	
8	0	0	
9	0	0	
10	0	0	
11	0	0	
12	0	0	
13	0	0	
14	0	0	
15	0	0	
16	0	0	
17	0	0	Byte 17 through 31 are always 0 in the 32-byte mode. These bytes are unavailable for MECHATROLINK-I and MECHATROLINK-II in the 17-byte mode.
:	:	:	
31	0	0	

• CDRW Command (03H) Data Format

BYTE	COMMAND	RESPONSE	REMARKS
0	CDRW (03H)	ACK (01H)	Cyclic Data Read/Write (CDRW) Command: Link transmission Acknowledge (ACK): Positive response to CDRW
1	Out Data: Lowest	In Data: Lowest	Order of data: Little Endian
2			
3			
4			
5			
6			
7			
8			
9			
10			
11			
12			
13			
14			
15			
16	Out Data: Highest	In Data: Highest	
17	(Out Data: Highest)	(In Data: Highest)	Byte 17 through 31 are unavailable for MECHATROLINK-I and MECHATROLINK-II in the 17-byte mode. (Only available for MECHATROLINK-II in the 32-byte mode)
:			
31			

I/O DATA DESCRIPTIONS

■ DISCRETE OUTPUT

Out 0 to 31: 0: OFF, 1: ON

• 17-BYTE MODE

32 points output, Out Data

Byte	Bit7	Bit6	Bit5	Bit4	Bit3	Bit2	Bit1	Bit0
1	0	0	0	0	0	0	0	0
2	0	0	0	0	0	0	0	0
3	0	0	0	0	0	0	0	0
4	0	0	0	0	0	0	0	0
5	0	0	0	0	0	0	0	0
⋮	0	0	0	0	0	0	0	0
12	0	0	0	0	0	0	0	0
13	Out7	Out6	Out5	Out4	Out3	Out2	Out1	Out0
14	Out15	Out14	Out13	Out12	Out11	Out10	Out9	Out8
15	Out23	Out22	Out21	Out20	Out19	Out18	Out17	Out16
16	Out31	Out30	Out29	Out28	Out27	Out26	Out25	Out24

• 32-BYTE MODE

32 points output, Out Data

Byte	Bit7	Bit6	Bit5	Bit4	Bit3	Bit2	Bit1	Bit0
1	0	0	0	0	0	0	0	0
2	0	0	0	0	0	0	0	0
3	0	0	0	0	0	0	0	0
4	0	0	0	0	0	0	0	0
5	0	0	0	0	0	0	0	0
⋮	0	0	0	0	0	0	0	0
28	0	0	0	0	0	0	0	0
29	Out7	Out6	Out5	Out4	Out3	Out2	Out1	Out0
30	Out15	Out14	Out13	Out12	Out11	Out10	Out9	Out8
31	Out23	Out22	Out21	Out20	Out19	Out18	Out17	Out16
32	Out31	Out30	Out29	Out28	Out27	Out26	Out25	Out24

EXTERNAL DIMENSIONS & TERMINAL ASSIGNMENTS unit: mm (inch)

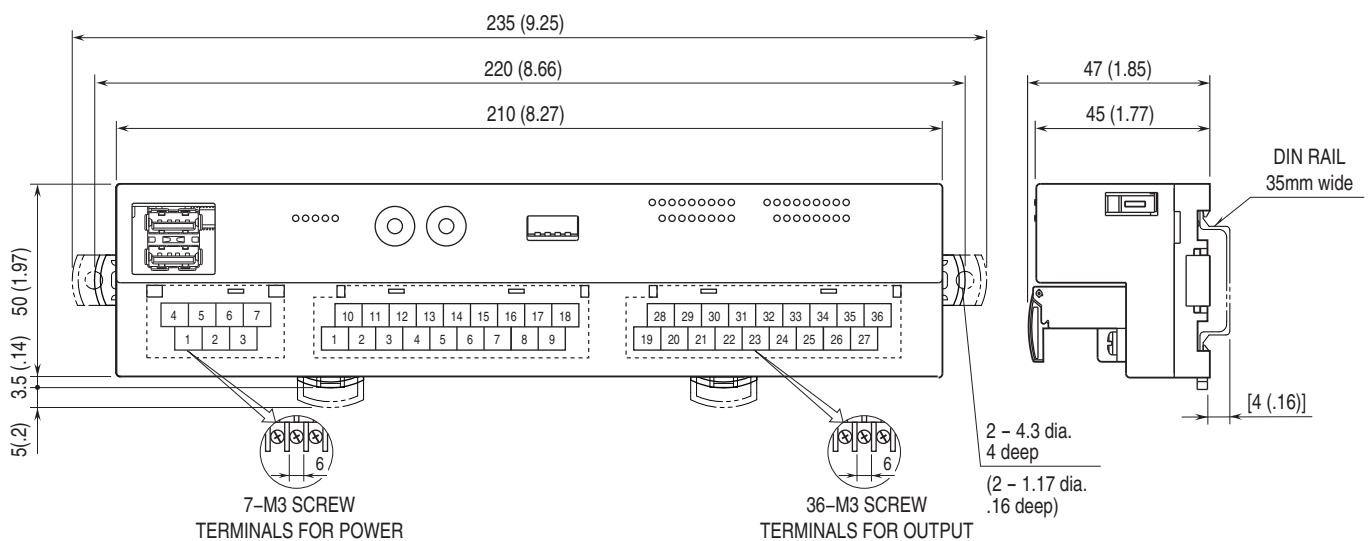

MODEL: R7K4FML-6-DC32A

MOUNTING REQUIREMENTS unit: mm (inch)



SCHEMATIC CIRCUITRY & CONNECTION DIAGRAM

Note: In order to improve EMC performance, bond the FE terminal to ground.

Caution: FE terminal is NOT a protective conductor terminal.

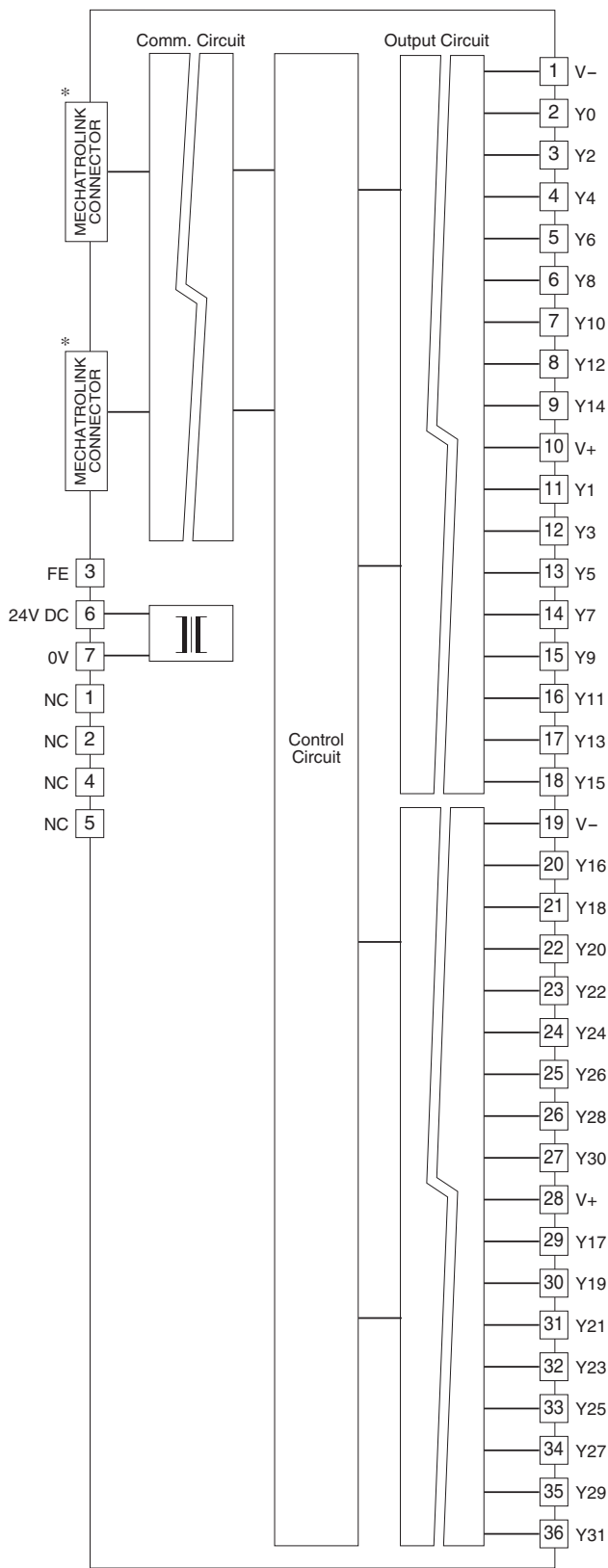

*MECHATROLINK connectors are internally connected.
The network cable can be connected to either one.

Output Circuit

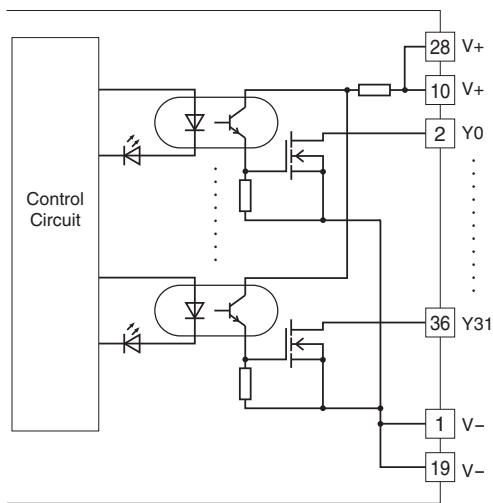

Output Connection Examples

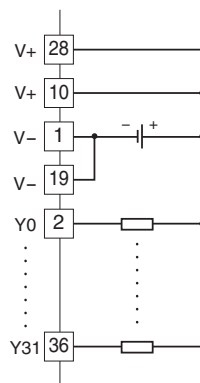



Specifications are subject to change without notice.