

Monolithic, 12-Bit Data Acquisition System

- Complete Monolithic 8-Channel, 12-Bit DAS
- 100kHz Throughput
- 16-Bit Microprocessor Bus Interface
- Latched MUX Address
- All-channel Deselect
- 8/4-Bit Nibble Output
- No Missing Codes to 12-Bits
- 32-Pin Packages
- 200mW Max Power Dissipation



* Formerly part of the SP410 Series.

DESCRIPTION...

The **SP8481 Series** are complete monolithic data acquisition systems, featuring 8-channel multiplexer, internal reference and 12-bit sampling A/D converter in 32-pin packages. Linearity errors of ± 0.5 and ± 1.0 LSB, and Differential Non-linearity to 12-bits is guaranteed, with no missing codes over temperature. Channel-to-channel crosstalk is typically -85dB. Multiplexer settling plus acquisition time is 1.9 μ s maximum; A/D conversion time is 8.1 μ s maximum.

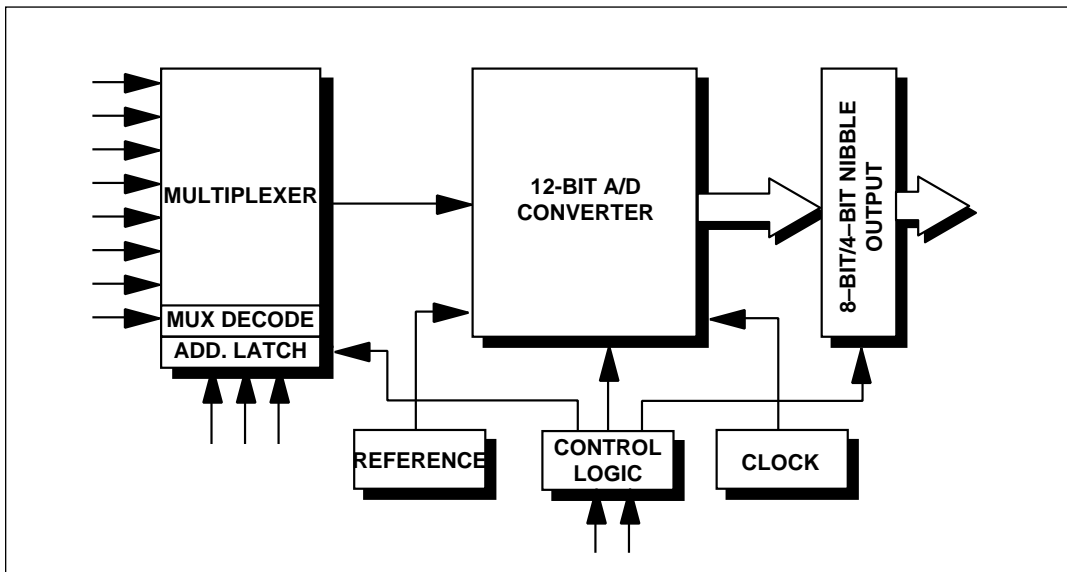

ABSOLUTE MAXIMUM RATINGS

V _{CC} to Common Ground	0V to +16.5V
V _{LOGIC} to Common Ground	0V to +7V
Analog Common to Digital Common Ground	-0.5V to +1V
Digital Inputs to Common Ground	-0.5V to V _{I,LOGIC} +0.5V
Digital Outputs to Common Ground	-0.5V to V _{I,LOGIC} +0.5V
Multiplexer Analog Inputs	-16.5V to +31.5V
Gain and Offset Adjustment	-0.5V to V _{CC} +0.5V
Analog Input Maximum Current	25mA
Temperature with Bias Applied	-55°C to +125°C
Storage Temperature	-65°C to +150°C
Lead Temperature, Soldering	300°C, 10sec



CAUTION:
ESD (ElectroStatic Discharge) sensitive device. Permanent damage may occur on unconnected devices subject to high energy electrostatic fields. Unused devices must be stored in conductive foam or shunts. Personnel should be properly grounded prior to handling this device. The protective foam should be discharged to the destination socket before devices are removed.

SPECIFICATIONS

(T_A = 25°C and nominal supply voltages unless otherwise noted)

	MIN.	TYP.	MAX.	UNIT	CONDITIONS
ANALOG INPUTS					
Input Voltage Range		0 to +5		V	
Multiplexer Inputs Configuration		Single-ended	8		
Input Impedance					
ON Channel		10 ⁹		Ω	Parallel with 30pF
OFF Channel		10 ¹⁰		Ω	Parallel with 5pF
Input Bias Current					
Per Channel		±10		nA	25°C
		±250		nA	-55°C to +125°C
Crosstalk					
OFF to ON Channel			-90	dB	10kHz, 0V to +5V _{Pk-to-pk}
			-80	dB	50kHz, 0V to +5V _{Pk-to-pk}
			-70	dB	100kHz, 0V to +5V _{Pk-to-pk}
ACCURACY					
Resolution	12			Bits	
Linearity Error					
-K, -B			±0.5	LSB	
-J, -A			±1	LSB	
Differential Non-Linearity					
-K, -B			±1	LSB	
-J, -A			±2	LSB	
Offset Error		±2		LSB	Adjustable to zero
Gain Error		±0.3		%FSR	Adjustable to zero
No Missing Codes					
-K, -B		Guaranteed			
TRANSFER CHARACTERISTICS					
Throughput Rate	100			kHz	
MUX Settling/Acquisition			1.9	μs	
A/D Conversion			8.1	μs	
STABILITY					
Linearity		±0.5	±2.5	ppm/°C	
Offset		±5	±25	ppm/°C	
Gain		±10	±50	ppm/°C	
DIGITAL INPUTS					
Capacitance		5		pF	
Logic Levels					
V _{IH}	+2.4		+5.5	V	
V _{IL}	-0.5		+0.8	V	
I _{IH}			±5	μA	
I _{IL}			±5	μA	

SPECIFICATIONS (continued)

($T_A = 25^\circ\text{C}$ and nominal supply voltages unless otherwise noted)

	MIN.	TYP.	MAX.	UNIT	CONDITIONS
DIGITAL OUTPUTS					
Capacitance		5		pF	
Logic Levels					
V_{OH}	+2.4			V	$I_{OH} \leq 500\mu\text{A}$ $I_{OL} \leq 1.6\text{mA}$ High impedance, data bits only
V_{OL}			+0.4	V	
Leakage Current		± 40		μA	
Data Output		Offset Binary			
POWER REQUIREMENTS					
V_{LOGIC}	+4.5		+5.5	V	
I_{LOGIC}		0.8	2	mA	
V_{CC}	+11.4		+16.5	V	
I_{CC}		9	12	mA	
Power Dissipation		140	200	mW	
ENVIRONMENTAL					
Operating Temperature					
Commercial; -J, -K	0		+70	$^\circ\text{C}$	
Industrial; -A, -B	-40		+85	$^\circ\text{C}$	
Storage Temperature	-65		+150	$^\circ\text{C}$	

PIN ASSIGNMENTS...

(Refer to Page 11 for package configurations and dimensions)

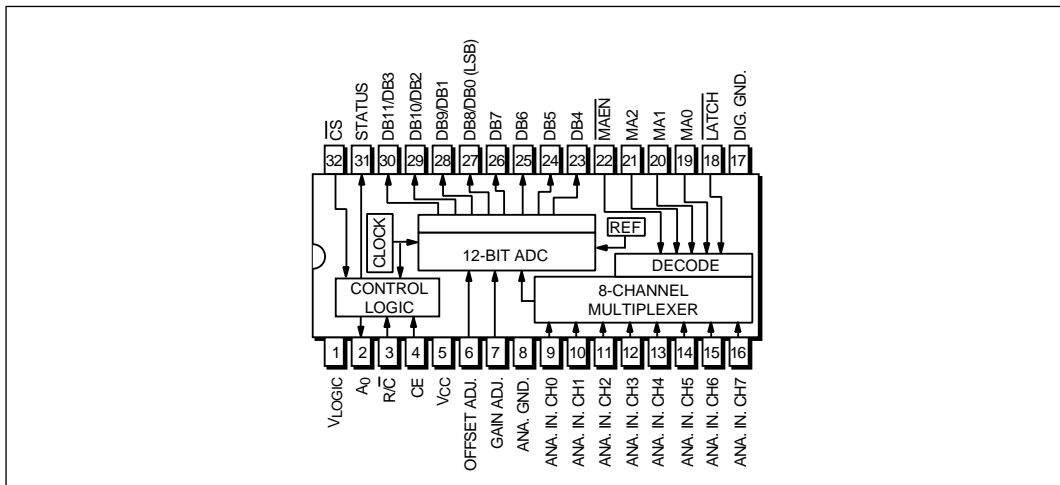

PIN FUNCTION...

R/\bar{C} — Read/ \bar{C} onvert — Initiates conversion on the Hi-to-low transition; logic low disconnects data bus; logic high initiates read

$\bar{C}S$ — Chip Select — Logic high disconnects data bus; logic low allows conversion or reading of data

CE — Chip Enable — Logic low disables read or convert; logic high enables read or convert

A_0 — Device Address — Logic low enables 8 MSB read; logic high enables 4 LSB read

MA_0, MA_1, MA_2 — MUX Address 0, 1 & 2 — Selects analog input channels CH_0 through CH_7

LATCH — MUX Address Latch — Logic high to low transition captures MUX address on MUX address lines

MAEN — MUX Enable — Logic low allows normal MUX address; logic high deselects CH_0 through CH_7

DB_0 through DB_{11} — Data Outputs — Logic high is binary true; logic low binary false

MULTIPLEXER TRUTH TABLE

LATCH	MAEN	MA_2	MA_1	MA_0	OPERATION
H → L	0	0	0	0	CH_0 Selected
H → L	0	0	0	1	CH_1 Selected
H → L	0	0	1	0	CH_2 Selected
H → L	0	0	1	1	CH_3 Selected
H → L	0	1	0	0	CH_4 Selected
H → L	0	1	0	1	CH_5 Selected
H → L	0	1	1	0	CH_6 Selected
H → L	0	1	1	1	CH_7 Selected
H → L	1	n	n	n	All Deselected
0	X	X	X	X	Prev. Ch. n Held
1	X	X	X	X	Prev. Ch. n Held

Table 1. Multiplexer Truth Table

CONTROL TRUTH TABLE

CE	$\bar{C}S$	A_0	R/\bar{C}	OPERATION
0	X	X	X	None
X	1	X	X	None
L → H	0	0	X	Start Conversion
1	H → L	0	X	Start Conversion
1	0	H → L	X	Start Conversion
1	0	1	0	Enable 8 MSBs
1	0	1	1	Enable 4 LSBs

Table 2. Control Truth Table

FEATURES...

The **SP8481 Series** are complete data acquisition systems, featuring 8-channel multiplexer, internal reference and 12-bit sampling A/D converter implemented as a single monolithic IC. The analog multiplexer accepts 0V to +5V unipolar full scale inputs. Output data is formatted as an 8-bit/4-bit nibble.

Linearity errors of ± 0.5 and ± 1.0 LSB, and Differential Non-linearity to 12-bits is guaranteed, with no missing codes over temperature. Channel-to-channel crosstalk is typically -85dB. Multiplexer settling plus acquisition time is 1.9 μ s maximum; A/D conversion time is 8.1 μ s maximum.

Versions of the **SP8481 Series** are available in 32-pin plastic DIP or SOIC packages. Operating temperature ranges are 0°C to +70°C commercial and -40°C to +85°C industrial.

CIRCUIT OPERATION...

The **SP8481** is a complete 8-channel data acquisition system (DAS), with on-board multiplexer, voltage reference, sample-and-hold, clock and tri-state outputs. The digital control architecture is very similar to the industry-standard 574-type A/D, and uses identical control lines and digital states.

The multiplexer for the **SP8481** is identical in operation to many discrete devices available today, except that it has been integrated into the single-chip DAS. The appropriate channel is selected using the MUX address lines MA₀, MA₁, and MA₂ per the truth table. The selected analog input is fed through to the ADC. The input impedance into any MUX channel will be on the order to 10⁹ ohms, since it is connected to the integral sampling structure of the capacitor DAC. Crosstalk is kept to -85dB at 0V to 5V_{p-p} over an input frequency range of 10kHz to 50kHz.

When the control section of the **SP8481** initiates a conversion command the internal clock is enabled, and the successive approximation register (SAR) is reset to all zeros. Once the conversion has been started it cannot be stopped or restarted. Data is not available at the output

buffers until the conversion has been completed.

The SAR, timed by the clock, sequences through the conversion cycle and returns an end-of-convert flag to the control section of the ADC. The clock is then disabled by the control section, which puts the STATUS output line low. The control section is enabled to allow the data to be read by external command (R/ \bar{C}).

Multiplexer Control and Inputs

On the **SP8481** the multiplexer inputs are latched with LATCH. The address line latches MA₀, MA₁ and MA₂ select the appropriate analog input channel. When low, the LATCH line retains the last MUX address data, and therefore the previously addressed MUX channel. All channels may be deselected by bringing the MAEN control line to a logic "1". When this control function is used, the analog input will be connected to pin 8 or analog ground.

Since the MUX address latches are controlled by the LATCH and MAEN control lines, MUX channel select data need not be held by the bus for any minimum period after the conversion has been initiated. However it is advisable that the MUX not be changed at all during the full 10 μ s conversion time due to capacitive coupling effects of digital edges through the silicon.

The **SP8481** multiplexer inputs have been designed to allow substantial overvoltage conditions to occur without any damage. The inputs are diode-clamped and further protected with a 200 Ω series resistor. As a result, momentary (10 seconds) input voltages can be as low as -16.5V or as high as +31.5V with no change or degradation in multiplexer performance or crosstalk. This feature allows the output voltage of an externally connected op amp to swing to ± 15 V supply levels with no multiplexer damage. Complicated power-up sequencing is not required to protect the **SP8481**. The multiplexer inputs may be damaged, however, if the inputs are allowed to either source or sink greater than 100mA.

Initiating a Conversion

The **SP8481** was designed to require a minimum of control to perform a 12-bit conversion. The control input used is R/ \bar{C} which tri-states the

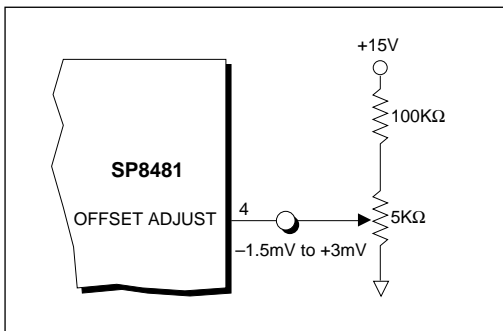

Figure 1. Offset Adjust

outputs when high and starts the conversion when low. \overline{CS} and CE may also be used with R/\overline{C} to initiate a conversion. The last of the three inputs to reach the correct state starts the conversion, therefore one, two or all three may be dynamically controlled. The nominal delay from all three is the same and they may change state simultaneously. In order to ensure that a particular input controls the conversion the other two should be set up at least 50ns earlier. The STATUS line indicates when a conversion is in process and when it is complete. The A_0 input is used to configure the output data.

The conversion cycle is started when R/\overline{C} is brought low and must be held low for a minimum of 50ns. The R/\overline{C} signal will also put the output latches in a tri-state mode when low. Approximately 200ns after R/\overline{C} is low, STATUS will change from low to high. This output signal will stay high while the SP8481 is performing a conversion. Valid data will be latched to the output bus, through internal control, 500ns prior to the STATUS line transitioning from a high to low.

Reading the Data

The output data buffers will remain in a high impedance state until the following four conditions are met: R/\overline{C} is HIGH, STATUS is LOW, CE is HIGH and \overline{CS} is LOW. The data lines become active in response to the four conditions and will latch data according to the conditions of A_0 line. Please refer to Figure 5 for the appropriate timing. All conditions must be met at least 50ns prior to reading the data to allow sufficient time for the output latches to come out of the high impedance state. A_0 is used to access the data.

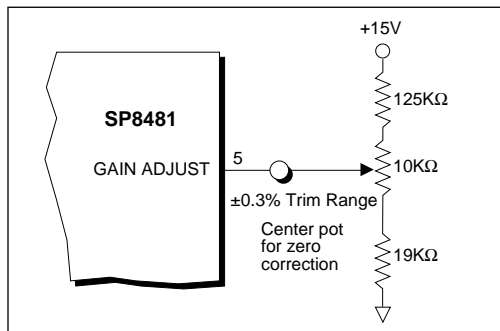

Figure 2. Gain Adjust

The first 8 MSBs will be on pins 26 through 19, with pin 26 being the MSB. The remaining 4 LSBs will be on pins 23 through 26 with pin 23 being the LSB. When A_0 is switched from one state to the next, there is a 50ns output latch propagation delay between the MSBs and LSBs being present on the output pins.

CALIBRATION

The calibration procedure for the SP8481 consists of adjusting the most negative input voltage (0V) to the ideal output code for offset adjustment, and then adjusting the most positive input voltage (5.0V) to its ideal output code for gain adjustment.

Offset Adjustment

The offset adjustment must be completed first. Please refer to Figure 1. Apply an input voltage of 0.5LSB or 610 μ V to any multiplexer input. Adjust the offset potentiometer so that the output code fluctuates evenly between 000...000 and 000...001. It is only necessary to observe the lower eight LSB's during this procedure.

Gain Adjustment

With the offset adjusted, the gain error can now be trimmed to zero. The ideal input voltage corresponding to 1.5 LSB's below the nominal full scale input value, or +4.988V, is applied to any multiplexer input. The gain potentiometer is adjusted so that the output code alternates evenly between 111...111 and 111...110. Again, only the lower eight LSB's need be observed during this procedure. With the above adjustment made, the converter is now calibrated.

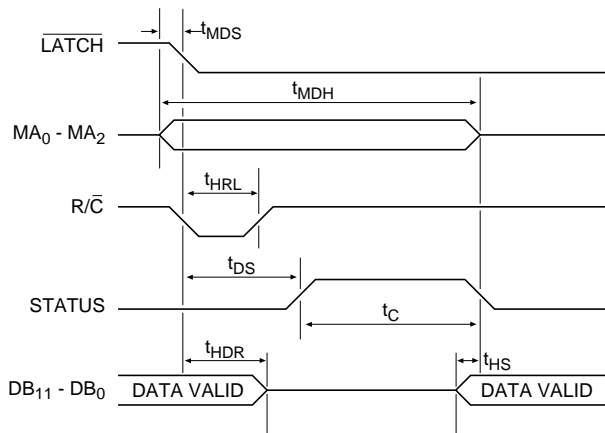

LOW PULSE FOR R/C DYNAMIC CHARACTERISTICS

$V_{CC} = +15V$; $V_{LOGIC} = +5V$; $T_A = 25^\circ C$

PARAMETER	MIN.	TYP.	MAX.	UNIT	CONDITIONS
t_{HRL} Low R/C Pulse Width	50			ns	
t_{DS} Status Delay from R/C			200	ns	
t_{HDR} Data Valid after R/C	25			ns	
t_{HS} Status Delay after Data Valid	500			ns	
t_{MDS} MUX Data Setup	50			ns	
t_{MDH} MUX Data Valid	3		10	μs	

Figure 3. Low Pulse for R/C Timing

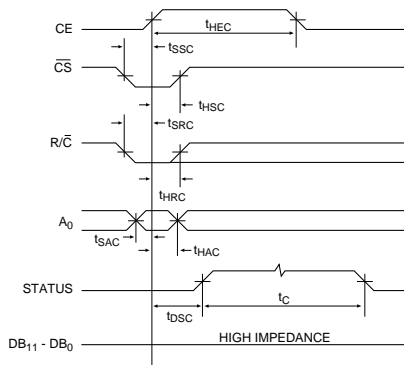

CONVERT MODE DYNAMIC CHARACTERISTICS

$V_{CC} = +15V$; $V_{LOGIC} = +5V$; $T_A = 25^\circ C$

PARAMETER	MIN.	TYP.	MAX.	UNIT	CONDITIONS
t_{HEC} CE Pulse Width	50			ns	
t_{SSC} \overline{CS} to CE Setup	50			ns	
t_{HSC} \overline{CS} Low During CE High	50			ns	
t_{SRC} R/\overline{C} to CE Setup	50			ns	
t_{HRC} R/\overline{C} Low during CE High	50			ns	
t_{SAC} A_0 to CE Setup	0			ns	
t_{HAC} A_0 Valid During CE High	50			ns	
t_{DSC} Status Delay from CE			200	ns	
t_C Conversion Time			10	μs	

Figure 4. Convert Mode Timing

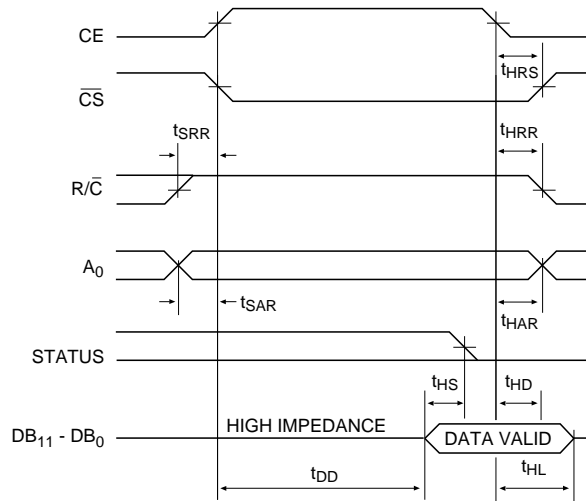

READ MODE DYNAMIC CHARACTERISTICS

$V_{CC} = +15V$; $V_{LOGIC} = +5V$; $T_A = 25^\circ C$

PARAMETER	MIN.	TYP.	MAX.	UNIT	CONDITIONS
t_{HRS}	0	0		ns	\overline{CS} Valid After CE Low
t_{SRR}	50	0		ns	R/ \overline{C} to CE Setup
t_{HRR}	0	50		ns	R/ \overline{C} High After CE Low
t_{SAR}	50			ns	A ₀ to CE Setup
t_{HAR}	50			ns	A ₀ Valid After CE Low
	20			ns	Data Valid After CE Low
t_{DD}			150	ns	Access Time from CE
t_{HL}			150	ns	Output Float Delay

Figure 5. Read Mode Timing

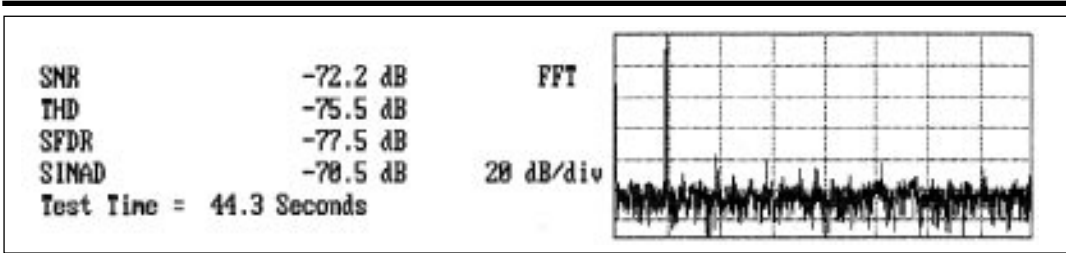

Figure 6. FFT; 6kHz, 5V (0dB) Full Scale Input; $F_s=100\text{kHz}$

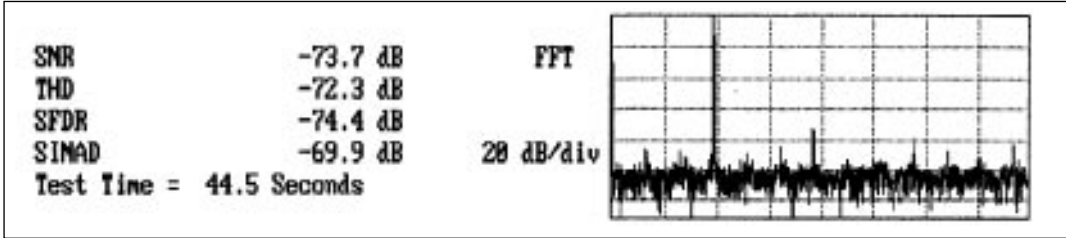

Figure 7. FFT; 12kHz, 5V (0dB) Full Scale Input; $F_s=100\text{kHz}$

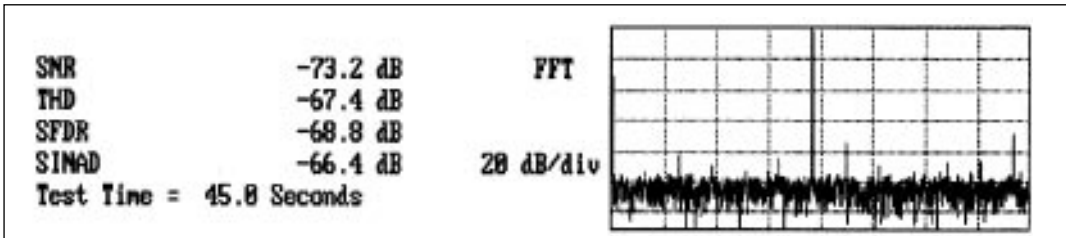

Figure 8. FFT; 24kHz, 5V (0dB) Full Scale Input; $F_s=100\text{kHz}$

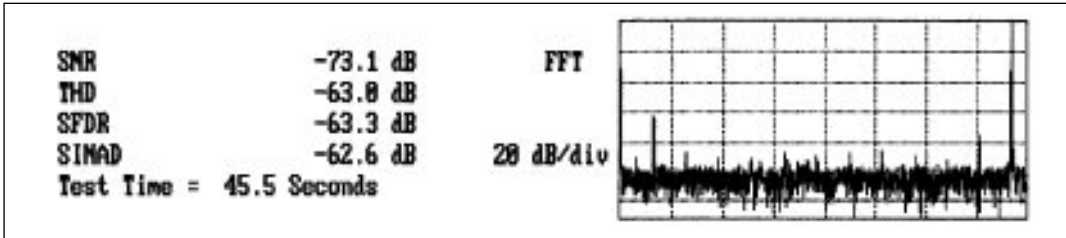

Figure 9. FFT; 48kHz, 5V (0dB) Full Scale Input; $F_s=100\text{kHz}$

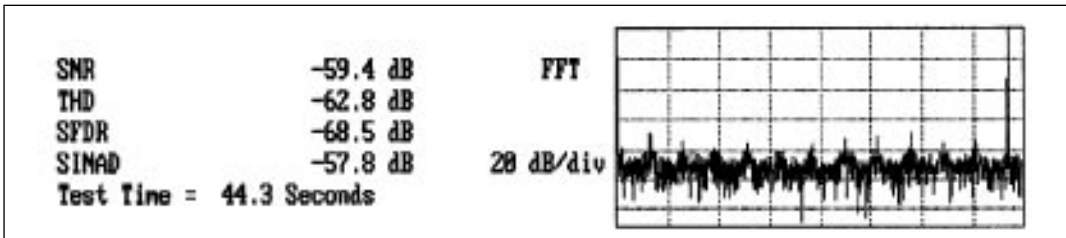

Figure 10. FFT; 48kHz, 1V (-14dB) Input; $F_s=100\text{kHz}$

ORDERING INFORMATION

12-Bit Data Acquisition System, Latched Multiplexer Address,
8-Bit/4-Bit Data Output:

Commercial (0°C to +70°C):	Integral Non-Linearity	Package
SP8481JP	± 1.0 LSB INL	32-pin, 0.6" Plastic DIP
SP8481KP	± 0.5 LSB INL	32-pin, 0.6" Plastic DIP
SP8481JS	± 1.0 LSB INL	32-pin, 0.3" SOIC
SP8481KS	± 0.5 LSB INL	32-pin, 0.3" SOIC
Industrial (-40°C to +85°C):	Integral Non-Linearity	Package
SP8481AP	± 1.0 LSB INL	32-pin, 0.6" Plastic DIP
SP8481BP	± 0.5 LSB INL	32-pin, 0.6" Plastic DIP
SP8481AS	± 1.0 LSB INL	32-pin, 0.3" SOIC
SP8481BS	± 0.5 LSB INL	32-pin, 0.3" SOIC

THIS PAGE LEFT INTENTIONALLY BLANK