

PLEASE CHECK WWW.MOLEX.COM FOR LATEST PART INFORMATION

Part Number: [0002096126](#)
Status: **Active**
Overview: [standard_093](#)
Description: 2.36mm (.093") Diameter, Standard .093" Pin and Socket Crimp Terminal, Series 1380, Male, with Selective Gold (Au) Plated Brass Contact, 18-22 AWG, Bag

Documents:

[Drawing \(PDF\)](#) [RoHS Certificate of Compliance \(PDF\)](#)
[Product Specification PS-02-09 \(PDF\)](#)

General

Product Family	Crimp Terminals
Series	1380
Crimp Quality Equipment	Yes
Overview	standard_093
Product Name	Standard .093"

Physical

Durability (mating cycles max)	25
Gender	Male
Material - Metal	Brass
Material - Plating Mating	Gold
Material - Plating Termination	Gold
Packaging Type	Bag
Plating min: Mating (µin)	50
Plating min: Mating (µm)	1.25
Plating min: Termination (µin)	10
Plating min: Termination (µm)	0.25
Termination Interface: Style	Crimp or Compression
Wire Insulation Diameter	1.52-3.05mm (.060-.120")
Wire Size AWG	18, 20, 22
Wire Size mm ²	N/A

Material Info

Old Part Number	1380-(591)L
-----------------	-------------

Reference - Drawing Numbers

Product Specification	PS-02-09
Sales Drawing	SD-1380-*

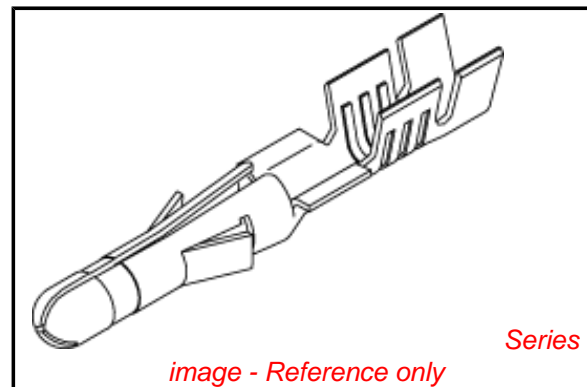

image - Reference only

EU RoHS

**ELV and RoHS
Compliant**
**REACH SVHC
Not Reviewed**
**Halogen-Free
Status**

China RoHS



**Need more information on product
environmental compliance?**

Email productcompliance@molex.com
 For a multiple part number RoHS Certificate of Compliance, [click here](#)

Please visit the [Contact Us](#) section for any non-product compliance questions.

Search Parts in this Series

[1380Series](#)

Application Tooling | [FAQ](#)

Tooling specifications and manuals are found by selecting the products below. Crimp Height Specifications are then contained in the Application Tooling Specification document.

Global

Description	Product #
Hand Crimp Tool	0638191200
Insertion Tool	0011020003
Extraction Tool	0011030006

PART NO.	ENG. NO.
02-09-2118	1380-(P901)L
02-09-2116	1380-(P901)
02-09-2127	1380-(P901)1
02-09-6126	1380-(591)L
02-09-6125	1380-(591)
02-09-6123	1380-(550)L
02-09-6122	1380-(550)
02-09-2119	1380-A(P901)L
02-09-2117	1380-A(P901)

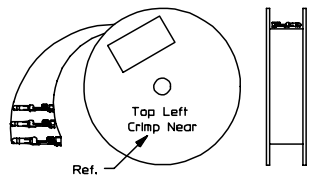

REWOUND CHAIN

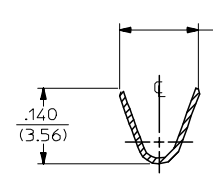
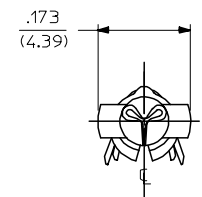

SECT. "A-A"

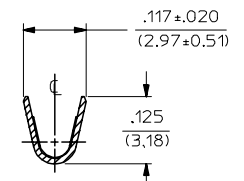

SECT. "B-B"

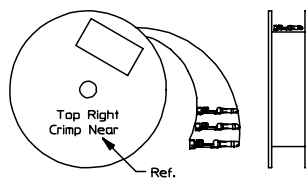

STANDARD CHAIN

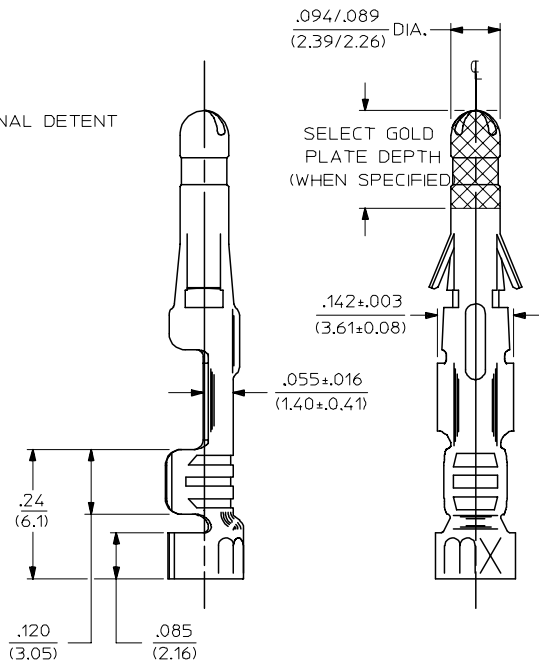
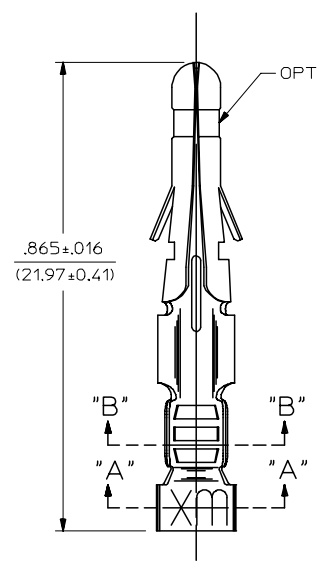

LEGEND

1380-*(***)*
 OPTIONAL DETENT
 BLANK = WITH DETENT
 A = WITHOUT DETENT

FORM
 BLANK = STD. CHAIN
 A = REWOUND CHAIN
 L = LOOSE
 1 = STD. CHAIN WITH INTERLEAF PAPER

P = PREPLATE
 BLANK = POSTPLATE

FINISH CODE
 (SEE NOTE 2)

NOTES:

- MATERIAL: BRASS
- FINISH:
 - 999 UNPLATED
 - 901 HOT TIN DIP .000020/(0.00051) MIN.
 - 591 SELECT GOLD PLATE .000050/(0.00127) MIN. IN CONTACT AREA, OVER .000050/(0.00127) MIN. NICKEL OVERALL WITH .000010/(0.00025) MAX. GOLD FLASH OVERALL.
 - 550 SELECT GOLD PLATE .000015/(0.00038) MIN. IN CONTACT AREA, OVER .000030/(0.00076) MIN. NICKEL OVERALL WITH .000010/(0.00025) MAX. GOLD FLASH OVERALL.
- PRODUCT SPECIFICATION: PS-02-09.
- PACKAGING INFORMATION: NOT AVAILABLE
- TERMINAL FOR USE WITH .093/(2.36) SERIES HOUSINGS AND WILL ACCEPT 18 THRU 22 AWG
- INSERTION FORCE: 3.5 LBS. MAX. WHEN TERMINAL IS INSERTED INTO AN .093 SERIES HOUSING.
- TERMINAL RETENTION: 20 LBS. MIN. FROM HOUSING.

REVISED/REDRAWN EC NO: UCP2004-2354 DRAWN:RHOLTS 2005/07/20 CHKD:FSMITH 2005/07/20 APPR:FSMITH 2005/07/20 BV	QUALITY SYMBOLS	GENERAL TOLERANCES (UNLESS SPECIFIED)	SCALE 6:1	DESIGN UNITS INCH	THIRD ANGLE PROJECTION	REVISE ON CAD ONLY
	DESCRIPTION	mm	DIMENSION STYLE IN/MM		TITLE CRIMP TERMINAL .093 DIA., MALE FOR 18 THRU 22 AWG. WIRE	
		INCH	DRAWN BY DATE GEP 1987/11/06			
		4 PLACES ± --- ± --- 3 PLACES ± --- ± .010 2 PLACES ± 0.25 ± .14 1 PLACE ± 0.35 ± ---	CHECKED BY DATE RW 1987/11/06		APPROVED BY DATE RAS 1987/11/06	
	ANGULAR ±1/2°	DRAFT WHERE APPLICABLE MUST REMAIN WITHIN DIMENSIONS		THIS DRAWING CONTAINS INFORMATION THAT IS PROPRIETARY TO MOLEX INCORPORATED AND SHOULD NOT BE USED WITHOUT WRITTEN PERMISSION		