

The CSM-9 is a compact SMD Crystal. The 8.0 x 4.5 x 1.8 mm ceramic package is ideal for today's SMD manufacturing environment.

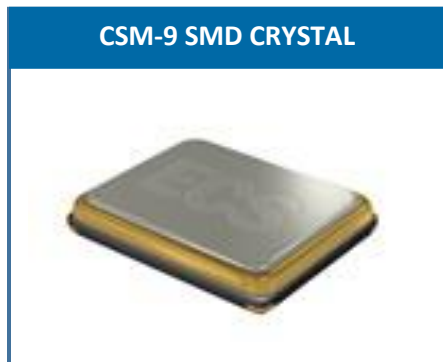

- Low Profile
- 8.0 x 4.5 mm Footprint
- Extended Temp. Range Option
- RoHS Compliant

## OPERATING CONDITIONS / ELECTRICAL CHARACTERISTICS

PARAMETERS	CONDITIONS	CSM-9			UNITS
		MIN	TYP	MAX	
Frequency		4.000		50.000	MHz
Mode of Oscillation	Fundamental				
Frequency Tolerance*	@ +25°C			± 30	ppm
Frequency Stability*	-20 ~ +70°C			± 30	ppm
Shunt Capacitance	Co			5	pF
Load Capacitance	Specify in P/N	8	20	Series	pF
Drive Level	DL			100	μW
Operating Temperature*	T <sub>opr</sub>	-10		+70	°C
Storage Temperature	T <sub>stg</sub>	-55		+125	°C
Aging (First Year)	@ +25°C ±3°C			±5	ppm

## DIMENSIONS (mm)

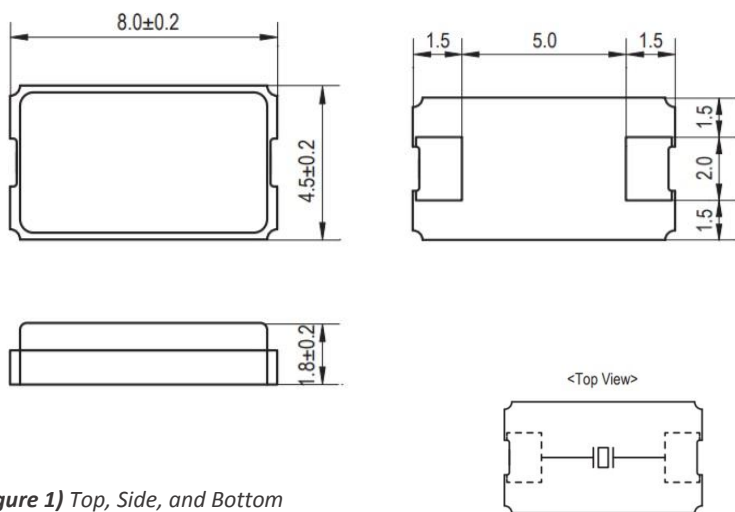

Frequency (MHz)	ESR Ω Max.
4.000 ~ 7.999	300
8.000 ~ 9.999	200
10.000 ~ 11.999	100
12.000 ~ 12.999	80
13.000 ~ 50.000	50

Pad Connections	
1	In/Out
2	Out/In

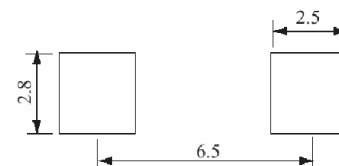

Figure 1) Top, Side, and Bottom

Crystal is symmetrical, pad 1 & 2 are interchangeable. Chamfer on the bottom pad has no electrical significance.

Figure 2) Suggested land

## PART NUMBERING GUIDE: Example ECS-200-20-35-TR

ECS - FREQUENCY ABBREVIATION	LOAD CAPACITANCE	PACKAGE	AVAILABLE OPTIONS			PACKAGING	
			Tolerance	Stability	Temp Range		
ECS	200 = 20.000 MHz See P/N Guide	20 = 20 pF S = Series	35 = CSM-9	Blank = Std A = ± 25 ppm J = ± 20 ppm R = ± 15 ppm C = ± 10 ppm	Blank = Std D = ± 100 ppm E = ± 50 ppm G = ± 30 ppm H = ± 25 ppm T = ± 20 ppm † W = ± 15 ppm † K = ± 10 ppm †	Blank = Std L = -10 ~ +70°C M = -20 ~ +70°C Y = -30 ~ +85°C N = -40 ~ +85°C P = -40 ~ +105°C S = -40 ~ +125°C U = -55 ~ +125°C	TR = Tape & Reel 1K/Reel

\* Specify available options in P/N.

† Contact ECS for availability over extended temp range.

Rev.2017

**POCKET TAPE DIMENSIONS (mm)**

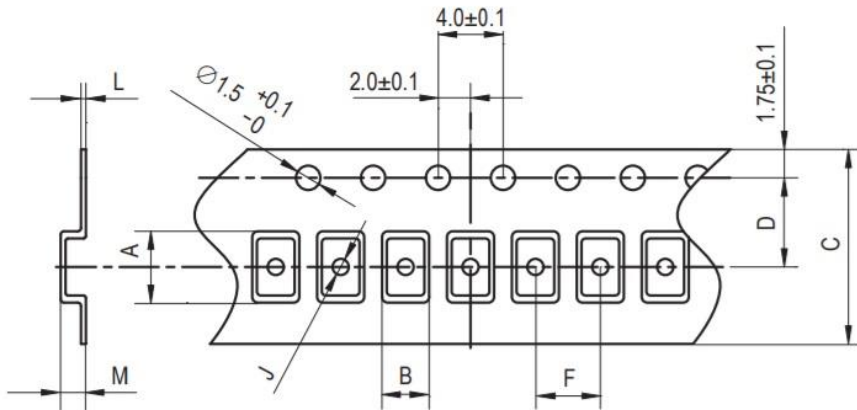

A	B	C	D	F	J	L	M	Reel Dia.	Qty/Reel
8.4	4.8	16.0	7.5	8.0	1.5	0.3	2.0	330	1000pcs

SOLDER PROFILE
Peak solder Temp +260°C Max 10 sec Max.
2 Cycles Max.
MSL 1, Lead Finish Au

DEVELOPED FREQUENCIES	
Abbreviation	Frequency (MHZ)
040	4.000
049	4.91520
080	8.000
081.92	8.912
110.5	11.0592
143	14.31818
184	18.432
200	20.000
283.22	28.322

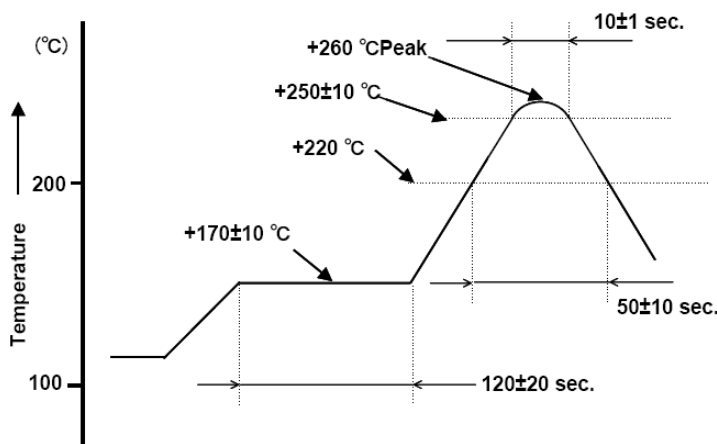

Figure 1) Suggested Reflow Profile