

# 2.5 GHz InGaP HBT 5W Linear Power Amplifier

Mimix  
BROADBAND™

CHV2710-QJ  
RoHS

October 2006 - Rev 23-Oct-06

## Features

- ✕ Internal Pre-matching
- ✕ Single Supply operation, 12V
- ✕ Power Gain 9 dB
- ✕ ESD Protection on board
- ✕ Current Control for multiple applications
- ✕ 2.5% EVM @ 29 dBm avg power, 802.16 OFDM signal format, PAR = 9 dB
- ✕ Low Thermal Resistance
- ✕ Ideal for WiMAX and WiBro applications
- ✕ RoHS compliant 6x6 QFN package



## General Description

The CHV2710 internally pre-matched power HBT device provides 9 dB of gain, 2.5% EVM at 29 dBm output power for 802.16 OFDM signal with a peak to average power ratio of 9 dB. The device operates off a single supply voltage up to 12V and includes internal bias circuitry to enable exact setting of the quiescent current using an external Vcontrol. This Vcontrol is non-unique voltage setting and the same value can be used for each part depending on the required Icq. The device is ideal for high linearity, high data rate applications such as WiMAX and WiBro. Internal pre-matching facilitates a simplified external matching approach and the highest in-band gain potential of the device. The device operates with unique matching at each of the popular WiMAX bands with the inherent repeatability of an InGaP HBT process.

## Absolute Maximum Ratings

Voltage Supply (Vcc)	4.5 (min) / 12 V (max)
Current (Icc)	2000 mA
Dissipated Power (P <sub>diss</sub> )	18W
Input Power (P <sub>in</sub> )	22 dBm
Storage Temperature (T <sub>stg</sub> )	-60 to +150 °C
Channel Temperature (T <sub>ch</sub> )	175 °C
Thermal Resistance (R <sub>th</sub> )	5 °C/W
Operating Backside Temperature (T <sub>b</sub> )	-40 °C to (see note 1)

Operation outside any of these limits can cause permanent damage.  
(1) Calculate maximum operating temperature T<sub>max</sub> using the following formula: T<sub>max</sub>=175-(P<sub>diss</sub> [W] x 5) [C].

## Electrical Characteristics (Ambient Temperature T=25 °C, Vcc=12V)<sup>1</sup>

Parameter	Units	CHV2710-QJ-0G00 (WiMAX 2.5 GHz)			CHV2710-QJ-0GA0 (WiBro 2.3 GHz)		
		Min.	Typ.	Max.	Min.	Typ.	Max.
Operating Frequency (f)	GHz	2.5	2.6	2.7	2.3	2.35	2.4
Quiescent Current <sup>2</sup> (I <sub>cc</sub> )	mA	-	730	760	-	730	760
Power Gain @ P <sub>out</sub> = 29 dBm (G <sub>ps</sub> )	dB	-	9	-	-	10	-
Current @ 29 dBm (I <sub>cc</sub> )	mA	-	770	800	-	770	800
Output Power @ EVM = 2.5% <sup>3</sup>	dBm	29	-	-	29	-	-
Adjacent Channel Power Ratio @ P <sub>out</sub> = 29 dBm <sup>4</sup> (ACPR)	dBc	-	-45	-	-	-45	-
Input Reflection Coefficient (S <sub>11</sub> )	dB		-12			-12	
Noise Figure (NF)	dB		4			4	

1. Data measured in a Mimix matched connectorized fixture.
2. Quiescent current depends on Vcc
3. Using an 802.16d OFDM signal format with PAR=9 dB
4. Using 3 GPP WCDMA signal, PAR = 9.17 dB

Mimix Broadband, Inc., 10795 Rockley Rd., Houston, Texas 77099  
Tel: 281.988.4600 Fax: 281.988.4615 mimixbroadband.com

Page 1 of 7

Characteristic Data and Specifications are subject to change without notice. ©2006 Mimix Broadband, Inc.  
Export of this item may require appropriate export licensing from the U.S. Government. In purchasing these parts, U.S. Domestic customers accept their obligation to be compliant with U.S. Export Laws.

# 2.5 GHz InGaP HBT 5W Linear Power Amplifier

October 2006 - Rev 23-Oct-06

CHV2710-QJ  
RoHS

## Typical Performance: CHV2710-QJ-0G00 (WiMAX 2.5 GHz) (802.16 OFDM signal, PAR = 9 dB, Vcc = 12V, Vcontrol = 8V, Icc = 736mA)

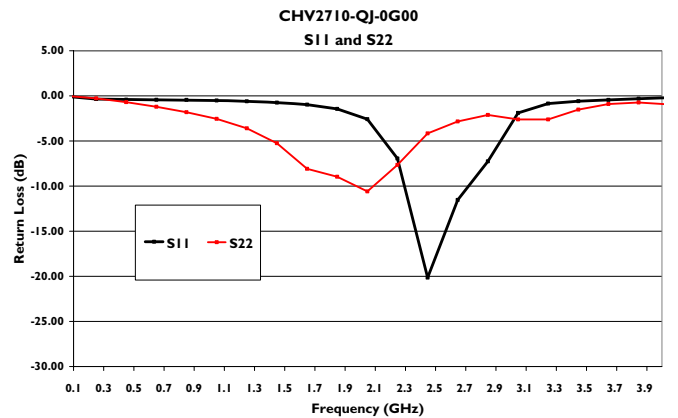
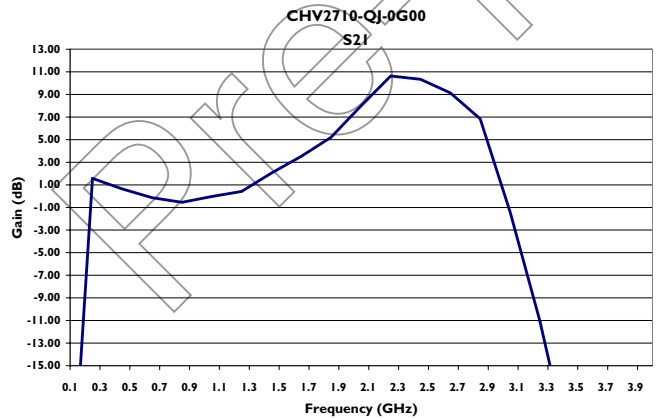
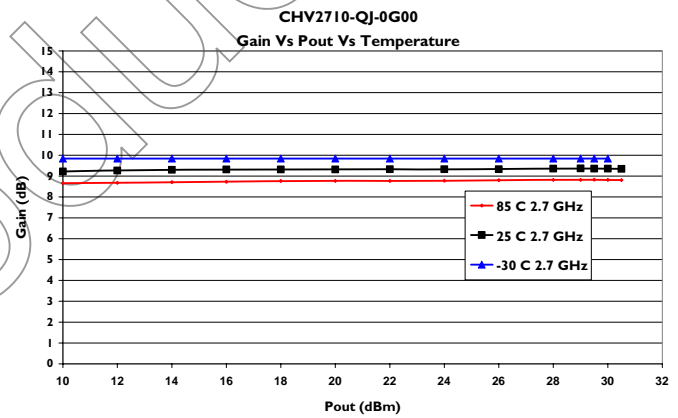
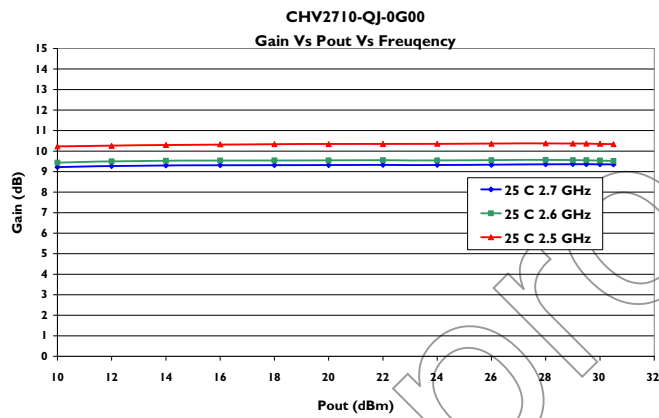
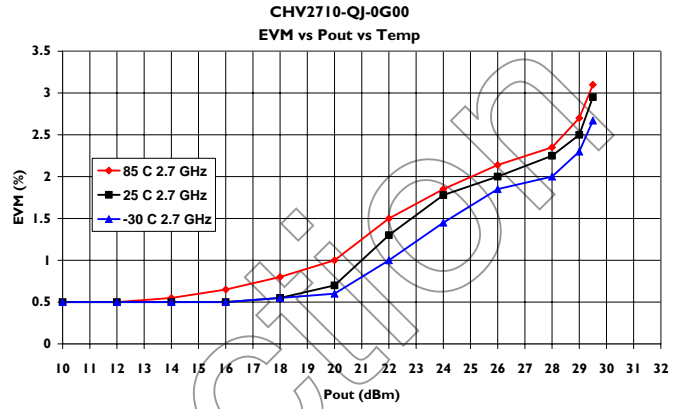
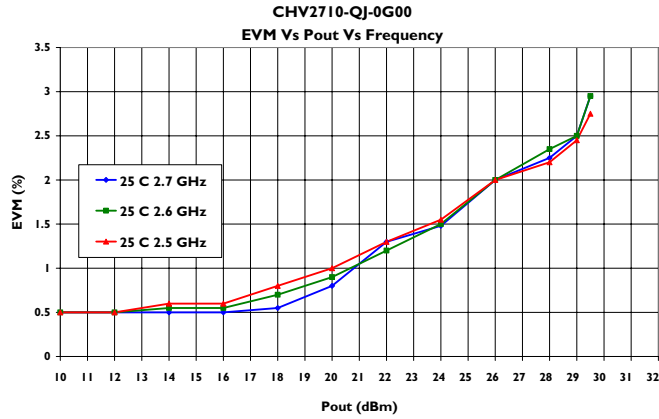

# 2.5 GHz InGaP HBT 5W Linear Power Amplifier

October 2006 - Rev 23-Oct-06

CHV2710-QJ  
RoHS

## Typical Performance: CHV2710-QJ-0GA0 (WiBro) (3 GPP WCDMA, PAR = 9.17 dB)

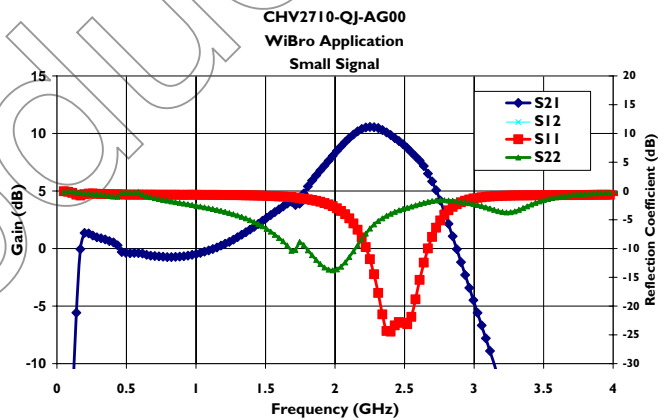
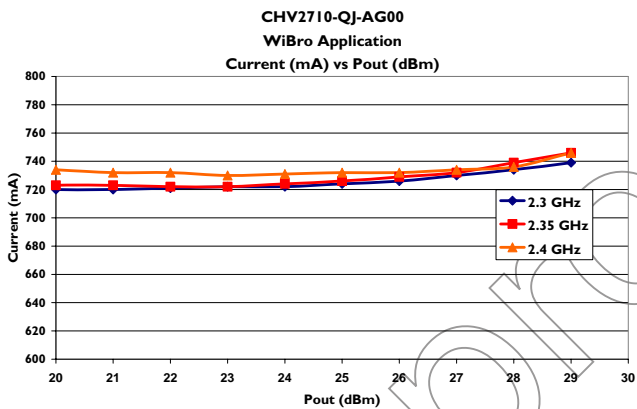
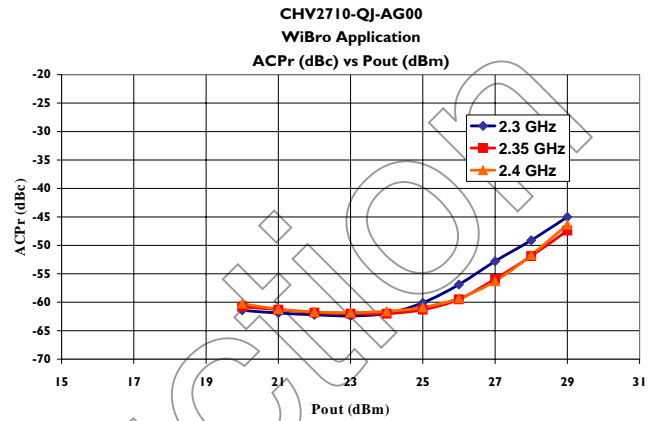
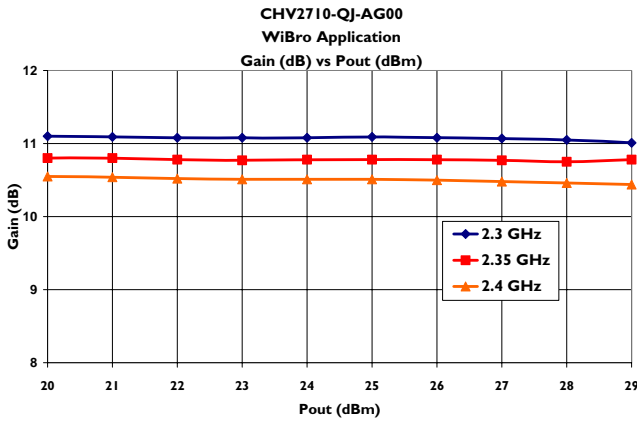

# 2.5 GHz InGaP HBT 5W Linear Power Amplifier

October 2006 - Rev 23-Oct-06

CHV2710-Q  
RoHS

## Recommended Board Schematic for WiMAX 2.5 GHz

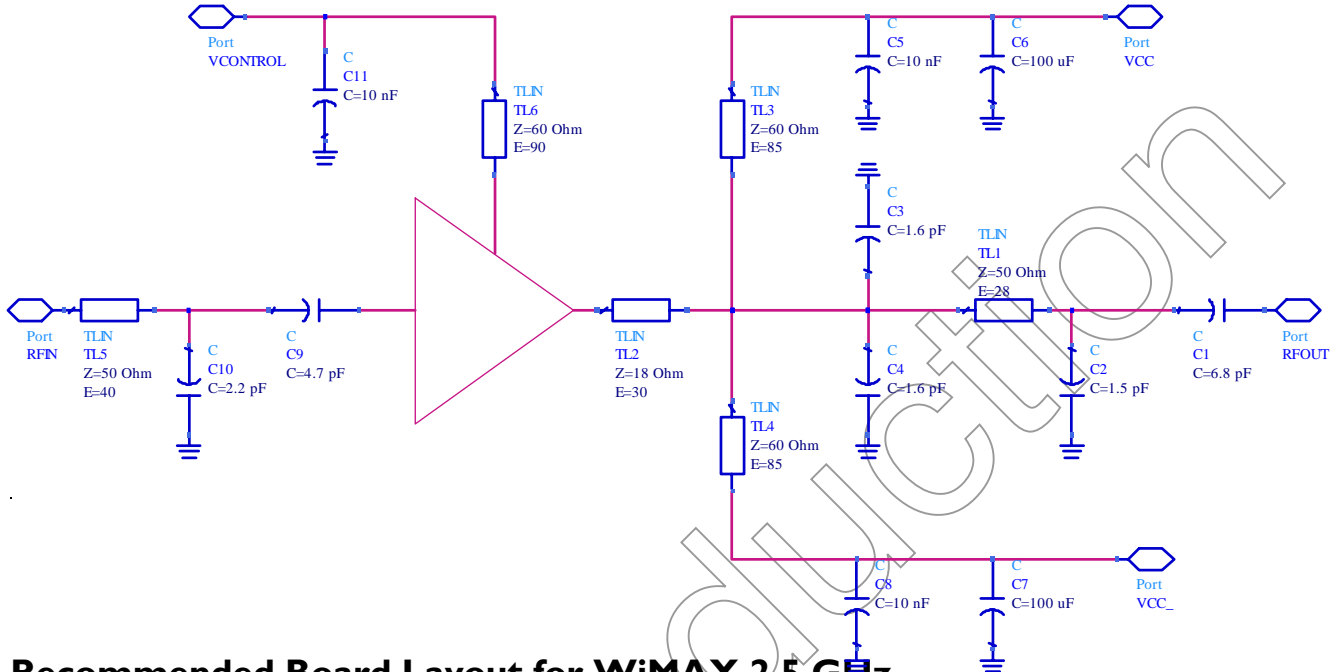

## Recommended Board Layout for WiMAX 2.5 GHz

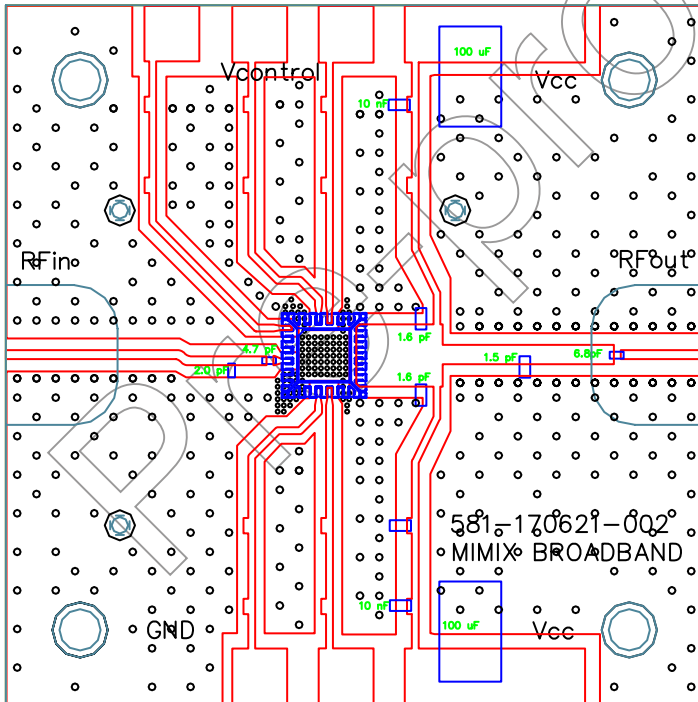

12 mil RO4003

Ident.	Description
C1	Murata 0603 ERB 1.6 pF
C2	Murata 0603 ERB 1.5 pF
C3	Murata 0603 ERB 6.8 pF
C4	Murata 0603 ERB 4.7 pF
C5	Murata 0603 ERB 2.0 pF
C6	10 uF
C7	100 uF

# 2.5 GHz InGaP HBT 5W Linear Power Amplifier

## Recommended Board Layout:

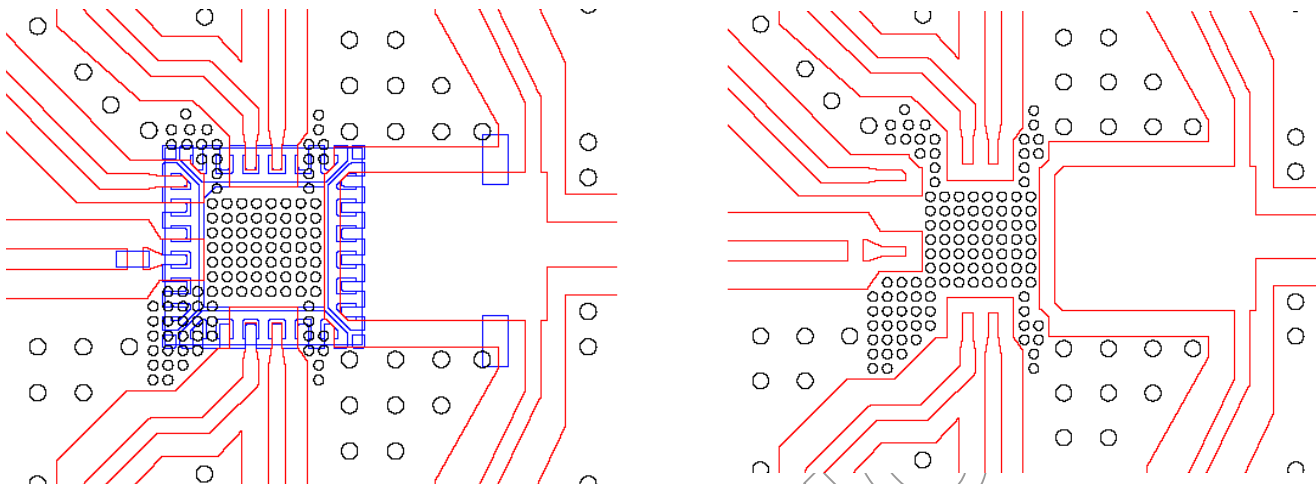

We recommend that all N/C pins be grounded and sufficient number of vias to be present under the ground plane to insure good RF and thermal grounding. Pins 13 and 18 are connected to the RFout trace.

## Physical Dimensions:

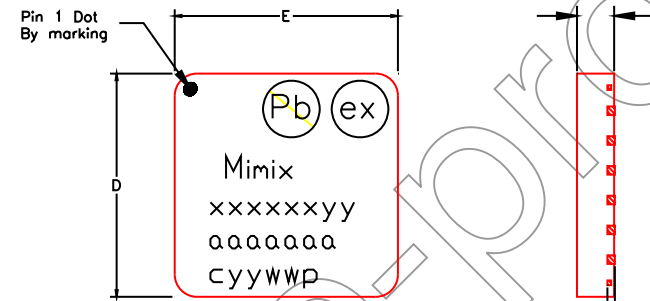

TOP VIEW

RECOMMENDED SOLDER PAD PITCH AND DIMENSIONS

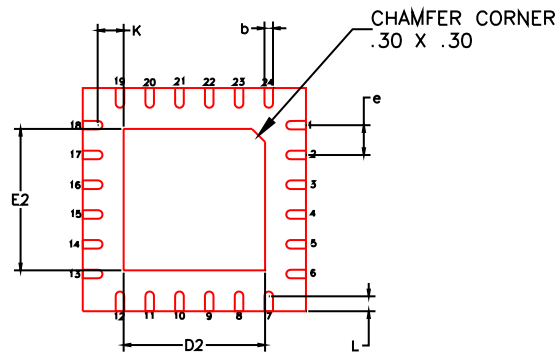

BOTTOM VIEW

Note:

1. ALL DIMENSIONS ARE IN mm.

	MIN	TYP	MAX
A	.85	.90	.95
A3		0.203	REF
b	0.18	0.23	0.28
K	0.50	-	-
D		6.00	BSC
E		6.00	BSC
e		0.80	
D2	3.70	3.80	3.90
E2	3.70	3.80	3.90
L	0.35	0.40	0.45

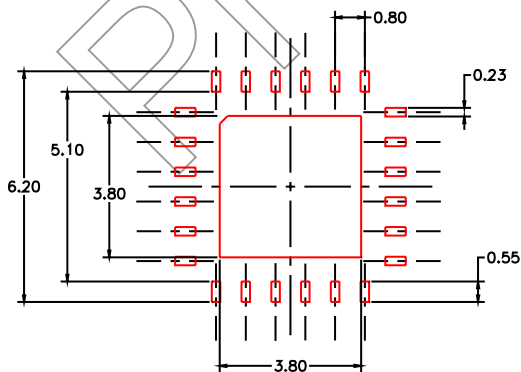

# 2.5 GHz InGaP HBT 5W Linear Power Amplifier

October 2006 - Rev 23-Oct-06

CHV2710-Q  
RoHS

## Pin Assignment:

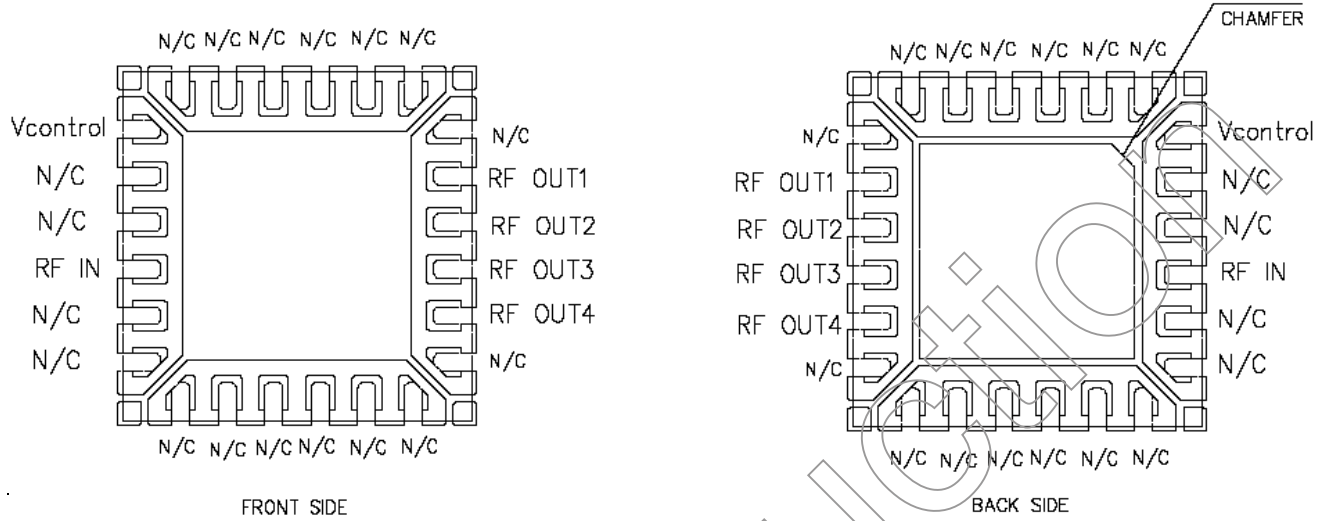

## Functional Block Diagram:

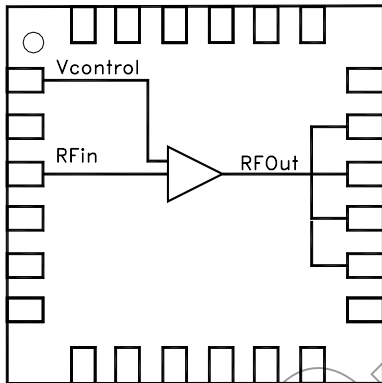

Pin #	Description
1	Vcontrol
4	RF IN
14	RF OUT 4
15	RF OUT 3
16	RF OUT 2
17	RF OUT 1
2, 3, 5, 6, 7, 8, 9, 10, 11, 12 13, 18, 19, 20, 21, 22, 23, 24	N/C

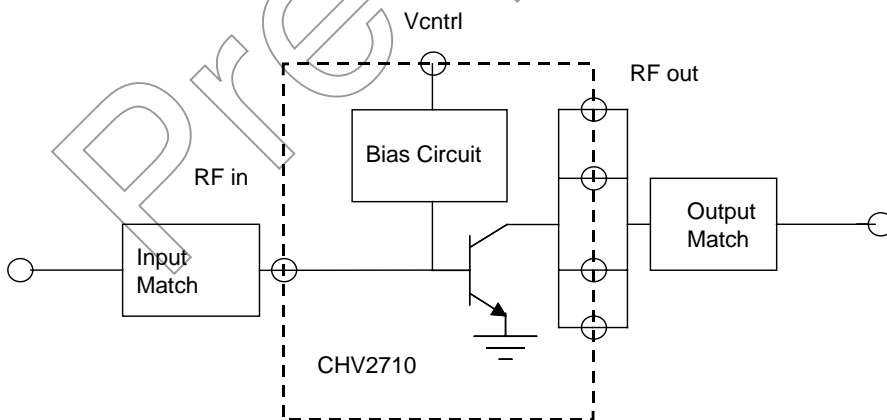

\* Backside of Package is emitter gnded

# 2.5 GHz InGaP HBT 5W Linear Power Amplifier

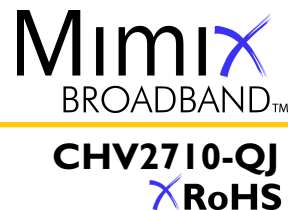

October 2006 - Rev 23-Oct-06

## Handling and Assembly Information

**CAUTION!** - Mimix Broadband MMIC Products contain gallium arsenide (GaAs) which can be hazardous to the human body and the environment. For safety, observe the following procedures:

- Do not ingest.
- Do not alter the form of this product into a gas, powder, or liquid through burning, crushing, or chemical processing as these by-products are dangerous to the human body if inhaled, ingested, or swallowed.
- Observe government laws and company regulations when discarding this product. This product must be discarded in accordance with methods specified by applicable hazardous waste procedures.

**Life Support Policy** - Mimix Broadband's products are not authorized for use as critical components in life support devices or systems without the express written approval of the President and General Counsel of Mimix Broadband. As used herein: (1) Life support devices or systems are devices or systems which, (a) are intended for surgical implant into the body, or (b) support or sustain life, and whose failure to perform when properly used in accordance with instructions for use provided in the labeling, can be reasonably expected to result in a significant injury to the user. (2) A critical component is any component of a life support device or system whose failure to perform can be reasonably expected to cause the failure of the life support device or system, or to affect its safety or effectiveness.

**Package Attachment** - This packaged product from Mimix Broadband is provided as a rugged surface mount package compatible with high volume solder installation. Care should be taken not to apply heavy pressure to the top or base material to avoid package damage. Vacuum tools or other suitable pick and place equipment may be used to pick and place this part. Care should be taken to ensure that there are no voids or gaps in the solder connection so that good RF, DC and ground connections are maintained. Voids or gaps can eventually lead not only to RF performance degradation, but reduced reliability and life of the product due to thermal stress.

**Mimix Lead-Free RoHS Compliant Program** - Mimix has an active program in place to meet customer and governmental requirements for eliminating lead (Pb) and other environmentally hazardous materials from our products. All Mimix RoHS compliant components are form, fit and functional replacements for their non-RoHS equivalents. Lead plating of our RoHS compliant parts is 100% matt tin (Sn) over copper alloy and is backwards compatible with current standard SnPb low-temperature reflow processes as well as higher temperature (260°C reflow) "Pb Free" processes.

## Ordering Information

Part Number	Description
CHV2710-QJ-0G00	Matte Tin plated RoHS compliant 6X6 QFN surface mount package in bulk tested for WiMAX 2.5 GHz
CHV2710-QJ-0G0T	Matte Tin Plated RoHS compliant 6X6 QFN surface mount package in tape and reel tested for WiMAX 2.5 GHz
CHV2710-QJ-0GA0	Matte Tin plated RoHS compliant 6X6 QFN surface mount package in bulk tested for WiBRO
CHV2710-QJ-0GAT	Matte Tin Plated RoHS compliant 6X6 QFN surface mount package in tape and reel tested for WiBRO
PB-CHV2710-0000	Evaluation Board with SMA connectors for WiMAX 2.5 GHz
PB-CHV2710-00A0	Evaluation Board with SMA connectors for WiBRO

We also offer the plastic package with SnPb (Tin-Lead) or NiPdAu plating. Please contact your regional sales manager for more information regarding different plating types.

Mimix Broadband, Inc., 10795 Rockley Rd., Houston, Texas 77099  
Tel: 281.988.4600 Fax: 281.988.4615 [mimixbroadband.com](http://mimixbroadband.com)

Page 7 of 7

Characteristic Data and Specifications are subject to change without notice. ©2006 Mimix Broadband, Inc.  
Export of this item may require appropriate export licensing from the U.S. Government. In purchasing these parts, U.S. Domestic customers accept their obligation to be compliant with U.S. Export Laws.