

SWITCH FUNCTION	
POS. 1	POS. 2
OFF	(ON)
OPEN	1-2

(ON) = MOMENTARY

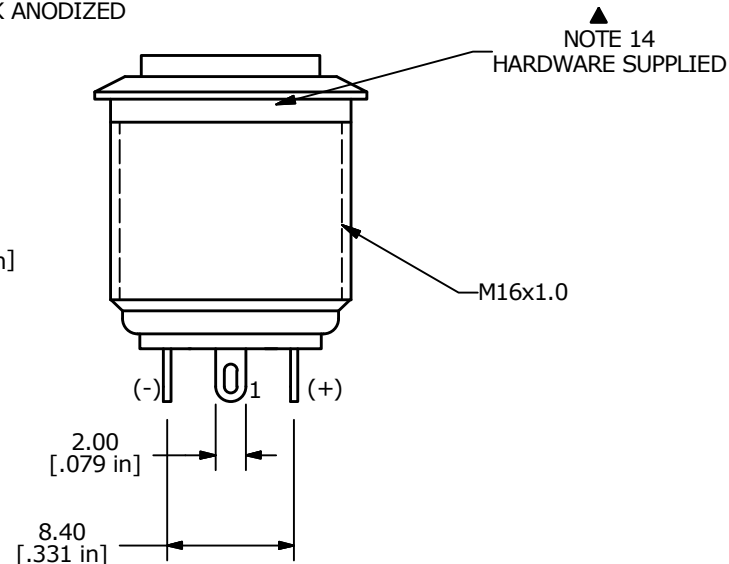

- NOTE:
- ALL DIMENSIONS IN MM [INCH]
  - GENERAL TOLERANCE: X.X=±0.4 X.XX=±0.25
  - TERMINAL NUMBERS FOR REF ONLY
  - CONTACT MATERIAL: SILVER PLATED
  - RATING: 2A 48VDC
  - ELECTRIC LIFE: 200,000 MAKE-AND-BREAK CYCLES AT FULL LOAD.
  - INSULATION RESISTANCE: 1,000 MΩ MIN.
  - DIELECTRIC STRENGTH: 2,000 VAC MIN. FOR 1 MINUTE
  - CONTACT RESISTANCE: 50mΩ MAX. @ 1A 12VDC
  - OPERATING TEMP.: -20°C to 55°C
  - TRAVEL: 1.8mm
  - ▲ DENOTES CRITICAL PARAMETER.
  - ILLUMINATION COLOR: RED
  - HARDWARE SUPPLIED: O-RING AND HEXNUT (NOT SHOWN)
  - ILLUMINATION BASE RATING: 20mA 1.8V
  - 2002/95/EC (ROHS) COMPLIANT

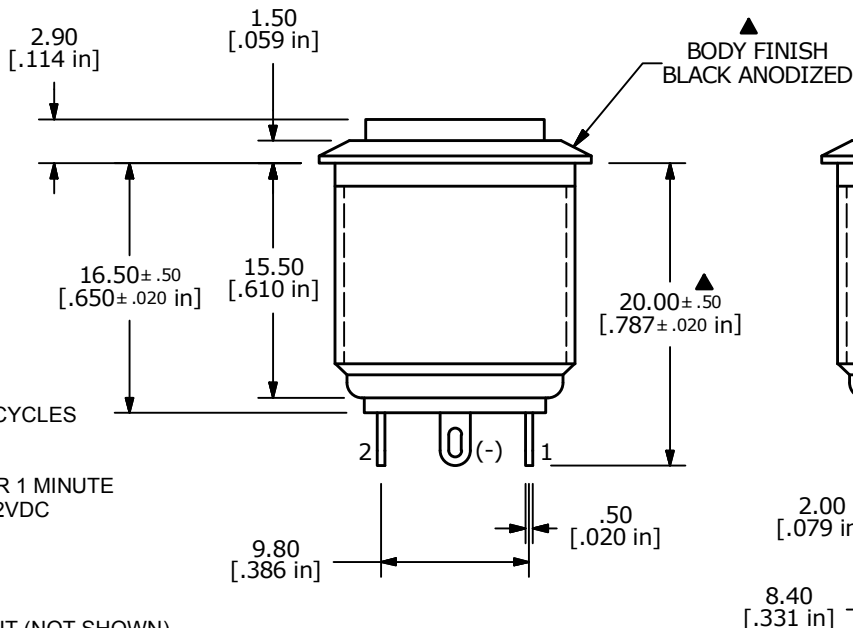
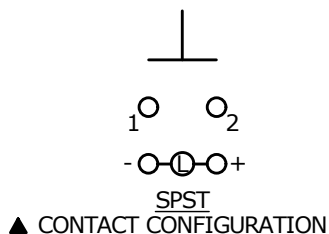
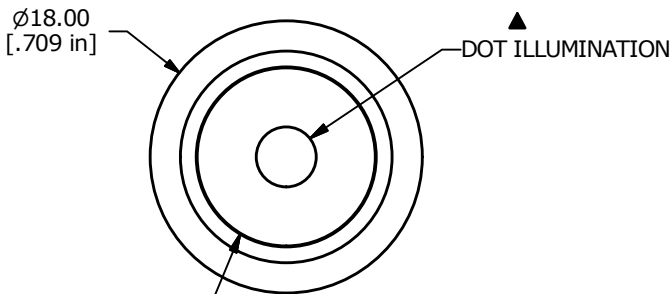

TITLE PV6H24011-211

A	21794	RELEASE FOR PRODUCTION	3/4/15	MW
REV	PCR NO	DESCRIPTION	DATE	BY

THE INFORMATION CONTAINED IN THIS DOCUMENT IS PROPRIETARY TO E-SWITCH AND IS NOT TO BE COPIED OR TRANSFERRED

SCALE 2:1	DATE 3/4/2015	DR MW	DWG 52-PV6H24011211	REV A
-----------	---------------	-------	---------------------	-------