

# APPROVAL SHEET

**MR18X, MR20X, MR25X**

**±1%, ±5%**

Power chip resistors

Size 1218, 2010, 2512

( Automotive & Anti-sulfuration )

\*Contents in this sheet are subject to change without prior notice.

## FEATURE

1. High power rating and compact size
2. High reliability and stability
3. Automotive AEC Q-200 compliant
4. 100% CCD visual inspection
5. RoHS compliant and Lead free product

## APPLICATION

- Power supply
- Industry
- Motor control
- M/B Computer
- Automotives
- Servo

## DESCRIPTION

The resistors are constructed in a high grade ceramic body (aluminum oxide). Internal metal electrodes are added at each end and connected by a resistive paste that is applied to the top surface of the substrate. The composition of the paste is adjusted to give the approximate resistance required and the value is trimmed to nominated value within tolerance which controlled by laser trimming of this resistive layer.

The resistive layer is covered with a protective coat. Finally, the two external end terminations are added. For ease of soldering the outer layer of these end terminations is a Tin (lead free) alloy.

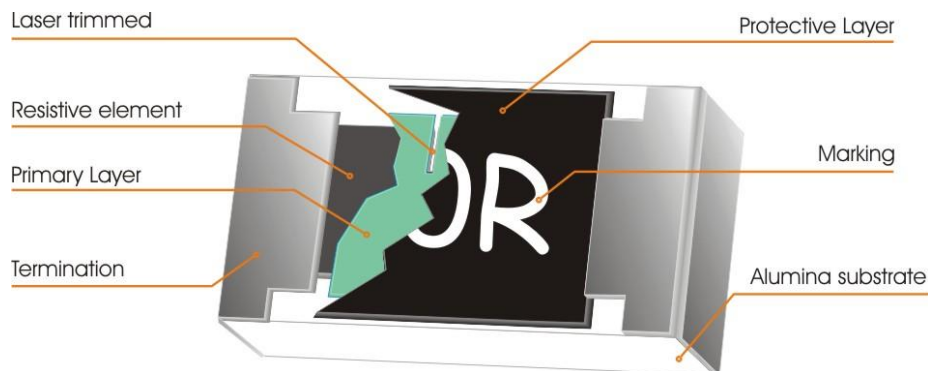

Fig 1. Construction of 2512, 2010 Chip-R

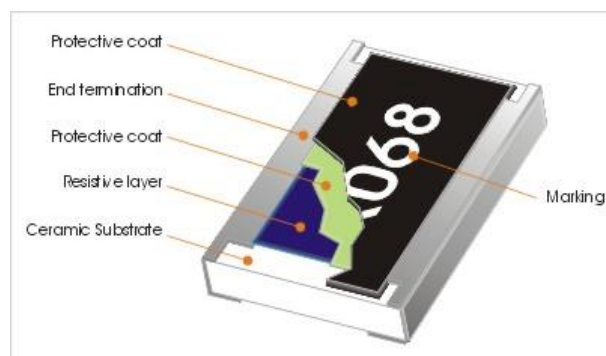

Fig 2. Construction of 1218 Chip-R

**QUICK REFERENCE DATA**

Item	General Specification		
Series No.	MR18	MR20	MR25
Size code	1218(3248)	2010 ( 5025 ),	2512(6432)
Resistance Tolerance	±5% (E24); ±1% (E24+E96)		
Resistance Range	1Ω ~ 10MΩ, Jumper (0Ω)		
TCR (ppm/°C)	< 10Ω	± 200 ppm/°C	± 200 ppm/°C
	10Ω ~ 1MΩ	± 100 ppm/°C	± 100 ppm/°C
	> 1MΩ	± 200 ppm/°C	± 200 ppm/°C
Max. dissipation at T <sub>amb</sub> =70°C	1W	0.75 W	1W
Max. Operation Voltage (DC or RMS)	200V	200V	250V
Max. Overload Voltage (DC or RMS)	400V	400V	500V
Climatic category (IEC 60068)	55/155/56		

Test conditions for jumper ( 0 ohm )

Type	MR18X	MR20X	MR25X
Power Rating At 70C	1 W	3/4 W	1 W
Resistance	Max. 50mR	Max. 50mR	Max. 50mR
Rated Current	4.5 A	3.2 A	4.5 A
Peak Current	11 A	8 A	11 A
Operating Temperature	-55C ~ 155°C		

Note :

1. This is the maximum voltage that may be continuously supplied to the resistor element, see "IEC publication 60115-8"
2. Max. Operation Voltage : So called RCWV (Rated Continuous Working Voltage) is determined by

$$RCWV = \sqrt{\text{Rated Power} \times \text{Resistance Value}} \text{ or Max. RCWV listed above, whichever is lower.}$$

**MECHANICAL DATA (unit : mm)**

TYPE	MR18	MR20	MR25
L	3.05±0.15	5.00±0.20	6.40±0.20
W	4.60±0.20	2.50±0.20	3.20±0.20
T	0.55±0.10	0.55±0.10	0.60±0.10
Tt	0.45±0.25	0.65±0.25	0.65±0.25
Tb	0.50±0.25	0.60±0.25	0.90±0.25

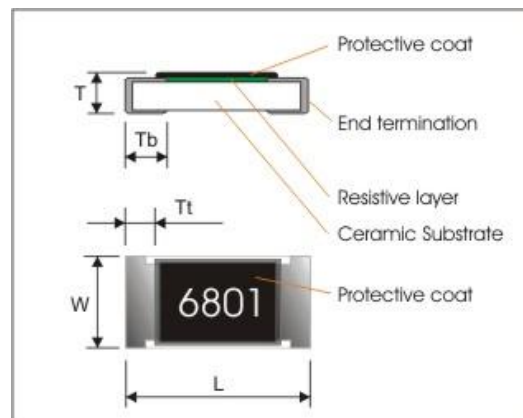

### MARKING

Each resistor is marked with a four-digit code on the protective coating to designate the nominal resistance value  $\pm 5\%$ ,  $\pm 1\%$  tolerance !

Size	$\pm 5\%$	$\pm 1\%$
2512, 2010, 1218	4-digits marking	4-digits marking

### FUNCTIONAL DESCRIPTION

#### Product characterization

Standard values of nominal resistance are taken from the E96 & E24 series for resistors with a tolerance of  $\pm 5\%$  &  $\pm 1\%$ . The values of the E24/E96 series are in accordance with "IEC publication 60063".

#### Derating curve

The power that the resistor can dissipate depends on the operating temperature; see Fig.3

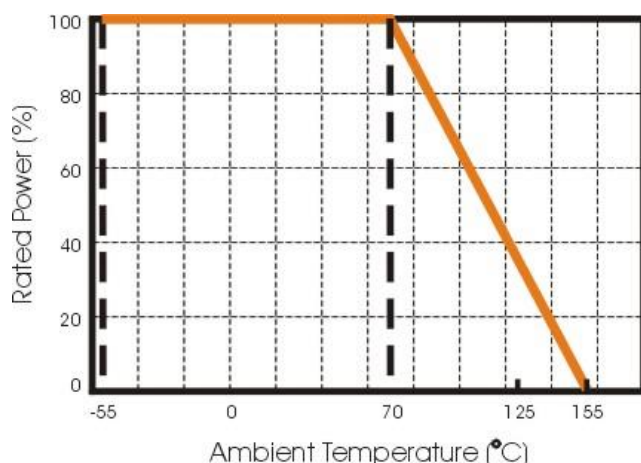

Fig 3 Maximum dissipation in percentage of rated power as a function of the ambient temperature

### MOUNTING

Due to their rectangular shapes and small tolerances, Surface Mountable Resistors are suitable for handling by automatic placement systems. Chip placement can be on ceramic substrates and printed-circuit boards (PCBs). Electrical connection to the circuit is by individual soldering condition. The end terminations guarantee a reliable contact.

### SOLDERING CONDITION

The robust construction of chip resistors allows them to be completely immersed in a solder bath of 260°C for 10 seconds. Therefore, it is possible to mount Surface Mount Resistors on one side of a PCB and other discrete components on the reverse (mixed PCBs).

Surface Mount Resistors are tested for solderability at 235°C during 2 seconds. The test condition for no leaching is 260°C for 30 seconds. Typical examples of soldering processes that provide reliable joints without any damage are given in Fig 4.

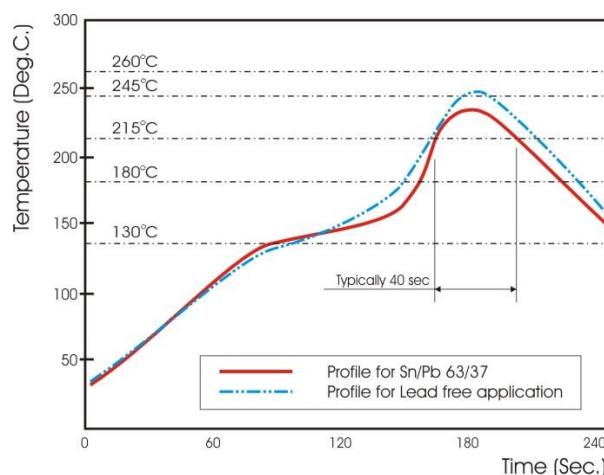

Fig 4. Infrared soldering profile for Chip Resistors

## CATALOGUE NUMBERS

The resistors have a catalogue number starting with .

MR25	X	472_	J	T	L
<b>Size code</b>	<b>Type code</b>	<b>Resistance code</b>	<b>Tolerance</b>	<b>Packaging code</b>	<b>Termination code</b>
MR25 : 2512	X :	±5%: E24: 2 significant digits followed by no. of zeros	F : ±1%	T : 7" Reeled taping	L = Sn base (lead free)
MR20 : 2010	±5%: 1Ω-10MΩ	100Ω = 101_	J : ±5%	Q : 10" Reeled taping	
MR18 : 1218	±1%: 10Ω-1MΩ	10KΩ = 103	P : Jumper	G : 13" Reeled taping	
	W :	±11%: E96: 3 significant digits followed by no. of zeros		B : Bulk	
	±1%: < 10Ω; >1MΩ	102Ω =1020			
		37.4KΩ =3742			

\* Anti-Sulfuration test conditions: H2S 3ppm, 40°C, RH 90%, 1000hrs, criteria: +/-1% !

\* 100% CCD visual inspection to guarantee visual quality !

## TEST AND REQUIREMENTS

Essentially all tests are carried out according to the schedule of IEC publication 115-8, category **LCT/UCT/56**(rated temperature range : **L**ower **C**ategory **T**emperature, **U**pper **C**ategory **T**emperature; damp heat, long term, 56 days). The testing also meets the requirements specified by EIA, EIAJ and JIS.

The tests are carried out in accordance with IEC publication 68, "Recommended basic climatic and mechanical robustness testing procedure for electronic components" and under standard atmospheric conditions according to IEC 60068-1, subclause 5.3. Unless otherwise specified, the following value supplied :

Temperature: 15°C to 35°C.

Relative humidity: 45% to 75%.

Air pressure: 86kPa to 106 kPa (860 mbar to 1060 mbar).

All soldering tests are performed with mildly activated flux.

TEST	PROCEDURE / TEST METHOD	REQUIREMENT	
		Resistor	0Ω
Electrical Characteristics <b>JISC5201-1: 1998</b> Clause 4.8	- DC resistance values measurement - Temperature Coefficient of Resistance (T.C.R) Natural resistance change per change in degree centigrade. $\frac{R_2 - R_1}{R_1(t_2 - t_1)} \times 10^6 \text{ (ppm/°C)} \quad t_1 : 20^\circ\text{C}+5^\circ\text{C}-1^\circ\text{C}$ R <sub>1</sub> : Resistance at reference temperature R <sub>2</sub> : Resistance at test temperature	Within the specified tolerance Refer to "QUICK REFERENCE DATA"	
Resistance to soldering heat (R.S.H) <b>MIL-STD-202 method 210</b>	Un-mounted chips completely immersed for 10±1second in a SAC solder bath at 270°C ±5°C	ΔR/R max. ±(0.5%+0.05Ω) No visible damage	

TEST	PROCEDURE / TEST METHOD	REQUIREMENT	
		Resistor	0Ω
Solderability <b>J-STD-002</b>	a) Bake the sample for 155°C dwell time 4hrs/ solder dipping 235°C/ 5sec. b) Steam the sample dwell time 1 hour/ solder dipping 260°C/ 7sec.	95% coverage min., good tinning and no visible damage	
Temperature cycling <b>JESD22</b> <b>Method JA-104</b>	1000 cycles, -55°C ~ +155°C, dwell time 5~10min	ΔR/R max. ±(0.5%+0.05Ω) No visible damage	<50mΩ
Moisture Resistance <b>MIL-STD-202</b> <b>method 106</b>	65±2°C, 80~100% RH, 10 cycles, 24 hours/ cycle	ΔR/R max. ±(0.5%+0.05Ω) No visible damage	<50mΩ
Bias Humidity <b>MIL-STD-202</b> <b>method 103</b>	1000+48/-0 hours; 85°C, 85% RH, 10% of operation power	ΔR/R max. ±(1.0%+0.05Ω) No visible damage	<50mΩ
Operational Life <b>MIL-STD-202</b> <b>method 108</b>	1000+48/-0 hours; 35% of operation power, 125±2°C	ΔR/R max. ±(1%+0.05Ω) No visible damage	<50mΩ
High Temperature Exposure <b>MIL-STD-202</b> <b>Method 108</b>	1000+48/-0 hours; without load in a temperature chamber controlled 155±3°C	ΔR/R max. ±(1.0%+0.05Ω) No visible damage	<50mΩ
Mechanical Shock <b>MIL-STD-202</b> <b>method 213</b>	1/2 Sine Pulse / 1500g Peak / Velocity 15.4ft/sec	Within the specified tolerance No visible damage	<50mΩ
Board Flex <b>AEC-Q200-005</b>	Resistors mounted on a 90mm glass epoxy resin PCB(FR4), bending once 2mm for 10sec	ΔR/R max. ±(1.0%+0.05Ω). No visible damage	<50mΩ
Terminal strength <b>AEC-Q200-006</b>	Pressurizing force: 1.8Kg, Test time: 60±1sec.	No remarkable damage or removal of the terminations	
Vibration <b>MIL-STD-202</b> <b>method 204</b>	Test 5g's for 20min., 12 cycles each of 3 orientations	ΔR/R max. ±(1.0%+0.05Ω) No visible damage	<50mΩ
Thermal shock <b>MIL-STD-202</b> <b>method 107</b>	Test -55 to 155°C / dwell time 15min/ Max transfer time 20sec 300cycles	ΔR/R max. ±(0.5%+0.05Ω) No visible damage	<50mΩ
ESD <b>AEC-Q200-002</b>	Test contact 3.0KV	ΔR/R max. ±(1.0%+0.05Ω). No visible damage	<50mΩ

**PACKAGING**

Plastic Tape specifications (unit :mm)

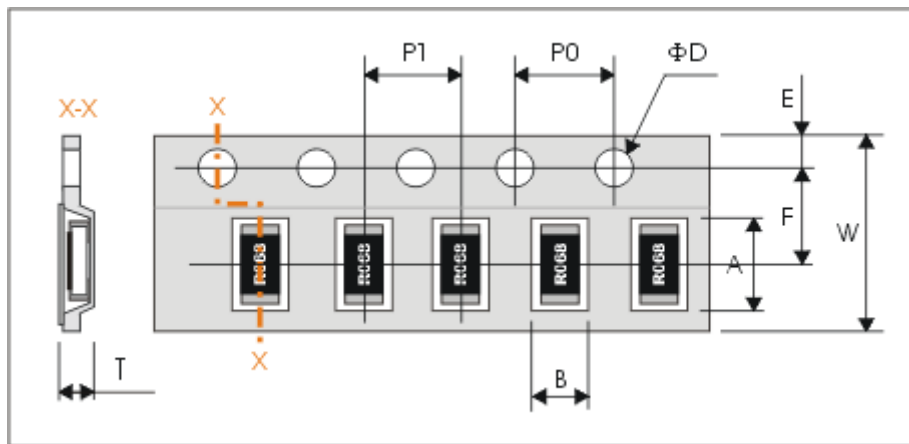

Type	A	B	W	F	E
MR18	4.90±0.20	3.55±0.30	12.00±0.30	5.50±0.10	1.75±0.10
MR20	5.50±0.20	2.80±0.20			
MR25	6.90±0.20	3.60±0.20			

Type	P1	P0	ΦD	T
MR18	8.00±0.10	4.00±0.10	Φ1.50 <sup>+0.1</sup> <sub>-0.0</sub>	1.30±0.20
MR20	4.00±0.10			MAX1.2
MR25				

**Reel dimensions**

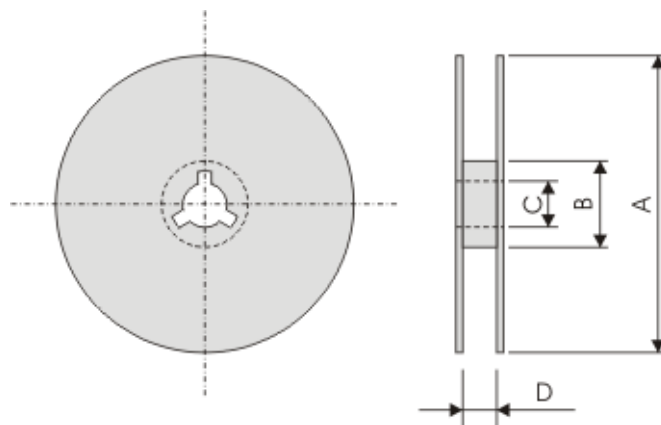

Symbol	A	B	C	D
(unit : mm)	Φ178.0±2.0	Φ60.0±1.0	13.0±0.2	14.0±0.2

**Taping quantity**

MR20, MR25 by plastic tape taping 4,000 pcs per reel.

MR18 by plastic tape taping 3,000 pcs per reel