

Features
<ul style="list-style-type: none"> <li>Frequencies from 70MHz to 140MHz</li> <li>Low amplitude ripple</li> <li>RoHS compliance</li> <li>Electrostatic sensitive device</li> <li>Compatible with EPCOS, TDK, etc</li> </ul>

Applications
<ul style="list-style-type: none"> <li>Industry</li> <li>Wireless Communication</li> <li>RF Filters for Cellular Phone</li> </ul>

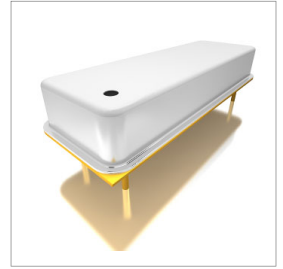

**Part Numbering Guide**

**S FL SI 34I12G 2A 26A - 70M**



\* Where letters denote decimal location (A=.0, B=.1, C=.2, etc.); e.g. B5=0.15, 3A5=3.05, 9A=9.0

Electrical Parameters (at 25 °C)	Units	Minimum	Typical	Maximum	Remarks
Center Frequency	MHz	70		140	See part number reference (page 2).
Passband width	MHz	0.4		50	See part number reference (page 2).
Insertion Loss	dB	20		35	See part number reference (page 2).
DC voltage(VDC)	V		3.0		
Operating Temperature	°C	-40		85	
Storage Temperature	°C	-55		125	
Maximum Input Power	dBm		10		
Terminating Source Impedance	Ω		50		
Terminating Load Impedance	Ω		50		

**Outline Drawing**

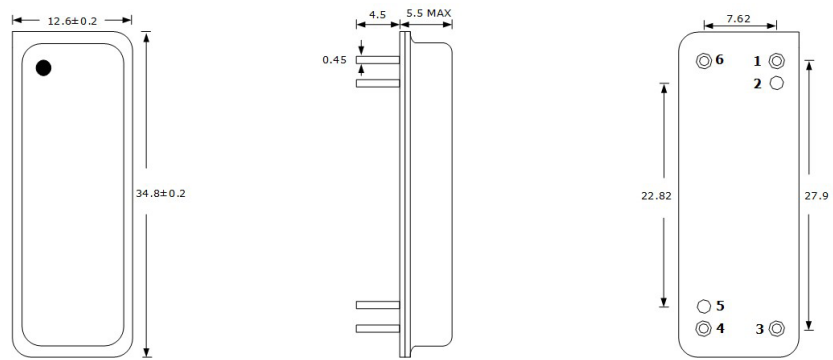

PIN #	Function
6	INPUT
4	OUTPUT
1,2,3,5	GROUND

All dimensions are in millimeters (mm) unless otherwise noted. Drawings are not to scale.

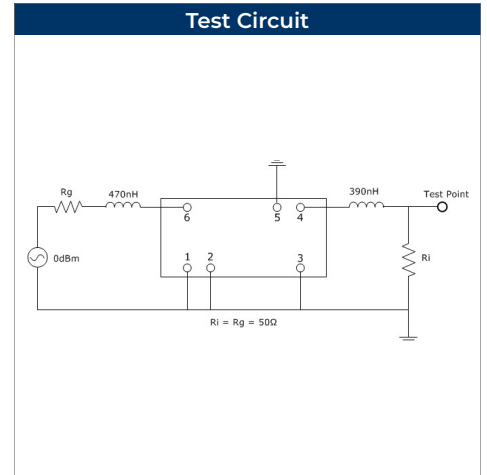
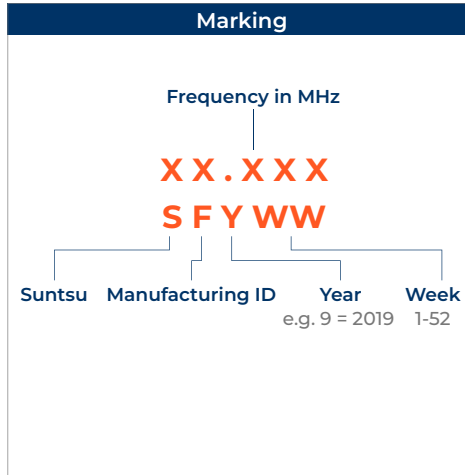
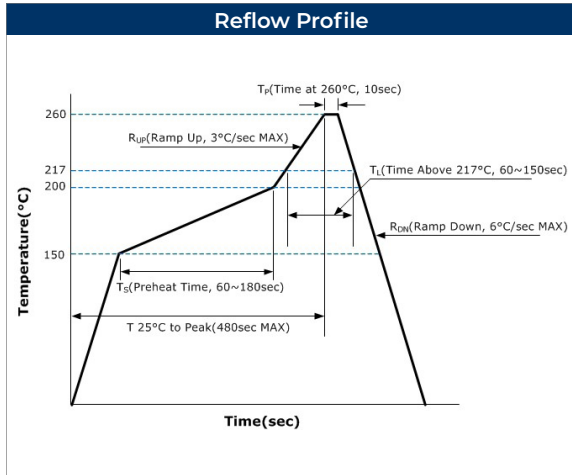

Environmental & Mechanical Specifications	
High Temperature Storage	85°C (GRADE3), 1000h, unpowered
Temperature Cycling	-40°C / 85°C (GRADE3), 1000 cycles. Dwell time :15min. Transition time: < 20 s
Humidity Test	85°C/85% relative humidity, 1000h voltage acc. Data sheet [here: 0 V]
Operational Life	Nominal RF power and maximum temperature acc. to data sheet. 85°C, 1000h
External Visual	Inspection acc. to MIL-STD-883 meth. 2009
Physical Dimension	Verification acc. to IEC 862-1
Mechanical Shock	30000 m/s <sup>2</sup> , 0.2ms, 1/2 Sin, 3x/direction
Vibration Test	10 to 2000 Hz, 0,75 mm ampl., 100 m/s <sup>2</sup>
Electrostatic Discharge	HBM : 1.5kOhm, 100pF, 1pulse +/- [here : all withstand 225VHBM]
Solderability	Solderability Solder reflow method (Pb-free), 230°C -0/+5°C, 10s (after preconditioning 155°C, 16h)
Resistance to Soldering Heat	255°C -0/+5°C, 20s

Part Number Reference Begins on Next Page

Part Number Reference	Center Frequency (MHz)	Bandwidth (MHz)	Insert Loss (dB)	Package Code
SFLSI-34I12G-1A20A-70M	70	1.0	20	34I12G
SFLSI-34I12G-4A26A-70M	70	4.0	26	34I12G
SFLSI-34I12G-6A28A-70M	70	6.0	28	34I12G
SFLSI-34I12G-8A25A-70M	70	8.0	25	34I12G
SFLSI-34I12G-14E25A-70M	70	14.4	25	34I12G
SFLSI-34I12G-12A25A-70M	70	12.0	25	34I12G
SFLSI-34I12G-40A33A-70M	70	40.0	33	34I12G
SFLSI-34I12G-40A31A-70M	70	40.0	31	34I12G
SFLSI-34I12G-40A33A-70M	70	40.0	33	34I12G
SFLSI-34I12G-40E30A-70M	70	40.4	30	34I12G
SFLSI-34I12G-48A33A-70M	70	48.0	33	34I12G
SFLSI-34I12G-48A34A-70M	70	48.0	34	34I12G
SFLSI-34I12G-50A35A-70M	70	50.0	35	34I12G
SFLSI-34I12G-25A29A-90M	90	25.0	29	34I12G
SFLSI-34I12G-48A35A-90M	90	48.0	35	34I12G
SFLSI-34I12G-48C35A-90M	90	48.2	35	34I12G
SFLSI-34I12G-E15A-140M	140	0.4	15	34I12G
SFLSI-34I12G-14G29A-140M	140	14.6	29	34I12G
SFLSI-34I12G-20A24A-140M	140	20.0	24	34I12G
SFLSI-34I12G-36A35A-140M	140	36.0	35	34I12G
SFLSI-34I12G-35A31A-140M	140	35.0	31	34I12G
SFLSI-34I12G-48A32A-140M	140	48.0	32	34I12G
SFLSI-34I12G-50A31A-140M	140	50.0	31	34I12G