



SGM3736

PWM Dimming, 38V Step-Up LED Driver

GENERAL DESCRIPTION

The SGM3736 is a versatile constant current LED driver with a high efficiency step-up converter architecture. The low-side power MOSFET is integrated in the device, significantly shrinking the overall PCB layout area and minimizing the total number of external components. Unique technology and high 1.35A current limit allow SGM3736 to drive up to 38V output (10 LEDs in series). Alternatively, SGM3736 can deliver 260mA total current with 3 series LEDs per string. It can also maximize the current capability while achieving high conversion efficiency. The optimized 1.1MHz switching frequency results in reduced conduction loss and small external component size. Digital PWM dimming interface is integrated to adjust LED current. The PWM frequency is in the range from 2kHz to 60kHz.

Various protection features are built into the SGM3736, including cycle-by-cycle input current limit protection, open LED (output over-voltage) protection and thermal shutdown protection. The leakage current in shutdown mode is less than 1 μ A.

The SGM3736 is available in Green TDFN-2 \times 2-8L package. It operates over an ambient temperature range of -40 $^{\circ}$ C to +85 $^{\circ}$ C.

FEATURES

- **Wide Output Range: Up to 10 Series LEDs**
- **Integrated 40V High Current Switch (1.35A Limit)**
- **2.7V to 5.5V Input Voltage Range**
- **High Efficiency PWM Converter**
- **Low 200mV Feedback Voltage**
- **500k Ω Pull-Down Resistor on EN/PWM Pin**
- **2kHz to 60kHz PWM Dimming Frequency**
- **38V Open LED Protection**
- **1.1MHz Switching Frequency**
- **Integrated Soft-Start Function**
- **Less than 1 μ A Shutdown Current**
- **Simple, Small Solution Size**
- **Available in Green TDFN-2 \times 2-8L Package**
- **-40 $^{\circ}$ C to +85 $^{\circ}$ C Operating Temperature Range**

APPLICATIONS

LED Backlighting
Mobile Phones
Handheld Devices
Digital Photo Frames
Automotive Navigation

PACKAGE/ORDERING INFORMATION

MODEL	PACKAGE DESCRIPTION	SPECIFIED TEMPERATURE RANGE	ORDERING NUMBER	PACKAGE MARKING	PACKING OPTION
SGM3736	TDFN-2×2-8L	-40°C to +85°C	SGM3736YTDE8G/TR-V1	3736 XXXX	Tape and Reel, 3000

NOTE: XXXX = Date Code.

Green (RoHS & HSF): SG Micro Corp defines "Green" to mean Pb-Free (RoHS compatible) and free of halogen substances. If you have additional comments or questions, please contact your SGMICRO representative directly.

ABSOLUTE MAXIMUM RATINGS

Input Voltage, V_{IN}	-0.3V to 6V
High Voltage Nodes, SW, VOUT	-0.3V to 40V
Other Pins, FB, EN/PWM.....	-0.3V to $V_{IN} + 0.3V$
Package Thermal Resistance	
TDFN-2×2-8L, θ_{JA}	75°C/W
Junction Temperature	150°C
Storage Temperature Range	-65°C to +150°C
Lead Temperature (Soldering, 10sec)	260°C
ESD Susceptibility	
HBM.....	3000V
MM.....	200V

RECOMMENDED OPERATING CONDITIONS

Input Voltage Range	2.7V to 5.5V
Operating Temperature Range	-40°C to +85°C

OVERSTRESS CAUTION

Stresses beyond those listed may cause permanent damage to the device. Functional operation of the device at these or any other conditions beyond those indicated in the operational section of the specification is not implied. Exposure to absolute maximum rating conditions for extended periods may affect reliability.

ESD SENSITIVITY CAUTION

This integrated circuit can be damaged by ESD if you don't pay attention to ESD protection. SGMICRO recommends that all integrated circuits be handled with appropriate precautions. Failure to observe proper handling and installation procedures can cause damage. ESD damage can range from subtle performance degradation to complete device failure. Precision integrated circuits may be more susceptible to damage because very small parametric changes could cause the device not to meet its published specifications.

DISCLAIMER

SG Micro Corp reserves the right to make any change in circuit design, specification or other related things if necessary without notice at any time.

PIN CONFIGURATION

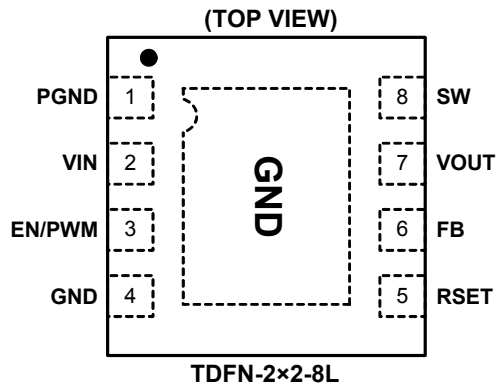

PIN DESCRIPTION

PIN	NAME	FUNCTION
1	PGND	Power Ground.
2	VIN	Supply Input.
3	EN/PWM	Enable Control and PWM Dimming Input. It is a multi-functional pin which can be used for enable control and digital PWM dimming.
4	GND	Ground.
5	RSET	RSET Pin. Connect one resistor from RSET pin to GND to program the maximum white LED current.
6	FB	Feedback Input. Connect this pin to the cathode of the white LED.
7	VOUT	Output and Over-Voltage Protection Pin.
8	SW	Switch Output. Connect this pin to the inductor and the Schottky diode.
Exposed Pad	GND	Exposed pad should be soldered to PCB board and connected to GND.

TYPICAL APPLICATION

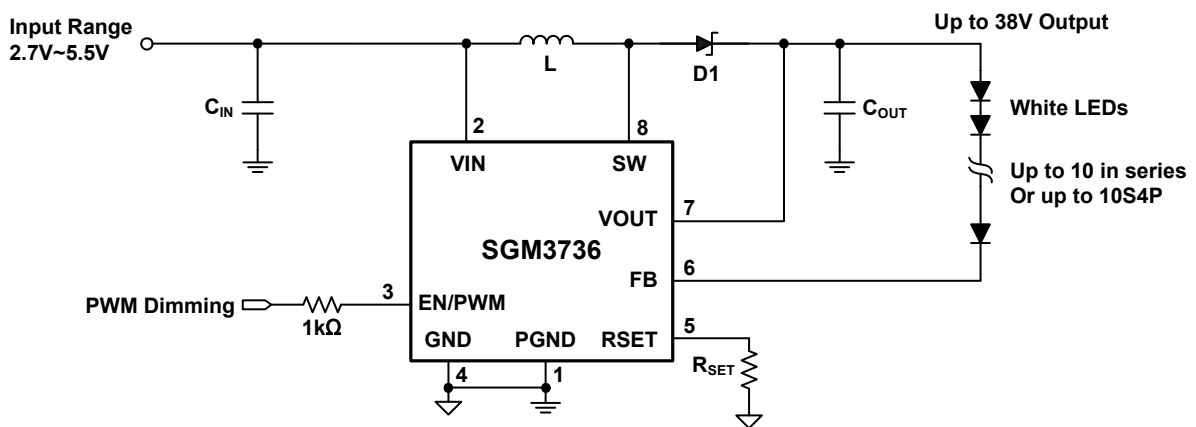

Figure 1. Typical Application Circuit

ELECTRICAL CHARACTERISTICS ⁽¹⁾

($V_{IN} = 3.6V$, $L = 10\mu H$, $C_{IN} = 10\mu F$, $C_{OUT} = 0.47\mu F$, Full = $-40^{\circ}C$ to $+85^{\circ}C$, typical values are at $T_A = +25^{\circ}C$, unless otherwise noted.)

PARAMETER	SYMBOL	CONDITIONS	TEMP	MIN	TYP	MAX	UNITS
IC SUPPLY							
Input Voltage Range	V_{IN}		Full	2.7		5.5	V
Input Under-Voltage Lockout	UVLO	Rising edge	$+25^{\circ}C$		2.5	2.6	V
UVLO Hysteresis	V_{HYS}		$+25^{\circ}C$		0.15		V
Quiescent Current (Non Switching)	I_Q	$V_{FB} = 0.4V$	$+25^{\circ}C$		0.20	0.35	mA
Operating Current (Switching)		$V_{FB} = 0V$	$+25^{\circ}C$		0.72	1.5	mA
VIN Pin Shutdown Current	I_{SHDN}	$V_{EN} = 0V$	$+25^{\circ}C$		0.1	1	μA
STEP-UP CONVERTER							
Voltage Feedback Regulation Voltage	V_{REF}		Full	192	200	212.5	mV
Voltage Feedback Regulation Voltage Under Brightness Control	V_{REF_PWM}	$f_{PWM} = 10kHz$, duty cycle = 3%	$+25^{\circ}C$	3.5	6	8.5	mV
V_{REF} Filter 3dB Frequency	$f_{REF(3dB)}$		$+25^{\circ}C$		600		Hz
SW Pin Leakage Current	I_{SW}		$+25^{\circ}C$		0.01	1	μA
Peak NMOS Current Limit	I_{LIM}		$+25^{\circ}C$		1.35		A
Oscillator Frequency	f_S		Full	0.90	1.10	1.4	MHz
Over-Voltage Threshold	V_{OVP}	Measured at VOUT pin	Full	35.5	38.0	40.5	V
Start-Up Time	t_S		$+25^{\circ}C$		800		μs
CONTROL							
Logic Low Threshold	V_{IL}		Full			0.35	V
Logic High Threshold	V_{IH}		Full	1.5			V
PWM Dimming Frequency Range	DFR		$+25^{\circ}C$	2		60	kHz
Minimum Shutdown Pulse Width Timing	t_{OFF}		$+25^{\circ}C$	3			ms
Junction Thermal Shutdown Threshold					150		$^{\circ}C$
Junction Thermal Shutdown Hysteresis					15		$^{\circ}C$

NOTE:

1. The SGM3736 is guaranteed to meet performance specifications over the $-40^{\circ}C$ to $+85^{\circ}C$ operating temperature range by design, characterization and correlation with statistical process controls.

RECOMMENDED COMPONENTS OF TEST CIRCUITS

	COMPONENT		COMPONENT
INDUCTOR	22 μ H/CD75NP-220KC	CAPACITOR	10 μ F/C2012X7R1H106KT
	10 μ H/CD75NP-100KC		0.47 μ F/C2012X7R1H474KT
DIODE	MBR0540		

TYPICAL PERFORMANCE CHARACTERISTICS

T_A = +25°C, L = 10 μ H, C_{IN} = 10 μ F, C_{OUT} = 0.47 μ F, unless otherwise noted.

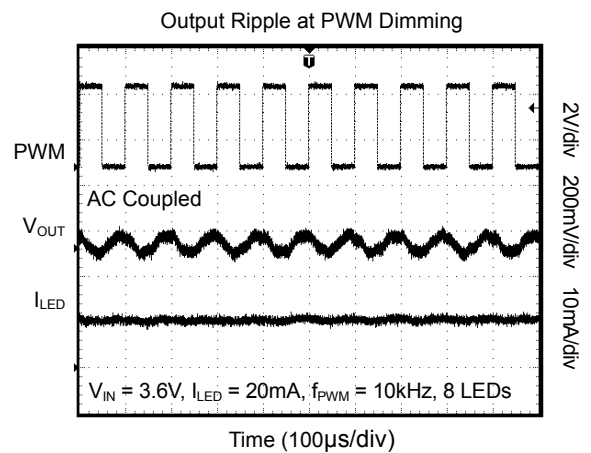
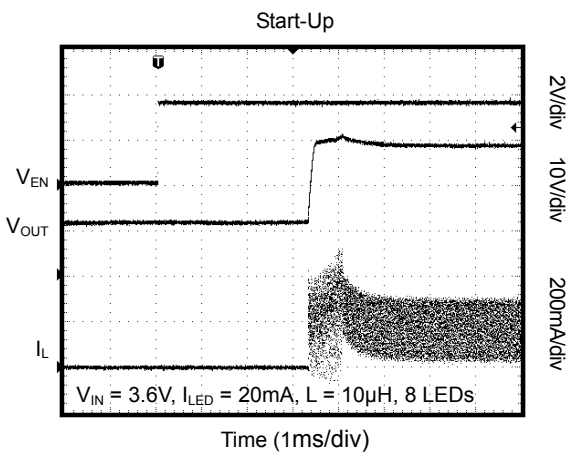
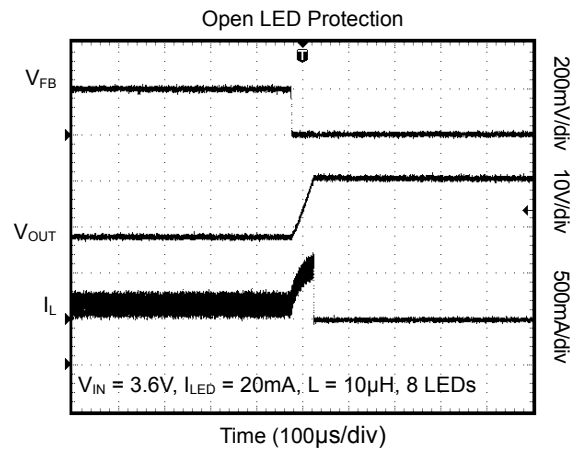
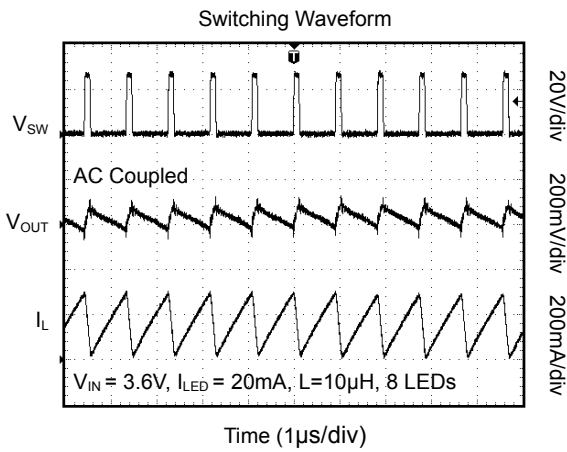

TYPICAL PERFORMANCE CHARACTERISTICS

T_A = +25°C, L = 10µH, C_{IN} = 10µF, C_{OUT} = 0.47µF, unless otherwise noted.

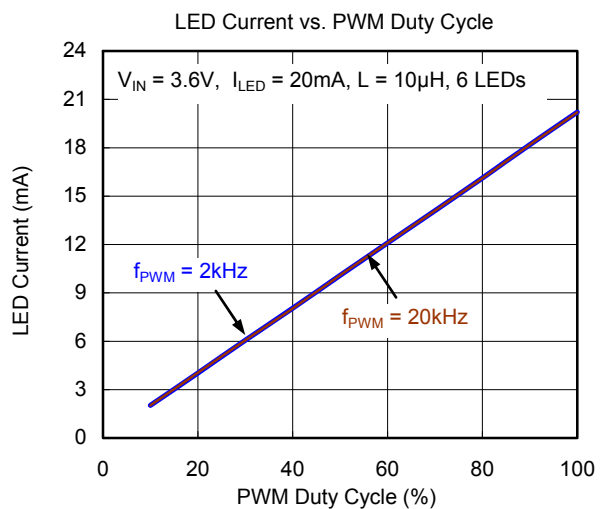
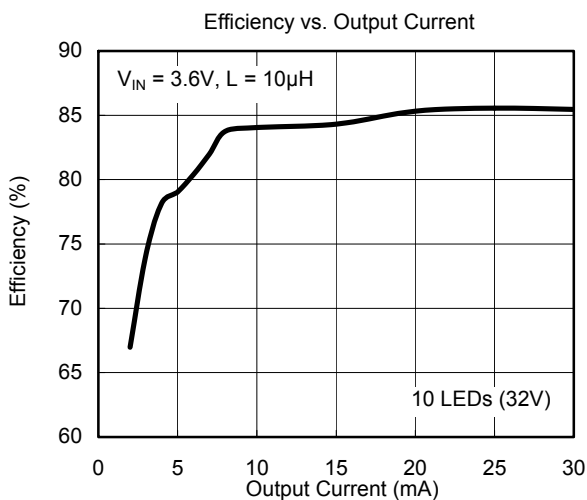
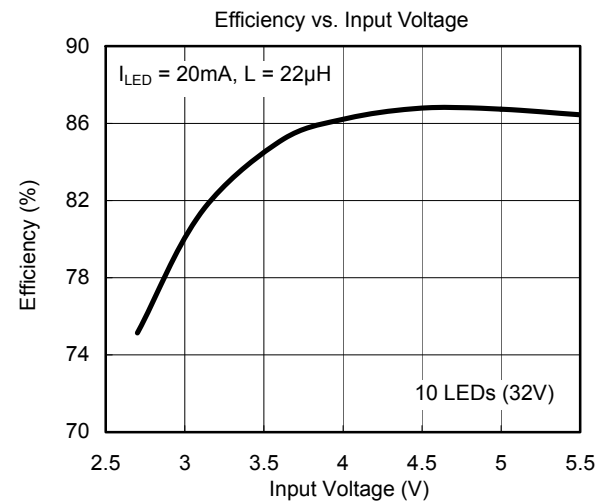
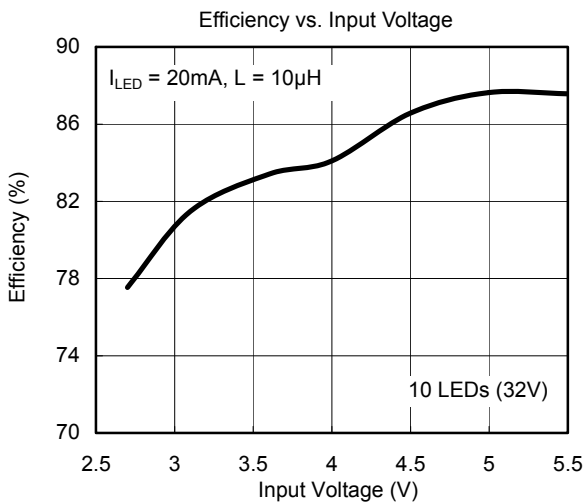
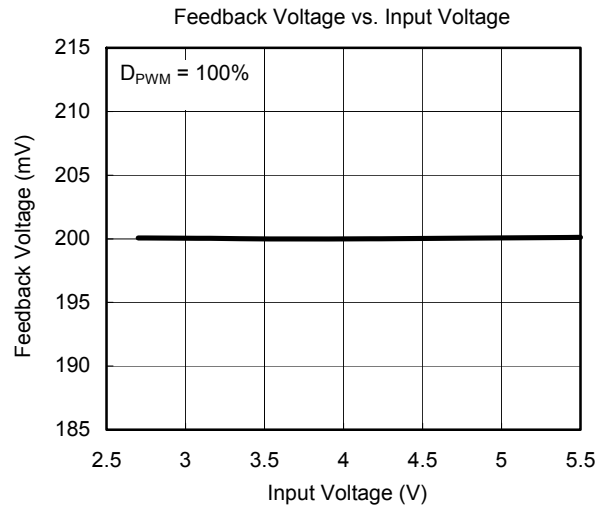
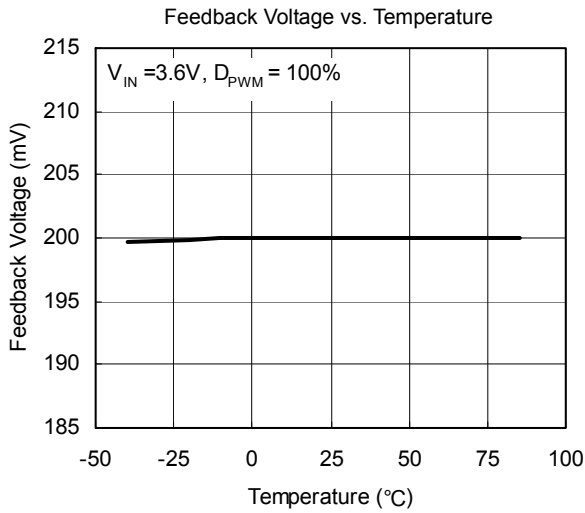

FUNCTIONAL BLOCK DIAGRAM

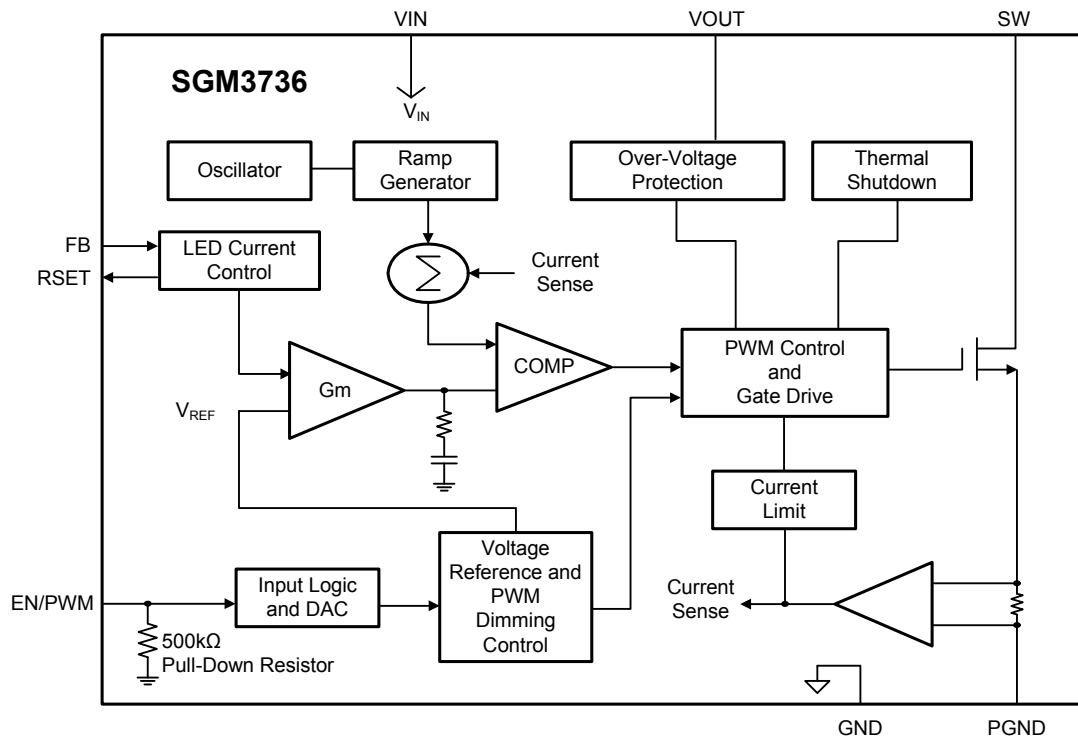

Figure 2. SGM3736 Block Diagram

FUNCTIONAL DESCRIPTION

The SGM3736 uses a constant-frequency current-mode boost converter architecture to control the LED current by regulating the feedback voltage. Please refer to the FUNCTIONAL BLOCK DIAGRAM above for an explanation of SGM3736 operation. The beginning of each cycle turns on the Power MOSFET. A slope compensation ramp is added to the output of the current sense amplifier and the result is fed into the positive input of the comparator (COMP). When this voltage goes above the output voltage of the error amplifier (Gm), the Power MOSFET is turned off. The voltage at the output of the Gm block amplifies the difference between the reference voltage and the feedback voltage (FB), so that FB voltage can be regulated to the reference voltage.

The SGM3736 has built-in soft-start to limit the inrush current during startup and to limit the amount of overshoot on the output. Protection features in the SGM3736 include over-voltage protection (OVP), cycle-by-cycle current limit protection and thermal shutdown. OVP protects in the event where an LED fails open, which forces the feedback voltage to zero. This causes the boost converter to operate in maximum duty cycle mode, ramping up the output voltage.

Switching will stop when the output reaches the OVP threshold. The OVP feature protects the IC from damaging itself by exceeding the voltage rating on SW/VOUT pins.

For the brightness dimming control of the SGM3736, the IC provides typically 200mV feedback voltage when the EN/PWM pin is pulled constantly high. However, EN/PWM pin allows a PWM signal to reduce this regulation voltage by changing the PWM duty cycle to achieve LED brightness dimming control. An internal low pass filter (600Hz) is used to filter the pulse signal. The relationship between the duty cycle and FB voltage can be calculated as following equation.

$$V_{FB} = \text{Duty} \times 200\text{mV}$$

Where:

Duty = duty cycle of the PWM signal
200mV = internal reference voltage

The PWM frequency is in the range from 2kHz to 60kHz, and the recommended minimum PWM duty cycle is 3% for no blind dimming.

APPLICATION INFORMATION

Inductor Selection

A 6.8µH to 22µH inductor is recommended for 10/8/6 series LED applications and 10S4P LED applications. If high efficiency is a critical requirement, a low DCR inductor should be selected. The inductor's saturation current rating should also exceed the peak input current, especially for high load current application (like 10S4P).

Capacitor Selection

Small size ceramic capacitors are ideal for SGM3736 application. An input capacitor in the range of 1µF to 22µF and a 0.47µF output capacitor are suggested for 10/8/6 series LED applications. For higher output current applications like 10S4P, larger value output capacitors like 2.2µF are recommended to minimize output ripple.

Diode Selection

The current rating of the Schottky diode should exceed the peak current of the boost converter. The voltage rating should also exceed the target output voltage.

LED Maximum Current Setting

LED maximum current setting, I_{MAX} , is determined by the feedback resistor (R_{SET} in Figure 3). The feedback voltage is internally set at 200mV when the PWM

dimming duty cycle = 100%. The LED current is programmed according to the formula $I_{MAX} = 200mV/R_{SET}$. For accurate LED current settings, precision 1% resistors are recommended. The formula and table for R_{SET} selection are shown below.

$$R_{SET} = 200mV/I_{MAX}$$

Table 1. Current Setting Resistor

R_{SET} (Ω)	I_{MAX} Current (mA)
200	1
40.2	5
20.0	10
13.3	15
10.0	20
6.65	30
2.00	100

Layout Considerations

PCB layout is very important for high frequency switching regulators in order to keep the loop stable and minimize noise. The input capacitor should be very close to the IC to get the best decoupling. The path of the inductor and output capacitor should be kept as short as possible to minimize noise and ringing.

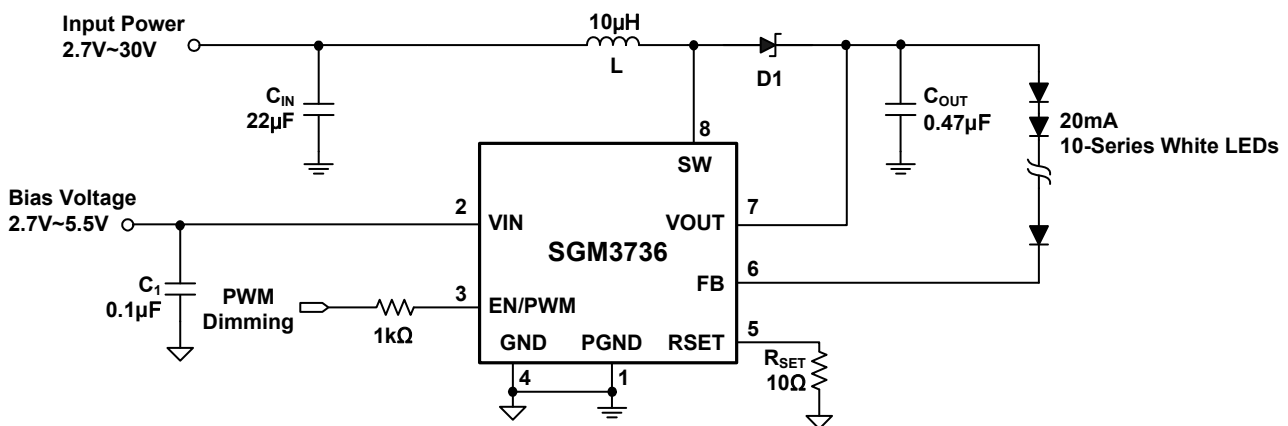
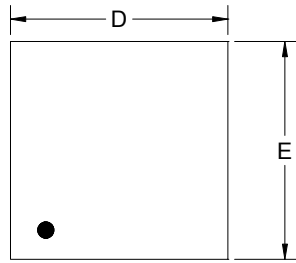

Figure 3. Application Circuit for 10 LEDs in Series with 20mA Current (V_{IN} can be tied to input power rail if less than 5.5V)

PACKAGE OUTLINE DIMENSIONS

TDFN-2x2-8L



TOP VIEW

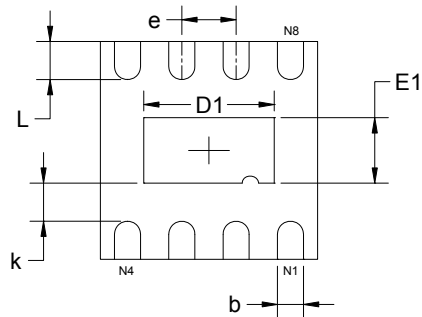

BOTTOM VIEW

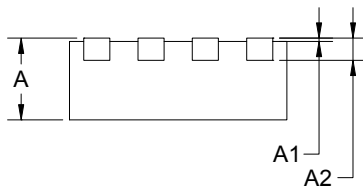

SIDE VIEW

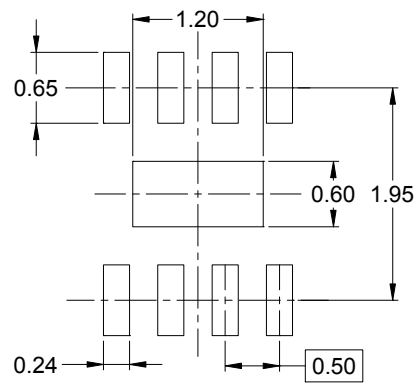

RECOMMENDED LAND PATTERN (Unit: mm)

Symbol	Dimensions In Millimeters		Dimensions In Inches	
	MIN	MAX	MIN	MAX
A	0.700	0.800	0.028	0.031
A1	0.000	0.050	0.000	0.002
A2	0.203 REF		0.008 REF	
D	1.900	2.100	0.075	0.083
D1	1.100	1.300	0.043	0.051
E	1.900	2.100	0.075	0.083
E1	0.500	0.700	0.020	0.028
k	0.200 MIN		0.008 MIN	
b	0.180	0.300	0.007	0.012
e	0.500 TYP		0.020 TYP	
L	0.250	0.450	0.010	0.018

TAPE AND REEL INFORMATION

REEL DIMENSIONS

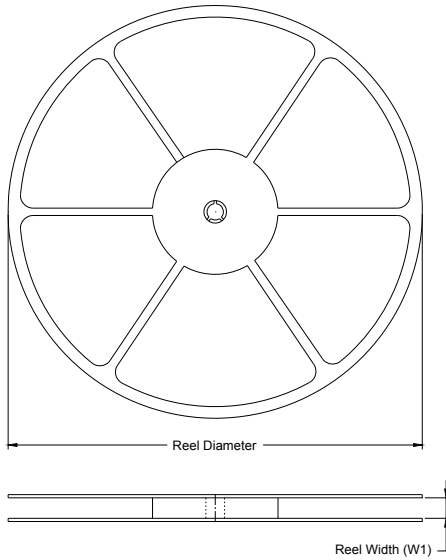

TAPE DIMENSIONS

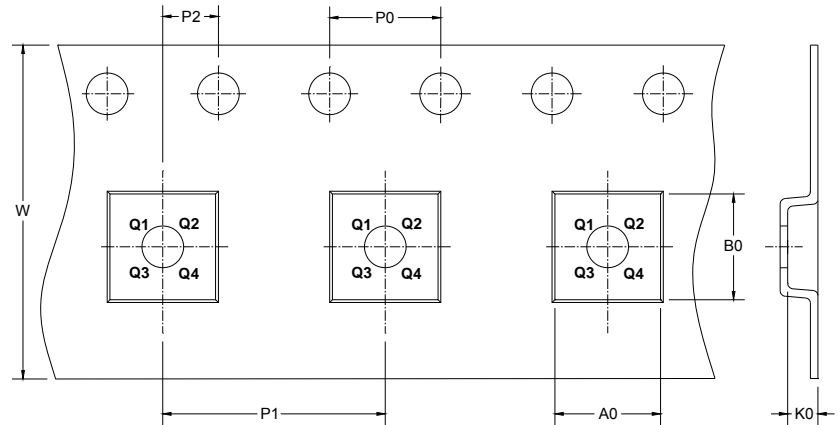

➔ DIRECTION OF FEED

NOTE: The picture is only for reference. Please make the object as the standard.

KEY PARAMETER LIST OF TAPE AND REEL

Package Type	Reel Diameter	Reel Width W1 (mm)	A0 (mm)	B0 (mm)	K0 (mm)	P0 (mm)	P1 (mm)	P2 (mm)	W (mm)	Pin1 Quadrant
TDFN-2x2-8L	7"	9.5	2.30	2.30	1.10	4.00	4.00	2.00	8.00	Q1

000001

PACKAGE INFORMATION

CARTON BOX DIMENSIONS

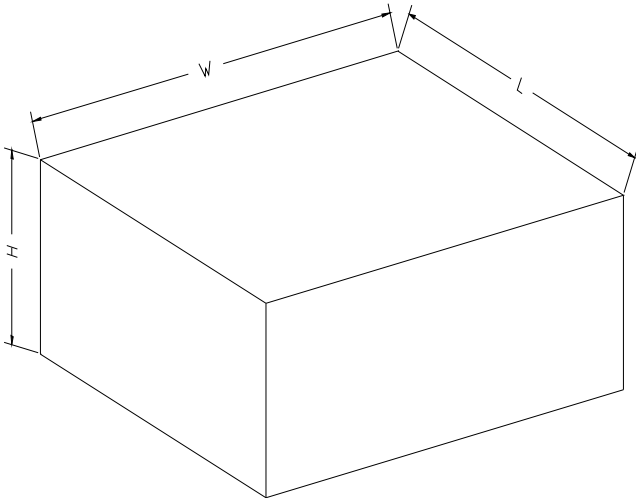

NOTE: The picture is only for reference. Please make the object as the standard.

KEY PARAMETER LIST OF CARTON BOX

Reel Type	Length (mm)	Width (mm)	Height (mm)	Pizza/Carton
7" (Option)	368	227	224	8
7"	442	410	224	18

DD0002