

Switch Mode Power Supply S8JX (15/35/50/100/150/300/600-W Models)

Wide Variety of Output Voltage Variations: 48 V for 15 to 150 W, and 5 or 12 V for 150 W

- Easy Mounting:
Mounting Bracket provided as a standard feature.
(except for DIN Rail-mounting models)
Mounts to DIN Rail. (except 600-W model)
Screw-mount at the top. (except 300-/600-W models)
- Safety standards:
UL 508/60950-1
cUL CSA C22.2 No. 107.1
cUR CSA C22.2 No. 60950-1
EN 50178 (= VDE 0160)
EN 60950-1 (= VDE 0805 Teil 1)
- EMC: Conforms to EN 61204-3 Class A.
(EMI: EN55011)
(EMS: EN61000-4)
- Input conditions:
The input voltage range of 15-W, 35-W,
50-W, 100-W, and 150-W models has been
increased to 80 to 370 VDC (EC Directives
and safety standards do not apply.).

Note: Refer to *Safety Precautions* on page 24.



Model Number Structure

Model Number Legend

- Note:** 1. Not all combinations are possible. Refer to *List of Models* in *Ordering Information* on page 2.
2. Estimates can be provided for coatings and other specifications that are not given in the datasheet. Ask your OMRON representative for details.

15-/35-/50-/100-/150-W Models

S8JX-G□□□□□□□□
 1 2 3 4

1. Power Ratings

015: 15 W
035: 35 W
050: 50 W
100: 100 W
150: 150 W

2. Output Voltage

05: 5 V
12: 12 V
15: 15 V
24: 24 V
48: 48 V

3. Configuration (15/35/50/100/150 W model)

None: Open-frame
C: Covered

4. Configuration/mounting

None: Front-mounting
D: DIN Rail-mounting

300-/600-W Models

S8JX-G□□□□□□□□
 1 2 3

1. Power Ratings

300: 300 W
600: 600 W

2. Output Voltage

24: 24 V

3. Configuration/mounting (covered type)

C: Front-mounting
CD: DIN Rail-mounting

Note: Estimates can be provided for coatings and other specifications that are not given in the datasheet. Ask your OMRON representative for details.

S8JX

Ordering Information

List of Models

Note: For details on normal stock models, contact your nearest OMRON representative.

| Configuration | Input voltage | Power ratings | Output voltage (VDC) | Output current | Model | | |
|---------------------------|-------------------|----------------------|--|----------------|-------------|--------------|--------------|
| Open-frame Power Supplies | Front-mounting *1 | 15 W | 5 V | 3 A | S8JX-G01505 | | |
| | | | 12 V | 1.3 A | S8JX-G01512 | | |
| | | | 15 V | 1 A | S8JX-G01515 | | |
| | | | 24 V | 0.65 A | S8JX-G01524 | | |
| | | 48 V | 0.35 A | S8JX-G01548 | | | |
| | | 35 W | 5 V | 7 A | S8JX-G03505 | | |
| | | | 12 V | 3 A | S8JX-G03512 | | |
| | | | 15 V | 2.4 A | S8JX-G03515 | | |
| | | | 24 V | 1.5 A | S8JX-G03524 | | |
| | | 50 W | 48 V | 0.75 A | S8JX-G03548 | | |
| | | | 5 V | 10 A | S8JX-G05005 | | |
| | | | 12 V | 4.2 A | S8JX-G05012 | | |
| | | | 24 V | 2.1 A | S8JX-G05024 | | |
| | | 100 W | 48 V | 1.1 A | S8JX-G05048 | | |
| | | | 5 V | 20 A | S8JX-G10005 | | |
| | | | 12 V | 8.5 A | S8JX-G10012 | | |
| | | | 24 V | 4.5 A | S8JX-G10024 | | |
| | | 150 W | 48 V | 2.1 A | S8JX-G10048 | | |
| | | | 5 V | 30 A | S8JX-G15005 | | |
| | | | 12 V | 13 A | S8JX-G15012 | | |
| | | | 24 V | 6.5 A | S8JX-G15024 | | |
| | | DIN Rail-mounting *2 | 100 to 240 VAC (free) (80 to 370 VDC *3) S8JX-G15005□: Switchable between 100 to 120 VAC and 200 to 240 VAC. (DC power cannot be input.) | 15 W | 48 V | 3.3 A | S8JX-G15048 |
| | | | | | 5 V | 3 A | S8JX-G01505D |
| | | | | | 12 V | 1.3 A | S8JX-G01512D |
| | 15 V | | | | 1 A | S8JX-G01515D | |
| | 35 W | | | 24 V | 0.65 A | S8JX-G01524D | |
| | | | | 48 V | 0.35 A | S8JX-G01548D | |
| | | | | 5 V | 7 A | S8JX-G03505D | |
| | | | | 12 V | 3 A | S8JX-G03512D | |
| | 50 W | | | 15 V | 2.4 A | S8JX-G03515D | |
| | | | | 24 V | 1.5 A | S8JX-G03524D | |
| | | | | 48 V | 0.75 A | S8JX-G03548D | |
| | | | | 5 V | 10 A | S8JX-G05005D | |
| | 100 W | | | 12 V | 4.2 A | S8JX-G05012D | |
| | | | | 24 V | 2.1 A | S8JX-G05024D | |
| | | | | 48 V | 1.1 A | S8JX-G05048D | |
| | | | | 5 V | 20 A | S8JX-G10005D | |
| | 150 W | | | 12 V | 8.5 A | S8JX-G10012D | |
| | | | | 24 V | 4.5 A | S8JX-G10024D | |
| | | | | 48 V | 2.1 A | S8JX-G10048D | |
| | | | | 5 V | 30 A | S8JX-G15005D | |
| | | | | 12 V | 13 A | S8JX-G15012D | |
| | | | | 24 V | 6.5 A | S8JX-G15024D | |
| | | | | 48 V | 3.3 A | S8JX-G15048D | |
| | | | | | | | |

*1. The front-mounting bracket is included as standard with the product.

*2. A front-mounting bracket is not included with the product.

*3. The range for compliance with EC Directives and safety standards (UL, EN, etc.) is 100 to 240 VAC (85 to 264 VAC).

S8JX

| Configuration | | Input voltage | Power ratings | Output voltage (VDC) | Output current | Model |
|------------------------|----------------------|---|---------------|----------------------|----------------|---------------|
| Covered Power Supplies | Front-mounting *1 | 100 to 240 VAC (free) (80 to 370 VDC *3) S8JX-G15005□□□: Switchable between 100 to 120 VAC and 200 to 240 VAC. (DC power cannot be input.) | 15 W | 5 V | 3 A | S8JX-G01505C |
| | | | | 12 V | 1.3 A | S8JX-G01512C |
| | | | | 15 V | 1 A | S8JX-G01515C |
| | | | | 24 V | 0.65 A | S8JX-G01524C |
| | | | | 48 V | 0.35 A | S8JX-G01548C |
| | | | 35 W | 5 V | 7 A | S8JX-G03505C |
| | | | | 12 V | 3 A | S8JX-G03512C |
| | | | | 15 V | 2.4 A | S8JX-G03515C |
| | | | | 24 V | 1.5 A | S8JX-G03524C |
| | | | | 48 V | 0.75 A | S8JX-G03548C |
| | | | 50 W | 5 V | 10 A | S8JX-G05005C |
| | | | | 12 V | 4.2 A | S8JX-G05012C |
| | | | | 24 V | 2.1 A | S8JX-G05024C |
| | | | | 48 V | 1.1 A | S8JX-G05048C |
| | | | 100 W | 5 V | 20 A | S8JX-G10005C |
| | | | | 12 V | 8.5 A | S8JX-G10012C |
| | | | | 24 V | 4.5 A | S8JX-G10024C |
| | | | | 48 V | 2.1 A | S8JX-G10048C |
| | | | 150 W | 5 V | 30 A | S8JX-G15005C |
| | | | | 12 V | 13 A | S8JX-G15012C |
| | 24 V | 6.5 A | | S8JX-G15024C | | |
| | 48 V | 3.3 A | | S8JX-G15048C | | |
| | DIN Rail-mounting *2 | 100 to 120 VAC 200 to 240 VAC (Switchable) | 15 W | 5 V | 3 A | S8JX-G01505CD |
| | | | | 12 V | 1.3 A | S8JX-G01512CD |
| | | | | 15 V | 1 A | S8JX-G01515CD |
| | | | | 24 V | 0.65 A | S8JX-G01524CD |
| | | | | 48 V | 0.35 A | S8JX-G01548CD |
| | | | 35 W | 5 V | 7 A | S8JX-G03505CD |
| | | | | 12 V | 3 A | S8JX-G03512CD |
| | | | | 15 V | 2.4 A | S8JX-G03515CD |
| | | | | 24 V | 1.5 A | S8JX-G03524CD |
| | | | | 48 V | 0.75 A | S8JX-G03548CD |
| | | | 50 W | 5 V | 10 A | S8JX-G05005CD |
| | | | | 12 V | 4.2 A | S8JX-G05012CD |
| | | | | 24 V | 2.1 A | S8JX-G05024CD |
| | | | | 48 V | 1.1 A | S8JX-G05048CD |
| | | | 100 W | 5 V | 20 A | S8JX-G10005CD |
| | | | | 12 V | 8.5 A | S8JX-G10012CD |
| | | | | 24 V | 4.5 A | S8JX-G10024CD |
| | | | | 48 V | 2.1 A | S8JX-G10048CD |
| | | | 150 W | 5 V | 30 A | S8JX-G15005CD |
| | | | | 12 V | 13 A | S8JX-G15012CD |
| | 24 V | 6.5 A | | S8JX-G15024CD | | |
| | 48 V | 3.3 A | | S8JX-G15048CD | | |
| | Front-mounting *1 | 100 to 120 VAC 200 to 240 VAC (Switchable) | 300 W | 24 V | 14 A | S8JX-G30024C |
| | DIN Rail-mounting *2 | | 600 W | | 27 A | S8JX-G60024C |
| | 300 W | | 14 A | | S8JX-G30024CD | |

*1. The front-mounting bracket is included as standard with the product.

*2. A front-mounting bracket is not included with the product.

*3. The range for compliance with EC Directives and safety standards (UL, EN, etc.) is 100 to 240 VAC (85 to 264 VAC).

Ratings, Characteristics, and Functions

| Item | | Input specification | | 100 to 240 V input | | |
|--|--|----------------------------------|---|---|------------|--|
| | | Power ratings *1 | | 15 W | 35 W | |
| Efficiency | | | | 68% min. | 73% min. | |
| Input | Voltage *2 | | 100 to 240 VAC (allowable range: 85 to 264 VAC) | | | |
| | Frequency *2 | | 80 to 370 VDC *9 Note: This range is not applicable for the safety standards. | | | |
| | Current *3 | | 100 V input | 0.4 A max. | 1 A max. | |
| | | | 200 V input | 0.25 A max. | 0.6 A max. | |
| | Power factor | | --- | | | |
| | Harmonic current emissions | | --- | | | |
| | Leakage current *3 | | 100 V input | 0.5 mA max. | | |
| | | | 200 V input | 1 mA max. | | |
| | Inrush current (for a cold start at 25°C) *3 | | 100 V input | 20 A max. | | |
| | | | 200 V input | 40 A max. | | |
| Noise filter | | Yes | | | | |
| Output *4 | Voltage adjustment range *5 | | -10% to 15% (with V. ADJ) (48-V models: ±10%) | | | |
| | Ripple *3 | | 2% (p-p) max. | | | |
| | Input variation influence | | 0.4% max. with AC input voltage | | | |
| | Load variation influence | | 0.8% max. (0 to 100% load, rated input voltage) | | | |
| | Temperature variation influence | | 0.05%/°C max. (at rated input and output) | | | |
| | Startup time | | 500 ms max. (up to 90% of output voltage at rated input and output) | | | |
| | Hold time *3 | | 20 ms min. | | | |
| Additional functions | Overload protection *6 | | 105% to 175% of rated load current, voltage drop, intermittent, automatic reset | | | |
| | Overvoltage protection *7 | | Yes | | | |
| | Overheat protection | | No | | | |
| | Parallel operation | | No | | | |
| | Series operation | | Yes (For up to two Power Supplies; external diodes required.) | | | |
| Protective circuit operation indicator | | No | | | | |
| Other | Ambient operating temperature | | Refer to the derating curve in <i>Engineering Data</i> on page 13 (with no icing or condensation). | | | |
| | Storage temperature | | -25 to 65°C (with no icing or condensation) | | | |
| | Ambient operating humidity | | 25% to 85% (Storage humidity: 25% to 90%) | | | |
| | Dielectric strength | | 3.0 kVAC for 1 min. (between all inputs and outputs; detection current: 20 mA) 2.0 kVAC for 1 min. (between all inputs and PE terminals; detection current: 20 mA) 1.0 kVAC for 1 min. (between all outputs and PE terminals; detection current: 20 mA) | | | |
| | Insulation resistance | | 100 MΩ min. (between all outputs and all inputs/PE terminals) at 500 VDC | | | |
| | Vibration resistance | | 10 to 55 Hz, 0.375-mm single amplitude for 2 h each in X, Y, and Z directions | | | |
| | Shock resistance | | 150 m/s ² , 3 times each in ±X, ±Y, ±Z directions | | | |
| | Output indicator | | Yes (Color: Green) | | | |
| | EMI | Conducted Emissions | | Conforms to EN 55011 Group 1 Class A and based on FCC Class A | | |
| | | Radiated Emissions | | Conforms to EN 55011 Group 1 Class A | | |
| | EMS | Electrostatic Discharge | | Confirms to EN61000-4-2 | | |
| | | Radiated Electromagnetic Field | | Confirms to EN61000-4-3 | | |
| | | Electrical Fast Transient/Burst | | Confirms to EN61000-4-4 | | |
| | | Surge | | Confirms to EN61000-4-5 | | |
| | | Conducted Disturbance | | Confirms to EN61000-4-6 | | |
| | | Voltage Dips/Short Interruptions | | Confirms to EN61000-4-11 | | |
| | Approved standards *9 | | UL Listed: UL 508 (Listing), UL UR: UL 60950-1 (Recognition) cUL Listed: CSA C22.2 No.107.1 cUR: CSA C22.2 No. 60950-1 EN/VDE: EN50178 (= VDE 0160), EN 60950-1 (= VDE 0805 Teil 1) (Terminal block: Based on DIN 50274 (VDE 0660-514)) | | | |
| SEMI | | SEMI F47-0200 (200-VAC input) | | | | |
| Weight *8 | | 250 g max. | | | | |

*1. When a load is connected that has a built-in DC-DC converter, the overload protection may operate at startup and the Power Supply may not start. Refer to *Overload Protection* on page 15.

*2. Do not use an Inverter output for the Power Supply. Inverters with an output frequency of 50/60 Hz are available, but the rise in the internal temperature of the Power Supply may result in ignition or burning.

*3. Rated input voltage: 100 or 200 VAC at 100% load.

*4. Output characteristics: Specified at power supply output terminals.

*5. If the output voltage adjuster (V. ADJ) is turned, the voltage will increase by more than the allowable voltage range. When adjusting the output voltage, confirm the actual output voltage from the Power Supply and be sure that load is not damaged.

*6. For details, refer to *Overload Protection* on page 15.

*7. To reset the protection, turn OFF the input power for seven minutes or longer and then turn it back ON.

*8. The weight indicated is a for Front-mounting, Open-frame Power Supply.

*9. The range for compliance with EC Directives and safety standards (UL, EN, etc.) is 100 to 240 VAC (85 to 264 VAC).

| Item | Input specification | | 100 to 240 V input | |
|--|---|--|---|------------|
| | Power ratings *1 | | 50 W | 100 W |
| Efficiency | | | 76% min. | |
| Input | Voltage *2 | 100 to 240 VAC (allowable range: 85 to 264 VAC) | | |
| | | 80 to 370 VDC *9 Note: This range is not applicable for the safety standards. | | |
| | Frequency *2 | 50/60 Hz (47 to 450 Hz) | | |
| | Current *3 | 100 V input | 1.4 A max. | 2.5 A max. |
| | | 200 V input | 0.8 A max. | 1.5 A max. |
| | Power factor | --- | | |
| | Harmonic current emissions | --- | | |
| | Leakage current *3 | 100 V input | 0.5 mA max. | |
| | | 200 V input | 1 mA max. | |
| | Inrush current (for a cold start at 25°C) *3 | 100 V input | 20 A max. | |
| 200 V input | | 40 A max. | | |
| Noise filter | Yes | | | |
| Output *4 | Voltage adjustment range *5 | -10% to 15% (with V. ADJ) (48-V models: ±10%) | | |
| | Ripple *3 | 2% (p-p) max. | | |
| | Input variation influence | 0.4% max. (with AC input voltage) | | |
| | Load variation influence | 0.8% max. (0 to 100% load, rated input voltage) | | |
| | Temperature variation influence | 0.05%/°C max. (at rated input and output) | | |
| | Startup time | 500 ms max. (up to 90% of output voltage at rated input and output) | | |
| | Hold time *3 | 20 ms min. | | |
| | Additional functions | Overload protection *6 | 105% to 175% of rated load current, voltage drop, intermittent, automatic reset | |
| Overvoltage protection *7 | | Yes | | |
| Overheat protection | | No | | |
| Parallel operation | | No | | |
| Series operation | | Yes (For up to two Power Supplies; external diodes required.) | | |
| Protective circuit operation indicator | | No | | |
| Other | Ambient operating temperature | Refer to the derating curve in <i>Engineering Data</i> on page 13 (with no icing or condensation). | | |
| | Storage temperature | -25 to 65°C (with no icing or condensation) | | |
| | Ambient operating humidity | 25% to 85% (Storage humidity: 25% to 90%) | | |
| | Dielectric strength | 3.0 kVAC for 1 min. (between all inputs and outputs; detection current: 20 mA) | | |
| | | 2.0 kVAC for 1 min. (between all inputs and PE terminals; detection current: 20 mA) | | |
| | | 1.0 kVAC for 1 min. (between all outputs and PE terminals; detection current: 20 mA) | | |
| | Insulation resistance | 100 MΩ min. (between all outputs and all inputs/PE terminals) at 500 VDC | | |
| | Vibration resistance | 10 to 55 Hz, 0.375-mm single amplitude for 2 h each in X, Y, and Z directions | | |
| | Shock resistance | 150 m/s ² , 3 times each in ±X, ±Y, ±Z directions | | |
| | Output indicator | Yes (Color: Green) | | |
| | EMI | Conducted Emissions | Conforms to EN 55011 Group 1 Class A and based on FCC Class A | |
| | | Radiated Emissions | Conforms to EN 55011 Group 1 Class A | |
| | EMS | Electrostatic Discharge | Confirms to EN61000-4-2 | |
| | | Radiated Electromagnetic Field | Confirms to EN61000-4-3 | |
| | | Electrical Fast Transient/Burst | Confirms to EN61000-4-4 | |
| | | Surge | Confirms to EN61000-4-5 | |
| | | Conducted Disturbance | Confirms to EN61000-4-6 | |
| Voltage Dips/Short Interruptions | | Confirms to EN61000-4-11 | | |
| Approved standards *9 | UL Listed: UL 508 (Listing), UL UR: UL 60950-1 (Recognition) | | | |
| | cUL Listed: CSA C22.2 No.107.1 cUR: CSA C22.2 No. 60950-1 | | | |
| | EN/VDE: EN50178 (= VDE 0160), EN 60950-1 (= VDE 0805 Teil 1) (Terminal block: Based on DIN 50274 (VDE 0660-514)) | | | |
| SEMI | SEMI F47-0200 (200-VAC input) | | | |
| Weight *8 | 300 g max. | | 550 g max. | |

*1. When a load is connected that has a built-in DC-DC converter, the overload protection may operate at startup and the Power Supply may not start. Refer to *Overload Protection* on page 15.

*2. Do not use an Inverter output for the Power Supply. Inverters with an output frequency of 50/60 Hz are available, but the rise in the internal temperature of the Power Supply may result in ignition or burning.

*3. Rated input voltage: 100 or 200 VAC at 100% load.

*4. Output characteristics: Specified at power supply output terminals.

*5. If the output voltage adjuster (V. ADJ) is turned, the voltage will increase by more than the allowable voltage range. When adjusting the output voltage, confirm the actual output voltage from the Power Supply and be sure that load is not damaged.

*6. For details, refer to *Overload Protection* on page 15.

*7. To reset the protection, turn OFF the input power for seven minutes or longer and then turn it back ON.

*8. The weight indicated is a for Front-mounting, Open-frame Power Supply.

*9. The range for compliance with EC Directives and safety standards (UL, EN, etc.) is 100 to 240 VAC (85 to 264 VAC).

| Item | Input specification | | 100/200 V switchable | 100 to 240 V input | | |
|--|--|---|---|---|---------------------|--|
| | Power ratings *1 | | 150 W at 5 V | 150 W at 12 V | 150 W at 24 or 48 V | |
| Efficiency | | | 78% min. | 79% min. | 85% min. | |
| Input | Voltage *2 | Switchable between 100 to 120 VAC (allowable range: 85 to 132 VAC) and 200 to 240 VAC (allowable range: 170 to 264 VAC). | | 100 to 240 VAC (allowable range: 85 to 264 VAC) | | |
| | | | | 80 to 370 VDC *9 | | |
| | Frequency *2 | 50/60 Hz (47 to 450 Hz) | | | | |
| | Current *3 | 100 V input | 3.5 A max. | 3.6 A max. | 3.5 A max. | |
| | | 200 V input | 2.1 A max. | 2.2 A max. | 2.1 A max. | |
| | Power factor | --- | | | | |
| | Harmonic current emissions | --- | | | | |
| | Leakage current *3 | 100 V input | 0.5 mA max. | | | |
| | | 200 V input | 1 mA max. | | | |
| | Inrush current (for a cold start at 25°C) *3 | 100 V input | 20 A max. | | | |
| 200 V input | | 40 A max. | | | | |
| Noise filter | Yes | | | | | |
| Output *4 | Voltage adjustment range *5 | | -10% to 15% (with V. ADJ) (48-V models: ±10%) | | | |
| | Ripple *3 | | 2% (p-p) max. | | | |
| | Input variation influence | | 0.4% max. (with AC input voltage) | | | |
| | Load variation influence | | 0.8% max. (0 to 100% load, rated input voltage) | | | |
| | Temperature variation influence | | 0.05%/°C max. (at rated input and output) | | | |
| | Startup time | | 500 ms max. (up to 90% of output voltage at rated input and output) | | | |
| | Hold time *3 | | 20 ms min. | | | |
| Additional functions | Overload protection *6 | | 105% to 175% of rated load current, voltage drop, automatic reset | 105% to 175% of rated load current, voltage drop, intermittent, automatic reset | | |
| | Overvoltage protection *7 | | Yes | | | |
| | Overheat protection | | No | | | |
| | Parallel operation | | No | | | |
| | Series operation | | Yes (For up to two Power Supplies; external diodes required.) | | | |
| Protective circuit operation indicator | | No | | | | |
| Other | Ambient operating temperature | | Refer to the derating curve in <i>Engineering Data</i> on page 13 (with no icing or condensation). | | | |
| | Storage temperature | | -25 to 65°C (with no icing or condensation) | | | |
| | Ambient operating humidity | | 25% to 85% (Storage humidity: 25% to 90%) | | | |
| | Dielectric strength | | 3.0 kVAC for 1 min. (between all inputs and outputs; detection current: 20 mA) 2.0 kVAC for 1 min. (between all inputs and PE terminals; detection current: 20 mA) 1.0 kVAC for 1 min. (between all outputs and PE terminals; detection current: 20 mA) | | | |
| | Insulation resistance | | 100 MΩ min. (between all outputs and all inputs/PE terminals) at 500 VDC | | | |
| | Vibration resistance | | 10 to 55 Hz, 0.375-mm single amplitude for 2 h each in X, Y, and Z directions | | | |
| | Shock resistance | | 150 m/s ² , 3 times each in ±X, ±Y, ±Z directions | | | |
| | Output indicator | | Yes (Color: Green) | | | |
| | EMI | Conducted Emissions | | Conforms to EN 55011 Group 1 Class A and based on FCC Class A | | |
| | | Radiated Emissions | | Conforms to EN 55011 Group 1 Class A | | |
| | EMS | Electrostatic Discharge | | Confirms to EN61000-4-2 | | |
| | | Radiated Electromagnetic Field | | Confirms to EN61000-4-3 | | |
| | | Electrical Fast Transient/Burst | | Confirms to EN61000-4-4 | | |
| | | Surge | | Confirms to EN61000-4-5 | | |
| Conducted Disturbance | | Confirms to EN61000-4-6 | | | | |
| Voltage Dips/Short Interruptions | | Confirms to EN61000-4-11 | | | | |
| Approved standards *9 | | UL Listed: UL 508 (Listing), UL UR: UL 60950-1 (Recognition) cUL Listed: CSA C22.2 No.107.1 cUR: CSA C22.2 No. 60950-1 EN/VDE: EN50178 (= VDE 0160), EN 60950-1 (= VDE 0805 Teil 1) (Terminal block: Based on DIN 50274 (VDE 0660-514)) | | | | |
| SEMI | | --- | | | | |
| Weight *8 | | 800 g max. | 700 g max. | 600 g max. | | |

*1. When a load is connected that has a built-in DC-DC converter, the overload protection may operate at startup and the Power Supply may not start. Refer to *Overload Protection* on page 15.

*2. Do not use an Inverter output for the Power Supply. Inverters with an output frequency of 50/60 Hz are available, but the rise in the internal temperature of the Power Supply may result in ignition or burning.

*3. Rated input voltage: 100 or 200 VAC at 100% load.

*4. Output characteristics: Specified at power supply output terminals.

*5. If the output voltage adjuster (V. ADJ) is turned, the voltage will increase by more than the allowable voltage range. When adjusting the output voltage, confirm the actual output voltage from the Power Supply and be sure that load is not damaged.

*6. For details, refer to *Overload Protection* on page 15.

*7. To reset the protection, turn OFF the input power for seven minutes or longer and then turn it back ON.

*8. The weight indicated is a for Front-mounting, Open-frame Power Supply.

*9. The range for compliance with EC Directives and safety standards (UL, EN, etc.) is 100 to 240 VAC (85 to 264 VAC).

| Item | Input specification Power ratings *1 | | 100/200 V (Selected) | | |
|--|---|---------------------------------|---|---|--|
| | | | 300 W | 600 W | |
| Efficiency | | | 82% min. | 80% min. | |
| Input | Voltage *2 | | 100 to 120 VAC (allowable range: 85 to 132 VAC) 200 to 240 VAC (allowable range: 170 to 264 VAC) (Switchable) | | |
| | Frequency *2 | | 50/60 Hz (47 to 450 Hz) | | |
| | Current *3 | 100 V input | 8 A max. | 14 A max. | |
| | | 200 V input | 4.5 A max. | 8 A max. | |
| | Power factor | | --- | | |
| | Harmonic current emissions | | --- | | |
| | Leakage current *3 | 100 V input | 0.5 mA max. | | |
| | | 200 V input | 1 mA max. | | |
| Inrush current (for a cold start at 25°C) *3 | 100 V input | 25 A max. | 30 A max. | | |
| | 200 V input | 50 A max. | 60 A max. | | |
| Noise filter | | Yes | | | |
| Output *4 | Voltage adjustment range *5 | | -10% to 15% (with V. ADJ) | | |
| | Ripple *3 | | 2% (p-p) max. | | |
| | Input variation influence | | 0.4% max. | | |
| | Load variation influence | | 0.8% max. (0 to 100% load, rated input voltage) | | |
| | Temperature variation influence | | 0.05%/°C max. | | |
| | Startup time | | 650 ms max. | 500 ms max. | |
| | Hold time *3 | | 20 ms min. | | |
| Additional functions | Overload protection *6 | | 105% to 175% of rated load current, voltage drop, intermittent, automatic reset | 105% to 175% of rated load current, Inverted L voltage drop, the circuit will be shut OFF when the overload exceeds 5 s. *9 | |
| | Overvoltage protection *7 | | Yes | Yes *9 | |
| | Overheat protection | | No | Yes *9 | |
| | Parallel operation | | Yes (up to 5 units) | | |
| | Series operation | | Yes (For up to two Power Supplies; external diodes required.) | | |
| Protective circuit operation indicator | | No | Yes (color: red) | | |
| Other | Ambient operating temperature | | Refer to the derating curve in <i>Engineering Data</i> on page 13 (with no icing or condensation). | | |
| | Storage temperature | | -25 to 65°C (with no icing or condensation) | | |
| | Ambient operating humidity | | 25% to 85% (Storage humidity: 25% to 90%) | | |
| | Dielectric strength | | 3.0 kVAC for 1 min. (between all inputs and outputs; detection current: 25 mA) 2.0 kVAC for 1 min. (between all inputs and PE terminals; detection current: 25 mA) 1.0 kVAC for 1 min. (between all outputs and PE terminals; detection current: 25 mA) | | |
| | Insulation resistance | | 100 MΩ min. (between all outputs and all inputs/PE terminals) at 500 VDC | | |
| | Vibration resistance | | 10 to 55 Hz, 0.375-mm single amplitude for 2 h each in X, Y, and Z directions | | |
| | Shock resistance | | 150 m/s ² , 3 times each in ±X, ±Y, ±Z directions | | |
| | Output indicator | | Yes (Color: Green) | | |
| | EMI | Conducted Emissions *3 | | Conforms to EN 55011 Group 1 Class A and based on FCC Class A | |
| | | Radiated Emissions | | Conforms to EN 55011 Group 1 Class A | |
| | EMS | Electrostatic Discharge | | Confirms to EN61000-4-2 | |
| | | Radiated Electromagnetic Field | | Confirms to EN61000-4-3 | |
| | | Electrical Fast Transient/Burst | | Confirms to EN61000-4-4 | |
| | | Surge | | Confirms to EN61000-4-5 | |
| | | Conducted Disturbance | | Confirms to EN61000-4-6 | |
| | Voltage Dips/Short Interruptions | | Confirms to EN61000-4-11 | | |
| | Approved standards *10 | | UL UR: UL 508 (Recognition), UL UR: UL 60950-1 (Recognition) cUL Listed: CSA C22.2 No.107.1 cUR: CSA C22.2 No. 60950-1 EN/VDE: EN50178 (= VDE 0160), EN 60950-1 (= VDE 0805 Teil 1) (Terminal block: Based on DIN 50274 (VDE 0660-514)) | | |
| SEMI | | SEMI F47-0200 (200-VAC input) | | | |
| Weight *8 | | 1,600 g max. | 2,500 g max. | | |

*1. When a load is connected that has a built-in DC-DC converter, the overload protection may operate at startup and the Power Supply may not start. Refer to *Overload Protection* on page 15.

*2. Do not use an Inverter output for the Power Supply. Inverters with an output frequency of 50/60 Hz are available, but the rise in the internal temperature of the Power Supply may result in ignition or burning.

*3. Rated input voltage: 100 or 200 VAC at 100% load.

*4. Output characteristics: Specified at power supply output terminals.

*5. If the output voltage adjuster (V. ADJ) is turned, the voltage will increase by more than the allowable voltage range. When adjusting the output voltage, confirm the actual output voltage from the Power Supply and be sure that load is not damaged.

*6. For details, refer to *Overload Protection* on page 15.

*7. To reset the protection, turn OFF the input power for three minutes or longer and then turn it back ON.

*8. The weight indicated is a for Front-mounting, Open-frame Power Supply.

*9. The protection-ON alarm indicator will light as soon as the output is interrupted. For resetting, turn OFF the input power, leave for more than three minutes, and then turn it back ON again.

*10. The range for compliance with EC Directives and safety standards (UL, EN, etc.) is 100 to 240 VAC (85 to 264 VAC).

S8JX

Connections

Block Diagrams

S8JX-G01505□□ (15 W)

S8JX-G01512□□ (15 W)

S8JX-G01515□□ (15 W)

S8JX-G01524□□ (15 W)

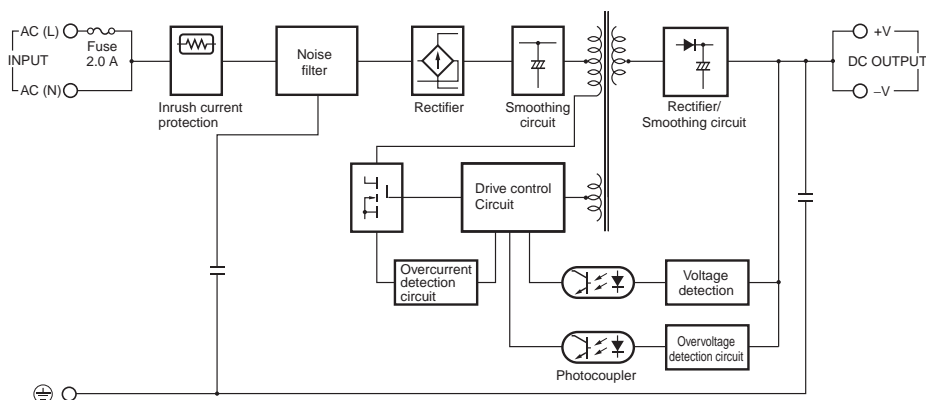

S8JX-G01548□□ (15 W)

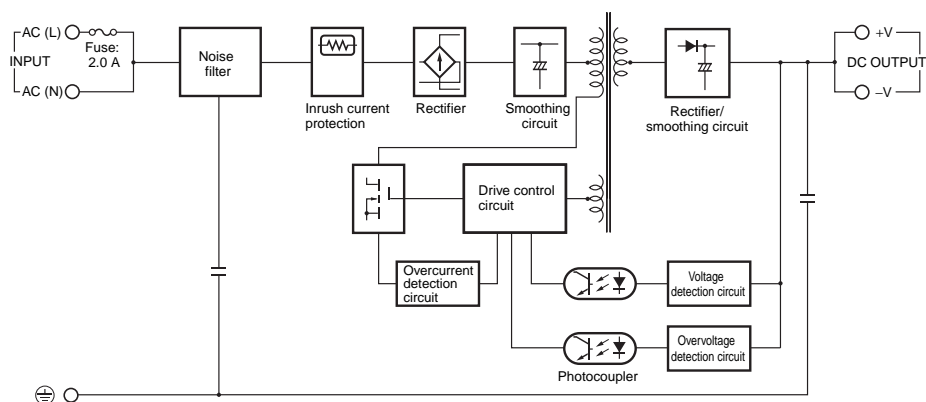

S8JX-G03505□□ (35 W)

S8JX-G03512□□ (35 W)

S8JX-G03515□□ (35 W)

S8JX-G03524□□ (35 W)

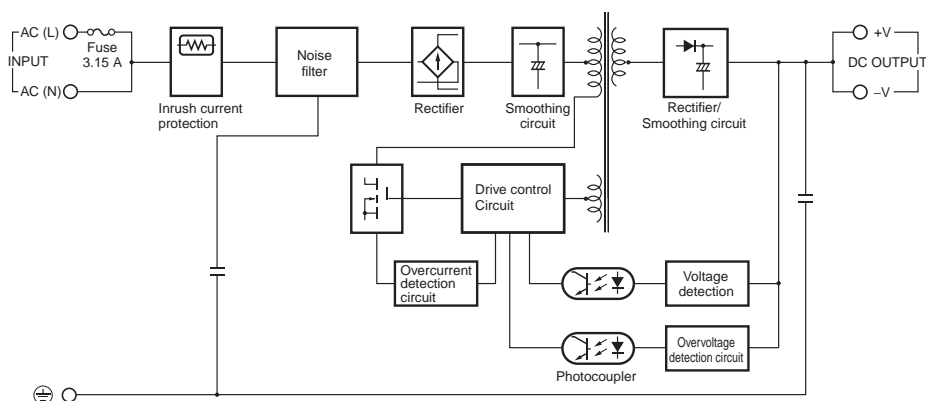

S8JX-G03548□□ (35 W)

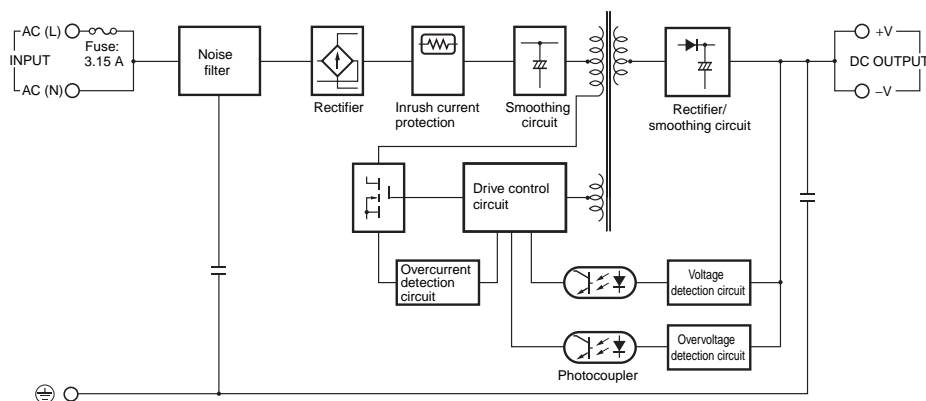

S8JX

S8JX-G05005 (50 W)

S8JX-G05012 (50 W)

S8JX-G05024 (50 W)

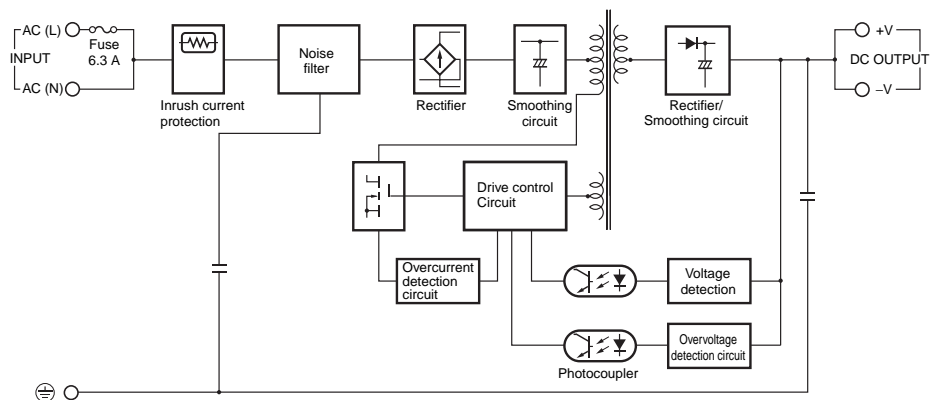

S8JX-G05048 (50 W)

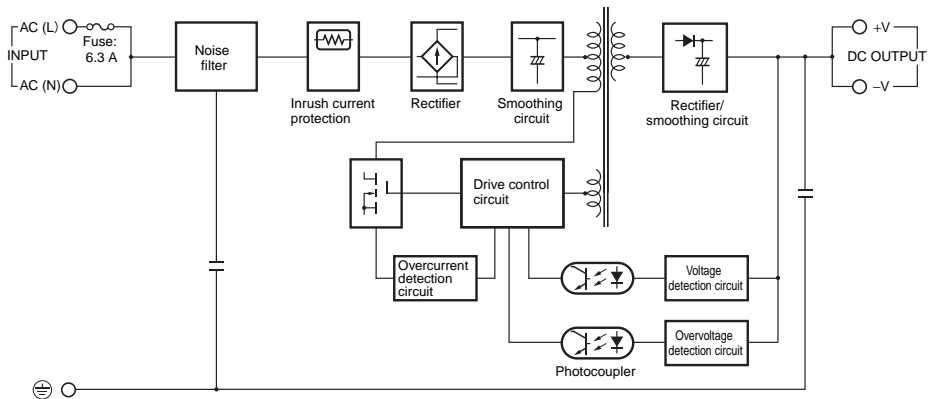

S8JX-G100 (100 W)

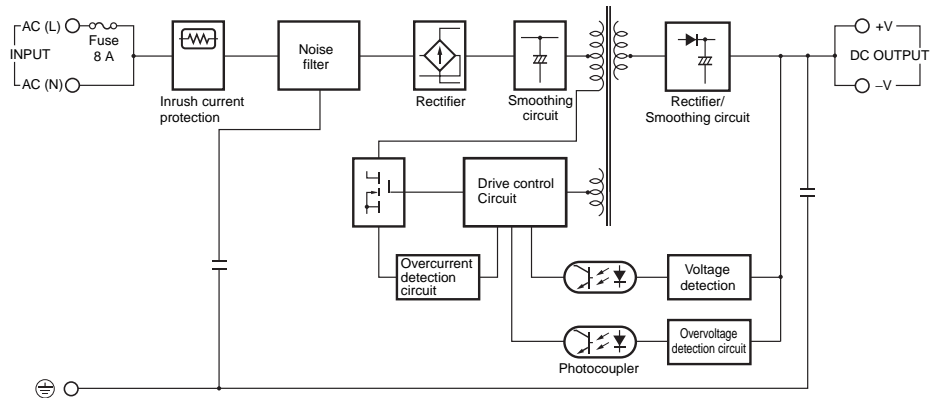

S8JX

S8JX-G15005 (150 W)

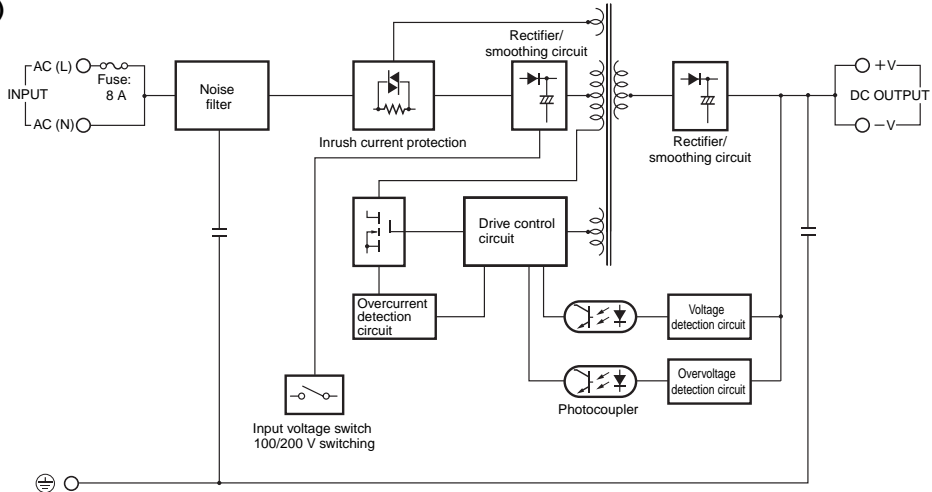

Note: Set the input voltage switch to "115V" for 100 to 120 VAC and to "230V" for 200 to 240 VAC.

S8JX-G15012 (150 W)

S8JX-G15024 (150 W)

S8JX-G15048 (150 W)

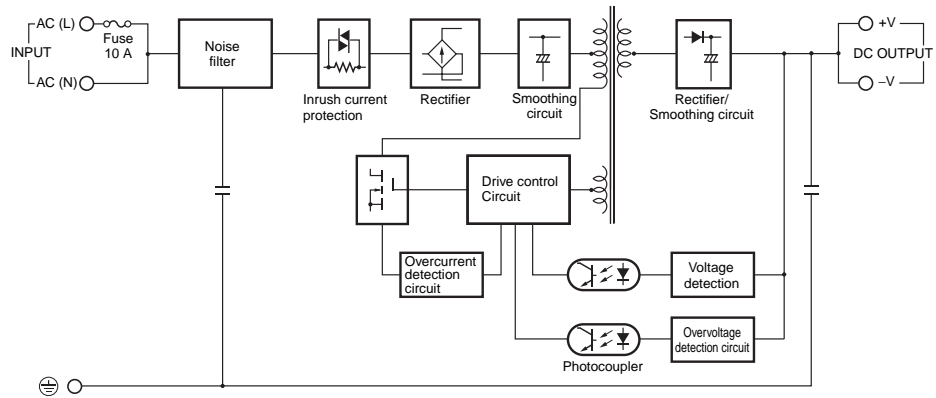

S8JX-G30024□□ (300 W)

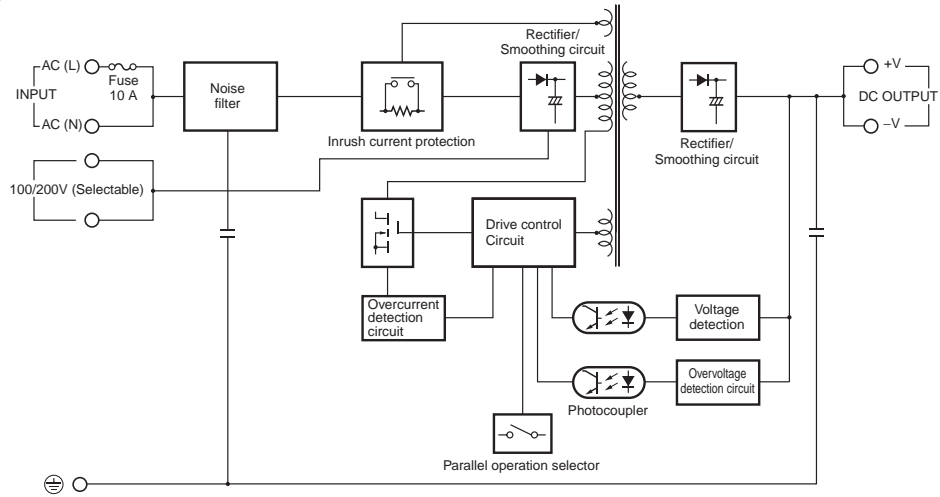

Note: Short-circuit the input voltage selector terminals if the input is 100 to 120 VAC. Keep the terminals open if the input is 200 to 240 VAC.

S8JX-G60024□□ (600 W)

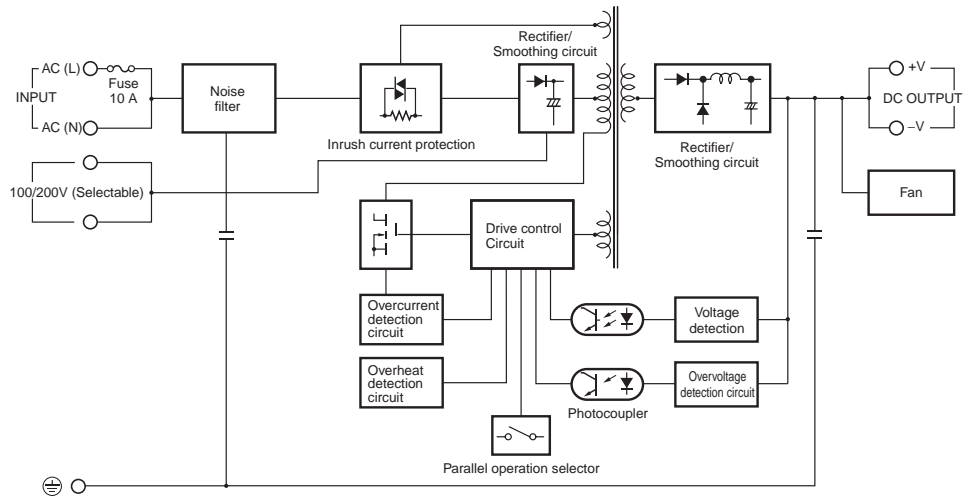

Note: Short-circuit the input voltage selector terminals if the input is 100 to 120 VAC. Keep the terminals open if the input is 200 to 240 VAC.

S8JX

Construction and Nomenclature

Nomenclature

15-/35-/50-/100-/150-W Models

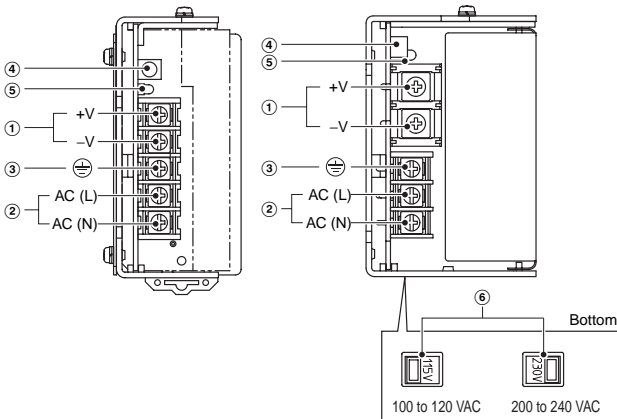

Note: The S8JX-G05024CD is shown above.

Note: The S8JX-G15005C is shown above.

| No. | Name | Function |
|-----|------------------------------------|--|
| 1 | DC Output Terminals (-V), (+V) | Connect the load lines to these terminals. |
| 2 | AC Input Terminals (L), (N) | Connect the input lines to these terminals. *1 |
| 3 | Protective Earth Terminal (PE) (⊕) | Connect the ground line to these terminals. *2 |
| 4 | Output Voltage Adjuster (V. ADJ) | Use to adjust the voltage. |
| 5 | Output Indicator (DC ON: Green) | Lights green while a direct current (DC) output is ON. |
| 6 | Input voltage switch | Switches the internal circuits according to the input voltage. "115V": 100 to 120 VAC "230V": 200 to 240 VAC |

*1. The fuse is located on the (L) side. It is NOT user-replaceable. For a DC power input, connect the low side to the positive (+) terminal.

*2. This is the protective earth terminal specified in the safety standards. Always ground this terminal.

300-W Model

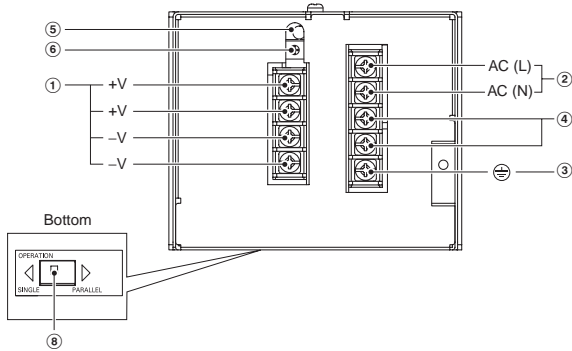

600-W Model

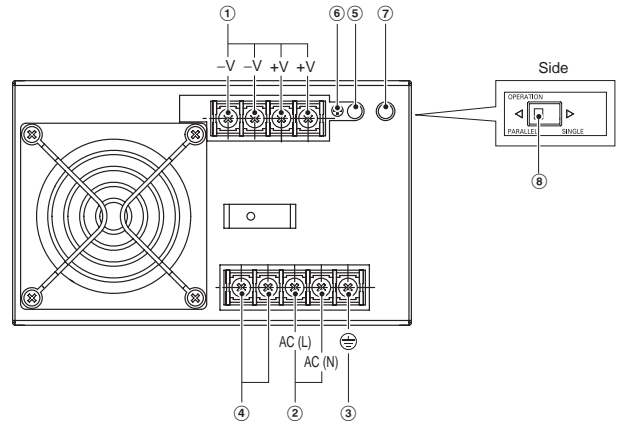

| No. | Name | Function |
|-----|--|--|
| 1 | DC Output Terminals (+V), (-V) | Connect the load lines to these terminals. |
| 2 | AC Input Terminals (L), (N) | Connect the input lines to these terminals. *1 |
| 3 | Protective Earth Terminal (PE) (⊕) | Connect the ground line to these terminals. *2 |
| 4 | Input Voltage Selector Terminals | Short-circuit the terminals if the input is 100 to 120 VAC and open the terminals if the input is 200 to 230 VAC. |
| 5 | Output Indicator (DC ON: Green) | Lights while a Direct Current (DC) output is ON. |
| 6 | Output Voltage Adjuster (V. ADJ) | It is possible to increase or decrease the output voltage. |
| 7 | Protection-ON Alarm Indicator (DC ON: Red) | The red indicator will be lit if the overvoltage (for a 600-W model) or overheat protection (for a 600-W model) circuit is triggered. This indicator will also be lit when overload (for a 600-W model) is detected. |
| 8 | Selector of Parallel Operation | Set the selector to PARALLEL if the Units are in parallel operation. |

*1. The fuse is located on the (L) side. It is NOT user-replaceable.

*2. This is the protective earth terminal specified in the safety standards. Always ground this terminal.

Reference Values

| | | |
|---------------------------|---|--------------|
| Reliability (MTBF) | S8JX-G15012□□ and S8JX-G15005□□ | Other models |
| | 240,000 hrs | 250,000 hrs |
| Definition | MTBF stands for Mean Time Between Failures, which is calculated according to the probability of accidental device failures, and indicates reliability of devices. Therefore, it does not necessarily represent a life of the product. | |
| Life expectancy | 10 yrs. min. | |
| Definition | The life expectancy indicates average operating hours under the ambient temperature of 40°C and a load rate of 50%. Normally this is determined by the life expectancy of the built-in aluminum electrolytic capacitor. | |

Engineering Data

Derating Curves (Standard Mounting)

15-/35-/50-/100-/150-W Models

Open-frame Power Supplies

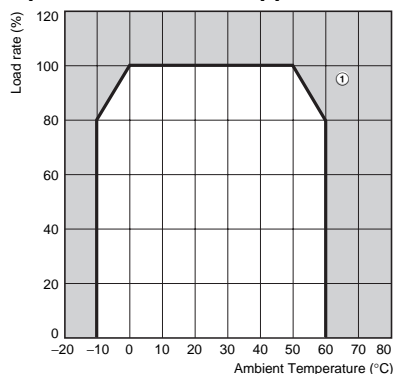

Covered Power Supplies

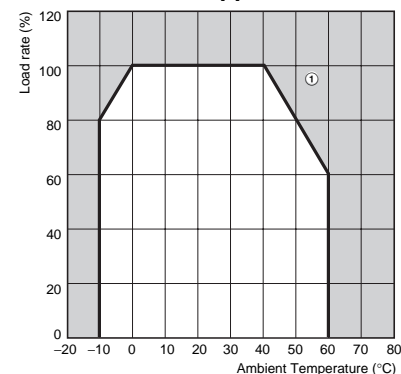

Note: 1. Internal parts may occasionally deteriorate or be damaged. Do not use the Power Supply in areas outside the derating curve (i.e., the area shown by shading ① in the above graph).

2. If there is a derating problem, use forced air-cooling.

3. For Customers Using a DC Input

When using an input voltage of less than 100 VDC, reduce the load calculated with the above derating curve by at least the following coefficients.

35-W and 100-W (5-V or 12-V output) models: 0.8

50-W/150-W models:

0.85 (DC power cannot be input only to the S8JX-G15005□□.)

15-W and 100-W (24-V or 48-V output):

0.9

300-/600-W Models

Single Unit Operation

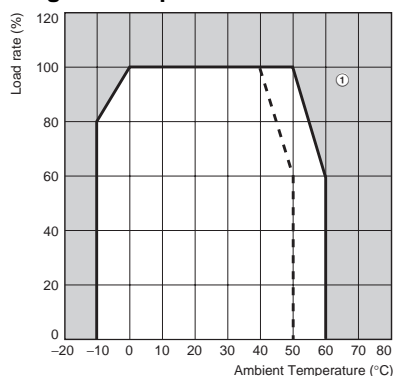

Parallel Operation

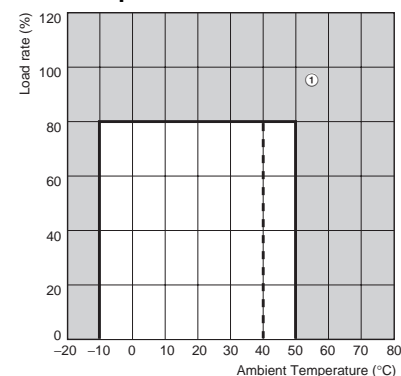

— Solid line Front-mounting,
Bottom-mounting,
DIN Rail mounting,
Side mounting (600W)

- - - Dotted line Side mounting (300W)

Note: 1. Internal parts may occasionally deteriorate or be damaged. Do not use the Power Supply in areas outside the derating curve (i.e., the area shown by shading ① in the above graph).

2. If there is a derating problem, use forced air-cooling.

Mounting

15-/35-/50-/100-/150-W Models

The following three mounting methods are possible.

A. Front-mounting: Refer to *Mounting Bracket Provided with Front-mounting Power Supplies* (A) on page 20.

B. Bottom-mounting

C. Side-mounting

Note: Additional mounting methods are also available using DIN Rail-mounting models.

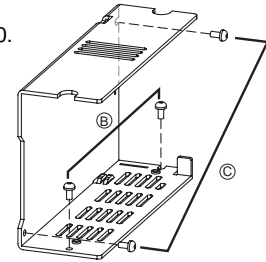

Standard Mounting

15-/35-/50-/100-/150-W Models

Front-mounting

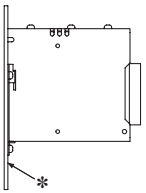

DIN Rail-mounting

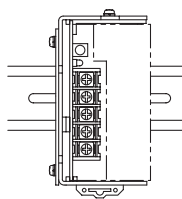

Bottom-mounting

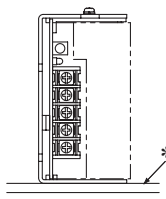

Vertical Side-mounting

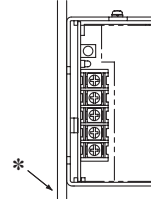

Horizontal Side-mounting

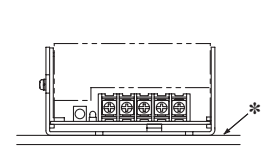

- Note:**
1. Improper mounting will interfere with heat dissipation and may occasionally result in deterioration or damage of internal parts. Use the standard mounting method only.
 2. When mounting the Power Supply, mounting it to a metal plate (*) is recommended.
 3. Install the Power Supply so that the air flow circulates around the Power Supply, as the Power Supply is designed to radiate heat by means of natural air flow.

300-W Model

Front-mounting

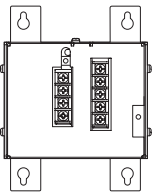

Bottom-mounting

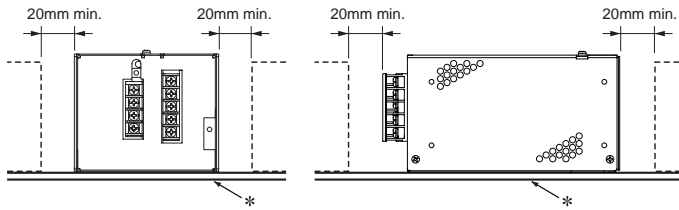

Side-mounting

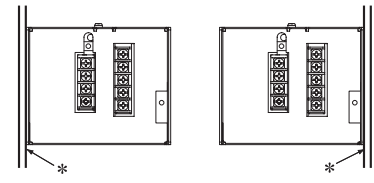

DIN Rail mounting

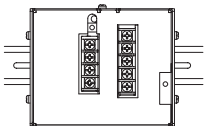

- Note:**
1. Improper mounting will interfere with heat dissipation and may occasionally result in deterioration or damage of internal parts. Use the standard mounting method only.
 2. When mounting the Power Supply, mounting it to a metal plate (*) is recommended.
 3. Install the Power Supply so that the air flow circulates around the Power Supply, as the Power Supply is designed to radiate heat by means of natural air flow.

600-W Model

Front-mounting

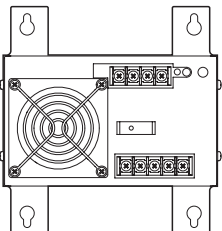

Bottom-mounting

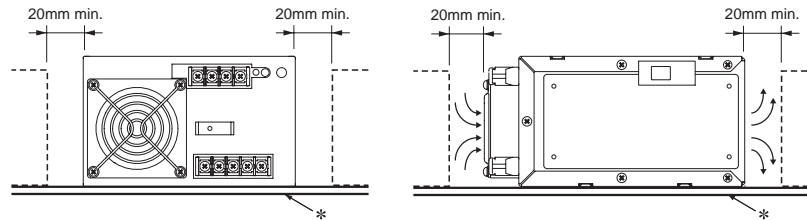

Side-mounting

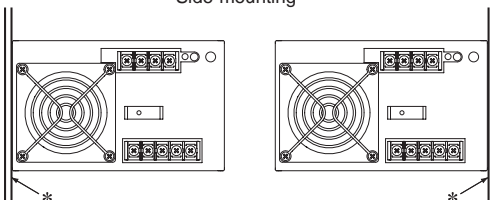

- Note:**
1. Improper mounting will interfere with heat dissipation and may occasionally result in deterioration or damage of internal parts. Use the standard mounting method only.
 2. When mounting the Power Supply, mounting it to a metal plate (*) is recommended.
 3. Install the Power Supply so that the air flow circulates around the Power Supply, as the Power Supply is designed to radiate heat by means of natural air flow.

Overload Protection

The Power Supply is provided with an overload protection function that protects the power supply from possible damage by overcurrent. When the output current rises above 105% to 175% min. of the rated current, the protection function is triggered, decreasing the output voltage. When the output current falls within the rated range, the overload protection function is automatically cleared.

(Reference value)

15-/35-/50-/100-/150-W (12-/24-/48-V) Models

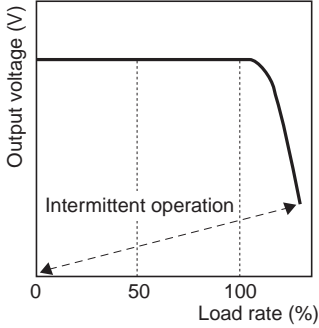

600-W Model

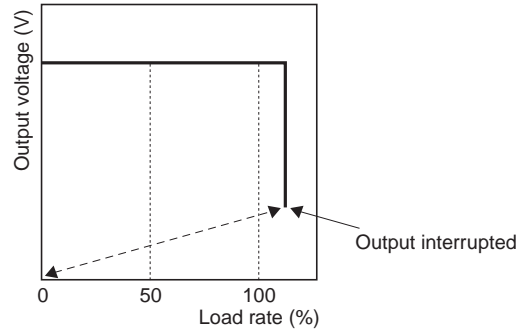

150-W, 5-V Models

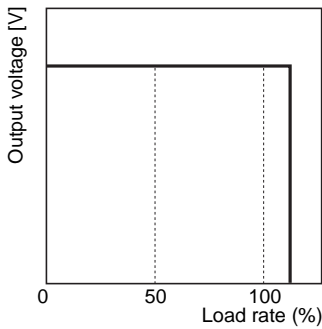

300-W Model

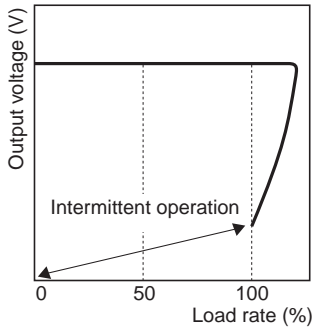

If an excessive current flows for 5 s or more, the output will be turned OFF and simultaneously the protection-ON alarm indicator will be lit. To reset the S8JX, turn OFF the power, leave the S8JX for at least three minutes, and then turn it ON again.

- Note:**
1. When a load is connected that has a built-in DC-DC converter, the overload protection may operate at startup and the power supply may not start.
 2. Internal parts may occasionally deteriorate or be damaged if a short-circuited or overcurrent state continues during operation.
 3. Internal parts may possibly deteriorate or be damaged if the Power Supply is used for applications with frequent inrush current or overloading at the load end. Do not use the Power Supply for such applications.

Overvoltage Protection

15-/35-/50-/100-/150-W Models

Consider the possibility of an overvoltage and design the system so that the load will not be subjected to an excessive voltage even if the feedback circuit in the power supply fails. When an excessive voltage that is approximately 130% of the rated voltage or more is output, the output voltage is shut OFF, preventing damage to the load due to overvoltage. Reset the input power by turning it OFF for at least seven minutes and then turning it back ON again.

300-/600-W Models

Consider the possibility of an overvoltage and design the system so that the load will not be subjected to an excessive voltage even if the feedback circuit in the Power Supply fails. When an excessive voltage that is approximately 120% of the rated voltage or more is output, the output voltage is shut OFF, preventing damage to the load due to overvoltage. Reset the input power by turning it OFF for at least three minute and then turning it back ON again.

(Reference value)

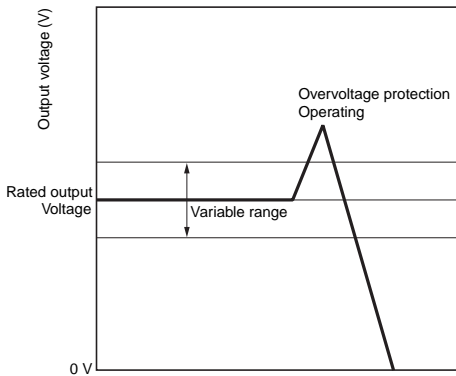

Note: Do not turn ON the power again until the cause of the overvoltage has been removed.

Overheat Protection

600-W Model

If the internal temperature rises excessively as a result of fan failure or any other reason, the overheat protection circuit will be triggered to shut OFF the output voltage and simultaneously the protection-ON alarm indicator will be lit. Reset the input power by turning it OFF for at least three minutes and then turning it back ON again.

Inrush Current, Startup Time, Output Hold Time

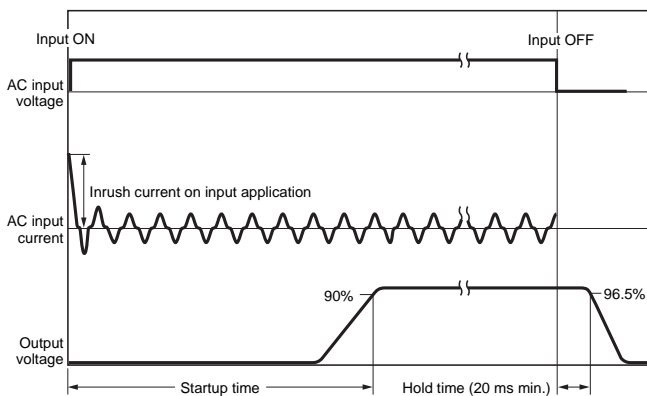

Note: A maximum startup time of 500 ms is required (650 ms for 300 W). Construct a system configuration that considers the startup time of other devices.

Dimensions

Front-mounting Models

- S8JX-G015□□ (15 W)
- S8JX-G015□□C (15 W)
- S8JX-G035□□ (35 W)
- S8JX-G035□□C (35 W)

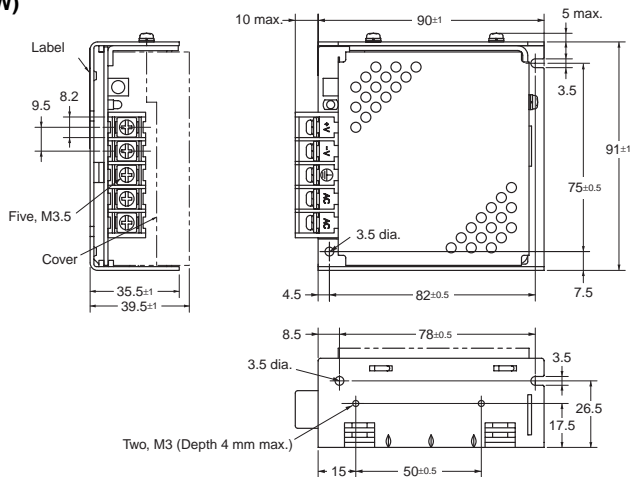

Panel mounting holes dimensions

| | Surface screw mounting |
|-----------------|------------------------|
| Side Mounting | |
| Bottom Mounting | |

- S8JX-G050□□ (50 W)
- S8JX-G050□□C (50 W)

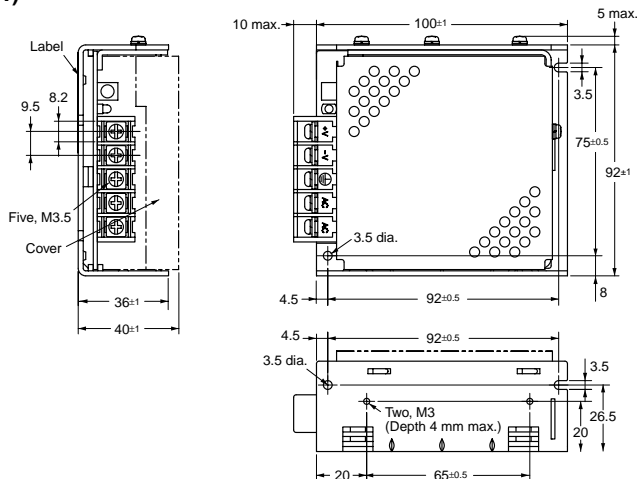

Panel mounting holes dimensions

| | Surface screw mounting |
|-----------------|------------------------|
| Side Mounting | |
| Bottom Mounting | |

- S8JX-G100□□ (100 W)
- S8JX-G100□□C (100 W)
- S8JX-G15024 (150 W)
- S8JX-G15024C (150 W)
- S8JX-G15048 (150 W)
- S8JX-G15048C (150 W)

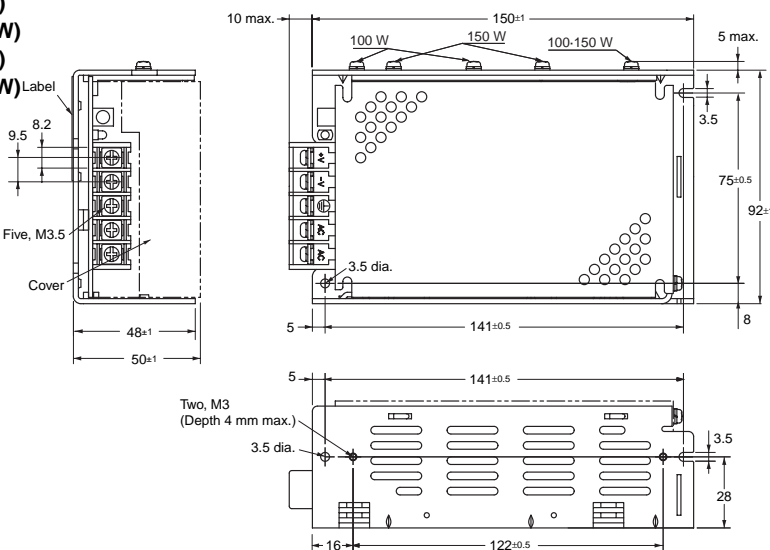

Panel mounting holes dimensions

| | Surface screw mounting |
|-----------------|------------------------|
| Side Mounting | |
| Bottom Mounting | |

S8JX

S8JX-G15005 (150 W) S8JX-G15005C (150 W)

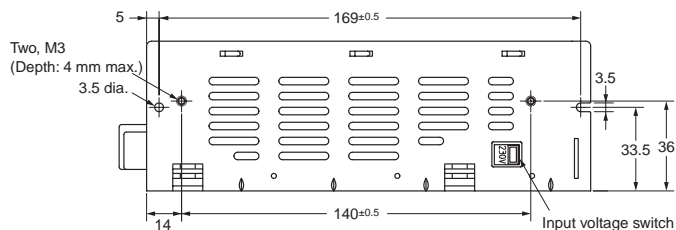
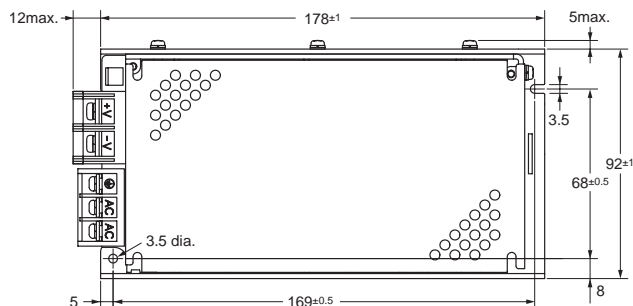
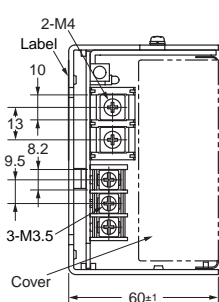

Panel mounting holes dimensions

| Surface screw mounting | |
|------------------------|---------|
| Side Mounting | Two, M3 |
| | 68±0.5 |
| Bottom Mounting | Two, M3 |
| | 169±0.5 |

S8JX-G15012 (150 W) S8JX-G15012C (150 W)

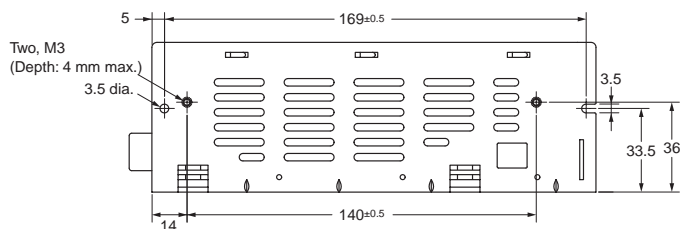
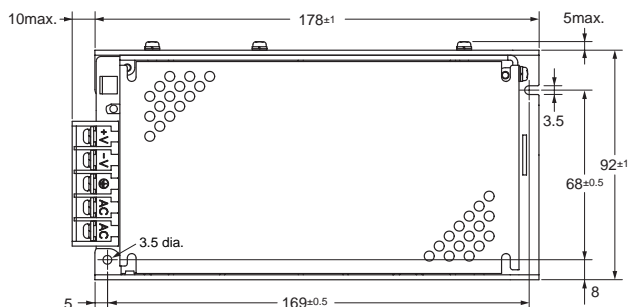
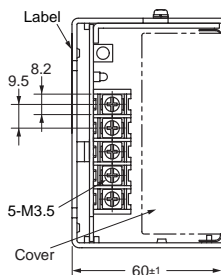

Panel mounting holes dimensions

| Surface screw mounting | |
|------------------------|---------|
| Side Mounting | Two, M3 |
| | 68±0.5 |
| Bottom Mounting | Two, M3 |
| | 169±0.5 |

S8JX

S8JX-G30024C (300 W)

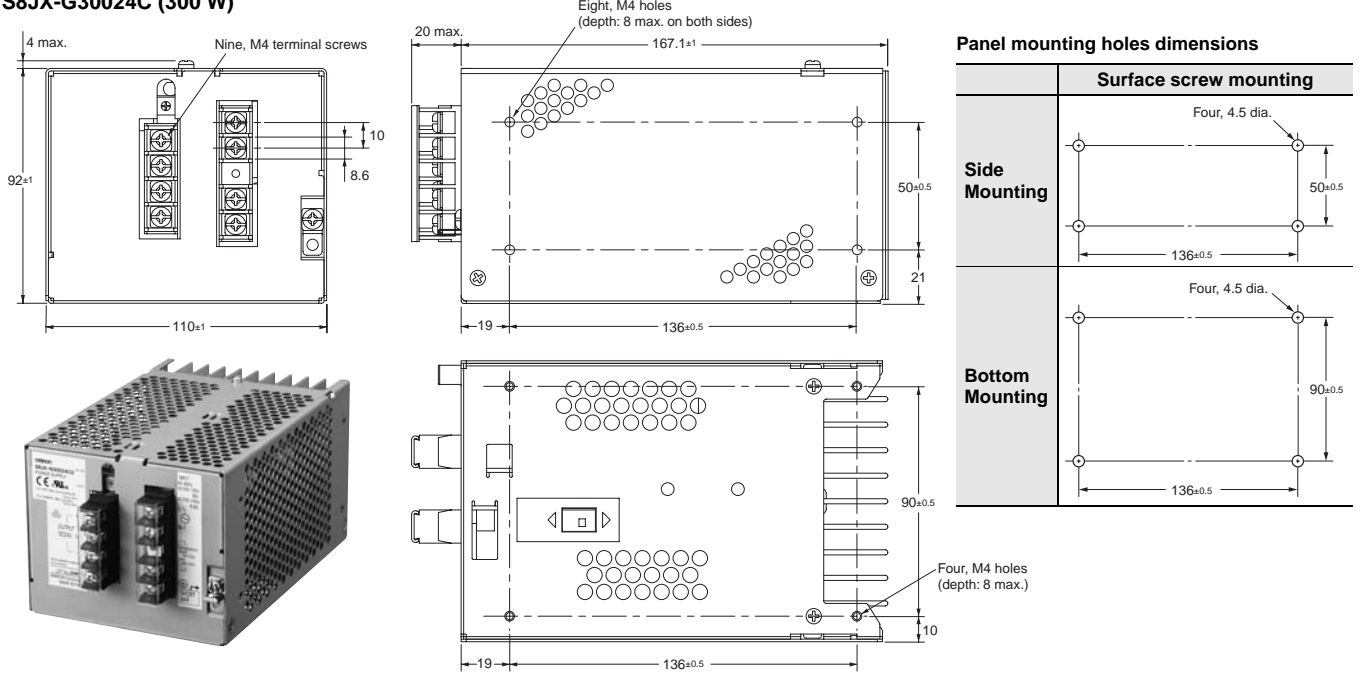

S8JX-G60024C (600 W)

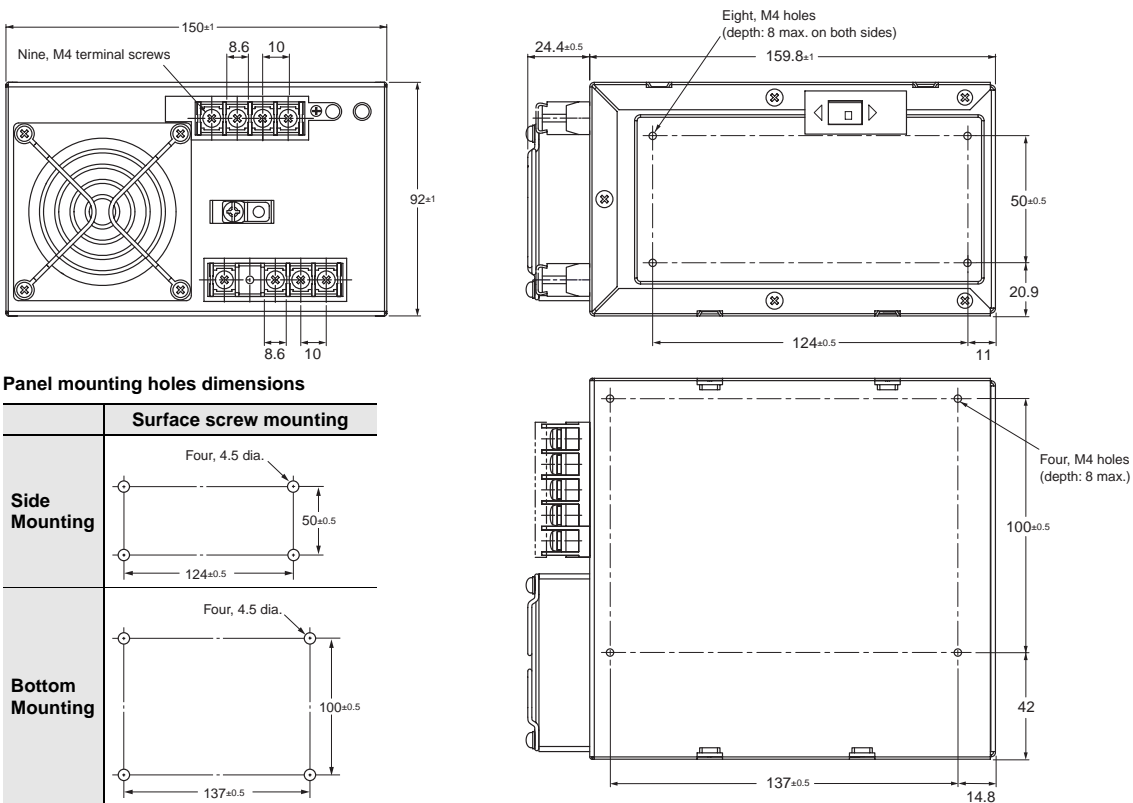

Mounting Bracket Provided with Front-mounting Power Supplies (A)

15-/35-/50-/100-/150-W Models

S82Y-J00F Front-mounting Bracket

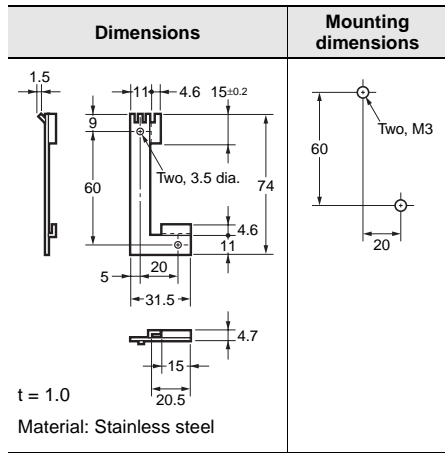

Front-mounting Method

Temporarily attach the enclosed mounting bracket as shown in the illustration on the right, hook the holes (parts a) in the Power Supply on hooks on the mounting bracket (parts b), and secure the Power Supply with two mounting screws.

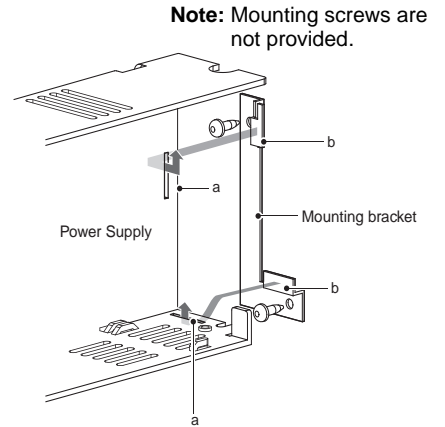

300-/600-W Models

Front-mounting Bracket (S82Y-J30F)

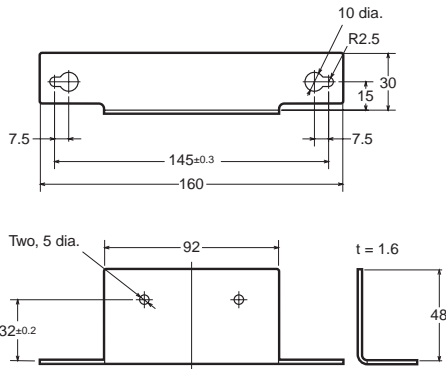

Note: Mounting Brackets are provided in a set, one for the right side and one for the left side.

Dimensions with Mounting Brackets

300-W Model

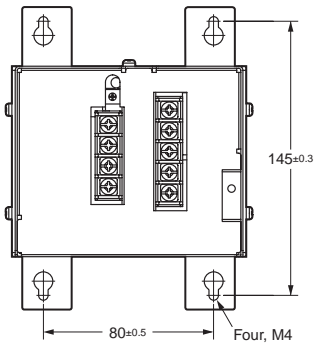

Attaching the Mounting Brackets

300-W Model

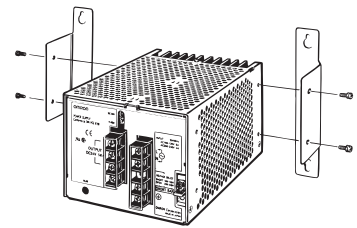

Note: To provide ventilation space, the body will shift forward by 21.6 mm from the mounting surface.

600-W Model

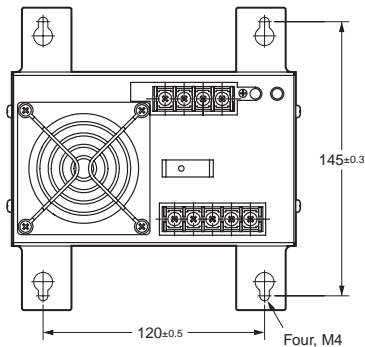

600-W Model

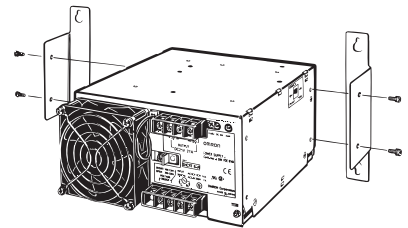

Note: To provide ventilation space, the body will shift forward by 23.6 mm from the mounting surface.

DIN Rail-mounting Models

- S8JX-G015□□D (15 W)
- S8JX-G015□□CD (15 W)
- S8JX-G035□□D (35 W)
- S8JX-G035□□CD (35 W)

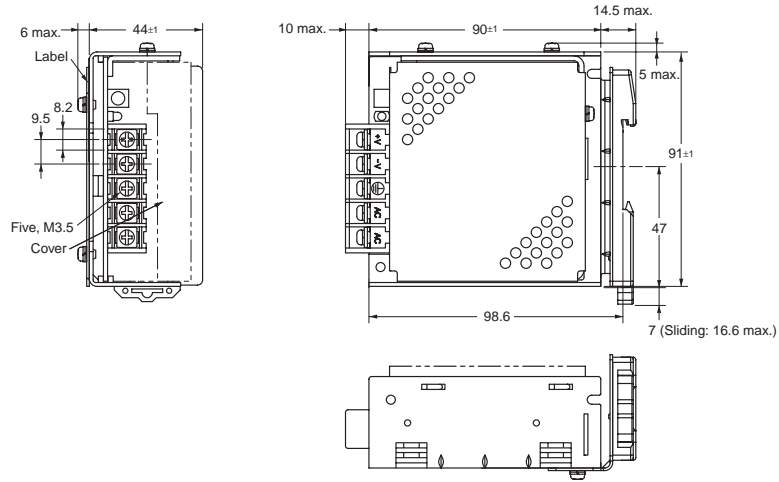

- S8JX-G050□□D (50 W)
- S8JX-G050□□CD (50 W)

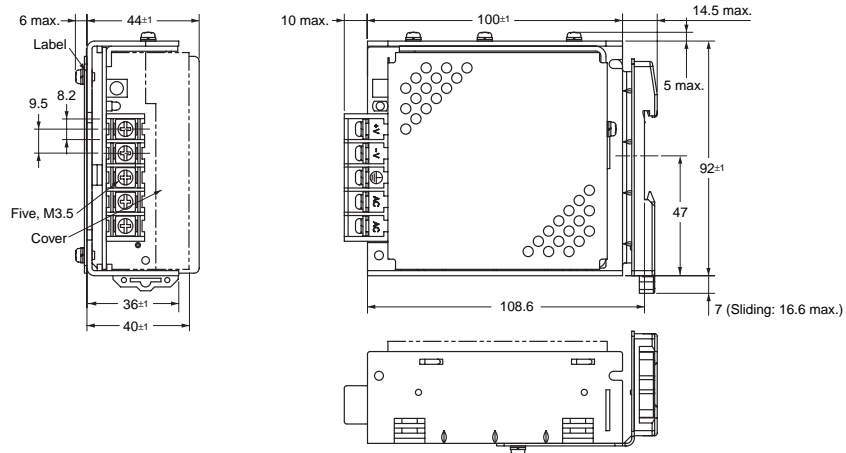

- S8JX-G100□□D (100 W)
- S8JX-G100□□CD (100 W)
- S8JX-G15024D (150 W)
- S8JX-G15024CD (150 W)
- S8JX-G15048D (150 W)
- S8JX-G15048CD (150 W)

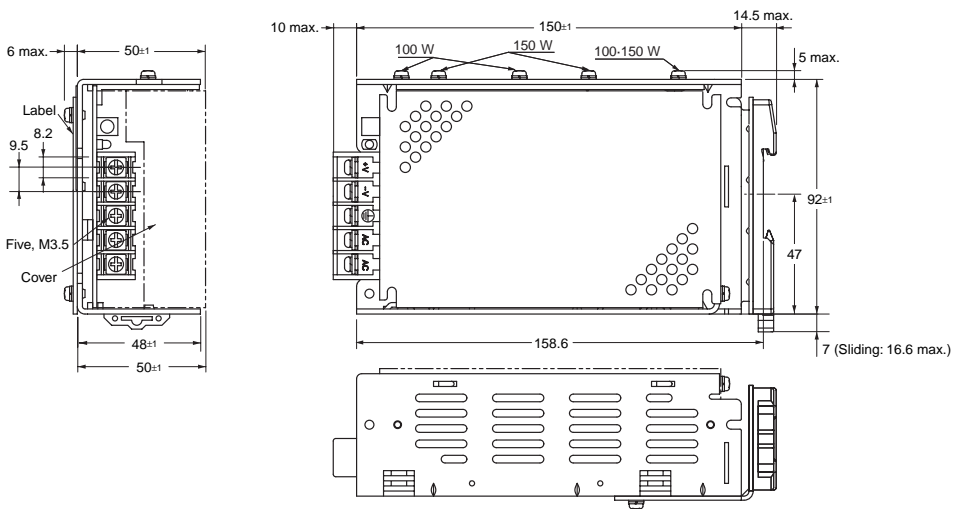

S8JX

S8JX-G15005D (150 W)
S8JX-G15005CD (15 W)

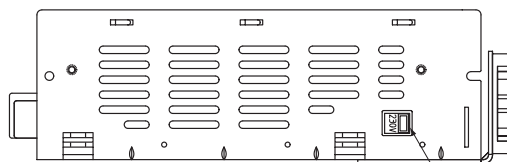
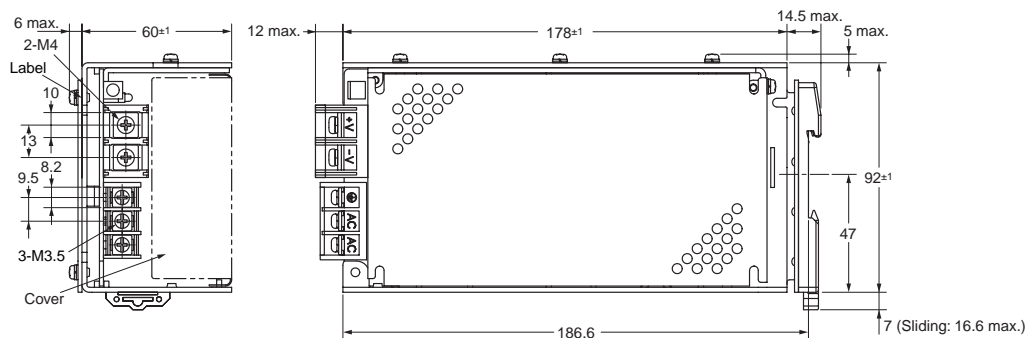

Input voltage switch

S8JX-G15012D (150 W)
S8JX-G15012CD (150 W)

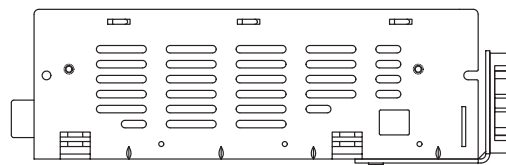
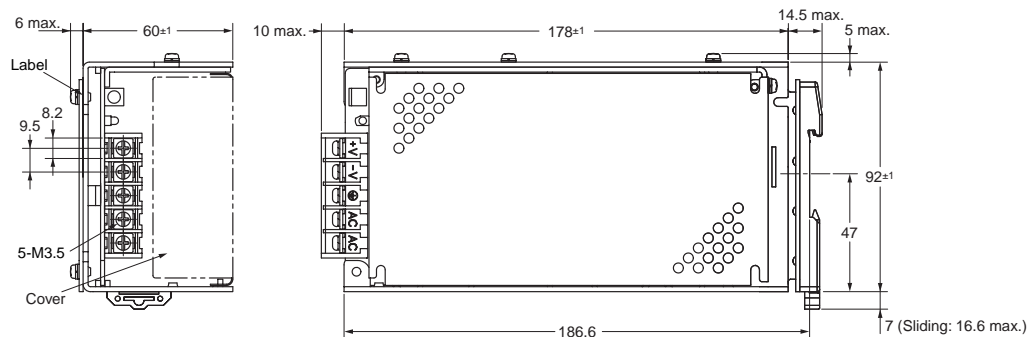

S8JX-G30024CD (300 W)

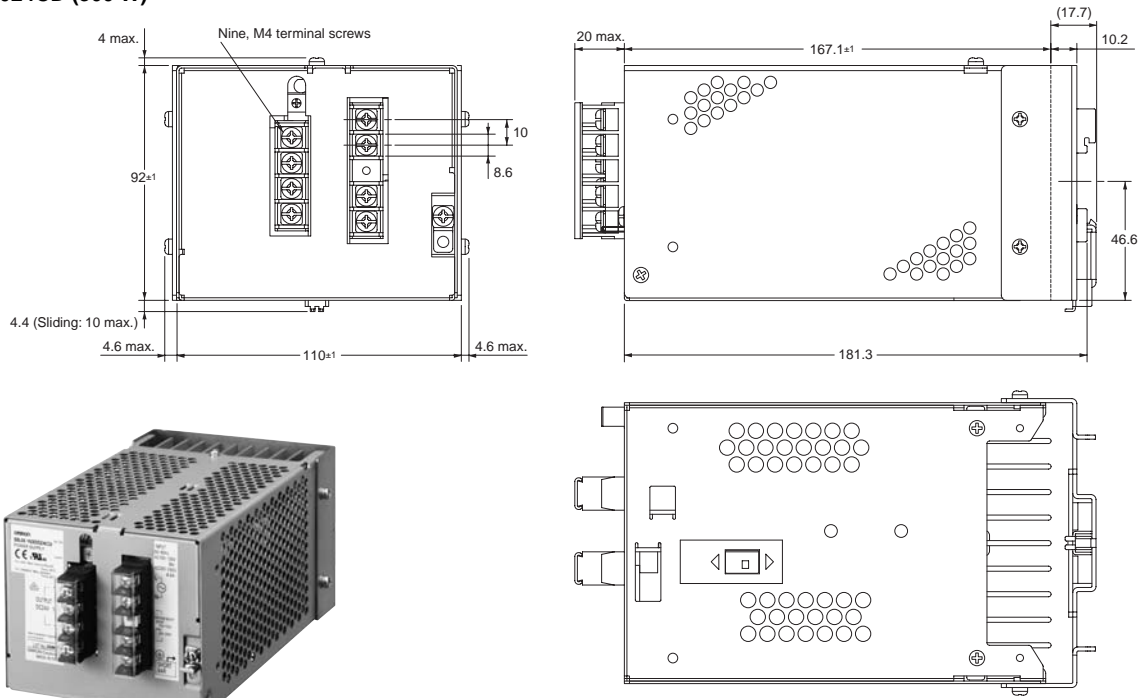

Note: Use a metal DIN Rail when mounting a 300-W model to a DIN Rail.

DIN Rail (Order Separately)

Mounting Rail
(Material: Aluminum)

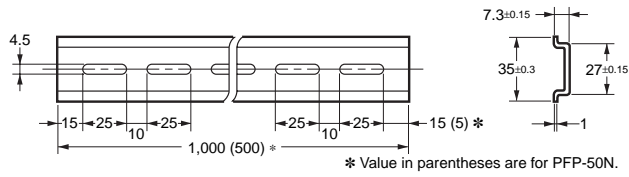
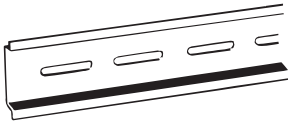

| Model |
|----------|
| PFP-100N |
| PFP-50N |

Mounting Rail
(Material: Aluminum)

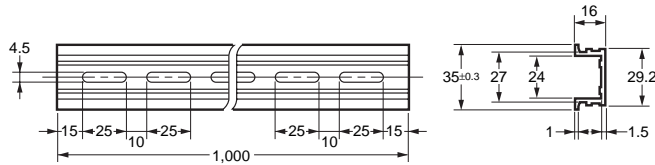

| Model |
|-----------|
| PFP-100N2 |

End Plate

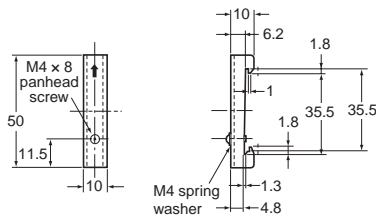
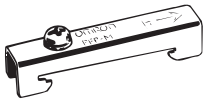

| Model |
|-------|
| PFP-M |

- Note: 1. If there is a possibility that the Unit will be subject to vibration or shock, use a steel DIN Rail. Otherwise, metallic filings may result from aluminum abrasion.
 2. If the Unit may be subjected to sliding to either side, attach an End Plate (model PFP-M) on each side of the Unit.

S8JX

Safety Precautions

Refer to *Safety Precautions for All Power Supplies*.

CAUTION

Minor electric shock, fire, or Product failure may occasionally occur. Do not disassemble, modify, or repair the Product to touch the interior of the Product.



Minor burns may occasionally occur. Do not touch the Product while power is being supplied or immediately after power is turned OFF.



Fire may occasionally occur. Tighten terminal screws to the specified torque of 1.13 N·m. For the 5-V output terminal, tighten the terminal screw to 1.56 N·m.



Minor injury due to electric shock may occasionally occur. Do not touch the terminals while power is being supplied. Always close the terminal cover after wiring.



Minor electric shock, fire, or Product failure may occasionally occur. Do not allow any pieces of metal or conductors or any clippings or cuttings resulting from installation work to enter the Product.



Precautions for Safe Use

Mounting

- Take adequate measures to ensure proper heat dissipation to increase the long-term reliability of the Product.
- Be sure to allow convection in the atmosphere around devices when mounting. Do not use in locations where the ambient temperature exceeds the range of the derating curve. (except 600 W)
- The S8JX-□60024□ is designed to radiate heat by means of forced air-flow. Do not cover the air holes (provided at fan mounted side and the opposite side) to have enough air-cooling.
- The screws must not protrude beyond the following values inside the Power Supply when screw holes provided on the chassis are used.
15 W, 35 W, 50 W, 100 W, or 150 W: 4 mm min.
300 W or 600 W: 8 mm min.
Mounting screw tightening torque (recommended value) : 0.54 N·m.
- Rear mounting is possible using provided mounting bracket.
- When cutting out holes for mounting, make sure that cuttings do not enter the interior of the Products.
- Improper mounting will interfere with heat dissipation and may occasionally result in deterioration or damage of internal parts. Use the standard mounting method only.
- The internal parts may occasionally deteriorate and be broken due to adverse heat radiation. Do not loosen the screw on the side face of the main body.
- When mounting two or more Power Supplies side-by-side, allow at least 20 mm spacing between them.
- Provide a space of at least 20 mm back and forth when mounting 300-W and 600-W models as well.
- Use the metal plate as the mounting panel.
- Minor fire may occasionally occur. Set the input voltage switch to the input voltage that is to be used (150-W, 5-V models only).

15-/35-/50-/100-/150-W Models

Standard Mounting
(Front-mounting and DIN Rail-mounting)

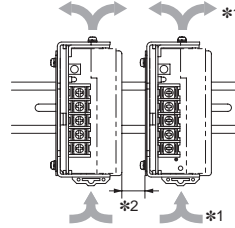

Standard Mounting
(Bottom-mounting)

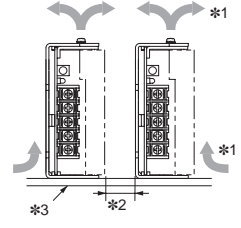

Standard Mounting
(Horizontal Mounting)

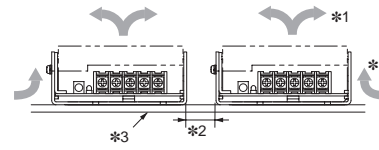

300-W Model

Standard Mounting
(Front-mounting and DIN Rail-mounting)

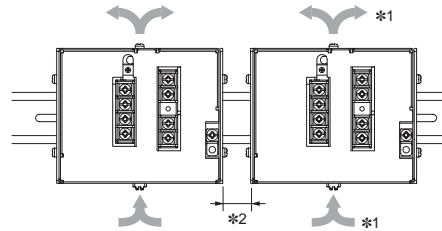

Standard Mounting
(Bottom-mounting)

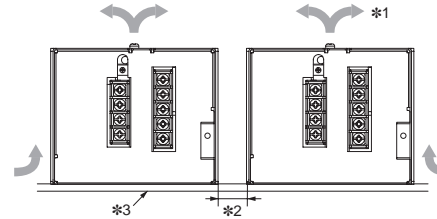

600-W Model

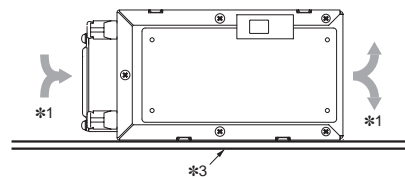

- *1. Convection of air
- *2. 20 mm max.
- *3. Use a metal plate as the mounting surface.

Wiring

- Connect the ground completely. A protective earthing terminal stipulated in safety standards is used. Electric shock or malfunction may occur if the ground is not connected completely.
- Minor fire may possibly occur. Ensure that input and output terminals are wired correctly.
- Do not apply more than 75 N force to the terminal block when tightening it.
- Be sure to remove the sheet covering the Product for machining before power-ON so that it does not interfere with heat dissipation.
- Use the following material for the wires to be connected to the S8JX to prevent smoking or ignition caused by abnormal loads.

Recommended Wire Type

| | |
|--|--|
| 15 W, 35 W | AWG12 to AWG20 (a cross section of 0.517 to 3.309 mm ²) UL-certified temperature of at least 75°C |
| 50W, 100W, 150 W (except for 5 V) | AWG12 to AWG16 (a cross section of 1.309 to 3.309 mm ²) UL-certified temperature of at least 60°C or 60/75°C |
| 150 W at 5 V | Input side AWG12 to AWG16 (a cross-section of 1.309 to 3.309 mm ²) UL-certified temperature of at least 60°C or 60/75°C |
| | Output side AWG8 to AWG14 (a cross-section of 2.081 to 8.368 mm ²) UL-certified temperature of at least 60°C or 60/75°C |
| 300 W, 600 W | AWG12 to AWG20 (a cross section of 0.517 to 3.309 mm ²) UL-certified temperature of at least 60°C or 60/75°C |

Installation Environment

- Do not use the Power Supply in locations subject to shocks or vibrations. In particular, install the Power Supply as far away as possible from contactors or other devices that are a vibration source.
- Install the Power Supply well away from any sources of strong, high-frequency noise and surge.

Ambient Operating and Storage Environments

- Store the Power Supply at a temperature of -25 to 65°C and a humidity of 25% to 90%.
- The Internal parts may occasionally deteriorate or be damaged. Do not use the Power Supply outside the derating range (i.e., the area shown by shading ① in the derating curve diagram on page 13.)
- Use the Power Supply at a humidity of 25% to 85%.
- Do not use the Power Supply in locations subject to direct sunlight.
- Do not use locations where liquids, foreign matter, or corrosive gases may enter the interior of the Product.

Overload Protection

- Internal parts may possibly deteriorate or be damaged if a short-circuited or overload state continues during operation.
- Internal parts may possibly deteriorate or be damaged if the Power Supply is used for applications with frequent inrush current or overloading at the load end. Do not use the Power Supply for such applications.

Charging a Battery

When connecting a battery at the load, connect an overcurrent limiting circuit and overvoltage protection circuit.

Output Voltage Adjuster (V.ADJ)

- The output voltage adjuster (V.ADJ) may possibly be damaged if it is turned with unnecessary force. Do not turn the adjuster with excessive force.
- After completing output voltage adjustment, be sure that the output capacity or output current does not exceed the rated output capacity or rated output current.

DIN Rail-mounting

To mount the Power Supply to a DIN Rail, pull down the rail stopper until you hear it clicks open, hook portion (A) of the Power Supply onto the DIN Rail, press the Power Supply in direction (B), and then push up the rail stopper to lock the Power Supply in place.

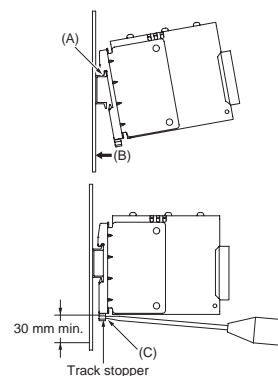

To dismantle the Power Supply, pull down portion (C) with a flat-blade screwdriver and pull out the Power Supply.

Series Operation

Two power supplies can be connected in series. The (±) voltage output can be accomplished with two Power Supplies.

Series Operation Correct

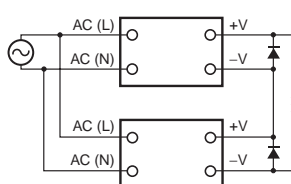

Output Voltage (±) Correct

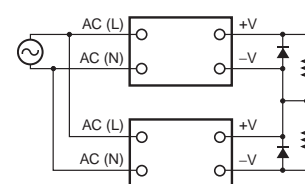

Note: 1. If the load is short-circuited, a reverse voltage will be generated inside the Power Supply. If this occurs the Power Supply may possibly deteriorate or be damaged. Always connect a diode as shown in the figure. Select a diode having the following ratings.

| Type | Schottky Barrier diode |
|---|---|
| Dielectric strength (V _{RRM}) | Twice the rated output voltage or above |
| Forward current (I _F) | Twice the rated output current or above |

2. Although Products having different specifications can be connected in series, the current flowing through the load must not exceed the smaller rated output current.

Parallel Operation

15-/35-/50-/100-/150-W Models

The Product is not designed for parallel operation.

Parallel Operation Incorrect

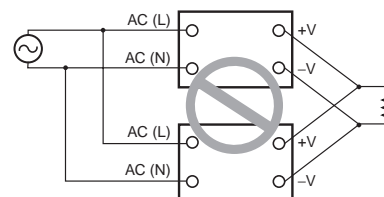

300-/600-W Models

Parallel operation is possible under 80% of the rated value.

- To operate in parallel, set the switch to the "PARALLEL" side.
- The length and thickness of each wire connected to the load must be the same so that there is no difference in voltage drop value between the load and the output terminals of each Power Supply.
- It is desirable to set the same value on the voltage adjuster of each Power Supply.

Parallel Operation Correct

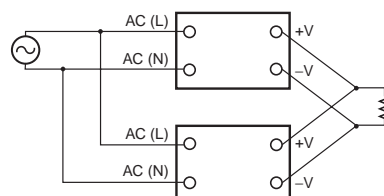

In Case There Is No Output Voltage

The possible cause for no output voltage may be that the overcurrent or overvoltage protection has operated. The internal protection may operate if a large amount of surge voltage such as a lightening surge occurs while turning ON the Power Supply. In case there is no output voltage, please check the following points before contacting us:

- Checking overcurrent protected status:
Check whether the load is in overcurrent status or is short-circuited. Remove wires to load when checking.
- Checking overvoltage or internal protection:
Turn the power supply OFF once, and leave it OFF for at least 7 minutes. Then turn it ON again to see if this clears the condition.

Switching the AC Input Voltage between 100 and 200 VAC

150-W, 5-V Models

The input voltage can be switched between 100 V and 200 V by using the input voltage switch. Make the setting shown in the following figure for the voltage that will be used. (The input voltage is factory-set to 200 V.)

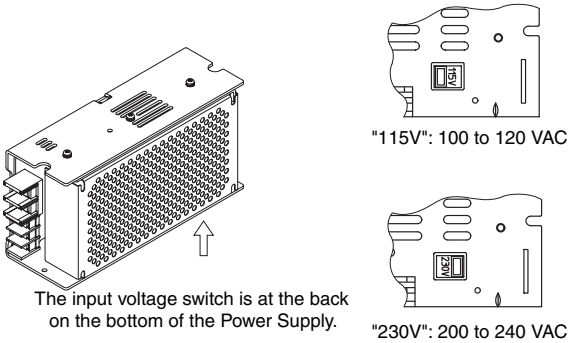

300-/600-W Models

The input voltage can be switched between 100 and 200 V by shorting or opening the input voltage selection terminals. Set the required voltage as shown below. (The voltage is factory-set to 200 V.)

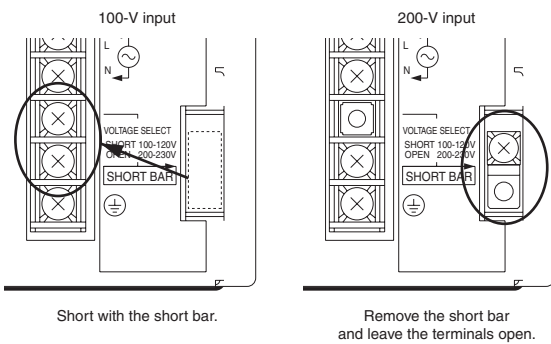

Note: A 300-W model is shown above.

Fan Replacement

600-W Model

The service life of the fan is approximately 50,000 hours (at 25°C). The service life varies, however, depending on the ambient temperature or other surrounding environmental conditions such as dust. As a preventive maintenance measure, replace the fan within approx. two years if it is used at an ambient temperature of 40°C. Fans (S82Y-JXFAN) are available as replacements.

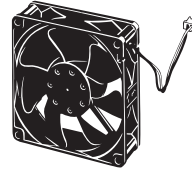

Fan Set:

Fan (above), instruction sheet, and packing case

Replace the fan as shown in the following illustration.

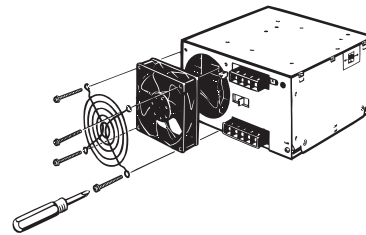

ALL DIMENSIONS SHOWN ARE IN MILLIMETERS.

To convert millimeters into inches, multiply by 0.03937. To convert grams into ounces, multiply by 0.03527.

In the interest of product improvement, specifications are subject to change without notice.

Read and Understand this Catalog

Please read and understand this catalog before purchasing the product. Please consult your OMRON representative if you have any questions or comments.

Warranty and Limitations of Liability

WARRANTY

OMRON's exclusive warranty is that the products are free from defects in materials and workmanship for a period of one year (or other period if specified) from date of sale by OMRON.

OMRON MAKES NO WARRANTY OR REPRESENTATION, EXPRESS OR IMPLIED, REGARDING NON-INFRINGEMENT, MERCHANTABILITY, OR FITNESS FOR PARTICULAR PURPOSE OF THE PRODUCTS. ANY BUYER OR USER ACKNOWLEDGES THAT THE BUYER OR USER ALONE HAS DETERMINED THAT THE PRODUCTS WILL SUITABLY MEET THE REQUIREMENTS OF THEIR INTENDED USE. OMRON DISCLAIMS ALL OTHER WARRANTIES, EXPRESS OR IMPLIED.

LIMITATIONS OF LIABILITY

OMRON SHALL NOT BE RESPONSIBLE FOR SPECIAL, INDIRECT, OR CONSEQUENTIAL DAMAGES, LOSS OF PROFITS, OR COMMERCIAL LOSS IN ANY WAY CONNECTED WITH THE PRODUCTS, WHETHER SUCH CLAIM IS BASED ON CONTRACT, WARRANTY, NEGLIGENCE, OR STRICT LIABILITY.

In no event shall the responsibility of OMRON for any act exceed the individual price of the product on which liability is asserted.

IN NO EVENT SHALL OMRON BE RESPONSIBLE FOR WARRANTY, REPAIR, OR OTHER CLAIMS REGARDING THE PRODUCTS UNLESS OMRON'S ANALYSIS CONFIRMS THAT THE PRODUCTS WERE PROPERLY HANDLED, STORED, INSTALLED, AND MAINTAINED AND NOT SUBJECT TO CONTAMINATION, ABUSE, MISUSE, OR INAPPROPRIATE MODIFICATION OR REPAIR.

Application Considerations

SUITABILITY FOR USE

OMRON shall not be responsible for conformity with any standards, codes, or regulations that apply to the combination of products in the customer's application or use of the products.

Take all necessary steps to determine the suitability of the product for the systems, machines, and equipment with which it will be used.

Know and observe all prohibitions of use applicable to this product.

NEVER USE THE PRODUCTS FOR AN APPLICATION INVOLVING SERIOUS RISK TO LIFE OR PROPERTY WITHOUT ENSURING THAT THE SYSTEM AS A WHOLE HAS BEEN DESIGNED TO ADDRESS THE RISKS, AND THAT THE OMRON PRODUCTS ARE PROPERLY RATED AND INSTALLED FOR THE INTENDED USE WITHIN THE OVERALL EQUIPMENT OR SYSTEM.

PROGRAMMABLE PRODUCTS

OMRON shall not be responsible for the user's programming of a programmable product, or any consequence thereof.

Disclaimers

CHANGE IN SPECIFICATIONS

Product specifications and accessories may be changed at any time based on improvements and other reasons.

It is our practice to change model numbers when published ratings or features are changed, or when significant construction changes are made. However, some specifications of the products may be changed without any notice. When in doubt, special model numbers may be assigned to fix or establish key specifications for your application on your request. Please consult with your OMRON representative at any time to confirm actual specifications of purchased products.

DIMENSIONS AND WEIGHTS

Dimensions and weights are nominal and are not to be used for manufacturing purposes, even when tolerances are shown.

PERFORMANCE DATA

Performance data given in this catalog is provided as a guide for the user in determining suitability and does not constitute a warranty. It may represent the result of OMRON's test conditions, and the users must correlate it to actual application requirements. Actual performance is subject to the OMRON Warranty and Limitations of Liability.

OMRON Corporation Industrial Automation Company

Tokyo, JAPAN

Contact: www.ia.omron.com

Regional Headquarters

OMRON EUROPE B.V.

Wegalaan 67-69-2132 JD Hoofddorp
The Netherlands

Tel: (31)2356-81-300/Fax: (31)2356-81-388

OMRON ELECTRONICS LLC

One Commerce Drive Schaumburg,
IL 60173-5302 U.S.A.

Tel: (1) 847-843-7900/Fax: (1) 847-843-7787

OMRON ASIA PACIFIC PTE. LTD.

No. 438A Alexandra Road # 05-05/08 (Lobby 2),
Alexandra Technopark,
Singapore 119967

Tel: (65) 6835-3011/Fax: (65) 6835-2711

OMRON (CHINA) CO., LTD.

Room 2211, Bank of China Tower,
200 Yin Cheng Zhong Road,
PuDong New Area, Shanghai, 200120, China

Tel: (86) 21-5037-2222/Fax: (86) 21-5037-2200

Authorized Distributor:

© OMRON Corporation 2009 All Rights Reserved.
In the interest of product improvement,
specifications are subject to change without notice.

CSM_9_1_0211

Cat. No. T041-E1-04

Printed in Japan

1110