

THYRISTOR	200A Avg 800 Volts	PGH2008AM
-----------	--------------------	-----------

回路図 CIRCUIT

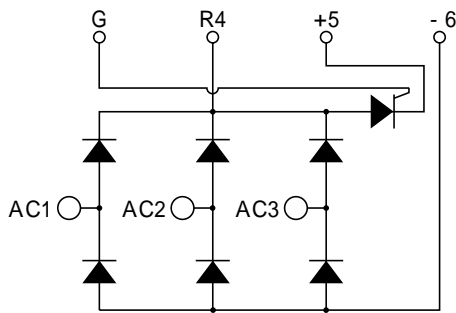

外形寸法図 OUTLINE DRAWING

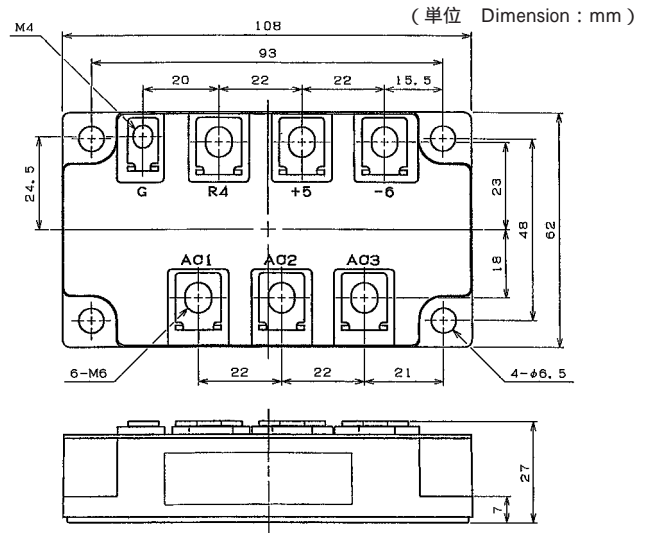

総合定格・特性 Part of Diode Bridge & Thyristor

最大定格 Maximum Ratings

項目 Parameter	記号 Symbol	条件 Conditions	定格値 Max. Rated Value	単位 Unit	
平均出力電流 Average Rectified Output Current	$I_{O(AV)}$	$T_c = 93$ (電圧印加なし) Non-Bias	200	A	
		$T_c = 68$ (電圧印加あり) Bias	200	A	
動作接合温度範囲 Operating Junction Temperature Range	T_{jw}	125 ~ 150 はサイリスタ部に順・逆電圧印加しない事 $T_j > 125$, Can not be Biased for Thyristor.	- 40 ~ + 150		
保存温度範囲 Storage Temperature Range	T_{stg}		- 40 ~ + 125		
絶縁耐圧 Isolation Voltage	V_{iso}	端子 - ベース間, AC 1 分間 Terminal to Base, AC 1 min.	2000	V	
締付トルク Mounting Torque	F	ベース部 Mounting	M6	2.5 ~ 3.5	N・m
		主端子部 Terminal	M6	2.5 ~ 3.5	N・m
		ゲート端子部 Gate Terminal	M4	1.2 ~ 1.6	N・m

熱特性 Thermal Characteristics

項目 Parameter	記号 Symbol	条件 Conditions	特性値 (最大) Maximum Value	単位 Unit
接触熱抵抗 Thermal Resistance	$R_{th(c-f)}$	ケース・フィン間(トータル), サーマルコンパウンド塗布 Case to Fin, Total, Greased	0.06	/W

質量 Approximate Weight...約530g

ダイオードブリッジ部 (6素子) Part of Diode Bridge (6 dies)

最大定格 Maximum Ratings

項目 Parameter	記号 Symbol	耐压クラス Grade	単位 Unit
		PGH2008AM	
くり返しピーク逆電圧 *1 Repetitive Peak Reverse Voltage	V_{RRM}	800	V
非くり返しピーク逆電圧 *1 Non Repetitive Peak Reverse Voltage	V_{RSM}	900	V

項目 Parameter	記号 Symbol	条件 Conditions	定格値 Max. Rated Value	単位 Unit
サージ順電流 *1 Surge Forward Current	I_{FSM}	50Hz正弦半波, 1 サイクル, 非くり返し Half Sine Wave, 1Pulse, Non-Repetitive	1800	A
電流二乗時間積 *1 I Squared t	I^2t	2 ~ 10ms	16200	A ² s
許容周波数 Allowable Operating Frequency	f		400	Hz

*1: 1 アーム当りの値 Value Per 1 Arm.

電気的特性 Electrical Characteristics

項目 Parameter	記号 Symbol	条件 Conditions	特性値(最大) Maximum Value	単位 Unit
ピーク逆電流 Peak Reverse Current	I_{RM}	$T_j=125$, $V_{RM}=V_{RRM}$	20	mA
ピーク順電圧 Peak Forward Voltage	V_{FM}	$T_j=25$, $I_{FM}=200A$	1.20	V
熱抵抗 Thermal Resistance	$R_{th(j-c)}$	接合部 - ケース間 (トータル) Junction to Case, Total	0.10	/W

*1 : 1 アーム当りの値 Value Per 1 Arm.

サイリスタ部 (1素子) Part of Thyristor (1die)

最大定格 Maximum Ratings

項目 Parameter	記号 Symbol	耐圧クラス Grade		単位 Unit
		PGH2008AM		
くり返しピークオフ電圧 Repetitive Peak Off-State Voltage	V_{DRM}	800		V
非くり返しピークオフ電圧 Non Repetitive Peak Off-State Voltage	V_{DSM}	900		V
くり返しピーク逆電圧 Repetitive Peak Reverse Voltage	V_{RRM}	800		V
非くり返しピーク逆電圧 Non Repetitive Peak Reverse Voltage	V_{RSM}	900		V

項目 Parameter	記号 Symbol	条件 Conditions	定格値 Max. Rated Value	単位 Unit
サージオン電流 Surge On-State Current	I_{TSM}	50Hz正弦半波, 1 サイクル, 非くり返し Half Sine Wave, 1Pulse, Non-Repetitive	3200	A
電流二乗時間積 I Squared t	I^2t	2 ~ 10ms	51200	A^2s
臨界オン電流上昇率 Critical Rate of Rise of Turned-On Current	di/dt	$V_D=2/3V_{DRM}$, $I_{TM}=2 \cdot I_o$, $T_j=125$ $I_G=300mA$, $di_G/dt=0.2A/\mu s$	100	A/ μs
ピークゲート電力損失 Peak Gate Power	P_{GM}		5	W
平均ゲート電力損失 Average Gate Power	$P_{G(AV)}$		1	W
ピークゲート電流 Peak Gate Current	I_{GM}		2	A
ピークゲート電圧 Peak Gate Voltage	V_{GM}		10	V
ピークゲート逆電圧 Peak Gate Reverse Voltage	V_{RGM}		5	V

電気的特性 Electrical Characteristics

項目 Parameter	記号 Symbol	条件 Conditions	特性値(最大) Maximum Value			単位 Unit
			最小 Min.	標準 Typ.	最大 Max.	
ピークオフ電流 Peak Off-State Current	I_{DM}	$T_j=125$, $V_{DM}=V_{DRM}$			30	mA
ピークオン電圧 Peak On-State Voltage	V_{TM}	$T_j=25$, $I_{TM}=200A$			1.23	V
トリガゲート電流 Gate Current to Trigger	I_{GT}	$V_D=6V$, $I_T=1A$	$T_j=-40$		300	mA
			$T_j=25$		150	mA
			$T_j=125$		80	mA
トリガゲート電圧 Gate Voltage to Trigger	V_{GT}	$V_D=6V$, $I_T=1A$	$T_j=-40$		5.0	V
			$T_j=25$		3.0	V
			$T_j=125$		2.0	V
非トリガゲート電圧 Gate Non-Trigger Voltage	V_{GD}	$T_j=125$, $V_D=2/3V_{DRM}$	0.25			V
臨界オフ電圧上昇率 Critical Rate of Rise of Off-State Voltage	dv/dt	$T_j=125$, $V_D=2/3V_{DRM}$	500			V/ μs
ターンオフ時間 Turn-Off Time	t_q	$T_j=125$, $I_{TM}=I_o$, $V_D=2/3V_{DRM}$ $dv/dt=20V/\mu s$, $V_R=100V$, $-di/dt=20A/\mu s$		150		μs
ターンオン時間 Turn-On Time	t_{gt}			6		μs
遅れ時間 Delay Time	t_d	$T_j=25$, $V_D=2/3V_{DRM}$, $I_{TM}=3 \cdot I_o$ $I_G=300mA$, $di_G/dt=0.2A/\mu s$		2		μs
立上がり時間 Rise Time	t_r			4		μs
ラッチング電流 Latching Current	I_L	$T_j=25$		150		mA
保持電流 Holding Current	I_H	$T_j=25$		100		mA
熱抵抗 Thermal Resistance	$R_{th(j-c)}$	接合部 - ケース間 Junction to Case			0.25	/W

順電圧特性
FORWARD CURRENT VS. VOLTAGE

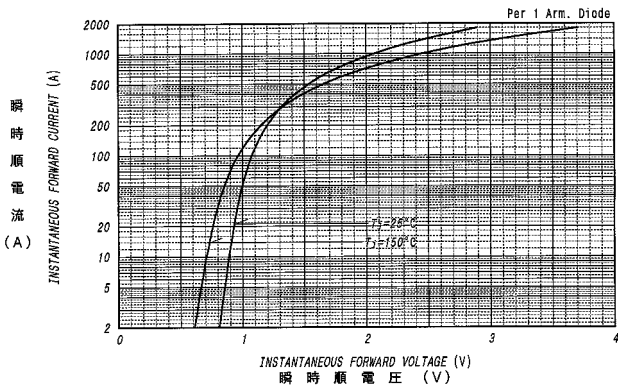

平均順電力損失特性
AVERAGE FORWARD POWER DISSIPATION

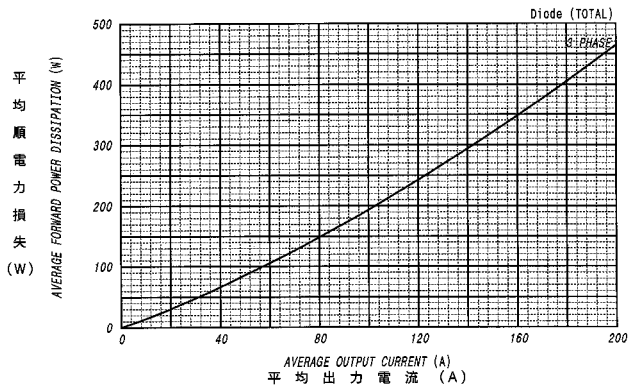

オン電圧特性
ON-STATE CURRENT VS. VOLTAGE

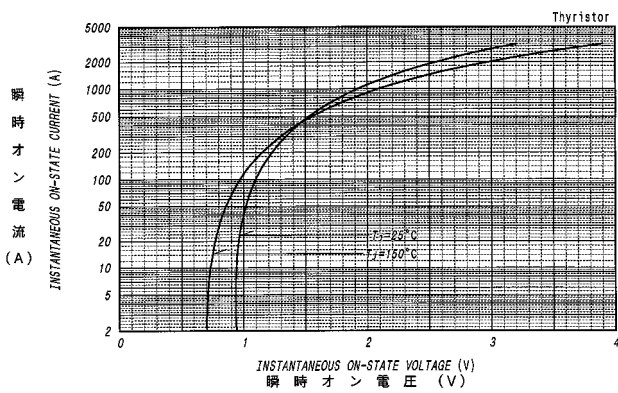

平均オン電力損失特性
AVERAGE ON-STATE POWER DISSIPATION

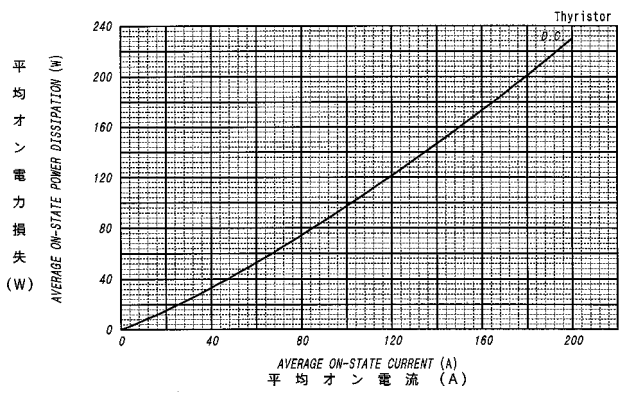

平均出力電流 - ケース温度定格
AVERAGE OUTPUT CURRENT VS. CASE TEMPERATURE

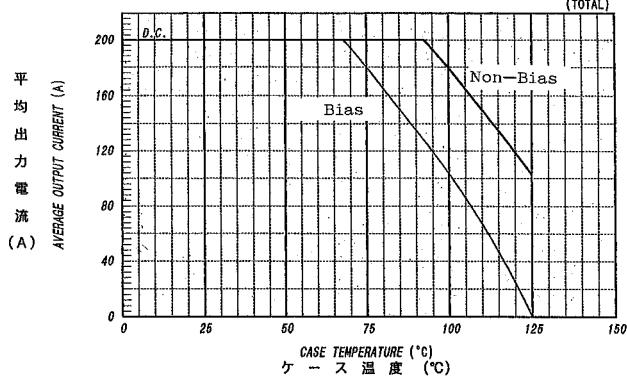

サージ電流定格
SURGE CURRENT RATINGS

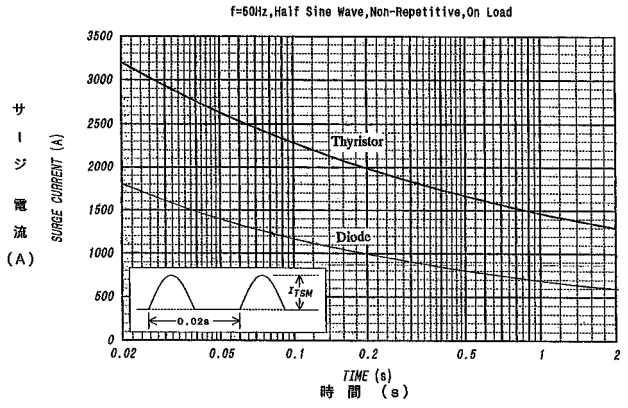

ゲート特性
GATE CHARACTERISTICS

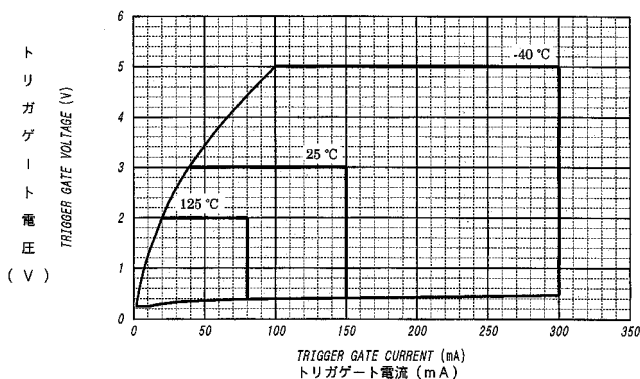

ゲート定格
GATE RATINGS

