



## Bi-Directional N-Channel 20-V (D-S) MOSFET

PRODUCT SUMMARY		
$V_{S1S2}$ (V)	$r_{S1S2(on)}$ ( $\Omega$ )	$I_{S1S2}$ (A)
20	0.024 @ $V_{GS} = 4.5$ V	7
	0.026 @ $V_{GS} = 3.7$ V	6.8
	0.034 @ $V_{GS} = 2.5$ V	5.0
	0.040 @ $V_{GS} = 1.8$ V	5.5

### FEATURES

- TrenchFET® Power MOSFET
- Ultra-Low  $r_{SS(on)}$
- ESD Protected: 4000 V
- New MICRO FOOT™ Chipscale Packaging Reduces Footprint Area Profile (0.62 mm) and On-Resistance Per Footprint Area

### APPLICATIONS

- Battery Protection Circuit
  - 1-2 Cell Li+/LiP Battery Pack for Portable Devices

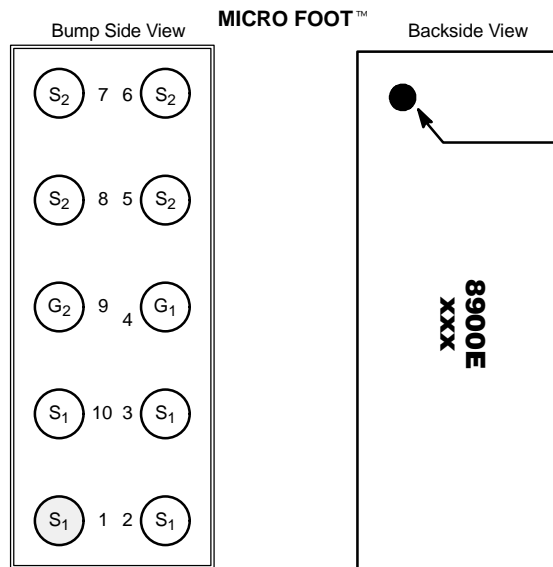

Device Marking:  
8900E = P/N Code  
xxx = Date/Lot Traceability Code

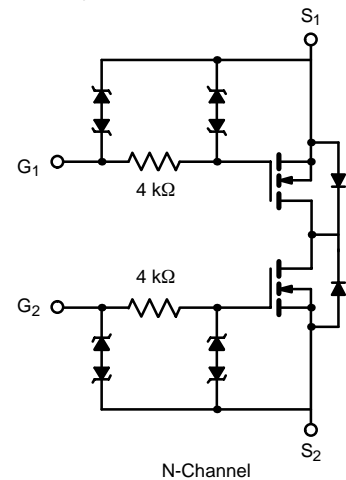

ABSOLUTE MAXIMUM RATINGS ( $T_A = 25^\circ\text{C}$ UNLESS OTHERWISE NOTED)					
Parameter	Symbol	5 secs	Steady State	Unit	
Source1—Source2 Voltage	$V_{S1S2}$	20		V	
Gate-Source Voltage	$V_{GS}$	$\pm 12$			
Continuous Source1—Source2 Current ( $T_J = 150^\circ\text{C}$ ) <sup>a</sup>	$I_{S1S2}$	$T_A = 25^\circ\text{C}$	7	5.4	A
		$T_A = 85^\circ\text{C}$	5.1	3.9	
Pulsed Source1—Source2 Current	$I_{SM}$	10			
Maximum Power Dissipation <sup>a</sup>	$P_D$	$T_A = 25^\circ\text{C}$	1.8	1	W
		$T_A = 85^\circ\text{C}$	0.9	0.5	
Operating Junction and Storage Temperature Range	$T_J, T_{stg}$	-55 to 150		$^\circ\text{C}$	
Package Reflow Conditions <sup>c</sup>	VPR	215			
	IR/Convection	220			

THERMAL RESISTANCE RATINGS					
Parameter	Symbol	Typical	Maximum	Unit	
Maximum Junction-to-Ambient <sup>a</sup>	$R_{thJA}$	$t \leq 5$ sec	55	70	$^\circ\text{C/W}$
		Steady State	95	120	
Maximum Junction-to-Foot <sup>b</sup>	$R_{thJF}$	12	15		

- Notes
- Surface Mounted on 1" x 1" FR4 Board.
  - The Foot is defined as the top surface of the package.
  - Refer to IPC/JEDEC (J-STD-020A), no manual or hand soldering.

**SPECIFICATIONS ( $T_J = 25^\circ\text{C}$  UNLESS OTHERWISE NOTED)**

Parameter	Symbol	Test Condition	Min	Typ	Max	Unit
<b>Static</b>						
Gate Threshold Voltage	$V_{GS(th)}$	$V_{SS} = V_{GS}, I_D = 1.1\text{ mA}$	0.45		1.0	V
Gate-Body Leakage	$I_{GSS}$	$V_{SS} = 0\text{ V}, V_{GS} = \pm 4.5\text{ V}$			$\pm 4$	$\mu\text{A}$
		$V_{SS} = 0\text{ V}, V_{GS} = \pm 12\text{ V}$			$\pm 10$	mA
Zero Gate Voltage Source Current	$I_{S1S2}$	$V_{SS} = 16\text{ V}, V_{GS} = 0\text{ V}$			1	$\mu\text{A}$
		$V_{SS} = 16\text{ V}, V_{GS} = 0\text{ V}, T_J = 85^\circ\text{C}$			5	
On-State Source Current <sup>a</sup>	$I_{S(on)}$	$V_{SS} = 5\text{ V}, V_{GS} = 4.5\text{ V}$	5			A
Source1—Source2 On-State Resistance <sup>a</sup>	$r_{S1S2(on)}$	$V_{GS} = 4.5\text{ V}, I_{SS} = 1\text{ A}$		0.020	0.024	$\Omega$
		$V_{GS} = 3.7\text{ V}, I_{SS} = 1\text{ A}$		0.022	0.026	
		$V_{GS} = 2.5\text{ V}, I_{SS} = 1\text{ A}$		0.026	0.034	
		$V_{GS} = 1.8\text{ V}, I_{SS} = 1\text{ A}$		0.032	0.040	
Forward Transconductance <sup>a</sup>	$g_{fs}$	$V_{SS} = 10\text{ V}, I_{SS} = 1\text{ A}$		31		S
<b>Dynamic<sup>b</sup></b>						
Turn-On Delay Time	$t_{d(on)}$	$V_{SS} = 10\text{ V}, R_L = 10\ \Omega$ $I_{SS} \cong 1\text{ A}, V_{GEN} = 4.5\text{ V}, R_G = 6\ \Omega$		3	5	$\mu\text{S}$
Rise Time	$t_r$			4.5	7	
Turn-Off Delay Time	$t_{d(off)}$			55	85	
Fall Time	$t_f$			15	25	

## Notes

- a. Pulse test; pulse width  $\leq 300\ \mu\text{s}$ , duty cycle  $\leq 2\%$ .  
b. Guaranteed by design, not subject to production testing.

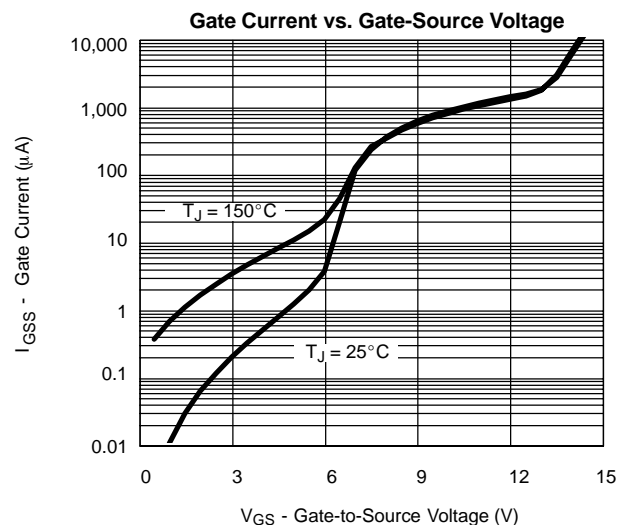
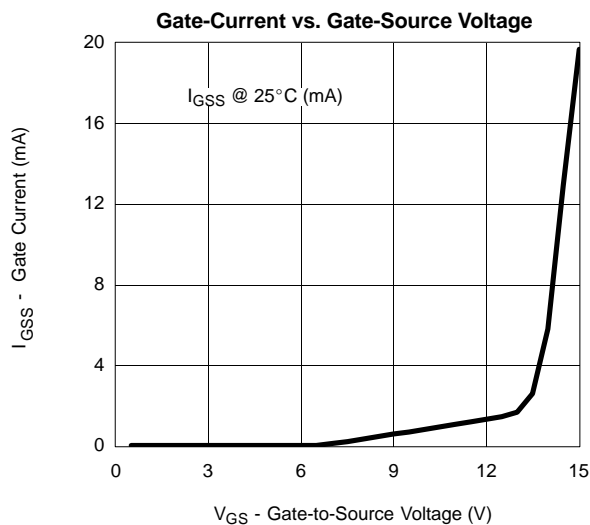
**TYPICAL CHARACTERISTICS ( $25^\circ\text{C}$  UNLESS NOTED)**



**TYPICAL CHARACTERISTICS (25 °C UNLESS NOTED)**

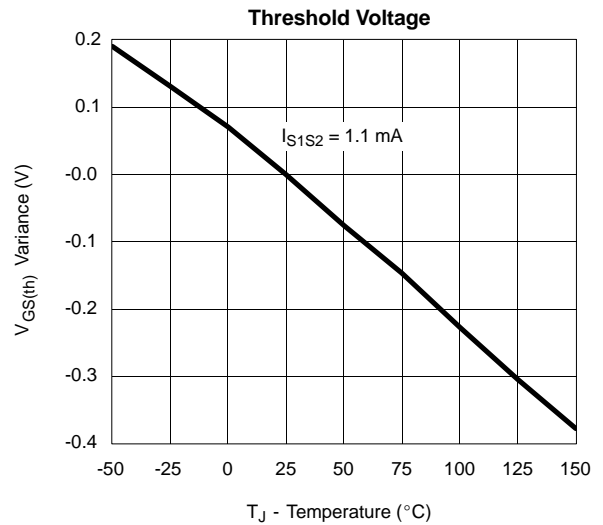
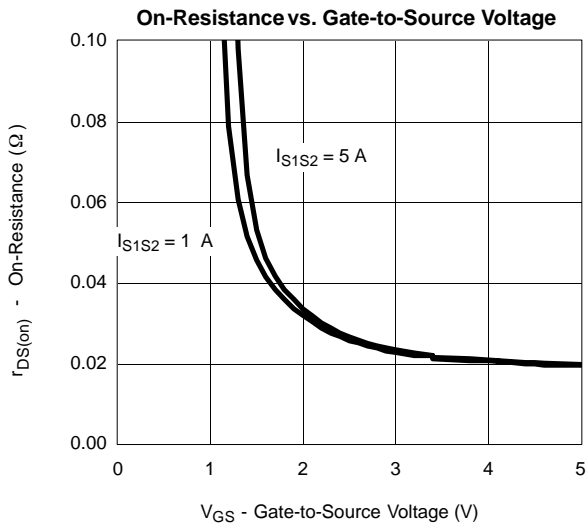
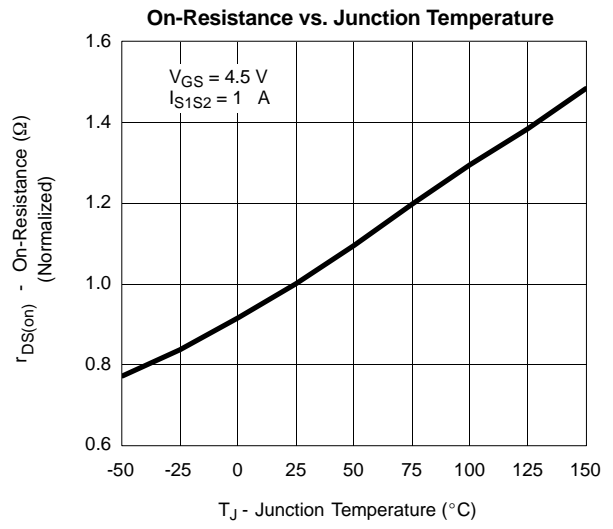
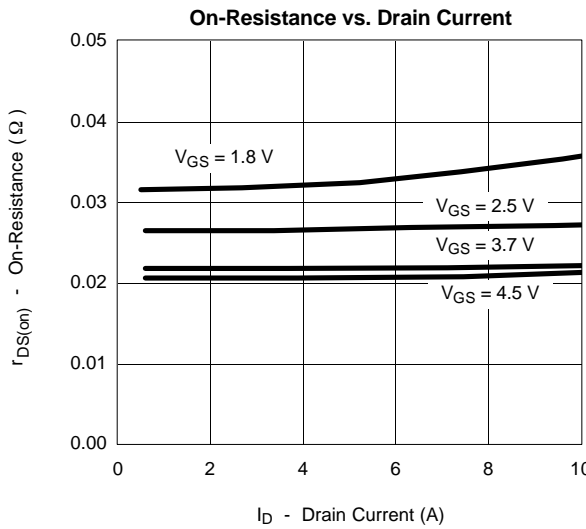
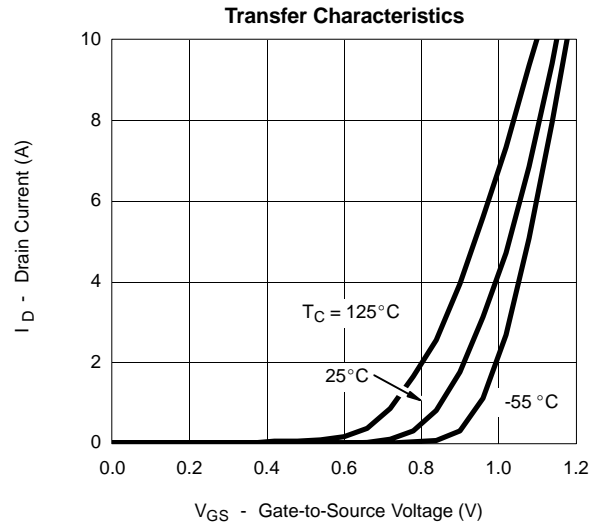
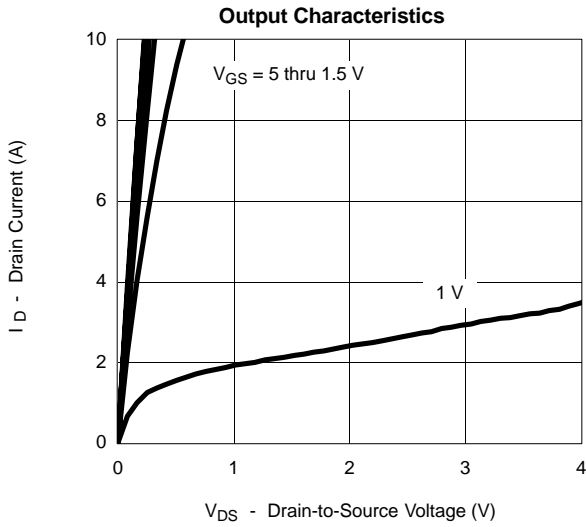

**TYPICAL CHARACTERISTICS (25°C UNLESS NOTED)**

Single Pulse Power, Junction-to-Ambient

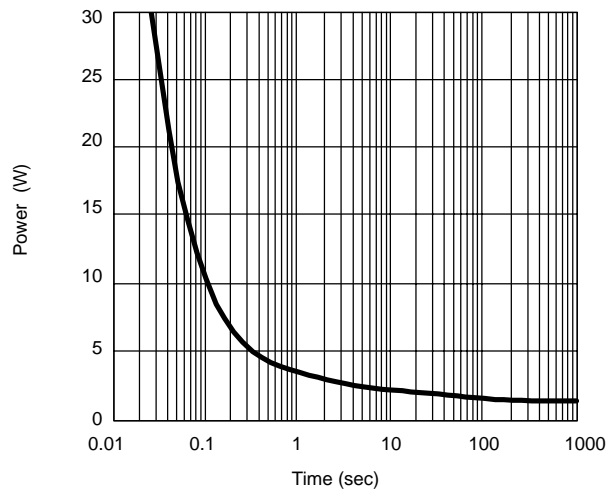

Normalized Thermal Transient Impedance, Junction-to-Ambient

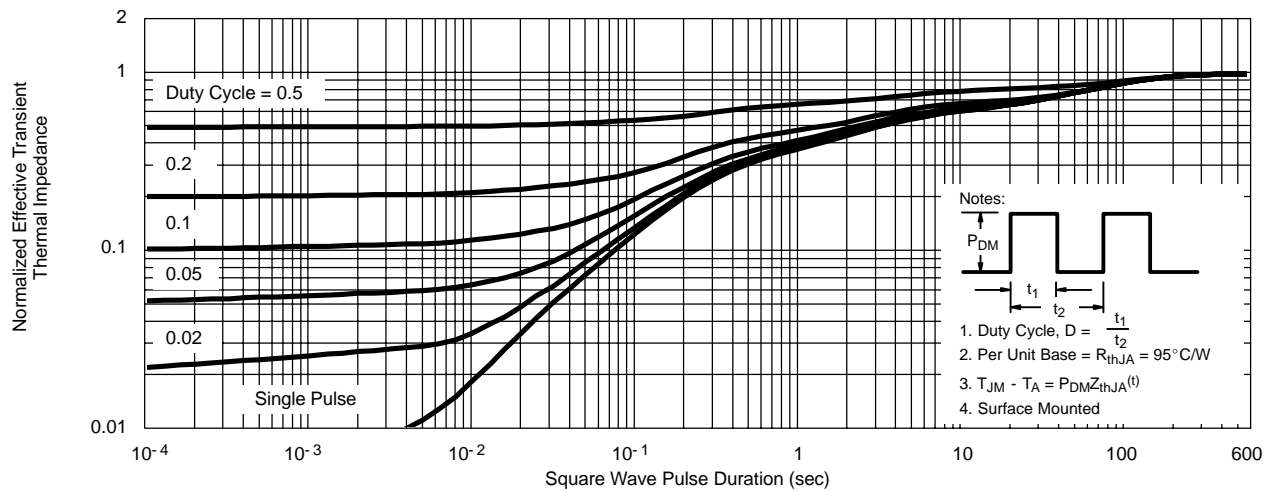

Normalized Thermal Transient Impedance, Junction-to-Foot

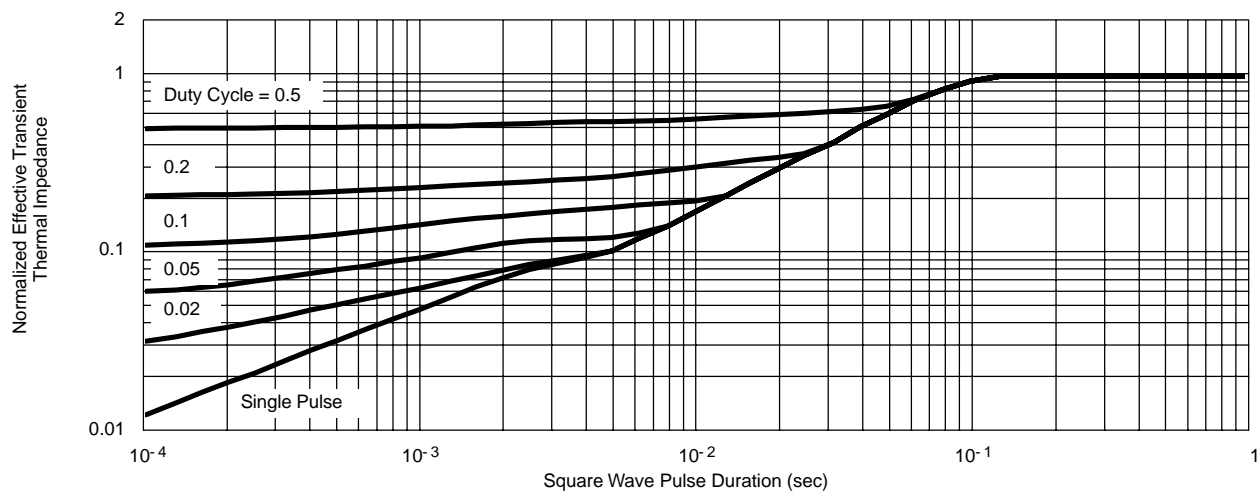

**PACKAGE OUTLINE**

**MICRO FOOT: 10-BUMP (2 X 5, 0.8-mm PITCH)**

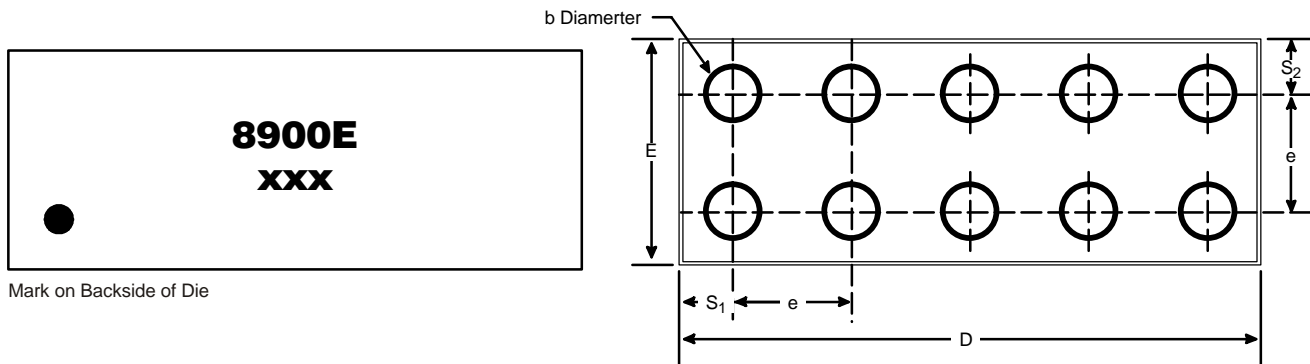
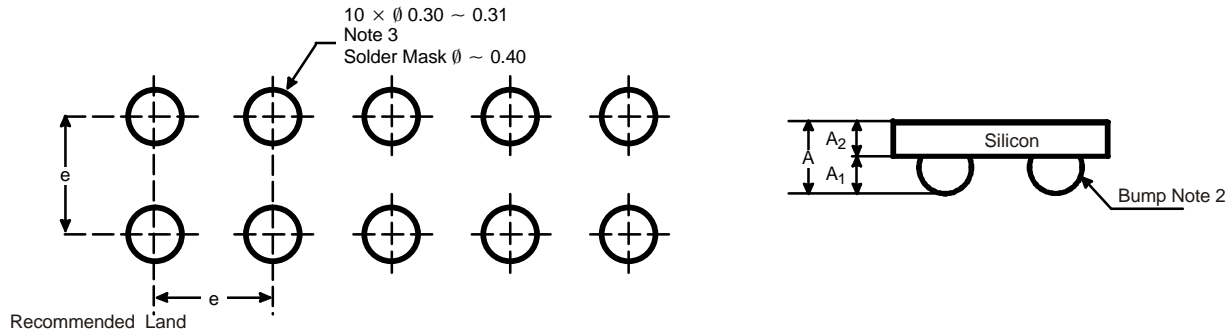

NOTES (Unless Otherwise Specified):

1. Laser mark on the silicon die back, coated with a thin metal.
2. Bumps are Eutectic solder 63/57 Sn/Pb.
3. Non-solder mask defined copper landing pad.

Dim	MILLIMETERS*		INCHES	
	Min	Max	Min	Max
A	0.600	0.650	0.0236	0.0256
A <sub>1</sub>	0.260	0.290	0.102	0.0114
A <sub>2</sub>	0.340	0.360	0.0134	0.0142
b	0.370	0.410	0.0146	0.0161
D	4.050	4.060	0.1594	0.1598
E	1.980	2.000	0.0780	0.0787
e	0.750	0.850	0.0295	0.0335
S <sub>1</sub>	0.430	0.450	0.0169	0.0177
S <sub>2</sub>	0.580	0.600	0.0228	0.0236

\* Use millimeters as the primary measurement.