

### General Description

The 9FGU0831 is a member of IDT's 1.5V Ultra-Low-Power PCIe clock family. The device has 8 output enables for clock management, 2 different spread spectrum levels in addition to spread off and 2 selectable SMBus addresses.

### Recommended Application

- 1.5V PCIe Gen1-2-3 Clock Generator

### Output Features

- 8 - 100MHz Low-Power (LP) HCSL DIF pairs
- 1 - 1.5V LVCMOS REF output w/Wake-On-LAN (WOL) support

### Key Specification

- DIF cycle-to-cycle jitter <50ps
- DIF output-to-output skew < 60ps
- DIF phase jitter is PCIe Gen1-2-3 compliant
- REF phase jitter is < 3.0ps RMS

### Features/Benefits

- LP-HCSL outputs; save 16 resistors compared to standard PCIe devices
- 50mW typical power consumption; reduced thermal concerns
- Outputs can optionally be supplied from any voltage between 1.05 and 1.5V; maximum power savings
- OE# pins; support DIF power management
- Programmable Slew rate for each output; allows tuning for various line length
- Programmable output amplitude; allows tuning for various application environments
- DIF outputs blocked until PLL is locked; clean system start-up
- Selectable 0%, -0.25% or -0.5% spread on DIF outputs; reduces EM
- External 25MHz crystal; supports tight ppm with 0 ppm synthesis error
- Configuration can be accomplished with strapping pins; SMBus interface not required for device control
- Selectable SMBus addresses; multiple devices can easily share an SMBus segment
- 3.3V tolerant SMBus interface works with legacy controllers
- Space saving 48-pin 6x6 mm VFQFPN; minimal board space

### Functional Block Diagram

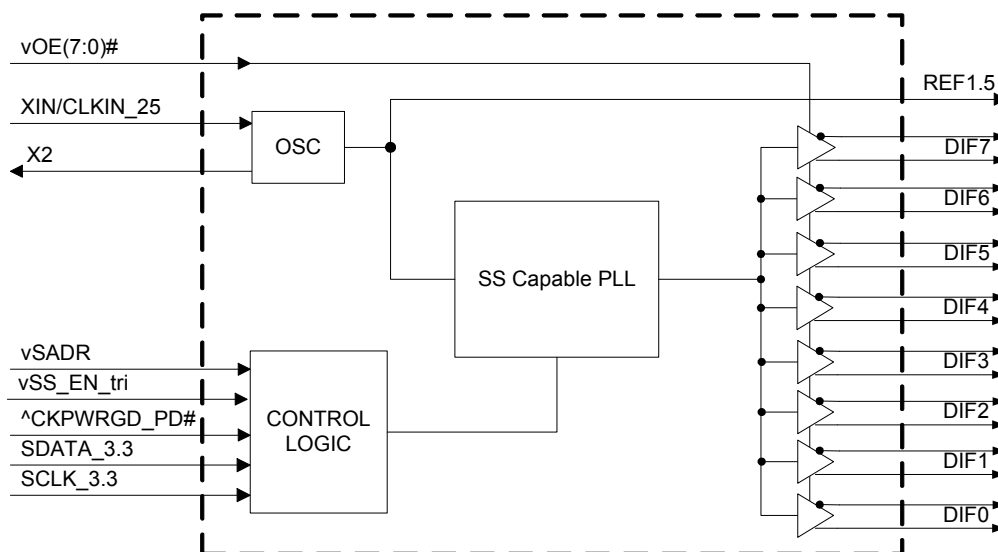

## Pin Configuration

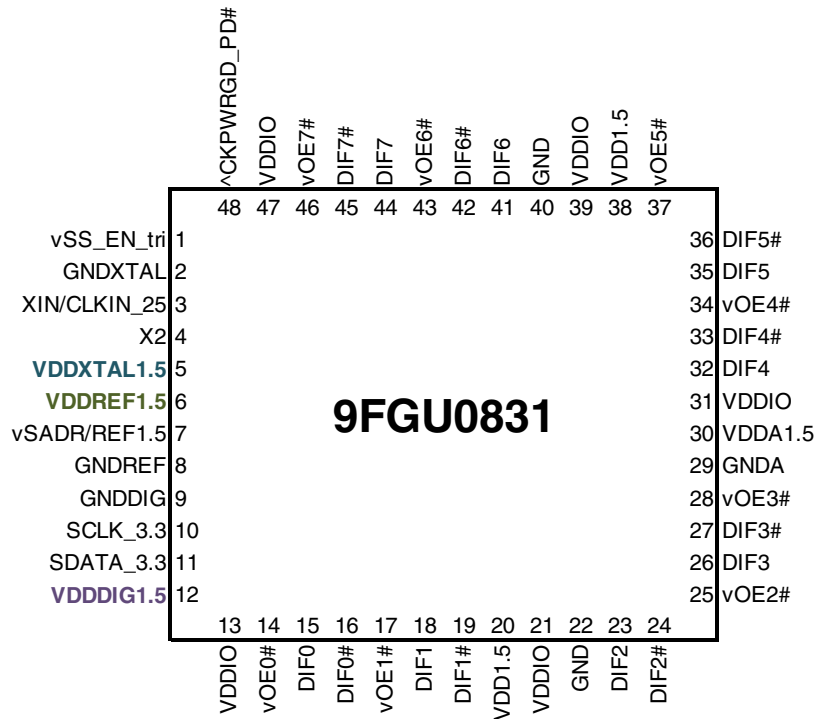

### 48-pin VFQFPN, 6x6 mm, 0.4mm pitch

- v prefix indicates internal 60KOhm pull down resistor
- v prefix indicates internal 120KOhm pull down resistor
- ^ prefix indicates internal 120KOhm pull up resistor

## Power Management Table

CKPWRGD_PD#	SMBus OE bit	DIFx			REF
		OEx#	True O/P	Comp. O/P	
0	X	X	Low	Low	Hi-Z <sup>1</sup>
1	1	0	Running	Running	Running
1	0	1	Low	Low	Low

1. REF is Hi-Z until the 1st assertion of CKPWRGD\_PD# high. After this, when CKPWRGD\_PD# is low, REF is Low.

## SMBus Address Selection Table

	SADR	Address	+ Read/Write Bit
State of SADR on first application of CKPWRGD_PD#	0	1101000	x
	1	1101010	x

## Power Connections

Pin Number			Description
VDD	VDDIO	GND	
5		2	XTAL OSC
6		8	REF Power
12		9	Digital (dirty) Power
20,38	13,21,31,39,47	22,29,40	DIF outputs
30		29	PLL Analog

## Pin Descriptions

PIN #	PIN NAME	TYPE	DESCRIPTION
1	vSS_EN_tri	LATCHED IN	Latched select input to select spread spectrum amount at initial power up : 1 = -0.5% spread, M = -0.25%, 0 = Spread Off
2	GNDXTAL	GND	GND for XTAL
3	XIN/CLKIN_25	IN	Crystal input or Reference Clock input. Nominally 25MHz.
4	X2	OUT	Crystal output.
5	VDDXTAL1.5	PWR	Power supply for XTAL, nominal 1.5V
6	VDDREF1.5	PWR	VDD for REF output. nominal 1.5V.
7	vSADR/REF1.5	LATCHED I/O	Latch to select SMBus Address/1.5V LVCMOS copy of X1/REFIN pin
8	GNDREF	GND	Ground pin for the REF outputs.
9	GNDDIG	GND	Ground pin for digital circuitry
10	SCLK_3.3	IN	Clock pin of SMBus circuitry, 3.3V tolerant.
11	SDATA_3.3	I/O	Data pin for SMBus circuitry, 3.3V tolerant.
12	VDDDIG1.5	PWR	1.5V digital power (dirty power)
13	VDDIO	PWR	Power supply for differential outputs
14	vOE0#	IN	Active low input for enabling DIF pair 0. This pin has an internal pull-down. 1 =disable outputs, 0 = enable outputs
15	DIF0	OUT	Differential true clock output
16	DIF0#	OUT	Differential Complementary clock output
17	vOE1#	IN	Active low input for enabling DIF pair 1. This pin has an internal pull-down. 1 =disable outputs, 0 = enable outputs
18	DIF1	OUT	Differential true clock output
19	DIF1#	OUT	Differential Complementary clock output
20	VDD1.5	PWR	Power supply, nominally 1.5V
21	VDDIO	PWR	Power supply for differential outputs
22	GND	GND	Ground pin.
23	DIF2	OUT	Differential true clock output
24	DIF2#	OUT	Differential Complementary clock output
25	vOE2#	IN	Active low input for enabling DIF pair 2. This pin has an internal pull-down. 1 =disable outputs, 0 = enable outputs
26	DIF3	OUT	Differential true clock output
27	DIF3#	OUT	Differential Complementary clock output
28	vOE3#	IN	Active low input for enabling DIF pair 3. This pin has an internal pull-down. 1 =disable outputs, 0 = enable outputs
29	GNDA	GND	Ground pin for the PLL core.
30	VDDA1.5	PWR	1.5V power for the PLL core.
31	VDDIO	PWR	Power supply for differential outputs
32	DIF4	OUT	Differential true clock output
33	DIF4#	OUT	Differential Complementary clock output
34	vOE4#	IN	Active low input for enabling DIF pair 4. This pin has an internal pull-down. 1 =disable outputs, 0 = enable outputs
35	DIF5	OUT	Differential true clock output
36	DIF5#	OUT	Differential Complementary clock output
37	vOE5#	IN	Active low input for enabling DIF pair 5. This pin has an internal pull-down. 1 =disable outputs, 0 = enable outputs
38	VDD1.5	PWR	Power supply, nominally 1.5V
39	VDDIO	PWR	Power supply for differential outputs

## Pin Descriptions (cont.)

PIN #	PIN NAME	TYPE	DESCRIPTION
40	GND	GND	Ground pin.
41	DIF6	OUT	Differential true clock output
42	DIF6#	OUT	Differential Complementary clock output
43	vOE6#	IN	Active low input for enabling DIF pair 6. This pin has an internal pull-down. 1 =disable outputs, 0 = enable outputs
44	DIF7	OUT	Differential true clock output
45	DIF7#	OUT	Differential Complementary clock output
46	vOE7#	IN	Active low input for enabling DIF pair 7. This pin has an internal pull-down. 1 =disable outputs, 0 = enable outputs
47	VDDIO	PWR	Power supply for differential outputs
48	^CKPWRGD_PD#	IN	Input notifies device to sample latched inputs and start up on first high assertion. Low enters Power Down Mode, subsequent high assertions exit Power Down Mode. This pin has internal pull-up resistor.

### Test Loads

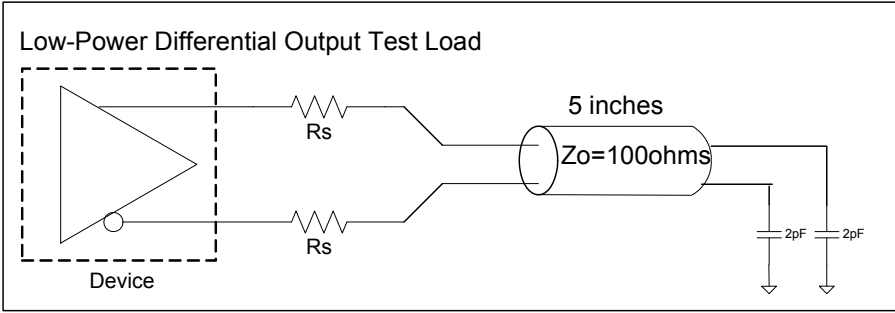

#### Alternate Differential Output Terminations

$R_s$	$Z_o$	Units
33	100	Ohms
27	85	

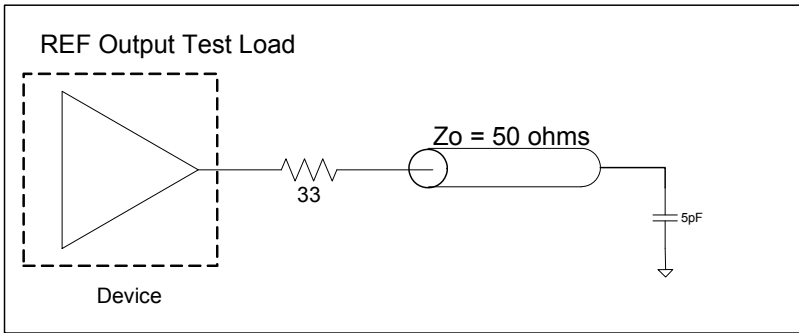

### Alternate Terminations

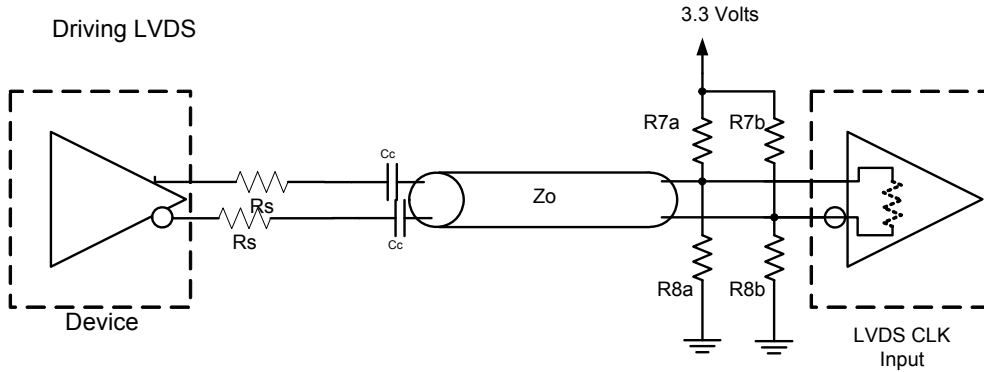

#### Driving LVDS inputs

Component	Value		Note
	Receiver has termination	Receiver does not have termination	
R7a, R7b	10K ohm	140 ohm	
R8a, R8b	5.6K ohm	75 ohm	
$C_c$	0.1 uF	0.1 uF	
$V_{cm}$	1.2 volts	1.2 volts	

## Absolute Maximum Ratings

Stresses above the ratings listed below can cause permanent damage to the 9FGV0831. These ratings, which are standard values for IDT commercially rated parts, are stress ratings only. Functional operation of the device at these or any other conditions above those indicated in the operational sections of the specifications is not implied. Exposure to absolute maximum rating conditions for extended periods can affect product reliability. Electrical parameters are guaranteed only over the recommended operating temperature range.

PARAMETER	SYMBOL	CONDITIONS	MIN	TYP	MAX	UNITS	NOTES
Supply Voltage	VDDxx	Applies to all VDD pins	-0.5		2	V	1,2
Input Voltage	V <sub>IN</sub>		-0.5		V <sub>DD</sub> +0.5V	V	1,3
Input High Voltage, SMBus	V <sub>IHSMB</sub>	SMBus clock and data pins			3.3V	V	1
Storage Temperature	T <sub>s</sub>		-65		150	°C	1
Junction Temperature	T <sub>j</sub>				125	°C	1
Input ESD protection	ESD prot	Human Body Model	2000			V	1

<sup>1</sup>Guaranteed by design and characterization, not 100% tested in production.

<sup>2</sup>Operation under these conditions is neither implied nor guaranteed.

<sup>3</sup>Not to exceed 2.5V.

## Electrical Characteristics – Current Consumption

TA = T<sub>AMB</sub>; Supply Voltages per normal operation conditions, See Test Loads for Loading Conditions

PARAMETER	SYMBOL	CONDITIONS	MIN	TYP	MAX	UNITS	NOTES
Operating Supply Current	I <sub>DDAOP</sub>	VDDA, All outputs active @100MHz		6.1	9	mA	
	I <sub>DDOP</sub>	All VDD, except VDDA and VDDIO, All outputs active @100MHz		9.2	14	mA	
	I <sub>DDIOOP</sub>	VDDIO, All outputs active @100MHz		26	38	mA	
Wake-on-LAN Current (CKPWRGD_PD# = '0' Byte 3, bit 5 = '1')	I <sub>DDAPD</sub>	VDDA, DIF outputs off, REF output running		0.4	1	mA	2
	I <sub>DDPD</sub>	All VDD, except VDDA and VDDIO, DIF outputs off, REF output running		4.4	7	mA	2
	I <sub>DDIOPD</sub>	VDDIO, DIF outputs off, REF output running		0.04	0.1	mA	2
Powerdown Current (CKPWRGD_PD# = '0' Byte 3, bit 5 = '0')	I <sub>DDAPD</sub>	VDDA, all outputs off		0.4	1	mA	
	I <sub>DDPD</sub>	All VDD, except VDDA and VDDIO, all outputs off		0.4	1	mA	
	I <sub>DDIOPD</sub>	VDDIO, all outputs off		0.0003	0.1	mA	

<sup>1</sup>Guaranteed by design and characterization, not 100% tested in production.

<sup>2</sup>This is the current required to have the REF output running in Wake-on-LAN mode (Byte 3, bit 5 = 1)

## Electrical Characteristics – DIF Output Duty Cycle, Jitter, and Skew Characteristics

TA = T<sub>AMB</sub>; Supply Voltages per normal operation conditions, See Test Loads for Loading Conditions

PARAMETER	SYMBOL	CONDITIONS	MIN	TYP	MAX	UNITS	NOTES
Duty Cycle	t <sub>DC</sub>	Measured differentially, PLL Mode	45	50	55	%	1,2
Skew, Output to Output	t <sub>sk3</sub>	Averaging on, V <sub>T</sub> = 50%		32	60	ps	1
Jitter, Cycle to cycle	t <sub>jcyc-cyc</sub>			16	50	ps	1,2

<sup>1</sup>Guaranteed by design and characterization, not 100% tested in production.

<sup>2</sup>Measured from differential waveform

## Electrical Characteristics – Input/Supply/Common Parameters - Normal Operating Conditions

TA = T<sub>AMB</sub>; Supply Voltages per normal operation conditions, See Test Loads for Loading Conditions

PARAMETER	SYMBOL	CONDITIONS	MIN	TYP	MAX	UNITS	NOTES
Supply Voltage	VDDXX	Supply voltage for core, analog and single-ended LVCMOS outputs	1.425	1.5	1.575	V	
Output Supply Voltage	VDDIO	Supply voltage for differential Low Power Outputs	0.9975	1.05-1.5	1.575	V	
Ambient Operating Temperature	T <sub>AMB</sub>	Comercial range	0	25	70	°C	
		Industrial range	-40	25	85	°C	
Input High Voltage	V <sub>IH</sub>	Single-ended inputs, except SMBus	0.75 V <sub>DD</sub>		V <sub>DD</sub> + 0.3	V	
Input Mid Voltage	V <sub>IM</sub>	Single-ended tri-level inputs ('_tri' suffix)	0.4 V <sub>DD</sub>	0.5 V <sub>DD</sub>	0.6 V <sub>DD</sub>	V	
Input Low Voltage	V <sub>IL</sub>	Single-ended inputs, except SMBus	-0.3		0.25 V <sub>DD</sub>	V	
Output High Voltage	V <sub>IH</sub>	Single-ended outputs, except SMBus. I <sub>OH</sub> = -2mA	V <sub>DD</sub> -0.45			V	
Output Low Voltage	V <sub>IL</sub>	Single-ended outputs, except SMBus. I <sub>OL</sub> = -2mA			0.45	V	
Input Current	I <sub>IN</sub>	Single-ended inputs, V <sub>IN</sub> = GND, V <sub>IN</sub> = VDD	-5		5	uA	
	I <sub>INP</sub>	Single-ended inputs V <sub>IN</sub> = 0 V; Inputs with internal pull-up resistors V <sub>IN</sub> = VDD; Inputs with internal pull-down resistors	-200		200	uA	
Input Frequency	F <sub>in</sub>	XTAL, or X1 input	23	25	27	MHz	
Pin Inductance	L <sub>pin</sub>				7	nH	1
Capacitance	C <sub>IN</sub>	Logic Inputs, except DIF_IN	1.5		5	pF	1
	C <sub>OUT</sub>	Output pin capacitance			6	pF	1
Clk Stabilization	T <sub>STAB</sub>	From V <sub>DD</sub> Power-Up and after input clock stabilization or de-assertion of PD# to 1st clock			1.8	ms	1,2
SS Modulation Frequency	f <sub>MOD</sub>	Triangular Modulation	30	31.6	33	kHz	1
OE# Latency	t <sub>LATOE#</sub>	DIF start after OE# assertion DIF stop after OE# deassertion	1		3	clocks	1,3
Tdrive_PD#	t <sub>DRVDPD</sub>	DIF output enable after PD# de-assertion			300	us	1,3
Tfall	t <sub>F</sub>	Fall time of single-ended control inputs			5	ns	2
Trise	t <sub>R</sub>	Rise time of single-ended control inputs			5	ns	2
SMBus Input Low Voltage	V <sub>ILSMB</sub>				0.6	V	
SMBus Input High Voltage	V <sub>IHSMB</sub>	V <sub>DD</sub> SMB = 3.3V, see note 4 for V <sub>DD</sub> SMB < 3.3V	2.1		3.3	V	4
SMBus Output Low Voltage	V <sub>OLSMB</sub>	@ I <sub>PULLUP</sub>			0.4	V	
SMBus Sink Current	I <sub>PULLUP</sub>	@ V <sub>OL</sub>	4			mA	
Nominal Bus Voltage	V <sub>DD</sub> SMB		1.425		3.3	V	
SCLK/SDATA Rise Time	t <sub>RSMB</sub>	(Max V <sub>IL</sub> - 0.15) to (Min V <sub>IH</sub> + 0.15)			1000	ns	1
SCLK/SDATA Fall Time	t <sub>FSMB</sub>	(Min V <sub>IH</sub> + 0.15) to (Max V <sub>IL</sub> - 0.15)			300	ns	1
SMBus Operating Frequency	f <sub>MAX</sub> SMB	Maximum SMBus operating frequency			400	kHz	1

<sup>1</sup> Guaranteed by design and characterization, not 100% tested in production.

<sup>2</sup> Control input must be monotonic from 20% to 80% of input swing.

<sup>3</sup> Time from deassertion until outputs are >200 mV

<sup>4</sup> For V<sub>DD</sub>SMB < 3.3V, V<sub>IHSMB</sub> >= 0.8xV<sub>DD</sub>SMB

## Electrical Characteristics – DIF Low-Power HCSL Outputs

TA = T<sub>AMB</sub>; Supply Voltages per normal operation conditions, See Test Loads for Loading Conditions

PARAMETER	SYMBOL	CONDITIONS	MIN	TYP	MAX	UNITS	NOTES
Slew rate	Trf	Scope averaging on fast setting	1.1	2.2	3.3	V/ns	1,2,3
		Scope averaging on slow setting	0.9	1.7	2.6	V/ns	1,2,3
Slew rate matching	ΔTrf	Slew rate matching, Scope averaging on		3	20	%	1,2,4
Voltage High	V <sub>HIGH</sub>	Statistical measurement on single-ended signal using oscilloscope math function. (Scope averaging on)	600	735	850	mV	7
Voltage Low	V <sub>LOW</sub>		-150	-16	150		7
Max Voltage	V <sub>max</sub>	Measurement on single ended signal using absolute value. (Scope averaging off)		779	1150	mV	7
Min Voltage	V <sub>min</sub>		-300	-45			7
Vswing	Vswing	Scope averaging off	300	1503		mV	1,2,7
Crossing Voltage (abs)	V <sub>cross_abs</sub>	Scope averaging off	250	405	550	mV	1,5,7
Crossing Voltage (var)	Δ-V <sub>cross</sub>	Scope averaging off		12	140	mV	1,6,7

<sup>1</sup>Guaranteed by design and characterization, not 100% tested in production.

<sup>2</sup> Measured from differential waveform

<sup>3</sup> Slew rate is measured through the Vswing voltage range centered around differential 0V. This results in a +/-150mV window around differential 0V.

<sup>4</sup> Matching applies to rising edge rate for Clock and falling edge rate for Clock#. It is measured using a +/-75mV window centered on the average cross point where Clock rising meets Clock# falling. The median cross point is used to calculate the voltage thresholds the oscilloscope is to use for the edge rate calculations.

<sup>5</sup> V<sub>cross</sub> is defined as voltage where Clock = Clock# measured on a component test board and only applies to the differential rising edge (i.e. Clock rising and Clock# falling).

<sup>6</sup> The total variation of all V<sub>cross</sub> measurements in any particular system. Note that this is a subset of V<sub>cross\_min/max</sub> (V<sub>cross</sub> absolute) allowed. The intent is to limit V<sub>cross</sub> induced modulation by setting Δ-V<sub>cross</sub> to be smaller than V<sub>cross</sub> absolute.

<sup>7</sup> At default SMBus amplitude settings.

## Electrical Characteristics – DIF Output Phase Jitter Parameters

TA = T<sub>AMB</sub>; Supply Voltages per normal operation conditions, See Test Loads for Loading Conditions

PARAMETER	SYMBOL	CONDITIONS	MIN	TYP	MAX	IND. LIMIT	UNITS	Notes
Phase Jitter, PLL Mode	t <sub>jphPCIEG1</sub>	PCIe Gen 1		27.7	40	86	ps (p-p)	1,2,3,5
	t <sub>jphPCIEG2</sub>	PCIe Gen 2 Lo Band 10kHz < f < 1.5MHz		1.0	1.3	3	ps (rms)	1,2,3,5
		PCIe Gen 2 High Band 1.5MHz < f < Nyquist (50MHz)		1.9	2.2	3.1	ps (rms)	1,2,3,5
	t <sub>jphPCIEG3</sub>	PCIe Gen 3 Common Clock Architecture (PLL BW of 2-4 or 2-5MHz, CDR = 10MHz)		0.4	0.6	1	ps (rms)	1,2,3,5
t <sub>jphPCIEG3SRn</sub> s	PCIe Gen 3 Separate Reference No Spread (SRnS) (PLL BW of 2-4 or 2-5MHz, CDR = 10MHz)		0.4	0.6	0.7	ps (rms)	1,2,3,5	

<sup>1</sup> Guaranteed by design and characterization, not 100% tested in production.

<sup>2</sup> See <http://www.pcisig.com> for complete specs

<sup>3</sup> Sample size of at least 100K cycles. This figures extrapolates to 108ps pk-pk @ 1M cycles for a BER of 1-12.

<sup>4</sup> Calculated from Intel-supplied Clock Jitter Tool

<sup>5</sup> Applies to all differential outputs

## Electrical Characteristics – REF

TA = T<sub>AMB</sub>; Supply Voltages per normal operation conditions, See Test Loads for Loading Conditions

PARAMETER	SYMBOL	CONDITIONS	MIN	TYP	MAX	UNITS	Notes
Long Accuracy	ppm	see T <sub>period</sub> min-max values		0		ppm	1,2
Clock period	T <sub>period</sub>	25 MHz output		40		ns	2
Rise/Fall Slew Rate	t <sub>rf1</sub>	Byte 3 = 1F, 20% to 80% of VDDREF	0.3	0.7	1.1	V/ns	1
Rise/Fall Slew Rate	t <sub>rf1</sub>	Byte 3 = 5F, 20% to 80% of VDDREF	0.5	1.0	1.6	V/ns	1,3
Rise/Fall Slew Rate	t <sub>rf1</sub>	Byte 3 = 9F, 20% to 80% of VDDREF	0.77	1.3	1.9	V/ns	1
Rise/Fall Slew Rate	t <sub>rf1</sub>	Byte 3 = DF, 20% to 80% of VDDREF	0.84	1.4	2.0	V/ns	1
Duty Cycle	d <sub>t1X</sub>	V <sub>T</sub> = VDD/2 V	45	47.1	55	%	1,4
Duty Cycle Distortion	d <sub>tcd</sub>	V <sub>T</sub> = VDD/2 V, when driven by XIN/CLKIN_25 pin	0	2	4	%	1,5
Jitter, cycle to cycle	t <sub>jcyc-cyc</sub>	V <sub>T</sub> = VDD/2 V		51.2	250	ps	1,4
Noise floor	t <sub>dBc1k</sub>	1kHz offset		-126	-105	dBc	1,4
Noise floor	t <sub>dBc10k</sub>	10kHz offset to Nyquist		-139	-110	dBc	1,4
Jitter, phase	t <sub>jphREF</sub>	12kHz to 5MHz		1.11	3	ps (rms)	1,4

<sup>1</sup>Guaranteed by design and characterization, not 100% tested in production.

<sup>2</sup>All Long Term Accuracy and Clock Period specifications are guaranteed assuming that REF is trimmed to 25.00 MHz

<sup>3</sup>Default SMBus Value

<sup>4</sup>When driven by a crystal.

<sup>5</sup>X2 should be floating.

## Clock Periods - Differential Outputs with Spread Spectrum Disabled

SSC OFF	Center Freq. MHz	Measurement Window							Units	Notes
		1 Clock	1us	0.1s	0.1s	0.1s	1us	1 Clock		
		-c2c jitter AbsPer Min	-SSC Short-Term Average Min	- ppm Long-Term Average Min	0 ppm Period Nominal	+ ppm Long-Term Average Max	+SSC Short-Term Average Max	+c2c jitter AbsPer Max		
DIF	100.00	9.94900		9.99900	10.00000	10.00100		10.05100	ns	1,2

## Clock Periods - Differential Outputs with Spread Spectrum Enabled

SSC ON	Center Freq. MHz	Measurement Window							Units	Notes
		1 Clock	1us	0.1s	0.1s	0.1s	1us	1 Clock		
		-c2c jitter AbsPer Min	-SSC Short-Term Average Min	- ppm Long-Term Average Min	0 ppm Period Nominal	+ ppm Long-Term Average Max	+SSC Short-Term Average Max	+c2c jitter AbsPer Max		
DIF	99.75	9.94906	9.99906	10.02406	10.02506	10.02607	10.05107	10.10107	ns	1,2

<sup>1</sup>Guaranteed by design and characterization, not 100% tested in production.

<sup>2</sup>All Long Term Accuracy and Clock Period specifications are guaranteed assuming that REF is trimmed to 25.00 MHz

## General SMBUS Serial Interface Information

### How to Write

- Controller (host) sends a start bit
- Controller (host) sends the write address
- IDT clock will **acknowledge**
- Controller (host) sends the beginning byte location = N
- IDT clock will **acknowledge**
- Controller (host) sends the byte count = X
- IDT clock will **acknowledge**
- Controller (host) starts sending Byte **N through Byte N+X-1**
- IDT clock will **acknowledge** each byte **one at a time**
- Controller (host) sends a Stop bit

### How to Read

- Controller (host) will send a start bit
- Controller (host) sends the write address
- IDT clock will **acknowledge**
- Controller (host) sends the beginning byte location = N
- IDT clock will **acknowledge**
- Controller (host) will send a separate start bit
- Controller (host) sends the read address
- IDT clock will **acknowledge**
- IDT clock will send the data byte count = X
- IDT clock sends Byte **N+X-1**
- IDT clock sends **Byte 0 through Byte X (if X<sub>(H)</sub> was written to Byte 8)**
- Controller (host) will need to acknowledge each byte
- Controller (host) will send a not acknowledge bit
- Controller (host) will send a stop bit

Index Block Write Operation		
Controller (Host)		IDT (Slave/Receiver)
T	starT bit	
Slave Address		
WR	WRite	
		ACK
Beginning Byte = N		
		ACK
Data Byte Count = X		
		ACK
Beginning Byte N		
		ACK
O		X Byte
O		
O		
Byte N + X - 1		
		ACK
P	stoP bit	

**Note: SMBus address is Latched on SADR pin.**

Index Block Read Operation		
Controller (Host)		IDT (Slave/Receiver)
T	starT bit	
Slave Address		
WR	WRite	
		ACK
Beginning Byte = N		
		ACK
RT	Repeat starT	
Slave Address		
RD	ReaD	
		ACK
ACK		
		Data Byte Count=X
ACK		Beginning Byte N
O		X Byte
O		
O		
O		
		Byte N + X - 1
N	Not acknowledge	
P	stoP bit	

**SMBus Table: Output Enable Register <sup>1</sup>**

Byte 0	Name	Control Function	Type	0	1	Default
Bit 7	DIF OE7	Output Enable	RW	Low/Low	Enabled	1
Bit 6	DIF OE6	Output Enable	RW	Low/Low	Enabled	1
Bit 5	DIF OE5	Output Enable	RW	Low/Low	Enabled	1
Bit 4	DIF OE4	Output Enable	RW	Low/Low	Enabled	1
Bit 3	DIF OE3	Output Enable	RW	Low/Low	Enabled	1
Bit 2	DIF OE2	Output Enable	RW	Low/Low	Enabled	1
Bit 1	DIF OE1	Output Enable	RW	Low/Low	Enabled	1
Bit 0	DIF OE0	Output Enable	RW	Low/Low	Enabled	1

1. A low on these bits will override the OE# pin and force the differential output Low/Low

**SMBus Table: SS Readback and Control Register**

Byte 1	Name	Control Function	Type	0	1	Default
Bit 7	SSENRB1	SS Enable Readback Bit1	R	00' for SS_EN_tri = 0, '01' for SS_EN_tri = 'M', '11 for SS_EN_tri = '1'		Latch
Bit 6	SSENRB1	SS Enable Readback Bit0	R			Latch
Bit 5	SSEN_SWCNTRL	Enable SW control of SS	RW	Values in B1[7:6] control SS amount	Values in B1[4:3] control SS amount.	0
Bit 4	SSENSW1	SS Enable Software Ctl Bit1	RW <sup>1</sup>	00' = SS Off, '01' = -0.25% SS, '10' = Reserved, '11' = -0.5% SS		0
Bit 3	SSENSW0	SS Enable Software Ctl Bit0	RW <sup>1</sup>			0
Bit 2	Reserved					1
Bit 1	AMPLITUDE 1	Controls Output Amplitude	RW	00 = 0.55V	01 = 0.65V	1
Bit 0	AMPLITUDE 0		RW	10 = 0.7V	11 = 0.8V	0

1. B1[5] must be set to a 1 for these bits to have any effect on the part.

**SMBus Table: DIF Slew Rate Control Register**

Byte 2	Name	Control Function	Type	0	1	Default
Bit 7	SLEWRATESEL DIF7	Adjust Slew Rate of DIF7	RW	Slow Setting	Fast Setting	1
Bit 6	SLEWRATESEL DIF6	Adjust Slew Rate of DIF6	RW	Slow Setting	Fast Setting	1
Bit 5	SLEWRATESEL DIF5	Adjust Slew Rate of DIF5	RW	Slow Setting	Fast Setting	1
Bit 4	SLEWRATESEL DIF4	Adjust Slew Rate of DIF4	RW	Slow Setting	Fast Setting	1
Bit 3	SLEWRATESEL DIF3	Adjust Slew Rate of DIF3	RW	Slow Setting	Fast Setting	1
Bit 2	SLEWRATESEL DIF2	Adjust Slew Rate of DIF2	RW	Slow Setting	Fast Setting	1
Bit 1	SLEWRATESEL DIF1	Adjust Slew Rate of DIF1	RW	Slow Setting	Fast Setting	1
Bit 0	SLEWRATESEL DIF0	Adjust Slew Rate of DIF0	RW	Slow Setting	Fast Setting	1

**SMBus Table: Nominal Vhigh Amplitude Control/ REF Control Register**

Byte 3	Name	Control Function	Type	0	1	Default
Bit 7	REF	Slew Rate Control	RW	00 = Slowest	01 = Slow	0
Bit 6			RW	10 = Fast	11 = Faster	1
Bit 5	REF Power Down Function	Wake-on-Lan Enable for REF	RW	REF does not run in Power Down	REF runs in Power Down	0
Bit 4	REF OE	REF Output Enable	RW	Low	Enabled	1
Bit 3	Reserved					1
Bit 2	Reserved					1
Bit 1	Reserved					1
Bit 0	Reserved					1

Byte 4 is Reserved

**SMBus Table: Revision and Vendor ID Register**

Byte 5	Name	Control Function	Type	0	1	Default
Bit 7	RID3	Revision ID	R	C rev = 0001		0
Bit 6	RID2		R			0
Bit 5	RID1		R			0
Bit 4	RID0		R			1
Bit 3	VID3	VENDOR ID	R	0001 = IDT		0
Bit 2	VID2		R			0
Bit 1	VID1		R			0
Bit 0	VID0		R			1

**SMBus Table: Device Type/Device ID**

Byte 6	Name	Control Function	Type	0	1	Default
Bit 7	Device Type1	Device Type	R	00 = FGx, 01 = DBx ZDB/FOB, 10 = DMx, 11= DBx FOB		0
Bit 6	Device Type0		R			0
Bit 5	Device ID5	Device ID	R	001000 binary or 08 hex		0
Bit 4	Device ID4		R			0
Bit 3	Device ID3		R			1
Bit 2	Device ID2		R			0
Bit 1	Device ID1		R			0
Bit 0	Device ID0		R			0

**SMBus Table: Byte Count Register**

Byte 7	Name	Control Function	Type	0	1	Default
Bit 7		Reserved				0
Bit 6		Reserved				0
Bit 5		Reserved				0
Bit 4	BC4	Byte Count Programming	RW	Writing to this register will configure how many bytes will be read back, default is = 8 bytes.		0
Bit 3	BC3		RW			1
Bit 2	BC2		RW			0
Bit 1	BC1		RW			0
Bit 0	BC0		RW			0

## Recommended Crystal Characteristics (3225 package)

PARAMETER	VALUE	UNITS	NOTES
Frequency	25	MHz	1
Resonance Mode	Fundamental	-	1
Frequency Tolerance @ 25°C	±20	PPM Max	1
Frequency Stability, ref @ 25°C Over Operating Temperature Range	±20	PPM Max	1
Temperature Range (commercial)	0~70	°C	1
Temperature Range (industrial)	-40~85	°C	2
Equivalent Series Resistance (ESR)	50	Ω Max	1
Shunt Capacitance (C <sub>O</sub> )	7	pF Max	1
Load Capacitance (C <sub>L</sub> )	8	pF Max	1
Drive Level	0.3	mW Max	1
Aging per year	±5	PPM Max	1

**Notes:**

1. FOX 603-25-150.
2. For I-temp, FOX 603-25-261.

## Thermal Characteristics

PARAMETER	SYMBOL	CONDITIONS	PKG	TYP.	UNITS	NOTES
Thermal Resistance	$\theta_{JC}$	Junction to Case	NDG48	33	°C/W	1
	$\theta_{Jb}$	Junction to Base		2.1	°C/W	1
	$\theta_{JA0}$	Junction to Air, still air		37	°C/W	1
	$\theta_{JA1}$	Junction to Air, 1 m/s air flow		30	°C/W	1
	$\theta_{JA3}$	Junction to Air, 3 m/s air flow		27	°C/W	1
	$\theta_{JA5}$	Junction to Air, 5 m/s air flow		26	°C/W	1

<sup>1</sup>ePad soldered to board

## Marking Diagrams

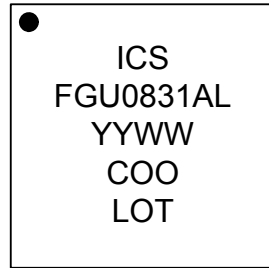
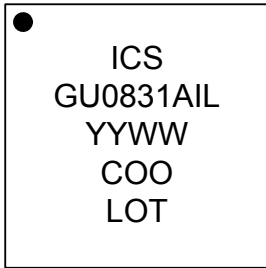

### Notes:

- Line 2 is the truncated part number.
- 'L' denotes RoHS compliant package.
- 'I' denotes industrial temperature grade.
- 'YYWW' is the last two digits of the year and week that the part was assembled.
- 'COO' denotes country of origin.
- 'LOT' is the lot number.



## Revision History

Rev.	Issue Date	Initiator	Description	Page #
A	9/24/2014	RDW	1. Updated electrical tables with latest versions for release. 2. Updated SMBus nomenclature for consistency with the family. 3. Removed references to Suspend Mode – and the Suspend Rail. This is replaced by Power Down with Wake-on-LAN modes in the current consumption table. 4. Updated GenDes tab for front page consistency. 5. Move to final.	Various
B	10/18/2016	RDW	Removed IDT crystal part number	



**Corporate Headquarters**  
6024 Silver Creek Valley Road  
San Jose, CA 95138 USA

**Sales**  
1-800-345-7015 or 408-284-8200  
Fax: 408-284-2775  
www.IDT.com

**Tech Support**  
email: [clocks@idt.com](mailto:clocks@idt.com)

DISCLAIMER Integrated Device Technology, Inc. (IDT) and its subsidiaries reserve the right to modify the products and/or specifications described herein at any time and at IDT's sole discretion. All information in this document, including descriptions of product features and performance, is subject to change without notice. Performance specifications and the operating parameters of the described products are determined in the independent state and are not guaranteed to perform the same way when installed in customer products. The information contained herein is provided without representation or warranty of any kind, whether express or implied, including, but not limited to, the suitability of IDT's products for any particular purpose, an implied warranty of merchantability, or non-infringement of the intellectual property rights of others. This document is presented only as a guide and does not convey any license under intellectual property rights of IDT or any third parties.

IDT's products are not intended for use in applications involving extreme environmental conditions or in life support systems or similar devices where the failure or malfunction of an IDT product can be reasonably expected to significantly affect the health or safety of users. Anyone using an IDT product in such a manner does so at their own risk, absent an express, written agreement by IDT.

Integrated Device Technology, IDT and the IDT logo are registered trademarks of IDT. Product specification subject to change without notice. Other trademarks and service marks used herein, including protected names, logos and designs, are the property of IDT or their respective third party owners.

Copyright ©2016 Integrated Device Technology, Inc.. All rights reserved.