

APPROVAL SHEET



WQAC292 Series
SMD Air Wound Coil Inductors
AEC-Q200

*Contents in this sheet are subject to change without prior notice.

Features

Acrylic jacket(WQAC292) provides a flat top for pick and place

1. Acrylic cap provides a flat top for pick and place machine for high productive manufacture.
2. Excellent Q and SRF characteristics for RF application, especially in subGHz band.
3. Narrow tolerance available for precise design requirements.
4. AEC-Q200

Applications

1. Communication system front-end circuit: GSM/3G/LTE, Wi-Fi, GPS.
2. Cabel/Terrestrial/BS Tuner, Bluetooth, Wireless Audio, Remote control.
3. M2M: ZigBee, Proprietary wireless.
4. EMI solution in high frequency circuits.
5. Automotive

Shape and Dimension

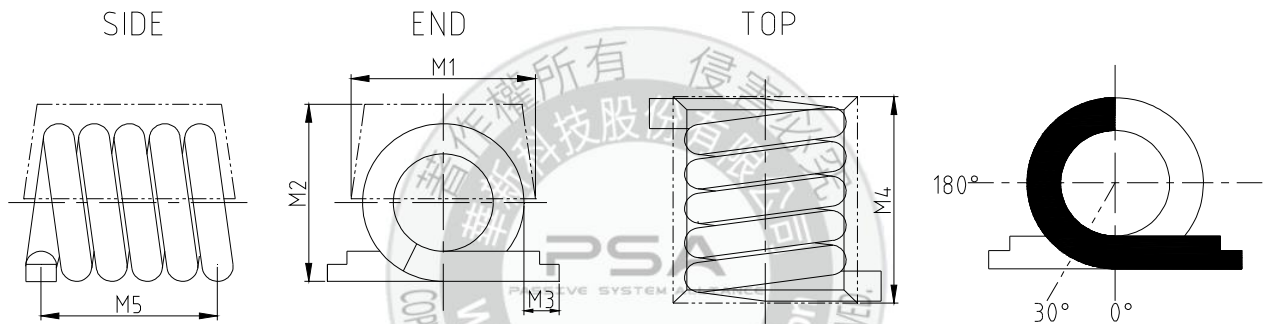

Recommend Patterns

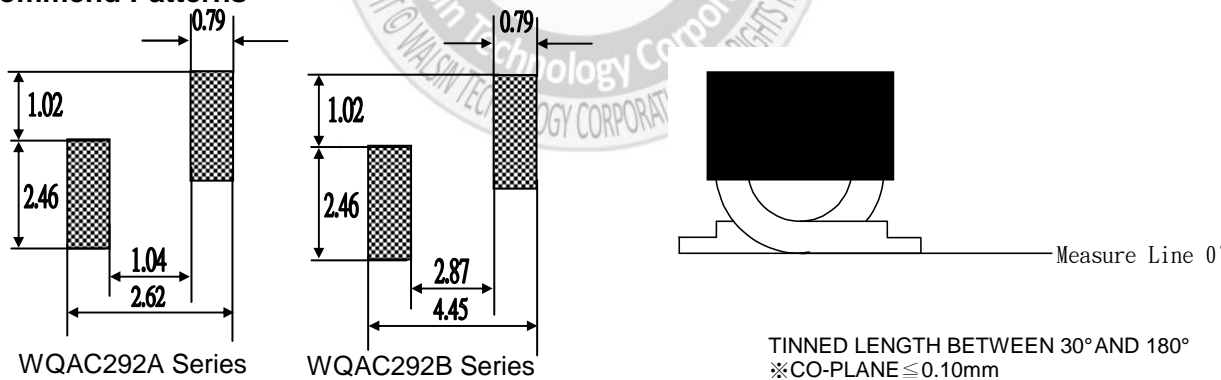

Unit: mm

WQAC Series	M1	M2	M3	M4	M5
292A	1.42±0.13	1.37±0.15	0.89±0.25	2.21±0.25	1.83±0.25
292B	1.42±0.13	1.37±0.15	0.89±0.25	4.04±0.30	3.66±0.30

Ordering Information

WQ	AC	292A	Z0	K	T02	P	B
Product Code WQ: Inductor AEC-Q200	Series Air wound coil inductor.	Dimensions 292A 292B	Series Extension Z0:STD	Tolerance G: ± 2% J: ± 5% K: ± 10%	Value T02 = 2Turns T10 =10Turns	Packing Code P=7" Reeled (Embossed reel)	B:STD

Electrical Characteristics

● WQAC292 series

Walsin Part Number	Turns	L(nH)	Tolerance	Q Min	Typical Q @ Frequency (MHz)	SRF Maximum (GHz)	RDC Maximum (mΩ)	Rated Current Maximum (A)
WQAC292AZ0□T02PB	2	1.65	K	100	800	10	4	1.6
WQAC292AZ0□T03PB	3	2.55	J、K	100	800	8.2	5	1.6
WQAC292AZ0□T04PB	4	3.85	G、J、K	100	800	7.5	6	1.6
WQAC292AZ0□T05PB	5	5.4	G、J	100	800	7	8	1.6
WQAC292BZ0□T06PB	6	5.6	G、J	100	800	6.5	9	1.6
WQAC292BZ0□T07PB	7	7.15	G、J	100	800	6	10	1.6
WQAC292BZ0□T08PB	8	8.8	G、J	100	800	6	12	1.6
WQAC292BZ0□T09PB	9	9.85	G、J	100	800	5.2	13	1.6
WQAC292BZ0□T10PB	10	12.55	G、J	100	800	4.6	14	1.6

TOLERANCE : G=±2%, J=±5%, K=±10%

※TEST INSTRUMENT: HP4291B、FIXTURE HP16193A、HP8753E、CHROMA16502

NOTE : 1. Inductance & Q measured on the HP4291B. With HP16193A test fixture.

2. SRF measured using the HP8753E

3. Operating temperature range: -40°C to +125°C.

4. Electrical specifications at 25°C.

5. MSL : LEVEL 1

RELIABILITY PERFORMANCE

Test Item	Test Condition	Standard Source
High Temperature Exposure (Storage)	1000 hrs. at rated operating temperature (e.g. 125°C part can be stored for 1000 hrs. @ 125°C. Same applies for 105°C and 85°C. Unpowered. Measurement at 24±4 hours after test conclusion.	MIL-STD-202 Method 108
Temperature Cycling	1000 cycles (-40°C to +125°C). Note: If 85°C part or 105°C part the 1000 cycles will be at that temperature. Measurement at 24±4 hours after test conclusion. 30min maximum dwell time at each temperature extreme. 1 min. maximum transition time.	JESD22 Method JA-104
Biased Humidity	1000 hours 85°C/85%RH. Unpowered. Measurement at 24±4 hours after test conclusion.	MIL-STD-202 Method 103
Operational Life	1000 hrs. @ 105°C. If 85°C or 125°C part will be tested at that temperature. Measurement at 24±4 hours after test conclusion.	MIL-PRF-27
Mechanical Shock	Method 213. Condition C, Peak Value: 100g's, Duration: 6ms, Waveform: Half-sine Velocity Change: 12.3ft/sec	MIL-STD-202 Method 213
Vibration	5g's for 20 minutes, 12 cycles each of 3 orientations. Note: Use 8"X5" PCB, .031" thick, 7 secure points on one long side and 2 secure points at corners of opposite sides. Parts mounted within 2" from any secure point. Test from 10-2000 Hz.	MIL-STD-202 Method 204
Resistance to Soldering Heat	Condition B No pre-heat of samples. Note: Single Wave Solder - Procedure 2 for SMD and Procedure 1 for Leaded with solder within 1.5mm of device body.	MIL-STD-202 Method 210
ESD	Passive Component Human Body Model (HBM) Electrostatic Discharge (ESD) Test. Only direct contact discharge, record the voltage value what the sample can pass.	AEC-Q200-002 Or ISO/DIS10605
Solderability	For both Leaded & SMD. Electrical Test not required. Magnification 50X. Conditions: Leaded: Method A @ 235°C, category 3. SMD: a) Method B, 4 hrs @ 155°C dry heat @ 235°C b) Method B @ 215°C category 3. c) Method D category 3 @ 260°C.	J-STD-002
Flammability	V-0 or V-1 Acceptable	UL-94
Board Flex	60 sec minimum holding time.	AEC-Q200-005
Terminal Strength (SMD)	Force of 1.8kg for 60 seconds.	AEC-Q200-006

Typical RoHS Reflow Profile

Typical RoHS Reflow Profile

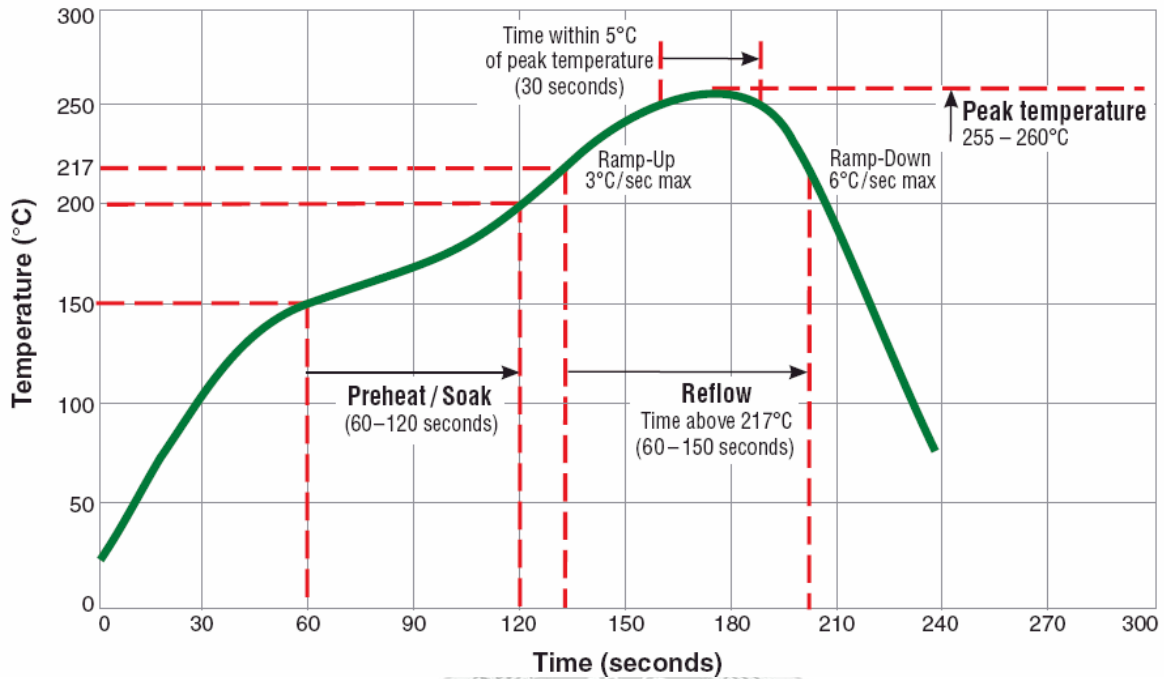

Packaging Specification

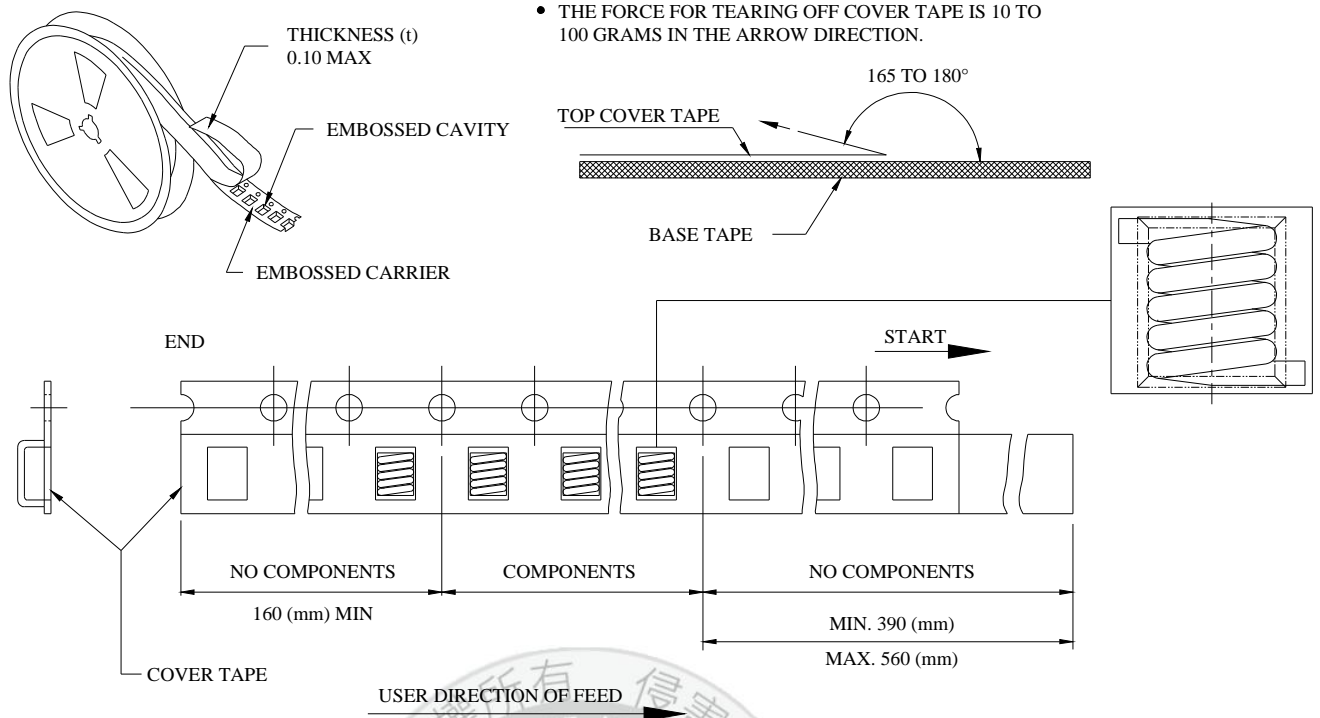

■ CARRIER TAPE REELS (mm)

MATERIAL: PLASTIC

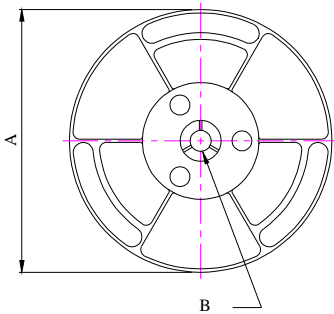

■ DIMENSIONS OF CARRIER TAPE (mm)

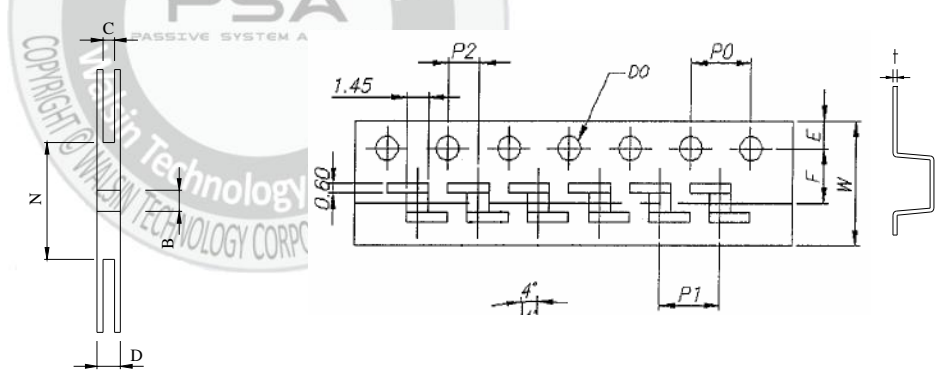

Unit : mm

292A	A	B	C	D	E	F	N	t	W	D0	P0	P1	P2
DIM.	178	13	8.4	12.5	1.75	3.50	75	0.23	8.0	1.50	4.00	4.00	2.00
TOL.	±2.0	±0.8	+1.5 -0	+1.5 -0	±0.10	±0.10	±2.0	±0.05	±0.20	+0.10 -0	±0.10	±0.10	±0.10
292B	A	B	C	D	E	F	N	t	W	D0	P0	P1	P2
DIM.	180	13	12.4	16.8	1.75	3.50	50	0.35	12	1.50	4.00	4.00	2.00
TOL.	MAX.	+0.5 -0.2	+2 -0	MAX.	±0.10	±0.10	MIN.	±0.05	±0.30	+0.10 -0	±0.10	±0.10	±0.10

Quantity per reel : 2K pcs