



Size: 0.50in x 0.40in x 0.30in (12.70mm x 10.16mm x 7.70in)

FEATURES

- Single Channel
- High Speed
- Compact Size
- CAN Isolation Transceiver Module
- Two-Port Isolation: 2.5kVDC
- High Baud Rate Up to 1Mbps
- RoHS Compliant
- Bus Timeout Protection
- Bus Can Support at Least 110 Nodes
- Standard DIP8 Package
- Meets ISO 11898-2 Standard
- EN60950 Safety Approval
- 3 Year Warranty

DESCRIPTION

The RBCAN01 series of CAN isolation transceiver module is a single channel, high speed, industrial bus that converts TTL/CMOS level to CAN bus differential level and achieves signal isolation. This series consists of very compact models with a standard DIP8 package and a bus that can support at least 110 nodes. It features two-port isolation of 2.5kVDC, baud rate up to 1Mbps, and bus timeout protection. This series is RoHS compliant, meets ISO 11898-2 standard, and also has EN60950 safety approvals.

MODEL SELECTION TABLE

Model Number	Input Voltage	Static Current	Max. Operating Current	Bus Maximum Voltage	Baud Rate	Number of Nodes	Certification
RBCAN01-360	3.3VDC	30mA	60mA	±58V	40k-1Mbps	110	CE
RBCAN01-550	5VDC	24mA	50mA	±58V	40k-1Mbps	110	

SPECIFICATIONS

All specifications are based on 25°C, Humidity <75%, Nominal Input Voltage, and Rated Output Load unless otherwise noted. We reserve the right to change specifications based on technological advances.

SPECIFICATION	TEST CONDITIONS		Min	Typ	Max	Unit
INPUT SPECIFICATIONS						
Input Voltage	Symbol: VCC	RBCAN01-360 Model	3.15	3.3	3.45	VDC
		RBCAN01-550 Model	4.75	5	5.25	
Input Surge Voltage	1 sec. max	RBCAN01-360 Model	-0.7		5	VDC
		RBCAN01-550 Model	-0.7		7	
TXD Logic Level (High Level)	Symbol: V _{IH}	RBCAN01-360 Model	2		3.6	VDC
		RBCAN01-550 Model	2		5.5	
TXD Logic Level (Low Level)	Symbol: V _{IL}	RBCAN01-360 Model	0		0.8	VDC
		RBCAN01-550 Model	0		0.8	
RXD Logic Level (High Level)	Symbol: V _{OH}	RBCAN01-360 Model	VCC-0.4	3.1		VDC
		RBCAN01-550 Model	VCC-0.4	4.8		
RXD Logic Level (Low Level)	Symbol: V _{OL}	RBCAN01-360 Model		0.2	0.4	VDC
		RBCAN01-550 Model		0.2	0.4	
TXD Drive Current	Symbol: I _T		2			mA
RXD Output Current	Symbol: I _R				10	mA
Serial Interface	Standard CAN controller interface					
TRANSMISSION SPECIFICATIONS						
Data Delay	Symbol: t _T	TXD Transmit Delay		55	115	ns
	Symbol: t _R	RXD Receive Delay		65	135	
	Symbol: t _{PRO(TXD-RXD)}	Cycle Delay		120	250	
Dominant Timeout	Symbol: t _{to(dom)TXD}		0.3	1	12	ms
OUTPUT SPECIFICATIONS						
Dominant Level (Logic 0)	Symbol: V _{(OD)CANH}	CANH	2.75	3.5	4.5	VDC
	Symbol: V _{(OD)CANL}	CANL	0.5	1.5	2.25	
Recessive Level (Logic 1)	Symbol: V _{(OR)CANH}	CANH	2	2.5	3	VDC
	Symbol: V _{(OR)CANL}	CANL	2	2.5	3	
Differential Level	Symbol: V _{diff(d)}	Dominant Level (Logic 0)	1.5	2	3	VDC
	Symbol: V _{diff(r)}	Recessive Level (Logic 1)	-0.05	0	0.05	
Bus Pin Maximum Withstand Voltage	Symbol: V _X		-58		+58	VDC
Bus Transient Voltage	Symbol: V _{trt} , Meets ISO7637-3 standard		-150		+100	VDC
Bus Pin Leakage Current	Symbol: (VCC=0V, V _{CANH/L} =5V)		-5		5	uA
Differential Load Resistance	Symbol: R _L		45	60	65	Ω
Differential Input Impedance	Symbol: R _{diff}		19	30	52	kΩ
CAN Bus Interface	Meets ISO/DIS 11898 Standard Twisted-pair output					

SPECIFICATIONS

All specifications are based on 25°C, Humidity <75%, Nominal Input Voltage, and Rated Output Load unless otherwise noted.
We reserve the right to change specifications based on technological advances.

SPECIFICATION	TEST CONDITIONS	Min	Typ	Max	Unit
ENVIRONMENTAL SPECIFICATIONS					
Operating Temperature		-40		+105	°C
Transportation & Storage Temperature		-50		125	°C
Operating Humidity	Non-Condensing	10		90	%
Case Temperature Rise	Ta=25°C, Free Air Convection		25		°C
Pin Welding Resistance Temperature	Welding spot is 1.5mm away from the casing, 10 seconds			300	°C
Cooling Method		Free Air Convection			
GENERAL SPECIFICATIONS					
Isolation Voltage	Test for 1 minute, leakage current <1mA		2.5		kVDC
Insulation Resistance	Isolation Voltage 500VDC		100		MΩ
PHYSICAL SPECIFICATIONS					
Weight		0.07oz (2g) Typ.			
Dimensions (L x W x H)		0.50in x 0.40in x 0.30in (12.70mm x 10.16mm x 7.70mm)			
Case Material		Black Flame-Retardant & Heat-Resistant Plastic (UL94 V-0)			
SAFETY CHARACTERISTICS					
Safety Standard & Certification		EN60950			
Safety Class				Class III	
EMS	ESD	IEC/EN61000-4-2	Contact ±4kV/Air±8kV (Bare component, Signal Port)		Perf. Criteria A
	RS	IEC/EN61000-4-3	10V/m (Bare Component)		Perf. Criteria A
	EFT	IEC/EN61000-4-4	±2kV (Bare Component, Signal Port)		Perf. Criteria B
	Surge	IEC/EN61000-4-5	±2kV Line to Ground (Bare Component, Signal Port)		Perf. Criteria A
	CS	IEC/EN61000-4-6	3Vr.m.s. (Bare Component)		Perf. Criteria A

NOTES

- The presence of dust, fierce vibration, impulsion, and corrosive gas may cause damage to product.
- The performance indexes of the product models are as listed in the data sheet above, but some indexes of non-standard model products will exceed the above mentioned requirements. Contact factory for specific information.
- Customization available.

Application Precautions:

- Please read instructions carefully before use; call factory if you have questions.
- Do not use product in hazardous area
- This product is powered by DC power supply. AC power supply is prohibited.
- Do not dismount and assemble the product without permission to avoid failure or malfunction of equipment.
- Ex factory inspection and quality control have been strictly conducted for this product. If any abnormal operation or possibility of failure occurs in internal module, please contact factory for support.

*Due to advances in technology, specifications subject to change without notice.

MECHANICAL DRAWINGS

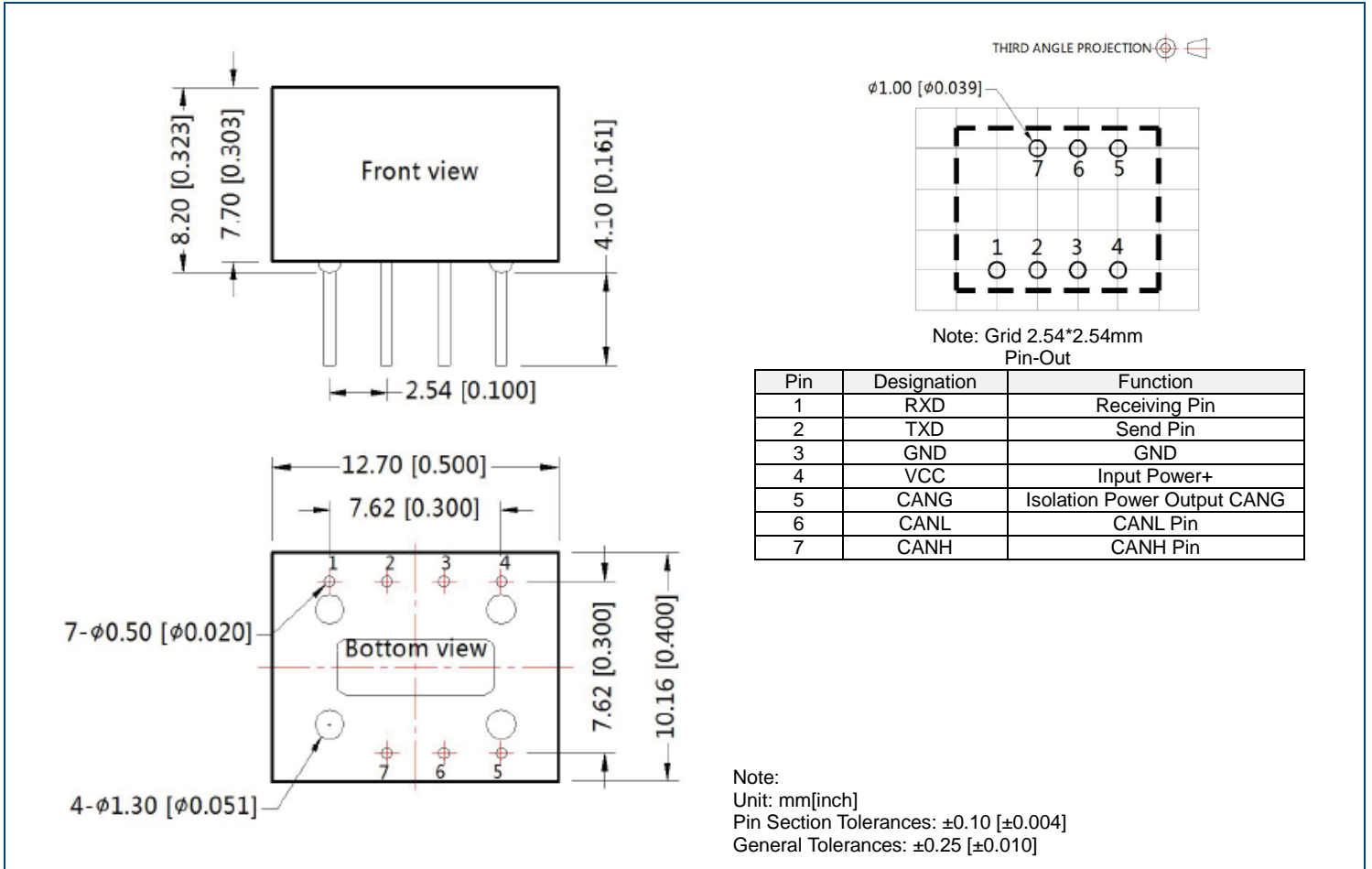

DESIGN REFERENCE

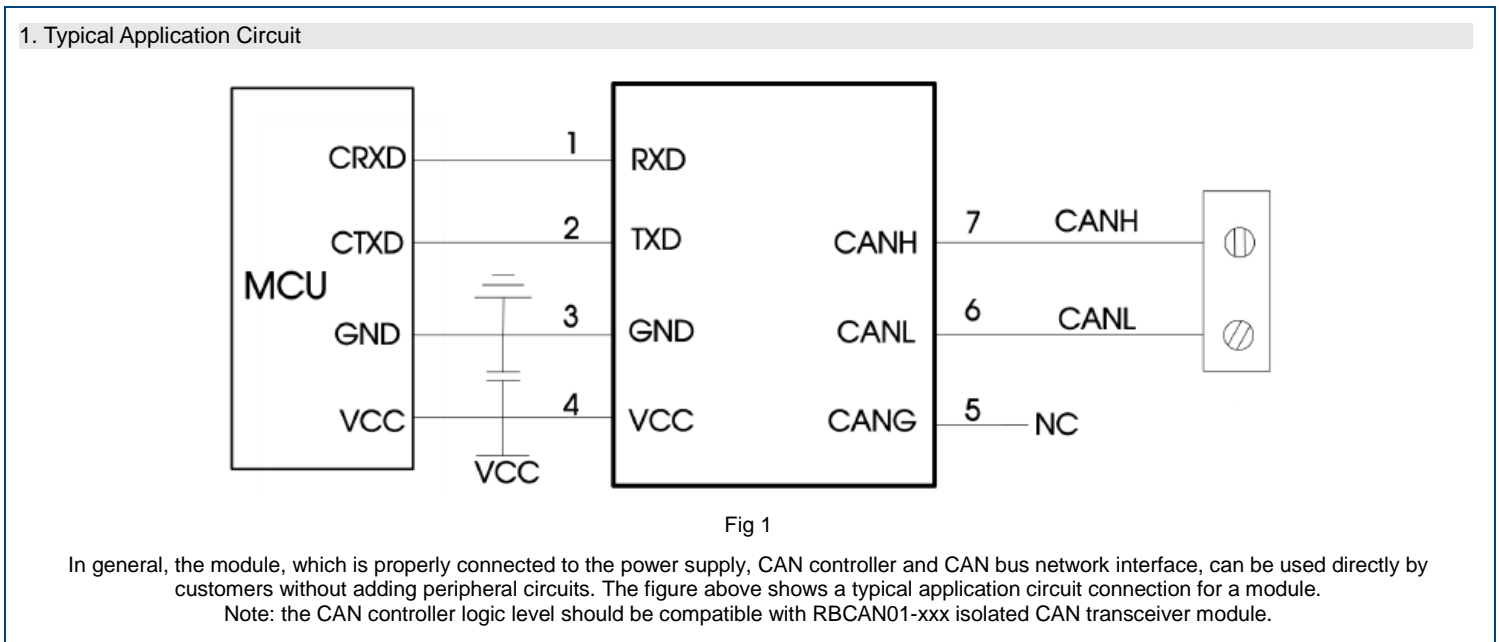

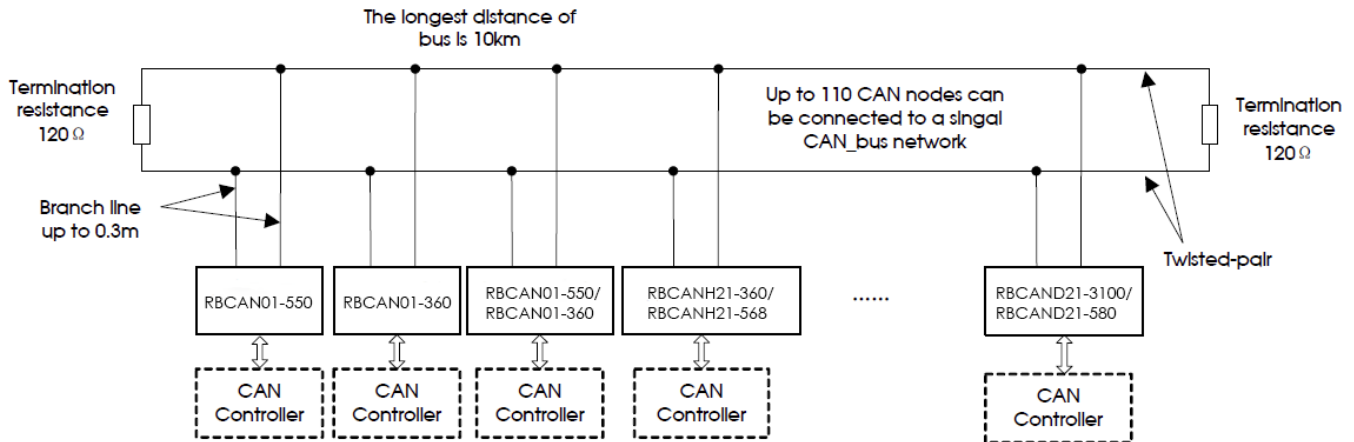

Fig 2

As shown in figure above, a single CAN-bus network can connect up to 110 single-channel RBCAN isolated CAN transceiver modules. The universal type module can support a max. communication distance of 10km while the high-speed type module can support a max communication distance of 1km with baud rate beyond 40kbps. If looking to access more nodes or longer communication distance, it can be achieved by using CAN repeaters or other expansion equipment.

Note: The communication distance of the bus is related to the communication speed and field application. It can be designed according to the actual application and reference standard. It is recommended that the communication cable is twisted pair or shielded twisted pair and should stay away from interference source. For long-distance communication, terminal resistance value needs to be selected according to the communication distance and cable impedance and number of nodes.

2. Recommended Port Protection Circuit

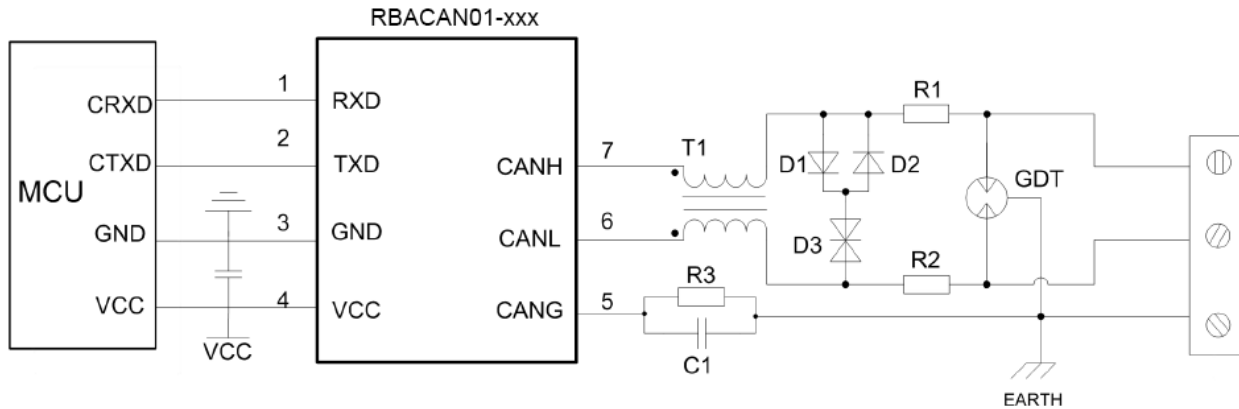

Fig 3

Note: Twisted pair shield grounded reliably.

Parameter declaration:

Components	Recommended Parameters	Components	Recommended Parameters
R3	1MΩ, 1206	R1,R2	2.7Ω/2W
C1	102,2kV	D1, D2	1N4007
T1	ACM2520-301-2P	D3	SMBJ15CA
GDT	B3D090L		

When the module is used in harsh field environment, it is susceptible to the large energy of a lightning strike. In this case, it is necessary to add protection circuit to the CAN signal port to protect the module from damage and ensure the reliability of bus communication. Figure 2 provides a recommended protection circuit design for high-energy lightning surges, with a degree of protection related to the selected protection device. Parameter description lists a set of recommended circuit parameters, which can be adjusted according to the actual application situation. Also, when using the shielded cable, the reliable single-point grounding of the shield must be achieved.

Note: This recommended parameter is only the recommended value, which is subject to the actual application. Recommended R1, R2, use PTC, D1, D2 use fast recovery diodes.

COMPANY INFORMATION

Wall Industries, Inc. has created custom and modified units for over 50 years. Our in-house research and development engineers will provide a solution that exceeds your performance requirements on-time and on budget. Our ISO9001-2008 certification is just one example of our commitment to producing a high quality, well-documented product for our customers.

Our past projects demonstrate our commitment to you, our customer. Wall Industries, Inc. has a reputation for working closely with its customers to ensure each solution meets or exceeds form, fit and function requirements. We will continue to provide ongoing support for your project above and beyond the design and production phases. Give us a call today to discuss your future projects.

Contact **Wall Industries** for further information:

Phone: ☎ (603)778-2300
Toll Free: ☎ (888)597-9255
Fax: ☎ (603)778-9797
E-mail: sales@wallindustries.com
Web: www.wallindustries.com
Address: 37 Industrial Drive
Exeter, NH 03833