

### GENERAL DESCRIPTION

The SGM3725 is a versatile constant current LED driver with a high efficiency step-up converter architecture. Unique technology and high 1.35A current limit allow SGM3725 to drive up to 38V output (10 LEDs in series). Alternatively, SGM3725 can deliver 260mA total current with 3 series LEDs per string. It can also maximize the current capability while achieving high conversion efficiency. The optimized 1.1MHz switching frequency results in reduced conduction loss and small external component size. A single wire interface is integrated to adjust the FB voltage in 32 steps, which can overcome audible noise and inrush current issues in normal PWM dimming schemes.

Various protection features are built into the SGM3725, including cycle-by-cycle input current limit protection, open LED (output over-voltage) protection and thermal shutdown protection. The leakage current in shutdown mode is less than 1 $\mu$ A.

The SGM3725 is available in Green TSOT-23-6 package. It operates over an ambient temperature range of -40°C to +85°C.

### FEATURES

- **Wide Output Range: Up to 10 Series LEDs**
- **Integrated 40V High Current Switch (1.35A Limit)**
- **2.7V to 5.5V Input Voltage Range**
- **High Efficiency PWM Converter**
- **Low 200mV Feedback Voltage**
- **500k $\Omega$  Pull-Down Resistor on CTRL Pin**
- **Single Wire Dimming Interface**
- **38V Open LED Protection**
- **1.1MHz Switching Frequency**
- **Integrated Soft-Start Function**
- **Less than 1 $\mu$ A Shutdown Current**
- **Simple, Small Solution Size**
- **Available in Green TSOT-23-6 Package**
- **-40°C to +85°C Operating Temperature Range**

### APPLICATIONS

LED Backlighting  
Mobile Phones  
Handheld Devices  
Digital Photo Frames  
Automotive Navigation

**PACKAGE/ORDERING INFORMATION**

MODEL	PACKAGE DESCRIPTION	SPECIFIED TEMPERATURE RANGE	ORDERING NUMBER	PACKAGE MARKING	PACKING OPTION
SGM3725	TSOT-23-6	-40°C to +85°C	SGM3725YTN6G/TR-V1	SK9XX	Tape and Reel, 3000

NOTE: XX = Date Code.

**Green (RoHS & HSF):** SG Micro Corp defines "Green" to mean Pb-Free (RoHS compatible) and free of halogen substances. If you have additional comments or questions, please contact your SGMICRO representative directly.

**ABSOLUTE MAXIMUM RATINGS**

Input Voltage,  $V_{IN}$ ..... -0.3V to 6V  
 High Voltage Nodes, SW, VOUT ..... -0.3V to 40V  
 Other Pins, FB, CTRL.....-0.3V to  $V_{IN} + 0.3V$   
 Package Thermal Resistance  
 TSOT-23-6,  $\theta_{JA}$  ..... 120°C/W  
 Junction Temperature .....+150°C  
 Storage Temperature Range .....-65°C to +150°C  
 Lead Temperature (Soldering, 10sec) .....+260°C  
 ESD Susceptibility  
 HBM..... 4000V  
 MM..... 200V

**RECOMMENDED OPERATING CONDITIONS**

Input Voltage Range .....2.7V to 5.5V  
 Operating Temperature Range .....-40°C to +85°C

**MARKING INFORMATION**

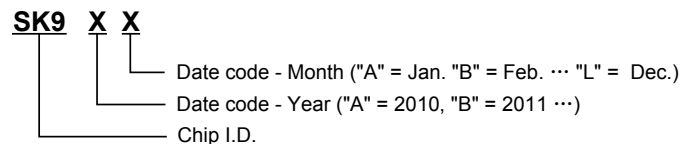

For example: SK9FA (2015, January)

**OVERSTRESS CAUTION**

Stresses beyond those listed may cause permanent damage to the device. Functional operation of the device at these or any other conditions beyond those indicated in the operational section of the specification is not implied. Exposure to absolute maximum rating conditions for extended periods may affect reliability.

**ESD SENSITIVITY CAUTION**

This integrated circuit can be damaged by ESD if you don't pay attention to ESD protection. SGMICRO recommends that all integrated circuits be handled with appropriate precautions. Failure to observe proper handling and installation procedures can cause damage. ESD damage can range from subtle performance degradation to complete device failure. Precision integrated circuits may be more susceptible to damage because very small parametric changes could cause the device not to meet its published specifications.

**DISCLAIMER**

SG Micro Corp reserves the right to make any change in circuit design, specification or other related things if necessary without notice at any time.

**PIN CONFIGURATION**

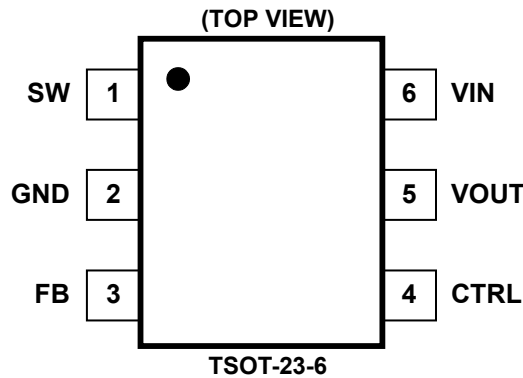

**PIN DESCRIPTION**

PIN	NAME	FUNCTION
1	SW	Converter Switching Node.
2	GND	Ground.
3	FB	Output Feedback Pin Regulated at 200mV.
4	CTRL	Control Pin of the Boost Regulator. Can be used to enable/disable the IC, as well as to program the output current at 32 levels.
5	VOUT	Output and Over-Voltage Protection Pin.
6	VIN	IC Supply. Connect VIN to a supply voltage between 2.7V and 5.5V.

**TYPICAL APPLICATION**

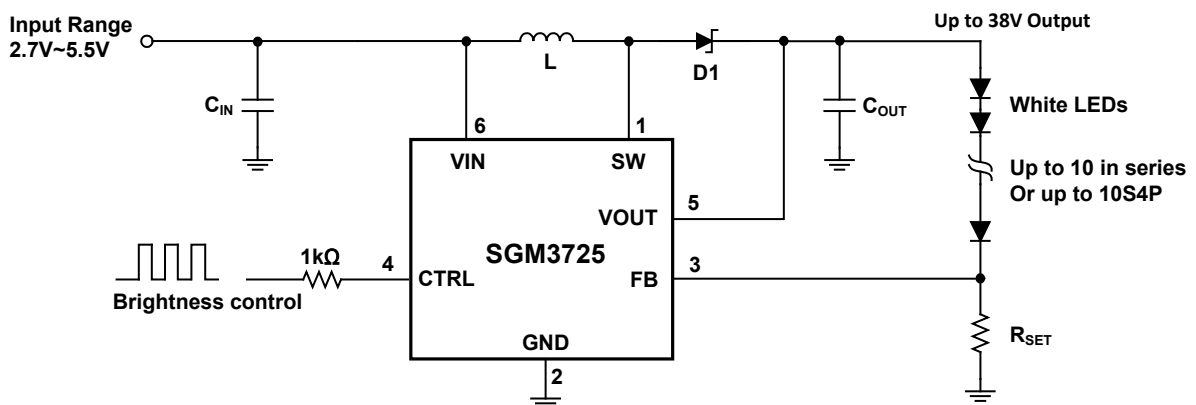

Figure 1. Typical Application Circuit

**ELECTRICAL CHARACTERISTICS** <sup>(1)</sup>

( $V_{IN} = 3.6V$ ,  $L = 10\mu H$ ,  $C_{IN} = 10\mu F$ ,  $C_{OUT} = 0.47\mu F$ , Full =  $-40^{\circ}C$  to  $+85^{\circ}C$ , typical values are at  $T_A = +25^{\circ}C$ , unless otherwise noted.)

PARAMETER	SYMBOL	CONDITIONS	TEMP	MIN	TYP	MAX	UNITS
<b>IC SUPPLY</b>							
Input Voltage Range	$V_{IN}$		Full	2.7		5.5	V
Input Under-Voltage Lockout	UVLO	Rising edge	$+25^{\circ}C$		2.5	2.6	V
UVLO Hysteresis	$V_{HYS}$		$+25^{\circ}C$		0.15		V
Quiescent Current (Non Switching)	$I_Q$	$V_{FB} = 0.4V$	$+25^{\circ}C$		0.20	0.35	mA
Operating Current (Switching)		$V_{FB} = 0V$	$+25^{\circ}C$		0.72	1.5	mA
VIN Pin Shutdown Current	$I_{SHDN}$	$V_{EN} = 0V$	$+25^{\circ}C$		0.1	1	$\mu A$
<b>STEP-UP CONVERTER</b>							
Voltage Feedback Regulation Voltage	$V_{REF}$		Full	192	200	212.5	mV
Voltage Feedback Input Bias Current	$I_{FB}$		Full		0.001	0.3	$\mu A$
SW Pin Leakage Current	$I_{SW}$		$+25^{\circ}C$		0.01	1	$\mu A$
Peak NMOS Current Limit	$I_{LIM}$		$+25^{\circ}C$		1.35		A
Oscillator Frequency	$f_S$		Full	0.90	1.10	1.4	MHz
Over-Voltage Threshold	$V_{OVP}$	Measured at VOUT pin	Full	35.5	38.0	40.5	V
Start-Up Time	$t_S$		$+25^{\circ}C$		800		$\mu s$
<b>CONTROL</b>							
Logic Low Threshold	$V_{IL}$		Full			0.35	V
Logic High Threshold	$V_{IH}$		Full	1.5			V
Minimum Logic High Pulse Width Timing	$t_{HIGH\_MIN}$		$+25^{\circ}C$	0.4			$\mu s$
Logic Low Pulse Width Timing	$t_{LOW}$		$+25^{\circ}C$	0.4		750	$\mu s$
Minimum Shutdown Pulse Width Timing	$t_{OFF}$		$+25^{\circ}C$	3			ms
Junction Thermal Shutdown Threshold					150		$^{\circ}C$
Junction Thermal Shutdown Hysteresis					15		$^{\circ}C$

## NOTE:

1. The SGM3725 is guaranteed to meet performance specifications over the  $-40^{\circ}C$  to  $+85^{\circ}C$  operating temperature range by design, characterization and correlation with statistical process controls.

RECOMMENDED COMPONENTS OF TEST CIRCUITS

	COMPONENT		COMPONENT
INDUCTOR	22μH/CD75NP-220KC	CAPACITOR	10μF/C2012X7R1H106KT
	10μH/CD75NP-100KC		0.47μF/C2012X7R1H474KT
DIODE	MBR0540		

TYPICAL PERFORMANCE CHARACTERISTICS

T<sub>A</sub> = +25°C, L = 10μH, C<sub>IN</sub> = 10μF, C<sub>OUT</sub> = 0.47μF, unless otherwise noted.

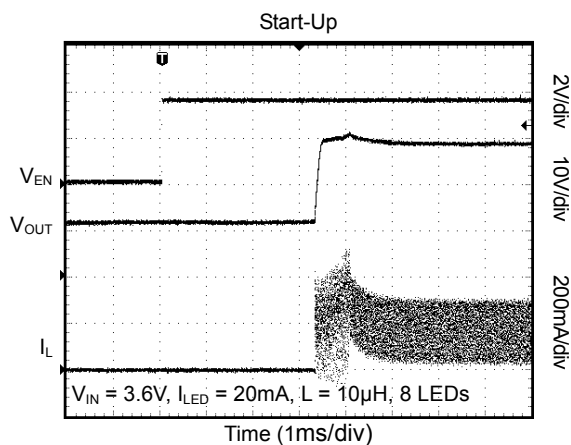
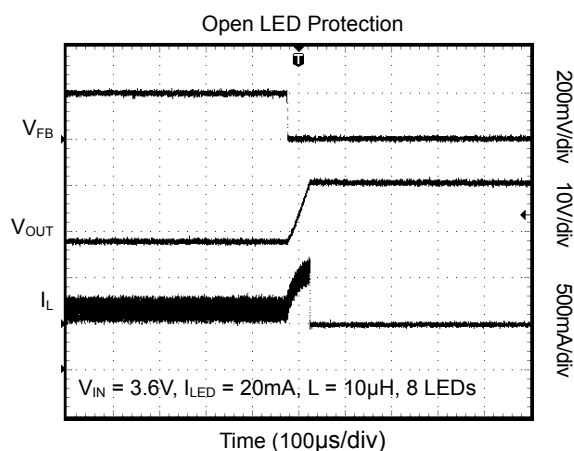
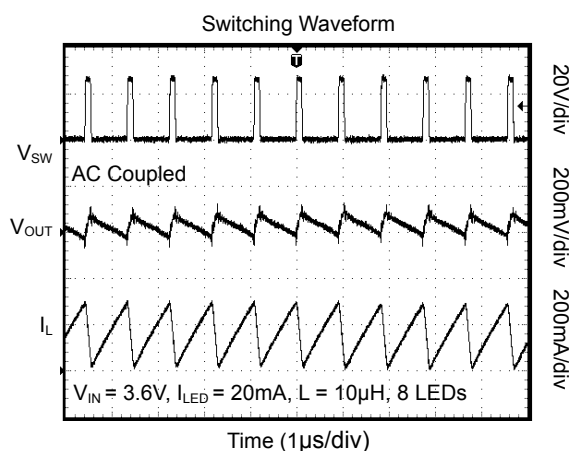

TYPICAL PERFORMANCE CHARACTERISTICS

T<sub>A</sub> = +25°C, L = 10µH, C<sub>IN</sub> = 10µF, C<sub>OUT</sub> = 0.47µF, unless otherwise noted.

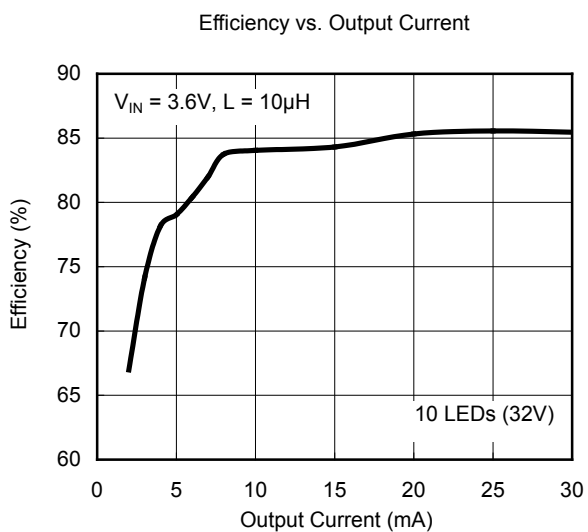
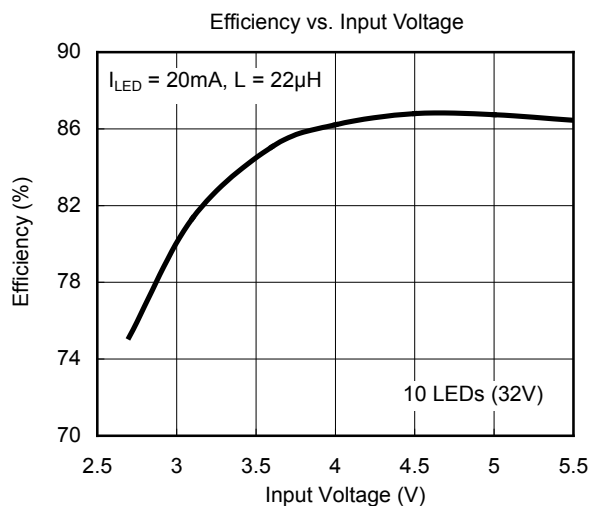
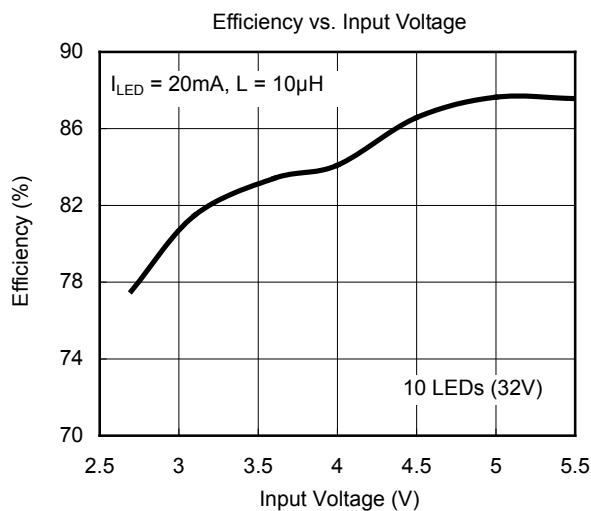
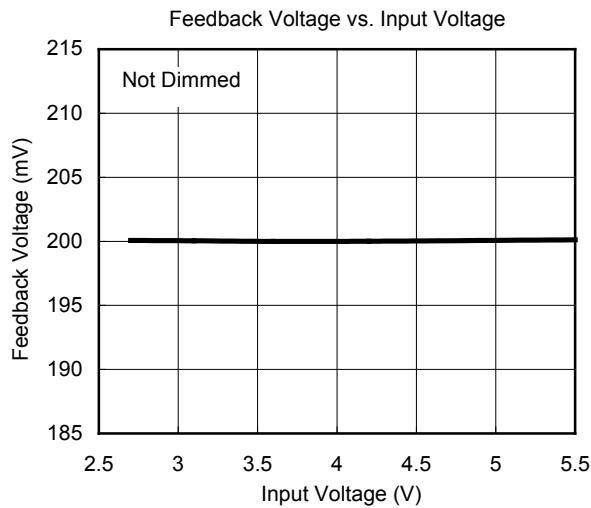
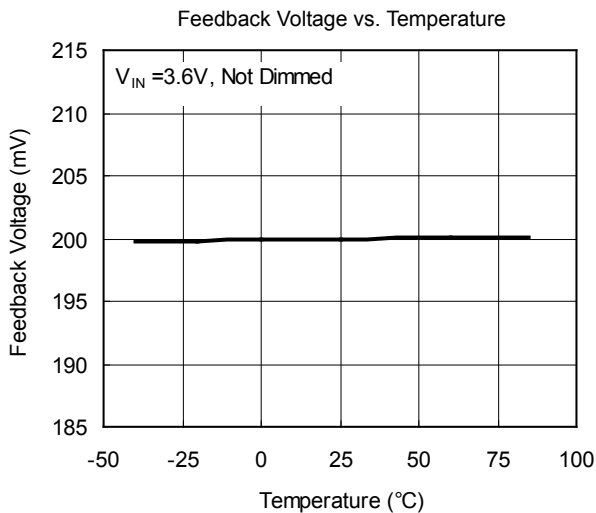

FUNCTIONAL BLOCK DIAGRAM

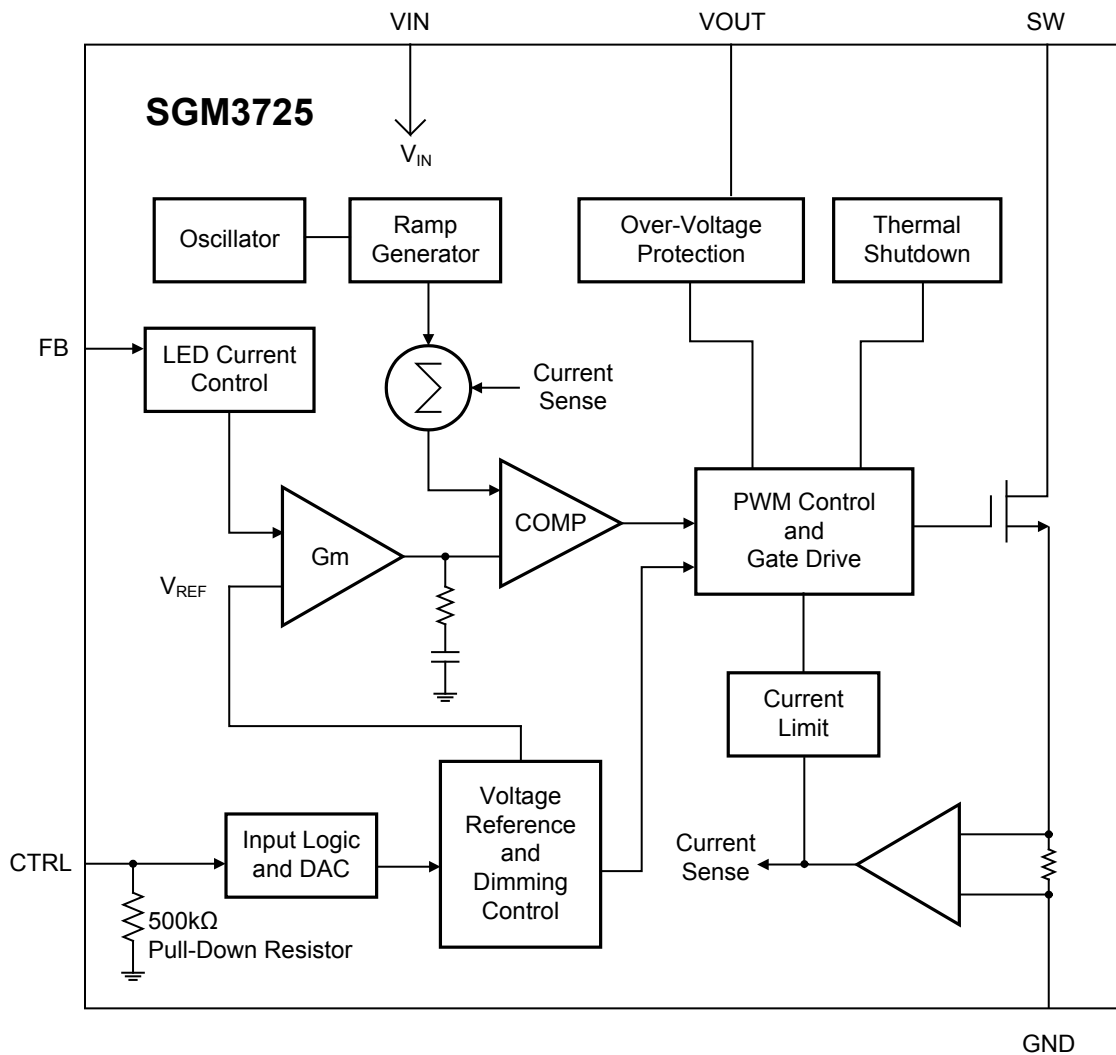

Figure 2. SGM3725 Block Diagram

## FUNCTIONAL DESCRIPTION

The SGM3725 uses a constant-frequency current-mode boost converter architecture to control the LED current by regulating the feedback voltage. Please refer to the FUNCTIONAL BLOCK DIAGRAM above for an explanation of SGM3725 operation. The beginning of each cycle turns on the Power MOSFET. A slope compensation ramp is added to the output of the current sense amplifier and the result is fed into the positive input of the comparator (COMP). When this voltage goes above the output voltage of the error amplifier (Gm), the Power MOSFET is turned off. The voltage at the output of the Gm block amplifies the difference between the reference voltage and the feedback voltage (FB), so that FB voltage can be regulated to the reference voltage.

The SGM3725 has built-in soft-start to limit the inrush current during start-up and to limit the amount of overshoot on the output. Protection features in the SGM3725 include over-voltage protection (OVP), cycle-by-cycle current limit protection and thermal shutdown. OVP protects in the event where an LED fails open, which forces the feedback voltage to zero. This causes the boost converter to operate in maximum duty cycle mode, ramping up the output voltage. Switching will stop when the output reaches the OVP threshold. The OVP feature protects the IC from damaging itself by exceeding the voltage rating on SW/VOUT pins.

The single wire control interface accepts a series of pulses into the CTRL pin to program the reference voltage. The number of rising edges is detected internally and decoded as illustrated in Table 1. The register contains 5-bits, yielding 32 different current levels. Using the simplest control method, output current can be toggled on and off between  $I_{MAX}$  and 0mA, by pulling the CTRL pin high or low.  $I_{MAX}$  is programmed by the resistor connected between FB and GND. Please see LED Maximum Current Setting section in this document to determine the proper resistor value. The next level of control is achieved by injecting a series of pulses into the CTRL pin to program the reference voltage at 32 levels. The number of rising edges is detected internally and decoded to the current level as illustrated in Table 1. The reference voltage levels are evenly spaced among these 32 steps.

The first rising edge on the CTRL pin takes the current level to maximum of 100% of  $I_{MAX}$ . Then the current will be changed with each additional qualified pulse. The current stays unchanged as long as the CTRL pin stays high.

Table 1. Current Setting

DATA	LED Current Ratio	DATA	LED Current Ratio	DATA	LED Current Ratio	DATA	LED Current Ratio
1	32/32	9	24/32	17	16/32	25	8/32
2	31/32	10	23/32	18	15/32	26	7/32
3	30/32	11	22/32	19	14/32	27	6/32
4	29/32	12	21/32	20	13/32	28	5/32
5	28/32	13	20/32	21	12/32	29	4/32
6	27/32	14	19/32	22	11/32	30	3/32
7	26/32	15	18/32	23	10/32	31	2/32
8	25/32	16	17/32	24	9/32	32	1/32

## APPLICATION INFORMATION

### Inductor Selection

A 6.8µH to 22µH inductor is recommended for 10/8/6 series LED applications and 10S4P LED applications. If high efficiency is a critical requirement, a low DCR inductor should be selected. The inductor’s saturation current rating should also exceed the peak input current, especially for high load current application (like 10S4P).

### Capacitor Selection

Small size ceramic capacitors are ideal for SGM3725 application. An input capacitor in the range of 1µF to 22µF and a 0.47µF output capacitor are suggested for 10/8/6 series LED applications. For higher output current applications like 10S4P, larger value output capacitors like 2.2µF are recommended to minimize output ripple.

### Diode Selection

The current rating of the Schottky diode should exceed the peak current of the boost converter. The voltage rating should also exceed the target output voltage.

### LED Maximum Current Setting

LED maximum current setting,  $I_{MAX}$ , is determined by the feedback resistor ( $R_{SET}$  in Figure 3). The feedback voltage is internally set at 200mV when the DATA = 1. The LED current is programmed according to the formula  $I_{MAX} = 200mV/R_{SET}$ . For accurate LED current settings, precision 1% resistors are recommended. The formula and table for  $R_{SET}$  selection are shown below.

$$R_{SET} = 200mV/I_{MAX}$$

Table 2. Current Setting Resistor

$R_{SET}$ (Ω)	$I_{MAX}$ Current (mA)
200	1
40.2	5
20.0	10
13.3	15
10.0	20
6.65	30
2.00	100

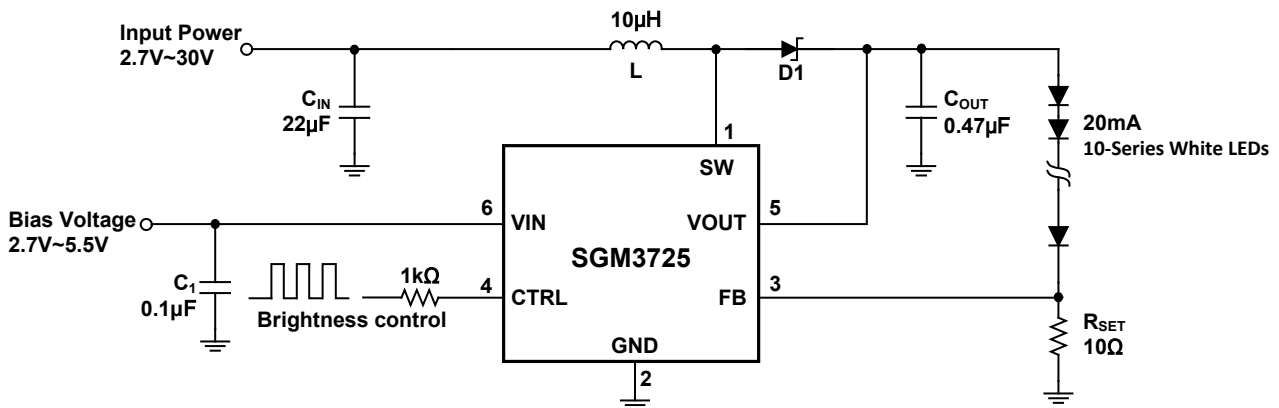

Figure 3. Application Circuit for 10 LEDs in Series with 20mA Current (VIN can be tied to input power rail if less than 5.5V)

## APPLICATION INFORMATION

### Current Setting at CTRL Pin

Current control can be as simple as a bi-level signal at the CTRL pin, resulting in LEDs ON at 100%  $I_{MAX}$  or LED OFF state. However, more sophisticated control techniques can be achieved by pulsing the CTRL pin. An example for programming the output current is shown in Figure 4.

There are two ways to adjust the channels' ON/OFF state or current level. The first way is by simply adding the number of pulses according to Table 2. For example, we will use  $R_{SET} = 10\Omega$  to program 20mA  $I_{MAX}$ . In this example, the user can add 12 more pulses when changing from 14/32 (8.75mA when  $I_{MAX} = 20mA$ ) to 2/32 (1.25mA when  $I_{MAX} = 20mA$ ). However, increasing the current level can be accomplished by two ways, allowing for more flexible programming.

Since the data in Table 1 automatically circles around after 32 pulses, adding 32-8 = 24 pulses changes from 6/32 (DATA 27) to 14/32 (DATA 19). The second way is to reset the IC by pulling CTRL pin low for 3ms (guaranteed shutdown), and then inputting the desired number of pulses.

Example: going from 6/32 (DATA 27) to 14/32 (DATA 19)

- Option 1: send in 24 pulses ( $19+32-27 = 24$ );
- Option 2: pull low for 3ms and then send in 19 pulses.

### Layout Considerations

PCB layout is very important for high frequency switching regulators in order to keep the loop stable and minimize noise. The input capacitor should be very close to the IC to get the best decoupling. The path of the inductor and output capacitor should be kept as short as possible to minimize noise and ringing. Please see the SGM3725 evaluation document for detailed PCB layout guidelines.

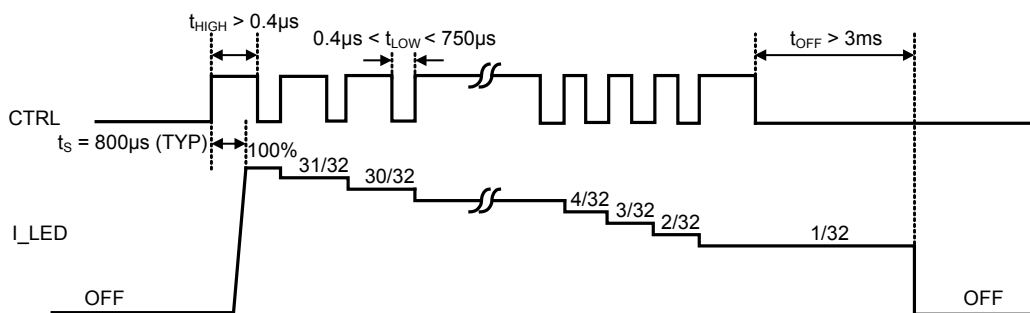
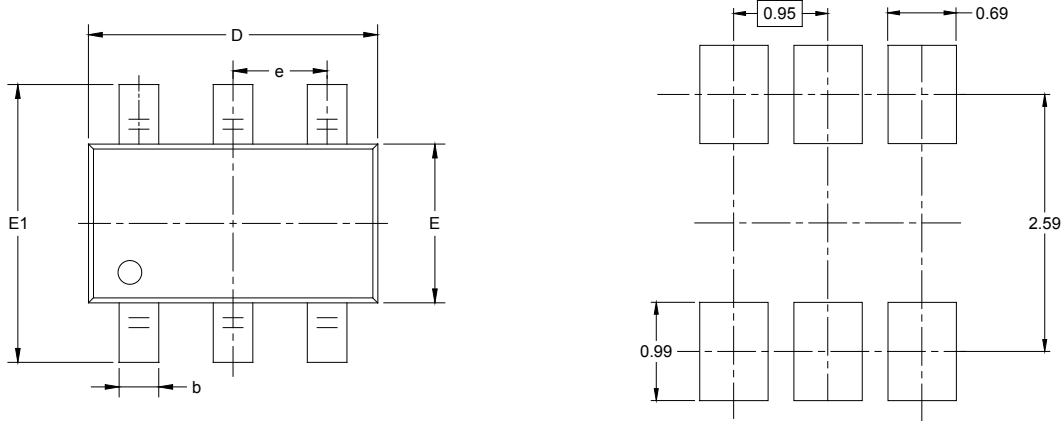

Figure 4. Output Current Programming via CTRL Pin

PACKAGE OUTLINE DIMENSIONS

TSOT-23-6



RECOMMENDED LAND PATTERN (Unit: mm)

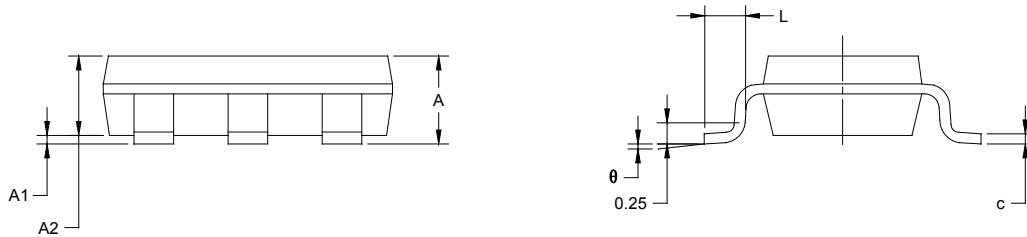

Symbol	Dimensions In Millimeters		Dimensions In Inches	
	MIN	MAX	MIN	MAX
A		1.000		0.043
A1	0.000	0.100	0.000	0.004
A2	0.700	0.900	0.028	0.039
b	0.300	0.500	0.012	0.020
c	0.080	0.200	0.003	0.008
D	2.850	2.950	0.112	0.116
E	1.550	1.650	0.061	0.065
E1	2.650	2.950	0.104	0.116
e	0.950 BSC		0.037 BSC	
L	0.300	0.600	0.012	0.024
θ	0°	8°	0°	8°

# PACKAGE INFORMATION

## TAPE AND REEL INFORMATION

### REEL DIMENSIONS

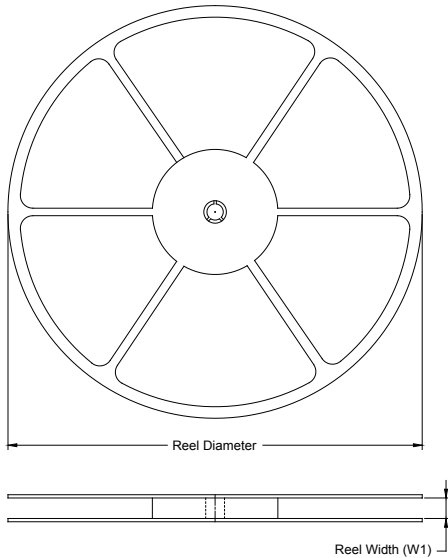

### TAPE DIMENSIONS

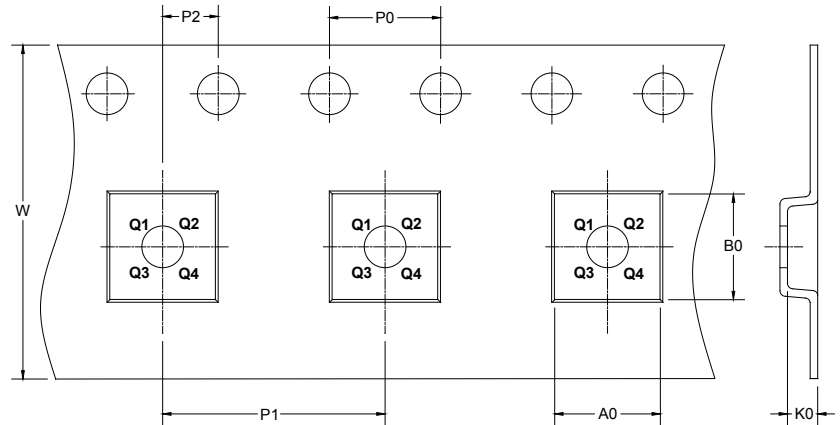

➔ DIRECTION OF FEED

NOTE: The picture is only for reference. Please make the object as the standard.

### KEY PARAMETER LIST OF TAPE AND REEL

Package Type	Reel Diameter	Reel Width W1 (mm)	A0 (mm)	B0 (mm)	K0 (mm)	P0 (mm)	P1 (mm)	P2 (mm)	W (mm)	Pin1 Quadrant
TSOT-23-6	7"	9.5	3.2	3.1	1.1	4.0	4.0	2.0	8.0	Q3

000001

# PACKAGE INFORMATION

## CARTON BOX DIMENSIONS

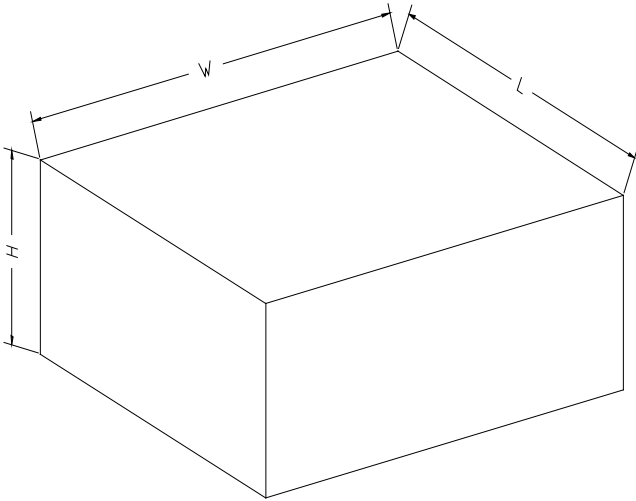

NOTE: The picture is only for reference. Please make the object as the standard.

## KEY PARAMETER LIST OF CARTON BOX

Reel Type	Length (mm)	Width (mm)	Height (mm)	Pizza/Carton
7" (Option)	368	227	224	8
7"	442	410	224	18

DD0002