

# Test disconnect terminal block - UTME 4-P/P BU - 3047454

Please be informed that the data shown in this PDF Document is generated from our Online Catalog. Please find the complete data in the user's documentation. Our General Terms of Use for Downloads are valid (<http://phoenixcontact.com/download>)



Test disconnect terminal block, With test socket screws for insertion of test plugs, nom. voltage: 500 V, nominal current: 28 A, connection method: Screw connection, number of connections: 2, cross section: 0.14 mm<sup>2</sup> - 6 mm<sup>2</sup>, AWG: 26 - 10, width: 6.2 mm, color: blue, mounting type: NS 35/7,5, NS 35/15

## Your advantages

- Compact design



## Key Commercial Data

Packing unit	50 pc
GTIN	
GTIN	4046356701716

## Technical data

### General

Number of levels	1
Number of connections	2
Nominal cross section	4 mm <sup>2</sup>
Color	blue
Insulating material	PA
Flammability rating according to UL 94	V0
Rated surge voltage	6 kV
Overvoltage category	III
Insulating material group	I
Maximum power dissipation for nominal condition	1.02 W
Connection in acc. with standard	IEC 60947-7-1
Nominal current I <sub>N</sub>	28 A
Maximum load current	28 A
Nominal voltage U <sub>N</sub>	500 V
Open side panel	Yes

# Test disconnect terminal block - UTME 4-P/P BU - 3047454

## Technical data

### General

Relative insulation material temperature index (Elec., UL 746 B)	130 °C
Temperature index of insulation material (DIN EN 60216-1 (VDE 0304-21))	130 °C
Static insulating material application in cold	-60 °C
Behavior in fire for rail vehicles (DIN 5510-2)	Test passed
Flame test method (DIN EN 60695-11-10)	V0
Oxygen index (DIN EN ISO 4589-2)	>32 %
NF F16-101, NF F10-102 Class I	2
NF F16-101, NF F10-102 Class F	2
Surface flammability NFPA 130 (ASTM E 162)	passed
Specific optical density of smoke NFPA 130 (ASTM E 662)	passed
Smoke gas toxicity NFPA 130 (SMP 800C)	passed
Calorimetric heat release NFPA 130 (ASTM E 1354)	28 MJ/kg
Fire protection for rail vehicles (DIN EN 45545-2) R22	HL 1 - HL 3
Fire protection for rail vehicles (DIN EN 45545-2) R23	HL 1 - HL 3
	HL 1 - HL 3
Fire protection for rail vehicles (DIN EN 45545-2) R26	HL 1 - HL 3

### Dimensions

Length	66 mm
Width	6.2 mm
Height NS 35/7,5	49.5 mm
Height NS 35/15	57 mm

### Connection data

Conductor cross section solid min.	0.14 mm <sup>2</sup>
Conductor cross section solid max.	6 mm <sup>2</sup>
Conductor cross section flexible min.	0.14 mm <sup>2</sup>
Conductor cross section flexible max.	6 mm <sup>2</sup>
Conductor cross section AWG min.	26
Conductor cross section AWG max.	10
Conductor cross section flexible, with ferrule without plastic sleeve min.	0.14 mm <sup>2</sup>
Conductor cross section flexible, with ferrule without plastic sleeve max.	4 mm <sup>2</sup>
Conductor cross section flexible, with ferrule with plastic sleeve min.	0.14 mm <sup>2</sup>
Conductor cross section flexible, with ferrule with plastic sleeve max.	4 mm <sup>2</sup>
2 conductors with same cross section, solid min.	0.14 mm <sup>2</sup>
2 conductors with same cross section, solid max.	1.5 mm <sup>2</sup>
2 conductors with same cross section, stranded min.	0.14 mm <sup>2</sup>
2 conductors with same cross section, stranded max.	1.5 mm <sup>2</sup>
2 conductors with same cross section, stranded, ferrules without plastic sleeve, min.	0.14 mm <sup>2</sup>
2 conductors with same cross section, stranded, ferrules without plastic sleeve, max.	1.5 mm <sup>2</sup>

# Test disconnect terminal block - UTME 4-P/P BU - 3047454

## Technical data

### Connection data

2 conductors with same cross section, stranded, TWIN ferrules with plastic sleeve, min.	0.5 mm <sup>2</sup>
2 conductors with same cross section, stranded, TWIN ferrules with plastic sleeve, max.	2.5 mm <sup>2</sup>
Connection method	Screw connection
Stripping length	9 mm
Internal cylindrical gage	A4
Screw thread	M3
Tightening torque, min	0.6 Nm
Tightening torque max	0.8 Nm

### Standards and Regulations

Connection in acc. with standard	IEC 60947-7-1
Flammability rating according to UL 94	V0
Fire protection for rail vehicles (DIN EN 45545-2) R22	HL 1 - HL 3
Fire protection for rail vehicles (DIN EN 45545-2) R23	HL 1 - HL 3
Fire protection for rail vehicles (DIN EN 45545-2) R24	HL 1 - HL 3
Fire protection for rail vehicles (DIN EN 45545-2) R26	HL 1 - HL 3

### Environmental Product Compliance

	Lead 7439-92-1
China RoHS	Environmentally Friendly Use Period = 50
	For details about hazardous substances go to tab "Downloads", Category "Manufacturer's declaration"

## Drawings

Circuit diagram



# Test disconnect terminal block - UTME 4-P/P BU - 3047454

Circuit diagram

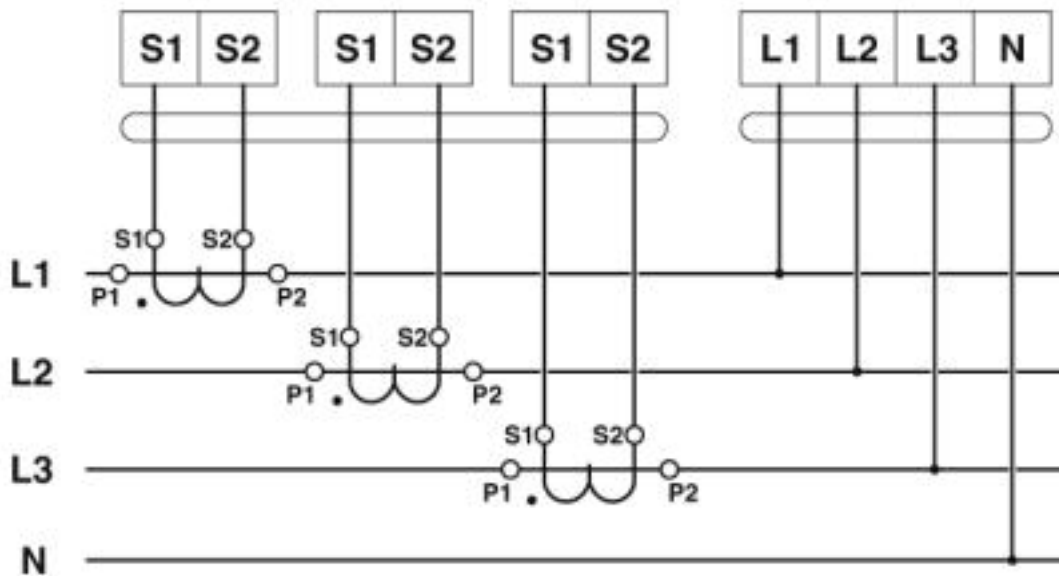

Circuit diagram

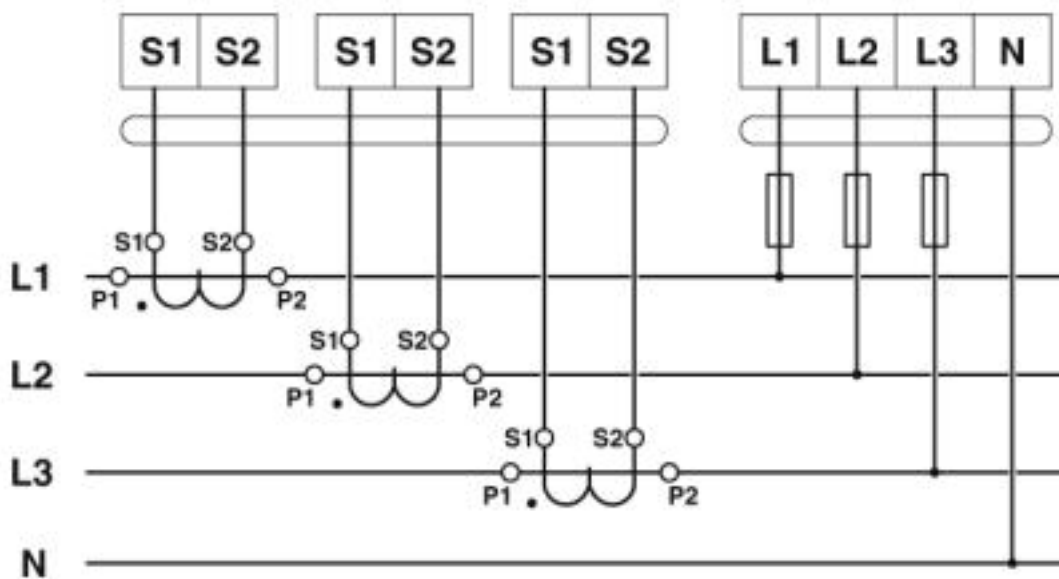

Approvals

Approvals

Approvals

CSA / UL Recognized / cUL Recognized / EAC / EAC / cULus Recognized

# Test disconnect terminal block - UTME 4-P/P BU - 3047454

## Approvals

Ex Approvals

### Approval details

CSA		<a href="http://www.csagroup.org/services-industries/product-listing/">http://www.csagroup.org/services-industries/product-listing/</a>	13631
	B	C	D
Nominal voltage UN	300 V	300 V	600 V
Nominal current IN	25 A	25 A	5 A
mm <sup>2</sup> /AWG/kcmil	26-10	26-10	26-10

UL Recognized		<a href="http://database.ul.com/cgi-bin/XYV/template/LISEXT/1FRAME/index.htm">http://database.ul.com/cgi-bin/XYV/template/LISEXT/1FRAME/index.htm</a>	FILE E 60425
	B	C	D
Nominal voltage UN	300 V	300 V	600 V
Nominal current IN	25 A	25 A	5 A
mm <sup>2</sup> /AWG/kcmil	26-10	26-10	26-10

cUL Recognized		<a href="http://database.ul.com/cgi-bin/XYV/template/LISEXT/1FRAME/index.htm">http://database.ul.com/cgi-bin/XYV/template/LISEXT/1FRAME/index.htm</a>	FILE E 60425
	B	C	D
Nominal voltage UN	300 V	300 V	600 V
Nominal current IN	25 A	25 A	5 A
mm <sup>2</sup> /AWG/kcmil	26-10	26-10	26-10

EAC		EAC-Zulassung
-----	--	---------------

EAC		RU C- DE.A*30.B.01742
-----	--	--------------------------

cULus Recognized	
------------------	--

Phoenix Contact 2019 © - all rights reserved  
<http://www.phoenixcontact.com>

PHOENIX CONTACT GmbH & Co. KG  
Flachmarktstr. 8  
32825 Blomberg  
Germany  
Tel. +49 5235 300  
Fax +49 5235 3 41200  
<http://www.phoenixcontact.com>