

EVERPURE® HFC-10 SYSTEM

DELIMING SYSTEM FOR WAREWASHING EQUIPMENT

HFC-10 Deliming System: EV9100-91

HT-10 Replacement Cartridge: EV9799-22



APPLICATIONS

Commercial dishwashers
Commercial glassware washers
Warewashing booster heaters

FEATURES • BENEFITS

Uses ScaleKleen, Everpure's proprietary food-grade scale remover which is environmentally safe

System includes; a heavy-duty housing, dip tube assembly, 2.2 lb. ScaleKleen package and hardness test strip

Provides simple, efficient delimiting of commercial warewashing equipment

Reduces limescale deposits which can cause equipment failure

Improves equipment efficiency, helps extend the life of equipment and reduces maintenance costs

INSTALLATION TIPS

System must be installed on inlet water line to equipment

Installing a bypass for delimiting is recommended

Use 1/2" water line

Install vertically using the mounting bracket provided

OPERATION TIPS

Follow delimiting schedule as noted in operation manual

To determine water hardness and frequency of delimiting, follow instructions on hardness test strip package and compare to hours of operation

SIZING

Service Flow Rate: Maximum 6 gpm (22.7 Lpm)

EVERPURE® HFC-10 SYSTEM

EV9100-91

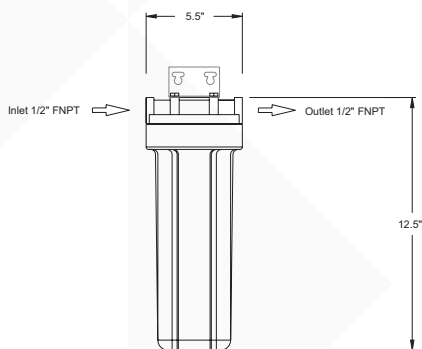

SPECIFICATIONS

Overall Dimensions

12.5" L x 5.5" dia. (31.8 x 13.9 cm)

Inlet Connection 1/2"

Outlet Connection 1/2"

Service Flow Rate

Maximum 6 gpm (22.7 Lpm)

Pressure Requirements

10 – 125 psi (0.7 – 8.6 bar), non-shock

Temperature

160°F (94°C)

Operating Weight

10 lbs (4.5 kg)

Shipping Weight

7 lbs (3.1 kg)

Electrical Connection

None required

The contaminants or other substances removed or reduced by this drinking water system are not necessarily in your water. Do not use with water that is microbiologically unsafe or of unknown quality without adequate disinfection before or after the system.

WARRANTY

Everpure water treatment systems by Pentair® (excluding replaceable elements) are covered by a limited warranty against defects in material and workmanship for a period of five years after date of purchase. Everpure replaceable elements (filter cartridges and water treatment cartridges) are covered by a limited warranty against defects in material and workmanship for a period of one year after date of purchase. See printed warranty for details. Pentair will provide a copy of the warranty upon request.



FILTRATION & PROCESSING SOLUTIONS

EVERPURE-SHURFLO WORLD HEADQUARTERS, 1040 MUIRFIELD DRIVE, HANOVER PARK, IL 60133 USA • WWW.EVERPURE.COM
800.942.1153 MAIN (US ONLY) • 630.307.3000 MAIN • 630.307.3030 FAX • CSEVERPURE@PENTAIR.COM EMAIL

EVERPURE-SHURFLO AUSTRALIA / NEW ZEALAND, 1-21 MONASH DRIVE, DANDENONG SOUTH, VIC, 3175, AUSTRALIA
1300.576.190 TEL • AU.EVERPURE@PENTAIR.COM EMAIL

EVERPURE-SHURFLO CHINA, 21F CLOUD 9 PLAZA, NO 1118, SHANGHAI, 200052, CHINA
86.21.3211.4588 TEL • 86.21.3211.4580 FAX • CHINA.WATER@PENTAIR.COM EMAIL

EVERPURE-SHURFLO INDIA, GREEN BOULEVARD, B-9/A, 7TH FLOOR - TOWER B SECTOR 62, NOIDA - 201301
91.120.419.9444 TEL • 91.120.419.9400 FAX • INDIACUSTOMER@PENTAIR.COM EMAIL

EVERPURE-SHURFLO EUROPE, PENTAIR WATER BELGIUM BVBA, INDUSTRIEPARK WOLFSTEE, TOEKOMSTLAAN, 30 B-2200 HERENTALS, BELGIUM
+32.(0).14.283.500 TEL • +32.(0).14.283.505 FAX • SALES@EVERPURE-EUROPE.COM EMAIL

EVERPURE-SHURFLO JAPAN INC., HASHIMOTO MN BLDG. 7F, 3-25-1 HASHIMOTO, MIDORI-KU, SAGAMIHARA-SHI KANAGAWA 252-0143, JAPAN
81.(0)42.775.3011 TEL • 81.(0)42.775.3015 FAX • INFO@EVERPURE.CO.JP EMAIL

EVERPURE-SHURFLO SOUTHEAST ASIA, 390 HAVELOCK ROAD, #04-01, KING'S CENTRE, SINGAPORE 169662
65.6795.2213 TEL • FAX: 65.6795.2219 FAX • CSEVERPURE@PENTAIR.COM EMAIL

All Pentair trademarks and logos are owned by Pentair, Inc. All other brand or product names are trademarks or registered marks of their respective owners. Because we are continuously improving our products and services, Pentair reserves the right to change specifications without prior notice. Pentair is an equal opportunity employer.