

RPC-1.85

Mismatch  
Jack

**08S150-055S3**

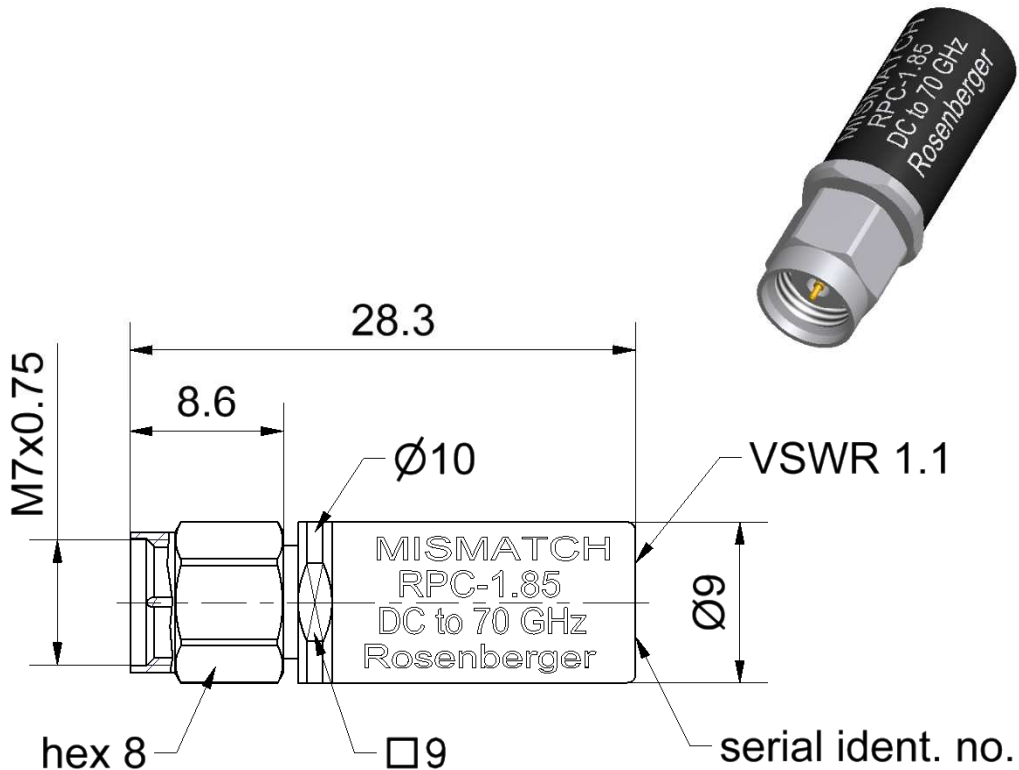

All dimensions are in mm; tolerances according to ISO 2768 m-H

**Interface**

According to  
Mechanically compatible with

IEC 61169-32  
RPC-2.40

**Documents**

Application note

AN001 "Calibration Services"

**Material and plating**

**Connector parts**

Center contact  
Outer contact  
Coupling nut  
Dielectric  
Substrate

**Material**

CuBe  
Stainless steel  
Stainless steel  
PS  
Al<sub>2</sub>O<sub>3</sub>

**Plating**

Gold, min. 1.27 µm, over nickel  
Passivated  
Passivated

Dieses Dokument ist urheberrechtlich geschützt • This document is protected by copyright • Rosenberger Hochfrequenztechnik GmbH & Co. KG

RF\_35/09;14/6.2

RPC-1.85

Mismatch  
Jack

**08S150-055S3**

**Electrical data**

Frequency range DC to 70 GHz  
 VSWR 1.1 ± 0.07, DC to 40 GHz  
 1.1 ± 0.13, 40 GHz to 70 GHz  
 DC Resistance 55 Ω ± 0.275 Ω  
 Power handling 0.5 W

**Mechanical data**

Mating cycles ≥ 500  
 Maximum torque 1.65 Nm  
 Recommended torque 0.90 Nm  
 Gauge 0.00 mm to 0.03 mm

**Environmental data**

Operating temperature range<sup>1</sup> +20 °C to +26 °C  
 Rated temperature range of use<sup>2</sup> 0 °C to +50 °C  
 Storage temperature range - 40 °C to +85 °C

RoHS compliant

<sup>1</sup> Temperature range over which these specification are valid.

<sup>2</sup> This range is underneath and above the operating temperature range, within the mismatch is fully functional and could be used without damage.

**Declaration of calibration options**

**Factory Calibration**

Standard delivery for this calibration standard includes a Factory Calibration. The Calibration Certificate issued reports individual calibration results, traceable to national / international standards. Model based standard definitions are reported in an Agilent/Keysight, Rohde & Schwarz and Anritsu compatible VNA format.

**Accredited Calibration**

Not available.

For further, more detailed information see application note AN001 on the Rosenberger homepage.

**Calibration interval**

Recommendation 12 months

**Packing**

Standard 1 pce in box  
 Weight 7.2 g/pce

While the information has been carefully compiled to the best of our knowledge, nothing is intended as representation or warranty on our part and no statement herein shall be construed as recommendation to infringe existing patents. In the effort to improve our products, we reserve the right to make changes judged to be necessary.

Draft	Date	Approved	Date	Rev.	Engineering change number	Name	Date
Kerstin Herzog	05.02.08	Markus Müller	12.09.16	c00	16-1390	Marion Striegler	12.09.16

Rosenberger Hochfrequenztechnik GmbH & Co. KG P.O.Box 1260 D-84526 Tittmoning Germany <a href="http://www.rosenberger.de">www.rosenberger.de</a>				Tel. : +49 8684 18-0 Email : <a href="mailto:info@rosenberger.de">info@rosenberger.de</a>		Page 2 / 2	
--	--	--	--	--	--	---------------	--