



REALTEK

ALC5645

Multi-Channel Audio Hub/CODEC with SounzReal™
Post-Processing for Mobile Devices

DATASHEET

Rev. 0.7

29 January 2014



Realtek Semiconductor Corp.

No. 2, Innovation Road II, Hsinchu Science Park, Hsinchu 300, Taiwan

Tel.: +886-3-578-0211. Fax: +886-3-577-6047

www.realtek.com

COPYRIGHT

©2013 Realtek Semiconductor Corp. All rights reserved. No part of this document may be reproduced, transmitted, transcribed, stored in a retrieval system, or translated into any language in any form or by any means without the written permission of Realtek Semiconductor Corp.

DISCLAIMER

Realtek provides this document “as is”, without warranty of any kind. Realtek may make improvements and/or changes in this document or in the product described in this document at any time. This document could include technical inaccuracies or typographical errors.

TRADEMARKS

Realtek is a trademark of Realtek Semiconductor Corporation. Other names mentioned in this document are trademarks/registered trademarks of their respective owners.

USING THIS DOCUMENT

This document is intended for the hardware and software engineer’s general information on the Realtek ALC5645 Audio Codec IC.

Though every effort has been made to ensure that this document is current and accurate, more information may have become available subsequent to the production of this guide.

REVISION HISTORY

Revision	Release Date	Summary
0.3	2013/3/8	First full version release
0.4	2013/8/6	Add some function description Add digital microphone interface timing
0.5	2013/10	Modify IN2P pin description
0.6	2014/01/10	Modify Register
0.7	2014/01/29	Modify Micbias output voltage

Table of Contents

1.	GENERAL DESCRIPTION	1
2.	FEATURES	2
3.	POWER/GROUND OPERATION CONDITIONS	4
4.	SYSTEM APPLICATION	4
5.	FUNCTION BLOCK AND MIXER PATH	5
5.1.	FUNCTION BLOCK.....	5
5.2.	AUDIO MIXER PATH.....	6
5.3.	DIGITAL MIXER PATH.....	7
6.	PIN ASSIGNMENTS	8
7.	PIN DESCRIPTIONS	9
7.1.	DIGITAL I/O PINS.....	9
7.2.	ANALOG I/O PINS.....	10
7.3.	FILTER/REFERENCE.....	11
7.4.	POWER/GROUND.....	11
8.	FUNCTION DESCRIPTION	12
8.1.	SYSTEM CONNECTION.....	12
8.2.	POWER.....	13
8.3.	POWER SUPPLY ON/OFF SEQUENCE.....	14
8.4.	RESET.....	15
8.4.1.	<i>Power-On Reset (POR)</i>	16
8.4.2.	<i>Software Reset</i>	16
8.5.	CLOCKING.....	16
8.5.1.	<i>Phase-Locked Loop</i>	17
8.5.2.	<i>I²C and Two I²S/PCM Interface</i>	18
8.6.	DIGITAL DATA INTERFACE.....	22
8.6.1.	<i>Two I²S/PCM Interface</i>	22
8.7.	AUDIO DATA PATH.....	26
8.7.1.	<i>2 Analog ADCs with 4-Channel Record Path</i>	26
8.7.2.	<i>4 DACs with 4-Channel Playback Path</i>	27
8.7.3.	<i>Mixers</i>	27
8.8.	ANALOG AUDIO INPUT PORT.....	28
8.9.	ANALOG AUDIO OUTPUT PORT.....	29
8.10.	MULTI-FUNCTION PINS.....	31
8.11.	DRC AND AGC FUNCTION.....	34
8.12.	SOUNZREAL™ POST-PROCESSING.....	38
8.13.	EQUALIZER BLOCK.....	38
8.14.	WIND NOISE REDUCTION FILTER.....	38
8.15.	I ² C CONTROL INTERFACE.....	41
8.15.1.	<i>Address Setting</i>	41
8.15.2.	<i>Complete Data Transfer</i>	41
8.16.	GPIO, INTERRUPT AND JACK DETECTION.....	43
8.17.	PUSH BUTTON DETECTION.....	46
8.18.	POWER MANAGEMENT.....	48
8.19.	MULTI-JACK JACK DETECTION PIN (JD1).....	49

9.	REGISTERS LIST	50
9.1.	REGISTER MAP	50
9.2.	MX-00H: S/W RESET & DEVICE ID.....	55
9.3.	MX-01H: SPEAKER OUTPUT CONTROL.....	55
9.4.	MX-02H: HEADPHONE OUTPUT CONTROL.....	56
9.5.	MX-03H: LINE OUTPUT CONTROL	58
9.6.	MX-05H: LINE OUTPUT CONTROL	59
9.7.	MX-0AH: IN1 PORT CONTROL - 1	60
9.8.	MX-0BH: IN1 PORT CONTROL - 2	60
9.9.	MX-0CH: IN1 PORT CONTROL - 3	61
9.10.	MX-0DH: IN2 INPUT CONTROL.....	61
9.11.	MX-0FH: INL & INR VOLUME CONTROL	62
9.12.	MX-19H: DACL1/R1 DIGITAL VOLUME	63
9.13.	MX-1AH: DACL2/R2 DIGITAL VOLUME	63
9.14.	MX-1BH: DACL2/R2 MUTE/UN-MUTE CONTROL	65
9.15.	MX-1CH: STEREO1 ADC DIGITAL VOLUME CONTROL.....	66
9.16.	MX-1DH: MONO ADC DIGITAL VOLUME CONTROL.....	67
9.17.	MX-1EH: ADC DIGITAL BOOST GAIN CONTROL	68
9.18.	MX-20H: MONO ADC DIGITAL BOOST GAIN CONTROL.....	69
9.19.	MX-27H: STEREO1 ADC DIGITAL MIXER CONTROL.....	69
9.20.	MX-28H: MONO ADC DIGITAL MIXER CONTROL.....	70
9.21.	MX-29H: STEREO ADC TO DAC DIGITAL MIXER CONTROL.....	71
9.22.	MX-2AH: STEREO DAC DIGITAL MIXER CONTROL.....	72
9.23.	MX-2BH: MONO DAC DIGITAL MIXER CONTROL	73
9.24.	MX-2CH: DAC DIGITAL MIXER CONTROL	74
9.25.	MX-2FH: INTERFACE DAC/ADC DATA CONTROL.....	75
9.26.	MX-31H: PDM INTERFACE CONTROL	75
9.27.	MX-3BH: RECMIXL CONTROL 1	76
9.28.	MX-3CH: RECMIXL CONTROL 2	76
9.29.	MX-3DH: RECMIXR CONTROL 1.....	77
9.30.	MX-3EH: RECMIXR CONTROL 2.....	77
9.31.	MX-3FH: HPMIXL CONTROL.....	78
9.32.	MX-40H HPMIXL CONTROL	79
9.33.	MX-41H: HPMIXR CONTROL.....	79
9.34.	MX-42H HPMIXR CONTROL.....	80
9.35.	MX-45H: HPOMIX CONTROL.....	80
9.36.	MX-46H: SPKMIXL CONTROL.....	81
9.37.	MX-47H: SPKMIXR CONTROL.....	82
9.38.	MX-48H: SPOMIX CONTROL	83
9.39.	MX-4AH: SPEAKER OUTPUT GAIN CONTROL.....	83
9.40.	MX-4DH: OUTMIXL CONTROL	84
9.41.	MX-4EH: OUTMIXL CONTROL.....	84
9.42.	MX-4FH: OUTMIXL CONTROL.....	84
9.43.	MX-50H: OUTMIXR CONTROL.....	85
9.44.	MX-51H: OUTMIXR CONTROL.....	85
9.45.	MX-52H: OUTMIXR CONTROL.....	86
9.46.	MX-53H: LOUTMIX CONTROL	86
9.47.	MX-56H: HAPTIC GENERATOR CONTROL.....	87
9.48.	MX-57H: HAPTIC GENERATOR CONTROL.....	87
9.49.	MX-58H: HAPTIC GENERATOR CONTROL.....	88
9.50.	MX-59H: HAPTIC GENERATOR CONTROL.....	88
9.51.	MX-5AH: HAPTIC GENERATOR CONTROL.....	88
9.52.	MX-5BH: HAPTIC GENERATOR CONTROL.....	88
9.53.	MX-5CH: HAPTIC GENERATOR CONTROL	88
9.54.	MX-5DH: HAPTIC GENERATOR CONTROL.....	89



9.55.	MX-5EH: HAPTIC GENERATOR CONTROL	89
9.56.	MX-5FH: HAPTIC GENERATOR CONTROL.....	89
9.57.	MX-61H: POWER MANAGEMENT CONTROL 1	89
9.58.	MX-62H: POWER MANAGEMENT CONTROL 2.....	90
9.59.	MX-63H: POWER MANAGEMENT CONTROL 3.....	91
9.60.	MX-64H: POWER MANAGEMENT CONTROL 4.....	92
9.61.	MX-65H: POWER MANAGEMENT CONTROL 5.....	93
9.62.	MX-66H: POWER MANAGEMENT CONTROL 6.....	94
9.63.	MX-6AH: PRIVATE REGISTER INDEX.....	94
9.64.	MX-6CH: PRIVATE REGISTER DATA.....	95
9.65.	MX-70H: I2S1 DIGITAL INTERFACE CONTROL	95
9.66.	MX-71H: I2S2 DIGITAL INTERFACE CONTROL	96
9.67.	MX-73H: ADC/DAC CLOCK CONTROL	97
9.68.	MX-74H: ADC/DAC HPF CONTROL	98
9.69.	MX-75H: DIGITAL MICROPHONE CONTROL 1	98
9.70.	MX-76H: DIGITAL MICROPHONE CONTROL 2.....	99
9.71.	MX-77H: TDM INTERFACE CONTROL 1	100
9.72.	MX-78H: TDM INTERFACE CONTROL 2	101
9.73.	MX-79H: TDM INTERFACE CONTROL 3	102
9.74.	MX-80H: GLOBAL CLOCK CONTROL.....	103
9.75.	MX-81H: PLL CONTROL 1.....	103
9.76.	MX-82H: PLL CONTROL 2.....	104
9.77.	MX-83H: ASRC CONTROL 1	104
9.78.	MX-84H: ASRC CONTROL 2	105
9.79.	MX-85H: ASRC CONTROL 3	106
9.80.	MX-8AH: ASRC CONTROL 4	107
9.81.	MX-8EH: HP AMP CONTROL 1	107
9.82.	MX-8FH: HP AMP CONTROL 2	108
9.83.	MX-93H: MICBIAS CONTROL.....	108
9.84.	MX-94H: JD1 CONTROL.....	109
9.85.	MX-A0H: CLASS-D AMP CONTROL.....	110
9.86.	MX-AEH: ADC PATH EQ CONTROL 1	110
9.87.	MX-AFH: ADC PATH EQ CONTROL 2	111
9.88.	MX-B0H: DAC PATH EQ CONTROL 1	112
9.89.	MX-B1H: EQ CONTROL 2.....	113
9.90.	MX-B3H: DRC CONTROL.....	114
9.91.	MX-B4H: DRC CONTROL.....	115
9.92.	MX-B5H: DRC CONTROL.....	116
9.93.	MX-B6H: DRC CONTROL.....	117
9.94.	MX-B7H: DRC CONTROL.....	118
9.95.	MX-BBH: JACK DETECTION CONTROL.....	119
9.96.	MX-BCH: JACK DETECTION CONTROL.....	120
9.97.	MX-BDH: IRQ CONTROL 1	120
9.98.	MX-BEH: IRQ CONTROL 2.....	121
9.99.	MX-BFH: IRQ CONTROL 3.....	122
9.100.	MX-C0H: GPIO CONTROL 1	123
9.101.	MX-C1H: GPIO CONTROL 2	124
9.102.	MX-C2H: GPIO CONTROL 3	125
9.103.	MX-CFH: SOUNZREAL™ BASSBACK CONTROL	125
9.104.	MX-D0H: SOUNZREAL™ TRUTREBLE CONTROL 1	126
9.105.	MX-D1H: SOUNZREAL™ TRUTREBLE CONTROL 2	126
9.106.	MX-D3H: STEREO1 ADC WIND FILTER CONTROL 1	127
9.107.	MX-D4H: STEREO1 ADC WIND FILTER CONTROL 2	128
9.108.	MX-D6H: HP AMP CONTROL	129
9.109.	MX-D9H: SOFT VOLUME & ZCD CONTROL 1	129

9.110.	MX-DAH: SOFT VOLUME & ZCD CONTROL 2	130
9.111.	MX-DBH: INLINE COMMAND CONTROL 1	131
9.112.	MX-DCH: INLINE COMMAND CONTROL 2	131
9.113.	MX-DDH: INLINE COMMAND CONTROL 3	132
9.114.	MX-E7H: DRC LIMITER CONTROL	133
9.115.	MX-E9H: DRC BASS LIMITER CONTROL	133
9.116.	MX-EAH: DRC CONTROL	134
9.117.	MX-ECH: MONO ADC WIND FILTER CONTROL 1	134
9.118.	MX-EDH: MONO ADC WIND FILTER CONTROL 2	135
9.119.	MX-F0H: DRC BASS CONTROL	136
9.120.	MX-F1H: DRC BASS CONTROL	136
9.121.	MX-F2H: DRC BASS CONTROL	137
9.122.	MX-F3H: DRC BASS CONTROL	138
9.123.	MX-F4H: DRC BASS CONTROL	138
9.124.	MX-F8H: JACK DETECTION CONTROL	139
9.125.	MX-F9H: JACK DETECTION CONTROL	140
9.126.	MX-FAH: GENERAL CONTROL 1	141
9.127.	MX-FCH: GENERAL CONTROL 2	141
9.128.	PR-3DH: ADC/DAC RESET CONTROL	142
9.129.	PR-90H: HP AMPLITUDE THRESHOLD CONTROL	142
9.130.	PR-91H: HP AMPLITUDE THRESHOLD CONTROL	142
9.131.	PR-A4H: DAC_L EQ (LPF:A1)	143
9.132.	PR-A5H: DAC_L EQ (LPF:H0)	143
9.133.	PR-A6H: DAC_R EQ (LPF:A1)	143
9.134.	PR-A7H: DAC_R EQ (LPF:H0)	143
9.135.	PR-AEH: DAC_L EQ (BPF2:A1)	144
9.136.	PR-AFH: DAC_L EQ (BPF2:A2)	144
9.137.	PR-B0H: DAC_L EQ (BPF2:H0)	144
9.138.	PR-B1H: DAC_R EQ (BPF2:A1)	144
9.139.	PR-B2H: DAC_R EQ (BPF2:A2)	145
9.140.	PR-B3H: DAC_R EQ (BPF2:H0)	145
9.141.	PR-B4H: DAC_L EQ (BPF3:A1)	145
9.142.	PR-B5H: DAC_L EQ (BPF3:A2)	145
9.143.	PR-B6H: DAC_L EQ (BPF3:H0)	145
9.144.	PR-B7H: DAC_R EQ (BPF3:A1)	146
9.145.	PR-B8H: DAC_R EQ (BPF3:A2)	146
9.146.	PR-B9H: DAC_R EQ (BPF3:H0)	146
9.147.	PR-BAH: DAC_L EQ (BPF4:A1)	146
9.148.	PR-BBH: DAC_L EQ (BPF4:A2)	147
9.149.	PR-BCH: DAC_L EQ (BPF4:H0)	147
9.150.	PR-BDH: DAC_R EQ (BPF4:A1)	147
9.151.	PR-BEH: DAC_R EQ (BPF4:A2)	147
9.152.	PR-BFH: DAC_R EQ (BPF4:H0)	148
9.153.	PR-C0H: DAC_L EQ (HPF1:A1)	148
9.154.	PR-C1H: DAC_L EQ (HPF1:H0)	148
9.155.	PR-C2H: DAC_R EQ (HPF1:A1)	148
9.156.	PR-C3H: DAC_R EQ (HPF1:H0)	149
9.157.	PR-C4H: DAC_L EQ (HPF2:A1)	149
9.158.	PR-C5H: DAC_L EQ (HPF2:A2)	149
9.159.	PR-C6H: DAC_L EQ (HPF2:H0)	149
9.160.	PR-C7H: DAC_R EQ (HPF2:A1)	150
9.161.	PR-C8H: DAC_R EQ (HPF2:A2)	150
9.162.	PR-C9H: DAC_R EQ (HPF2:H0)	150
9.163.	PR-CAH: DAC_L EQ PRE-VOLUME CONTROL	150
9.164.	PR-CBH: DAC_R EQ PRE-VOLUME CONTROL	151

9.165.	PR-CCH: DAC_L EQ POST-VOLUME CONTROL	151
9.166.	PR-CDH: DAC_R EQ POST-VOLUME CONTROL	151
9.167.	PR-CEH: ADC EQ (LPF:A1)	152
9.168.	PR-CFH: ADC EQ (LPF:H0).....	152
9.169.	PR-D0H: ADC EQ (BPF1:A1)	152
9.170.	PR-D1H: ADC EQ (BPF1:A2)	153
9.171.	PR-D2H: ADC EQ (BPF1:H0).....	153
9.172.	PR-D3H: ADC EQ (BPF2:A1)	153
9.173.	PR-D4H: ADC EQ (BPF2:A2)	153
9.174.	PR-D5H: ADC EQ (BPF2:H0).....	154
9.175.	PR-D6H: ADC EQ (BPF3:A1)	154
9.176.	PR-D7H: ADC EQ (BPF3:A2)	154
9.177.	PR-D8H: ADC EQ (BPF3:H0).....	154
9.178.	PR-D9H: ADC EQ (BPF4:A1)	155
9.179.	PR-DAH: ADC EQ (BPF4:A2)	155
9.180.	PR-DBH: ADC EQ (BPF4:H0).....	155
9.181.	PR-DCH: ADC EQ (HPF1:A1)	155
9.182.	PR-DDH: ADC EQ (HPF1:H0).....	156
9.183.	PR-E1H: ADC EQ PRE-VOLUME CONTROL.....	156
9.184.	PR-E2H: ADC EQ POST-VOLUME CONTROL.....	156
9.185.	PR-E5H: DAC_L BIQUAD EQ (BPF1:H0-1)	156
9.186.	PR-E6H: DAC_L BIQUAD EQ (BPF1:H0-2)	157
9.187.	PR-E7H: DAC_L BIQUAD EQ (BPF1:B1-1).....	157
9.188.	PR-E8H: DAC_L BIQUAD EQ (BPF1:B1-2).....	157
9.189.	PR-E9H: DAC_L BIQUAD EQ (BPF1:B2-1).....	157
9.190.	PR-EAH: DAC_L BIQUAD EQ (BPF1:B2-2).....	158
9.191.	PR-EBH: DAC_L BIQUAD EQ (BPF1:A1-1).....	158
9.192.	PR-ECH: DAC_L BIQUAD EQ (BPF1:A1-2).....	158
9.193.	PR-EDH: DAC_L BIQUAD EQ (BPF1:A2-1)	158
9.194.	PR-EEH: DAC_L BIQUAD EQ (BPF1:A2-2).....	158
9.195.	PR-EFH: DAC_R BIQUAD EQ (BPF1:H0-1).....	159
9.196.	PR-F0H: DAC_R BIQUAD EQ (BPF1:H0-2)	159
9.197.	PR-F1H: DAC_R BIQUAD EQ (BPF1:B1-1).....	159
9.198.	PR-F2H: DAC_R BIQUAD EQ (BPF1:B1-2).....	159
9.199.	PR-F3H: DAC_R BIQUAD EQ (BPF1:B2-1).....	160
9.200.	PR-F4H: DAC_R BIQUAD EQ (BPF1:B2-2).....	160
9.201.	PR-F5H: DAC_R BIQUAD EQ (BPF1:A1-1)	160
9.202.	PR-F6H: DAC_R BIQUAD EQ (BPF1:A1-2)	160
9.203.	PR-F7H: DAC_R BIQUAD EQ (BPF1:A2-1)	161
9.204.	PR-F8H: DAC_R BIQUAD EQ (BPF1:A2-2)	161
9.205.	MX-FEH: VENDOR ID	161
10.	ELECTRICAL CHARACTERISTICS.....	162
10.1.	DC CHARACTERISTICS	162
10.1.1.	<i>Absolute Maximum Ratings</i>	162
10.1.2.	<i>Recommended Operating Conditions</i>	162
10.1.3.	<i>Static Characteristics</i>	162
10.2.	ANALOG PERFORMANCE CHARACTERISTICS.....	163
10.3.	SIGNAL TIMING.....	165
10.3.1.	<i>I²C Control Interface</i>	165
10.3.2.	<i>I²S/PCM Interface Master Mode</i>	166
10.3.3.	<i>I²S/PCM Interface Slave Mode</i>	167
10.3.4.	<i>Digital Microphone Interface</i>	168
11.	APPLICATION CIRCUITS	169

12.	PACKAGE INFORMATION	171
12.1.	MECHANICAL DIMENSIONS.....	171
12.2.	PACKAGE THERMAL INFORMATION	172
13.	ORDERING INFORMATION	173

List of Tables

TABLE 1.	DIGITAL I/O PINS	9
TABLE 2.	ANALOG I/O PINS.....	10
TABLE 3.	FILTER/REFERENCE.....	11
TABLE 4.	POWER/GROUND	11
TABLE 5.	POWER SUPPLY FOR BEST PERFORMANCE.....	13
TABLE 6.	POWER SUPPLY CONDITION FOR POWER DOWN LEAKAGE.....	13
TABLE 7.	RESET OPERATION	16
TABLE 8.	POWER-ON RESET VOLTAGE.....	16
TABLE 9.	CLOCK SETTING TABLE FOR 48K (UNIT: MHz)	18
TABLE 10.	CLOCK SETTING TABLE FOR 44.1K (UNIT: MHz)	18
TABLE 11.	THE RELATIVE OF SYSCLK/BCLK/LRCK.....	19
TABLE 12.	REGISTER SETTINGS FOR ASRC FUNCTION ON SLAVE MODE.....	21
TABLE 13.	SAMPLE RATE WITH FILTER COEFFICIENT FOR WIND FILTER.....	39
TABLE 14.	ADDRESS SETTING (0x34H)	41
TABLE 15.	WRITE WORD PROTOCOL	42
TABLE 16.	READ WORD PROTOCOL.....	42
TABLE 17.	REGISTER MAP.....	50
TABLE 18.	MX-00H: S/W RESET.....	55
TABLE 19.	MX-01H: SPEAKER OUTPUT CONTROL	55
TABLE 20.	MX-02H: HEADPHONE OUTPUT CONTROL.....	56
TABLE 21.	MX-03H: LINE OUTPUT CONTROL.....	58
TABLE 22.	MX-05H: LINE OUTPUT CONTROL.....	59
TABLE 23.	MX-0DH: IN1 INPUT CONTROL - 1	60
TABLE 24.	MX-0BH: IN1 INPUT CONTROL - 2.....	60
TABLE 25.	MX-0CH: IN1 INPUT CONTROL - 3.....	61
TABLE 26.	MX-0DH: IN2 INPUT CONTROL	61
TABLE 27.	MX-0FH: INL & INR VOLUME CONTROL.....	62
TABLE 28.	MX-19H: DACL1/R1 DIGITAL VOLUME	63
TABLE 29.	MX-1AH: DACL2/R2 DIGITAL VOLUME.....	63
TABLE 30.	MX-1BH: DACL2/R2 MUTE/UN-MUTE CONTROL.....	65
TABLE 31.	MX-1CH: STEREO1 ADC DIGITAL VOLUME CONTROL	66
TABLE 32.	MX-1DH: MONO ADC DIGITAL VOLUME CONTROL	67
TABLE 33.	MX-1EH: ADC DIGITAL BOOST GAIN CONTROL.....	68
TABLE 34.	MX-20H: MONO ADC DIGITAL BOOST GAIN CONTROL.....	69
TABLE 35.	MX-27H: STEREO1 ADC DIGITAL MIXER CONTROL	69
TABLE 36.	MX-28H: MONO ADC DIGITAL MIXER CONTROL	70
TABLE 37.	MX-29H: STEREO ADC TO DAC DIGITAL MIXER CONTROL.....	71
TABLE 38.	MX-2AH: STEREO DAC DIGITAL MIXER CONTROL	72
TABLE 39.	MX-2BH: MONO DAC DIGITAL MIXER CONTROL.....	73
TABLE 40.	MX-2CH: DAC DIGITAL MIXER CONTROL.....	74
TABLE 41.	MX-2FH: INTERFACE DAC/ADC DATA CONTROL.....	75
TABLE 42.	MX-31H: PDM INTERFACE CONTROL.....	75
TABLE 43.	MX-3BH: RECMIXL CONTROL 1	76
TABLE 44.	MX-3CH: RECMIXL CONTROL 2	76
TABLE 45.	MX-3DH: RECMIXR CONTROL 1	77
TABLE 46.	MX-3EH: RECMIXR CONTROL 2	77
TABLE 47.	MX-3FH: HPMIXL CONTROL	78
TABLE 48.	MX-40H: HPMIXL CONTROL.....	79
TABLE 49.	MX-41H: HPMIXR CONTROL	79
TABLE 50.	MX-42H: HPMIXR CONTROL	80
TABLE 51.	MX-45H: HPOMIX CONTROL	80
TABLE 52.	MX-46H: SPKMIXL CONTROL	81

TABLE 53.	MX-47H: SPKMIXR CONTROL	82
TABLE 54.	MX-48H: SPOMIX CONTROL.....	83
TABLE 55.	MX-4AH: SPEAKER OUTPUT GAIN CONTROL	83
TABLE 56.	MX-4DH: OUTMIXL CONTROL.....	84
TABLE 57.	MX-4EH: OUTMIXL CONTROL	84
TABLE 58.	MX-4FH: OUTMIXL CONTROL	84
TABLE 59.	MX-50H: OUTMIXR CONTROL	85
TABLE 60.	MX-51H: OUTMIXR CONTROL	85
TABLE 61.	MX-52H: OUTMIXR CONTROL	86
TABLE 62.	MX-53H: LOUTMIX CONTROL	86
TABLE 63.	MX-56H: HAPTIC GENERATOR CONTROL	87
TABLE 64.	MX-57H: HAPTIC GENERATOR CONTROL	87
TABLE 65.	MX-58H: HAPTIC GENERATOR CONTROL	88
TABLE 66.	MX-59H: HAPTIC GENERATOR CONTROL	88
TABLE 67.	MX-5AH: HAPTIC GENERATOR CONTROL	88
TABLE 68.	MX-5BH: HAPTIC GENERATOR CONTROL	88
TABLE 69.	MX-5CH: HAPTIC GENERATOR CONTROL	88
TABLE 70.	MX-5DH: HAPTIC GENERATOR CONTROL	89
TABLE 71.	MX-5EH: HAPTIC GENERATOR CONTROL.....	89
TABLE 72.	MX-5FH: HAPTIC GENERATOR CONTROL.....	89
TABLE 73.	MX-61H: POWER MANAGEMENT CONTROL 1	89
TABLE 74.	MX-62H: POWER MANAGEMENT CONTROL 2	90
TABLE 75.	MX-63H: POWER MANAGEMENT CONTROL 3	91
TABLE 76.	MX-64H: POWER MANAGEMENT CONTROL 4	92
TABLE 77.	MX-65H: POWER MANAGEMENT CONTROL 5	93
TABLE 78.	MX-66H: POWER MANAGEMENT CONTROL 6	94
TABLE 79.	MX-6AH: PRIVATE REGISTER INDEX	94
TABLE 80.	MX-6CH: PRIVATE REGISTER DATA	95
TABLE 81.	MX-70H: I2S1 DIGITAL INTERFACE CONTROL.....	95
TABLE 82.	MX-71H: I2S2 DIGITAL INTERFACE CONTROL.....	96
TABLE 83.	MX-73H: ADC/DAC CLOCK CONTROL	97
TABLE 84.	MX-74H: ADC/DAC HPF CONTROL	98
TABLE 85.	MX-75H: DIGITAL MICROPHONE CONTROL 1	98
TABLE 86.	MX-76H: DIGITAL MICROPHONE CONTROL 2	99
TABLE 87.	MX-77H: TDM INTERFACE CONTROL 1	100
TABLE 88.	MX-78H: TDM INTERFACE CONTROL 2	101
TABLE 89.	MX-79H: TDM INTERFACE CONTROL 3	102
TABLE 90.	MX-80H: GLOBAL CLOCK CONTROL	103
TABLE 91.	MX-81H: PLL CONTROL 1	103
TABLE 92.	MX-82H: PLL CONTROL 2	104
TABLE 93.	MX-83H: ASRC CONTROL 1	104
TABLE 94.	MX-84H: ASRC CONTROL 2.....	105
TABLE 95.	MX-85H: ASRC CONTROL 3.....	106
TABLE 96.	MX-8AH: ASRC CONTROL 4.....	107
TABLE 97.	MX-8EH: HP AMP CONTROL 1	107
TABLE 98.	MX-8FH: HP AMP CONTROL 2	108
TABLE 99.	MX-93H: MICBIAS CONTROL	108
TABLE 100.	MX-94H: JD1 CONTROL	109
TABLE 101.	MX-A0H: CLASS-D AMP CONTROL	110
TABLE 102.	MX-AEH: ADC PATH EQ CONTROL 1	110
TABLE 103.	MX-AFH: ADC PATH EQ CONTROL 2	111
TABLE 104.	MX-B0H: DAC PATH EQ CONTROL 1	112
TABLE 105.	MX-B1H: EQ CONTROL 2	113
TABLE 106.	MX-B3H: DRC CONTROL	114
TABLE 107.	MX-B4H: DRC CONTROL	115

TABLE 108.	MX-B5H: DRC CONTROL	116
TABLE 109.	MX-B6H: DRC CONTROL	117
TABLE 110.	MX-B7H: DRC CONTROL	118
TABLE 111.	MX-BBH: JACK DETECTION CONTROL	119
TABLE 112.	MX-BCH: JACK DETECTION CONTROL	120
TABLE 113.	MX-BDH: IRQ CONTROL 1	120
TABLE 114.	MX-BEH: IRQ CONTROL 2	121
TABLE 115.	MX-BFH: IRQ CONTROL 3	122
TABLE 116.	MX-C0H: GPIO CONTROL 1	123
TABLE 117.	MX-C1H: GPIO CONTROL 2	124
TABLE 118.	MX-C2H: GPIO CONTROL 3	125
TABLE 119.	MX-CFH: SOUNZREAL™ BASSBACK CONTROL	125
TABLE 120.	MX-D0H: SOUNZREAL™ TRUTREBLE CONTROL 1	126
TABLE 121.	MX-D1H: SOUNZREAL™ TRUTREBLE CONTROL 2	126
TABLE 122.	MX-D3H: STEREO1 ADC WIND FILTER CONTROL 1	127
TABLE 123.	MX-D4H: STEREO1 ADC WIND FILTER CONTROL 2	128
TABLE 124.	MX-D6H: HP AMP CONTROL	129
TABLE 125.	MX-D9H: SOFT VOLUME & ZCD CONTROL 1	129
TABLE 126.	MX-DAH: SOFT VOLUME & ZCD CONTROL 2	130
TABLE 127.	MX-DBH: INLINE COMMAND CONTROL 1	131
TABLE 128.	MX-DCH: INLINE COMMAND CONTROL 2	132
TABLE 129.	MX-DDH: INLINE COMMAND CONTROL 3	132
TABLE 130.	MX-E7H: DRC LIMITER CONTROL	133
TABLE 131.	MX-E9H: DRC BASS LIMITER CONTROL	133
TABLE 132.	MX-EAH: DRC CONTROL	134
TABLE 133.	MX-ECH: MONO ADC WIND FILTER CONTROL 1	134
TABLE 134.	MX-EDH: MONO ADC WIND FILTER CONTROL 2	135
TABLE 135.	MX-F0H: DRC BASS CONTROL	136
TABLE 136.	MX-F1H: DRC BASS CONTROL	136
TABLE 137.	MX-F2H: DRC BASS CONTROL	137
TABLE 138.	MX-F3H: DRC BASS CONTROL	138
TABLE 139.	MX-F4H: DRC BASS CONTROL	138
TABLE 140.	MX-F8H: JACK DETECTION CONTROL	139
TABLE 141.	MX-F9H: JACK DETECTION CONTROL	140
TABLE 142.	MX-FAH: GENERAL CONTROL 1	141
TABLE 143.	MX-FCH: GENERAL CONTROL 2	141
TABLE 144.	PR-3DH: ADC/DAC RESET CONTROL	142
TABLE 145.	PR-90H: HP AMPLITUDE THRESHOLD CONTROL	142
TABLE 146.	PR-91H: HP AMPLITUDE THRESHOLD CONTROL	143
TABLE 147.	PR-A4H: DAC_L EQ (LPF:A1)	143
TABLE 148.	PR-A5H: DAC_L EQ (LPF:H0)	143
TABLE 149.	PR-A6H: DAC_R EQ (LPF:A1)	143
TABLE 150.	PR-A7H: DAC_R EQ (LPF:H0)	143
TABLE 151.	PR-AEH: DAC_L EQ (BPF2:A1)	144
TABLE 152.	PR-AFH: DAC_L EQ (BPF2:A2)	144
TABLE 153.	PR-B0H: DAC_L EQ (BPF2:H0)	144
TABLE 154.	PR-B1H: DAC_R EQ (BPF2:A1)	144
TABLE 155.	PR-B2H: DAC_R EQ (BPF2:A2)	145
TABLE 156.	PR-B3H: DAC_R EQ (BPF2:H0)	145
TABLE 157.	PR-B4H: DAC_L EQ (BPF3:A1)	145
TABLE 158.	PR-B5H: DAC_L EQ (BPF3:A2)	145
TABLE 159.	PR-B6H: DAC_L EQ (BPF3:H0)	146
TABLE 160.	PR-B7H: DAC_R EQ (BPF3:A1)	146
TABLE 161.	PR-B8H: DAC_R EQ (BPF3:A2)	146
TABLE 162.	PR-B9H: DAC_R EQ (BPF3:H0)	146

TABLE 163.	PR-BAH: DAC_L EQ (BPF4:A1)	147
TABLE 164.	PR-BBH: DAC_L EQ (BPF4:A2)	147
TABLE 165.	PR-BCH: DAC_L EQ (BPF4:H0)	147
TABLE 166.	PR-BDH: DAC_R EQ (BPF4:A1)	147
TABLE 167.	PR-BEH: DAC_R EQ (BPF4:A2)	148
TABLE 168.	PR-BFH: DAC_R EQ (BPF4:H0)	148
TABLE 169.	PR-C0H: DAC_L EQ (HPF1:A1)	148
TABLE 170.	PR-C1H: DAC_L EQ (HPF1:H0)	148
TABLE 171.	PR-C2H: DAC_R EQ (HPF1:A1)	149
TABLE 172.	PR-C3H: DAC_R EQ (HPF1:H0)	149
TABLE 173.	PR-C4H: DAC_L EQ (HPF2:A1)	149
TABLE 174.	PR-C5H: DAC_L EQ (HPF2:A2)	149
TABLE 175.	PR-C6H: DAC_L EQ (HPF2:H0)	150
TABLE 176.	PR-C7H: DAC_R EQ (HPF2:A1)	150
TABLE 177.	PR-C8H: DAC_R EQ (HPF2:A2)	150
TABLE 178.	PR-C9H: DAC_R EQ (HPF2:H0)	150
TABLE 179.	PR-CAH: DAC_L EQ PRE-VOLUME CONTROL	151
TABLE 180.	PR-CBH: DAC_R EQ PRE-VOLUME CONTROL	151
TABLE 181.	PR-CCH: DAC_L EQ POST-VOLUME CONTROL	151
TABLE 182.	PR-CDH: DAC_R EQ POST-VOLUME CONTROL	152
TABLE 183.	PR-CEH: ADC EQ (LPF:A1)	152
TABLE 184.	PR-CFH: ADC EQ (LPF:H0)	152
TABLE 185.	PR-D0H: ADC EQ (BPF1:A1)	152
TABLE 186.	PR-D1H: ADC EQ (BPF1:A2)	153
TABLE 187.	PR-D2H: ADC EQ (BPF1:H0)	153
TABLE 188.	PR-D3H: ADC EQ (BPF2:A1)	153
TABLE 189.	PR-D4H: ADC EQ (BPF2:A2)	153
TABLE 190.	PR-D5H: ADC EQ (BPF2:H0)	154
TABLE 191.	PR-D6H: ADC EQ (BPF3:A1)	154
TABLE 192.	PR-D7H: ADC EQ (BPF3:A2)	154
TABLE 193.	PR-D8H: ADC EQ (BPF3:H0)	154
TABLE 194.	PR-D9H: ADC EQ (BPF4:A1)	155
TABLE 195.	PR-DAH: ADC EQ (BPF4:A2)	155
TABLE 196.	PR-DBH: ADC EQ (BPF4:H0)	155
TABLE 197.	PR-DCH: ADC EQ (HPF1:A1)	155
TABLE 198.	PR-DDH: ADC EQ (HPF1:H0)	156
TABLE 199.	PR-E1H: ADC EQ PRE-VOLUME CONTROL	156
TABLE 200.	PR-E2H: ADC EQ POST-VOLUME CONTROL	156
TABLE 201.	PR-E5H: DAC_L BIQUAD EQ (BPF1:H0-1)	156
TABLE 202.	PR-E6H: DAC_L BIQUAD EQ (BPF1:H0-2)	157
TABLE 203.	PR-E7H: DAC_L BIQUAD EQ (BPF1:B1-1)	157
TABLE 204.	PR-E8H: DAC_L BIQUAD EQ (BPF1:B1-2)	157
TABLE 205.	PR-E9H: DAC_L BIQUAD EQ (BPF1:B2-1)	157
TABLE 206.	PR-EAH: DAC_L BIQUAD EQ (BPF1:B2-2)	158
TABLE 207.	PR-EBH: DAC_L BIQUAD EQ (BPF1:A1-1)	158
TABLE 208.	PR-ECH: DAC_L BIQUAD EQ (BPF1:A1-2)	158
TABLE 209.	PR-EDH: DAC_L BIQUAD EQ (BPF1:A2-1)	158
TABLE 210.	PR-EEH: DAC_L BIQUAD EQ (BPF1:A2-2)	159
TABLE 211.	PR-EFH: DAC_R BIQUAD EQ (BPF1:H0-1)	159
TABLE 212.	PR-F0H: DAC_R BIQUAD EQ (BPF1:H0-2)	159
TABLE 213.	PR-F1H: DAC_R BIQUAD EQ (BPF1:B1-1)	159
TABLE 214.	PR-F2H: DAC_R BIQUAD EQ (BPF1:B1-2)	160
TABLE 215.	PR-F3H: DAC_R BIQUAD EQ (BPF1:B2-1)	160
TABLE 216.	PR-F4H: DAC_R BIQUAD EQ (BPF1:B2-2)	160
TABLE 217.	PR-F5H: DAC_R BIQUAD EQ (BPF1:A1-1)	160

TABLE 218.	PR-F6H: DAC_R BIQUAD EQ (BPF1:A1-2).....	161
TABLE 219.	PR-F7H: DAC_R BIQUAD EQ (BPF1:A2-1).....	161
TABLE 220.	PR-F8H: DAC_R BIQUAD EQ (BPF1:A2-2).....	161
TABLE 221.	MX-FEH: VENDOR ID.....	161
TABLE 222.	ABSOLUTE MAXIMUM RATINGS.....	162
TABLE 223.	RECOMMENDED OPERATING CONDITIONS.....	162
TABLE 224.	STATIC CHARACTERISTICS.....	162
TABLE 225.	ANALOG PERFORMANCE CHARACTERISTICS.....	163
TABLE 226.	I ² C TIMING.....	165
TABLE 227.	TIMING OF I ² S/PCM MASTER MODE.....	166
TABLE 228.	I ² S/PCM SLAVE MODE TIMING.....	167
TABLE 229.	DIGITAL MICROPHONE INTERFACE TIMING.....	168
TABLE 230.	THERMAL INFORMATION.....	172
TABLE 231.	ORDERING INFORMATION.....	173

List of Figures

FIGURE 1.	BLOCK DIAGRAM	5
FIGURE 2.	AUDIO MIXER PATH	6
FIGURE 3.	DIGITAL MIXER PATH	7
FIGURE 4.	PIN ASSIGNMENTS	8
FIGURE 5.	GENERAL SYSTEM CONNECTION	12
FIGURE 6.	POWER ON/OFF TIMING	15
FIGURE 7.	AUDIO CLOCK TREE	17
FIGURE 8.	SYSTEM CONNECTION FOR ASRC FUNCTION	20
FIGURE 9.	PCM MONO DATA MODE A FORMAT (BCLK POLARITY=0)	22
FIGURE 10.	PCM MONO DATA MODE B FORMAT (BCLK POLARITY=1)	22
FIGURE 11.	PCM MONO DATA MODE B FORMAT (BCLK POLARITY=0)	23
FIGURE 12.	PCM STEREO DATA MODE A FORMAT (BCLK POLARITY=0)	23
FIGURE 13.	PCM TDM DATA MODE A FORMAT (BCLK POLARITY=0)	23
FIGURE 14.	PCM STEREO DATA MODE B FORMAT (BCLK POLARITY=0)	24
FIGURE 15.	PCM TDM DATA MODE B FORMAT (BCLK POLARITY=0)	24
FIGURE 16.	I ² S DATA FORMAT (BCLK POLARITY=0)	24
FIGURE 17.	I ² S TDM DATA FORMAT (BCLK POLARITY=0)	25
FIGURE 18.	LEFT-JUSTIFIED DATA FORMAT (BCLK POLARITY=0)	25
FIGURE 19.	LEFT-JUSTIFIED TDM DATA FORMAT (BCLK POLARITY=0)	25
FIGURE 20.	4-CHANNEL RECORDING PATH	26
FIGURE 21.	4-CHANNEL PLAYBACK PATH	27
FIGURE 22.	STEREO BTL SPEAKER OUTPUT	30
FIGURE 23.	MULTI-BAND DRC FUNCTION BLOCK	34
FIGURE 24.	DAC DRC FUNCTION BLOCK	35
FIGURE 25.	ADC AGC FUNCTION BLOCK	35
FIGURE 26.	DRC/AGC FOR PLAYBACK/RECORDING MODE	36
FIGURE 27.	DRC/AGC FOR NOISE GATE MODE	37
FIGURE 28.	DATA TRANSFER OVER I ² C CONTROL INTERFACE	41
FIGURE 29.	GPIO FUNCTION BLOCK	43
FIGURE 30.	IRQ FUNCTION BLOCK	44
FIGURE 31.	POWER MANAGEMENT	48
FIGURE 32.	I ² C CONTROL INTERFACE	165
FIGURE 33.	TIMING OF I ² S/PCM MASTER MODE	166
FIGURE 34.	I ² S/PCM SLAVE MODE TIMING	167
FIGURE 35.	DIGITAL MICROPHONE INTERFACE TIMING	168
FIGURE 36.	APPLICATION CIRCUIT	170
FIGURE 37.	PACKAGE DIMENSION	171

1. General Description

The ALC5645 is a high performance, low power, dual I²S interface audio CODEC. Dual I²S interface makes the ALC5645 be able to connect to different devices and to be an Audio Hub in a system. TDM (Time Division Multiplexing) interface is also available and allows multiple channels of data to be transmitted simultaneously on the same bus. Asynchronous Sample Rate Converter (ASRC) provides independent and asynchronous connections to different processors, such as an application processor, baseband processor or wireless transceiver (BT).

Stereo Class-D speaker amplifiers provide 1.5W per channel into 8Ω or 2.8W per channel into 4Ω with a 5V supply, with high THD+N performance, excellent PSRR and low EMI.

The ALC5645 features an ultra low power cap-free headphone amplifier. It consumes only less than 5mW power during playback, providing mobile system longer battery life under headphone listening mode.

The advanced DRC (Dynamic Range Control) enables further digital sound processing capabilities on playback paths. Advanced DRC function comprises multi-section and multi-band parts. The multi-section DRC monitors the DAC output level continuously. When the output level is low, multi-section DRC increases the input signal gain to raise the output loudness. When there is a peak signal, it reduces the applied gain to avoid hard clipping. This ensures signal level maintenance, maximizes loudness, and prevents audio clipping and speaker damage. Two individual multi-section DRCs are designed in ALC5645 for high-frequency and low-frequency bands, i.e. multi-band DRC. The two DRCs parameters can be set separately to create different curves for high-frequency and low frequency-bands. The crossover frequency to define high-frequency and low-frequency bands is programmable.

The 14-band parametric Equalizer consists of 7-band EQ for each L/R playback path. Gain, center frequency, and bandwidth of each 7-band EQ can be programmed independently to compensate frequency response of L/R speakers, and to meet various user preferences.

The DRC in ALC5645 can be used as an AGC (Auto Gain Control) to keep recording volume constant when the input amplitude varies over a wide range. In addition, a wind noise reduction filter is built in on the recording path. The filter detects and reduces wind noise level to maintain recording quality. The ALC5645 also integrates an independent 6-band parametric Equalizer on the recording path. This could be used for microphone frequency response compensation.

SounzReal™ Post-Processing technology is configurable to provide better listening experience. BassBack EXP™ brings LFE(low frequency effect) to listeners without subwoofer needed. TruTreble EXP™ adds processed harmonic tones at high frequency, bringing more melody and details for music listening.

2. Features

- SounzReal™ Post-Processing
 - TruTreble
 - OmniSound
- Parametric 14 bands equalizer (EQ) for playback path – 7 bands for each L/R path, independent control
- Parametric 6 bands equalizer (EQ) for recording path
- Advanced DRC with multi-section and multi-band compressor function for playback/recording path
- Sound detection wake up technology
- Wind noise reduction filter
- One 24bit/8kHz ~ 192kHz I2S/PCM/TDM digital interface
- One 24bit/8kHz ~ 192kHz I2S/PCM digital interface
- Digital asynchronous sampling rate converter (ASRC) function
- I2C control interface
- 2 stereo digital microphone interfaces
- 4 Digital-to-Analog Converter with 100dBA SNR
- 2 Analog-to-Digital Converter with 94dBA SNR
- 2 single-ended analog microphone inputs with pre-amplifiers (+20/24/30/35/40/44/50/52dB) and low noise microphone bias
 - MIC input to ADC with 50dB Boost, SNR>66dBA, THD+N<-65dB
 - Headset microphone and ground auto switch
- Stereo line input
 - -85dB THD+N (with 0dB gain path)
 - 94dBA SNR (with 0dB gain path)
- Stereo single-ended/mono differential line output
 - -85dB THD+N (with 0dB gain path, 10k ohm loading)
 - 98dBA SNR (with 0dB gain path, 10k ohm loading)
- Stereo BTL (Bridge-Tied Load) Class-D amplifier
 - 650mW/CH (AVDD=1.8V, SPKVDD=3.6V, THD+N <= 1%, 8Ohm)
 - 500mW/CH (AVDD=1.8V, SPKVDD=3.6V, THD+N <= 0.1%, 8Ohm)

- 2.5W/CH (AVDD=1.8V, SPKVDD=5.0V, THD+N <= 10%, 4Ohm)
- 2.1W/CH (AVDD=1.8V, SPKVDD=5.0V, THD+N <= 1%, 4Ohm)
- 1.2W/CH (AVDD=1.8V, SPKVDD=5.0V, THD+N <= 1%, 8Ohm)
- Speaker auto ratio gain and SPKVDD detection
 - Auto ratio gain for AVDD=1.8V with SPKVDD=3.3V ~ 5.0V
 - 4-bit PVDD Detection for SPKVDD=3.3V ~ 5.0V with AVDD=1.8V
- Stereo headphone output and without DC blocking capacitors
 - 20mW/CH (AVDD=CPVDD=1.8V, THD+N <= -80dB, 16Ohm)
 - 100dBA SNR (with 0dB gain path)
- Ultra-Low-Power for headphone playback
 - Quiescent power consumption around 5mW (AVDD=DBVDD=CPVDD=1.8V, DCVDD=1.2V, 32Ohm, With I2S clock input)
 - Playback power consumption <=13mW (AVDD=DBVDD=CPVDD=1.8V, DCVDD=1.2V, 32Ohm, With I2S clock input, Po=1mW)
- Multiple audio jack insert detection function
- Headset in-line multi-function control support
- Power management and enhanced power saving
- Internal PLL can receive wide range clock input
- Two adjustable MICBIAS (2.7V or 1.8V)
- QFN-48 (6mmx6mm) package

3. Power/Ground Operation Conditions

POWER TYPE	DESCRIPTION	MIN	TYP	MAX	UNIT
DBVDD	Digital I/O Power	1.71	1.8	3.6	V
DCVDD	Digital Core Power	1.1	1.2	1.4	V
AVDD	Analog Power	1.71	1.8	1.9	V
DACREF	Analog Power	1.71	1.8	1.9	V
MICVDD	Microphone Bias Power	3.0	3.3	3.6	V
CPVDD	Charge Pump Power	1.71	1.8	1.9	V
SPKVDDL/R	Speaker Power	3.0	5.0	5.5	V
DGND, AGND, CPGND, SPKGND,	Ground		0		V

4. System Application

- Smart Phones
- Tablet

5. Function Block and Mixer Path

5.1. Function Block

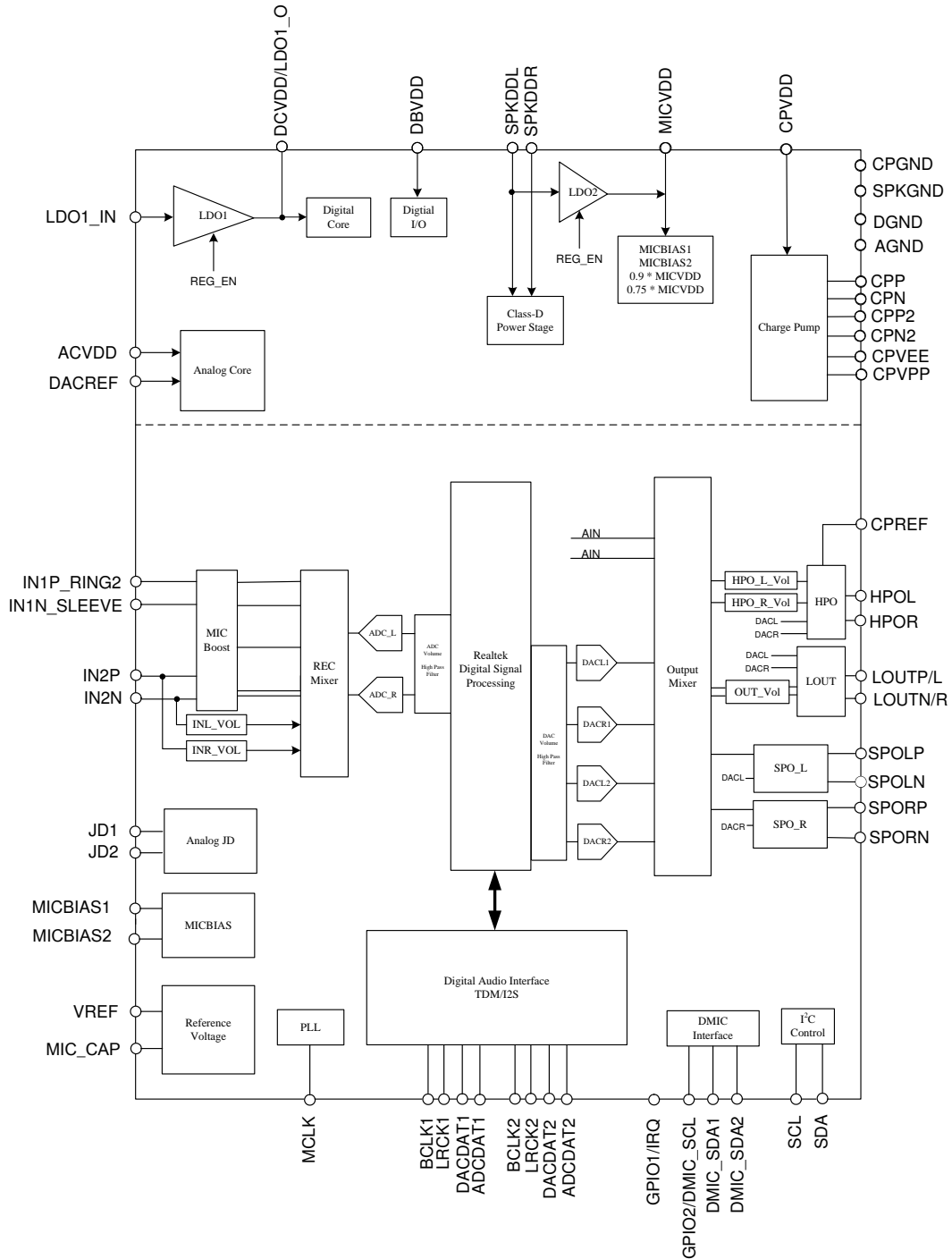


Figure 1. Block Diagram

5.2. Audio Mixer Path

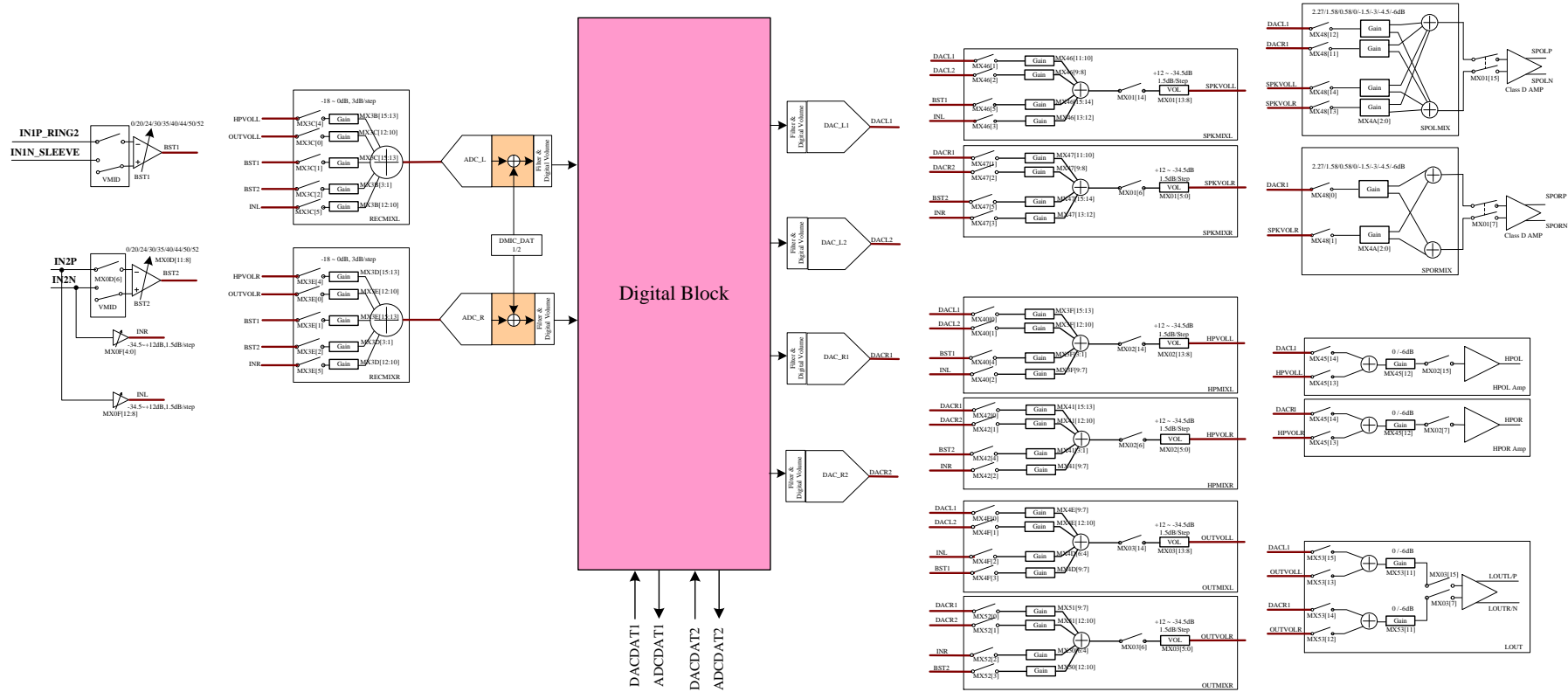


Figure 2. Audio Mixer Path

5.3. Digital Mixer Path

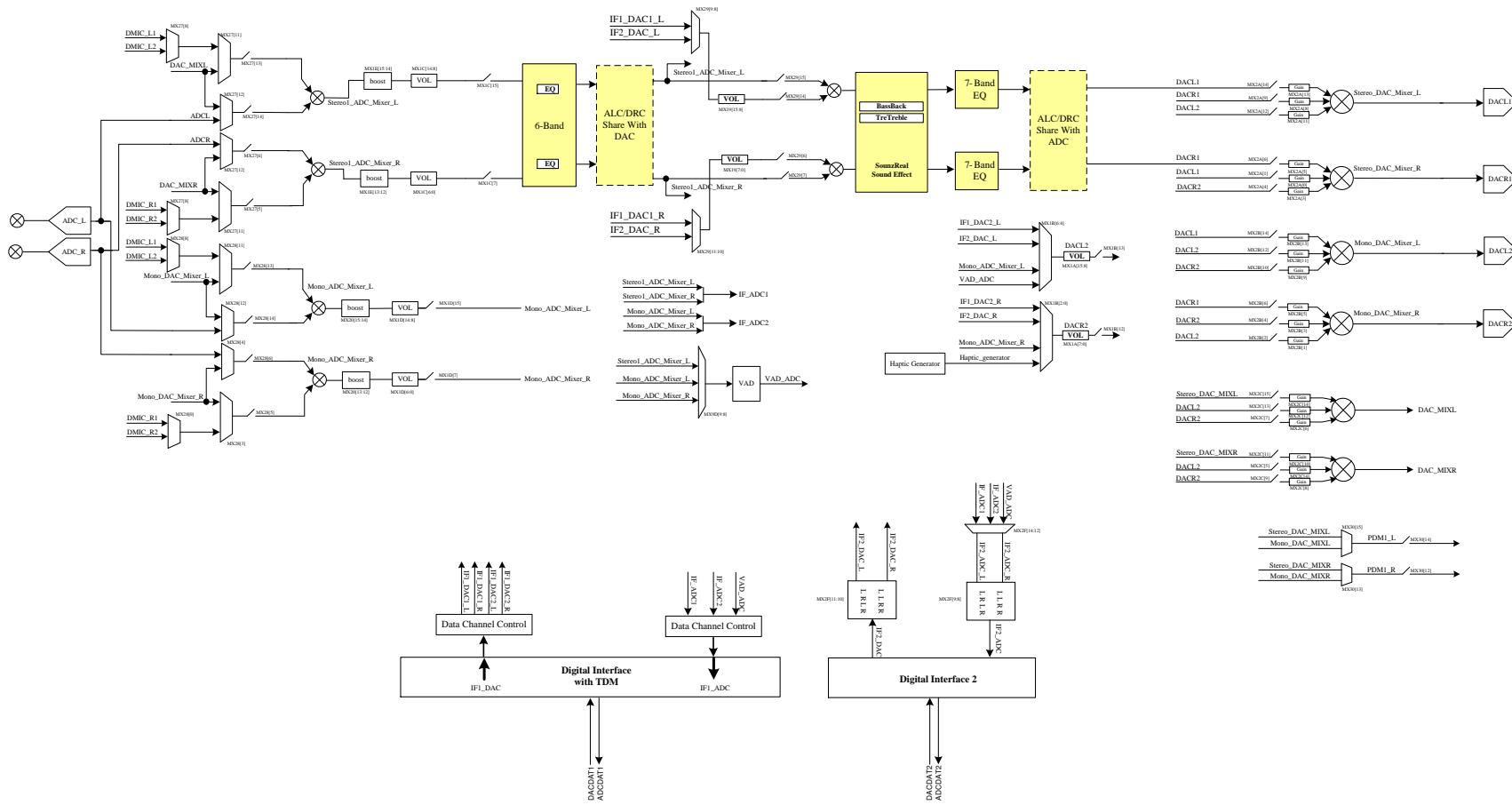


Figure 3. Digital Mixer Path

6. Pin Assignments

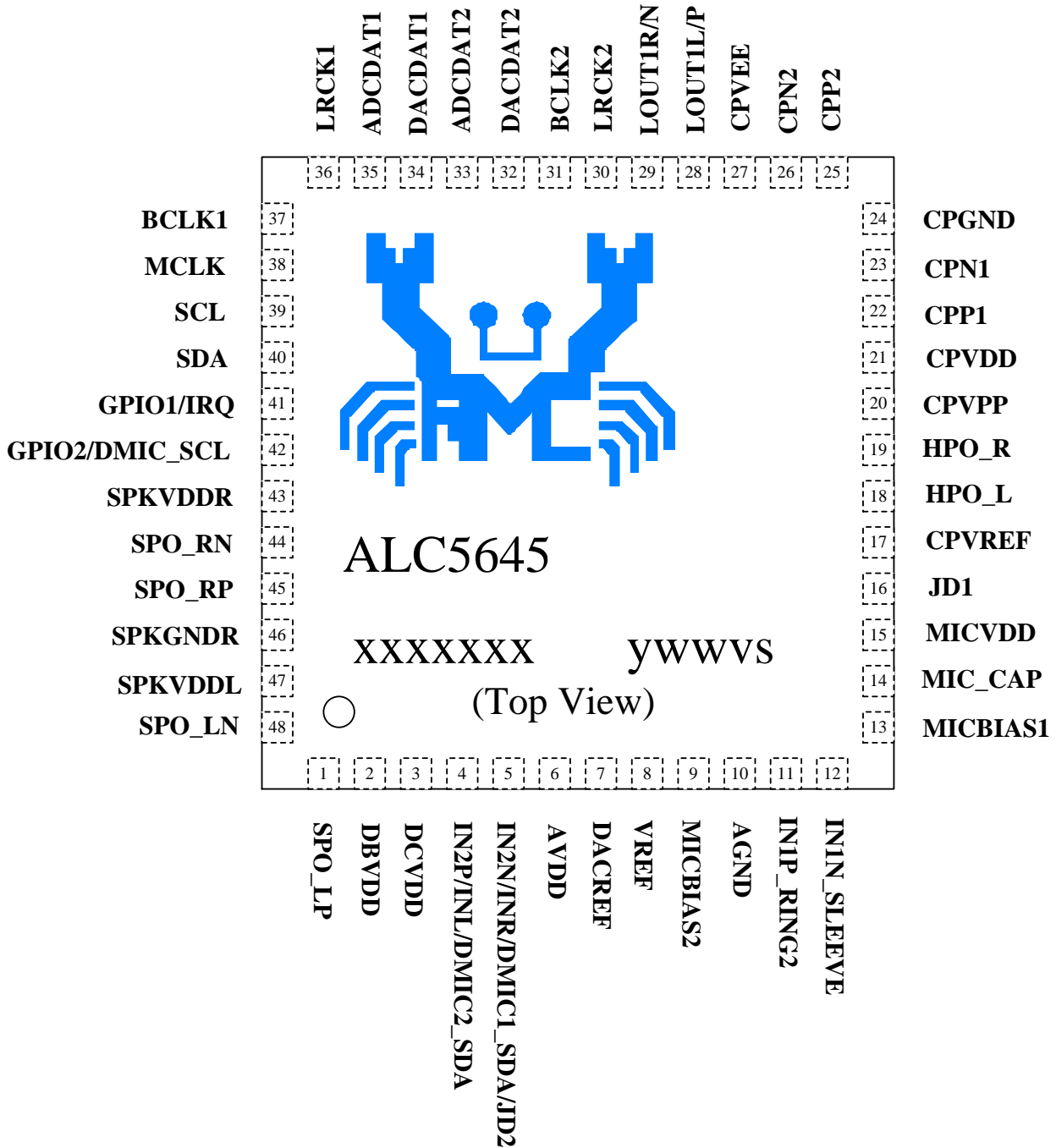


Figure 4. Pin Assignments

7. Pin Descriptions

7.1. Digital I/O Pins

Table 1. Digital I/O Pins

Name	Type	Pin	Description	Characteristic Definition
DACDAT1	I	34	First I2S interface serial data input	Schmitt trigger ($V_{IL}=0.35*DBVDD$, $V_{IH}=0.65*DBVDD$)
ADCDAT1	O	35	First I2S interface serial data output	$V_{OL}=0.1*DBVDD$, $V_{OH}=0.9*DBVDD$
BCLK1	I/O	37	First I2S interface serial bit clock	Master: $V_{OL}=0.1*DBVDD$, $V_{OH}=0.9*DBVDD$ Slave: Schmitt trigger ($V_{IL}=0.35*DBVDD$, $V_{IH}=0.65*DBVDD$)
LRCK1	I/O	36	First I2S interface synchronous signal	Master: $V_{OL}=0.1*DBVDD$, $V_{OH}=0.9*DBVDD$ Slave: Schmitt trigger ($V_{IL}=0.35*DBVDD$, $V_{IH}=0.65*DBVDD$)
DACDAT2	I	32	Multi-function pin: Second I2S interface serial data input GPIO function Digital microphone 1 data input	Schmitt trigger ($V_{IL}=0.35*DBVDD$, $V_{IH}=0.65*DBVDD$)
ADCDAT2	O	33	Multi-function pin: Second I2S interface serial data output GPIO function Digital microphone 2 data input	$V_{OL}=0.1*DBVDD$, $V_{OH}=0.9*DBVDD$
BCLK2	I/O	31	Multi-function pin: Second I2S interface serial bit clock GPIO function	Master: $V_{OL}=0.1*DBVDD$, $V_{OH}=0.9*DBVDD$ Slave: Schmitt trigger ($V_{IL}=0.35*DBVDD$, $V_{IH}=0.65*DBVDD$)
LRCK2	I/O	30	Multi-function pin: Second I2S interface synchronous signal GPIO function	Master: $V_{OL}=0.1*DBVDD$, $V_{OH}=0.9*DBVDD$ Slave: Schmitt trigger ($V_{IL}=0.35*DBVDD$, $V_{IH}=0.65*DBVDD$)
SDA	I/O	40	I2C interface serial data	Open drain structure
SCL	I	39	I2C interface clock input	Schmitt trigger
MCLK	I	38	I2S interface master clock input	Schmitt trigger ($V_{IL}=0.35*DBVDD$, $V_{IH}=0.65*DBVDD$)
GPIO1/IRQ	I/O	41	Multi-function pin: General purpose input and output Interrupt output	Output: $V_{OL}=0.1*DBVDD$, $V_{OH}=0.9*DBVDD$ Input: Schmitt trigger
GPIO2/ DMIC_SCL	I/O	42	Multi-function pin: General purpose input and output Digital microphone clock output	Output: $V_{OL}=0.1*DBVDD$, $V_{OH}=0.9*DBVDD$ Input: Schmitt trigger
				Total: 13 Pins

7.2. Analog I/O Pins

Table 2. Analog I/O Pins

Name	Type	Pin	Description	Characteristic Definition
LOUTR/N	O	29	Line output type Single-ended output, right channel Differential output, negative channel	Analog output
LOUTL/P	O	28	Line output type Single-ended output, left channel Differential output, positive channel	Analog output
IN2P/INL1	I	4	Multi-function pin: Positive differential input for analog microphone 2 Left channel line input Digital microphone 2 data input	Analog input Digital input
IN2N/INR1	I	5	Multi-function pin: Negative differential input for analog microphone 2 Right channel line input Second jack detection pin Digital microphone 1 data input	Analog input JD threshold: $V_{IL} = 0.2V$, $V_{IH} = 1.2V$ Digital input
IN1P_RING2	I	11	Analog microphone single end input 1	Analog input
IN1N_SLEEVE	I	12	Analog microphone single end input 1	Analog input
JD1	I	16	Analog jack detection function	Multi-level jack detection pin JD threshold: $V_{i1} = 1.485V$ $V_{i2} = 1.925V$ $V_{i3} = 2.7V$
HPO_R	O	19	Headphone amplifier output Right channel	Analog output
HPO_L	O	18	Headphone amplifier output Left channel	Analog output
SPO_LP	O	1	Speaker amplifier output Left differential positive output channel	Analog output
SPO_LN	O	48	Speaker amplifier output Left differential negative output channel	Analog output
SPO_RP	O	45	Speaker amplifier output Right differential positive output channel	Analog output
SPO_RN	O	44	Speaker amplifier output Right differential negative output channel	Analog output
				Total: 13 Pins

7.3. Filter/Reference

Table 3. Filter/Reference

Name	Type	Pin	Description	Characteristic Definition
MICBIAS1	O	13	Bias voltage output for microphone	Programmable analog DC output
MIC_CAP	-	14	Microphone input reference voltage	4.7uF capacitor to analog ground
MICBIAS2	O	9	Bias voltage output for microphone	Programmable analog DC output
VREF	O	8	Internal reference voltage	4.7uF capacitor to analog ground
CPVREF	-	17	Headphone reference ground	Headphone ground
CPN1	-	23	First charge pump bucket capacitor	2.2uf capacitor to CPP1
CPP1	-	22	First charge pump bucket capacitor	2.2uf capacitor to CPN1
CPN2	-	26	Second charge pump bucket capacitor	2.2uf capacitor to CPP2
CPP2	-	25	Second charge pump bucket capacitor	2.2uf capacitor to CPN2
				Total: 9 Pins

7.4. Power/Ground

Table 4. Power/Ground

Name	Type	Pin	Description	Characteristic Definition
MICVDD	P	15	Analog power for MICBIAS	3.0V ~ 3.3V (Default 3.3V is recommended)
AVDD	P	6	Analog power	1.71V ~ 1.9V (Default 1.8V is recommended)
DACREF	P	7	Analog power	1.71V ~ 1.9V (Default 1.8V is recommended)
AGND	P	10	Analog ground	
CPVDD	P	21	Analog power for headphone charge pump	1.71V ~ 1.9V (Default 1.8V is recommended)
CPGND	P	24	Analog ground for headphone charge pump	
CPVEE	P	27	Charge pump negative voltage output	2.2uf capacitor to analog ground
CPVPP	P	20	Charge pump positive voltage output	2.2uf capacitor to analog ground
DCVDD	P	3	Digital power for digital core. (Internal LDO generated)	1.1V~1.3V
DBVDD	P	2	Digital power for digital I/O buffer	1.71V~3.3V (Default 1.8V is recommended)
SPKVDDL	P	47	Speaker AMP power for left channel	3.0V~5.0V (Default 5V or 3.3V)
SPKVDDR	P	43	Speaker AMP power for right channel	3.0V~5.0V (Default 5V or 3.3V)
SPKGND/ DGND	P	46, 49*	Speaker AMP ground Digital ground	Exposed-Pad
				Total: 13 Pins

8. Function Description

8.1. System Connection

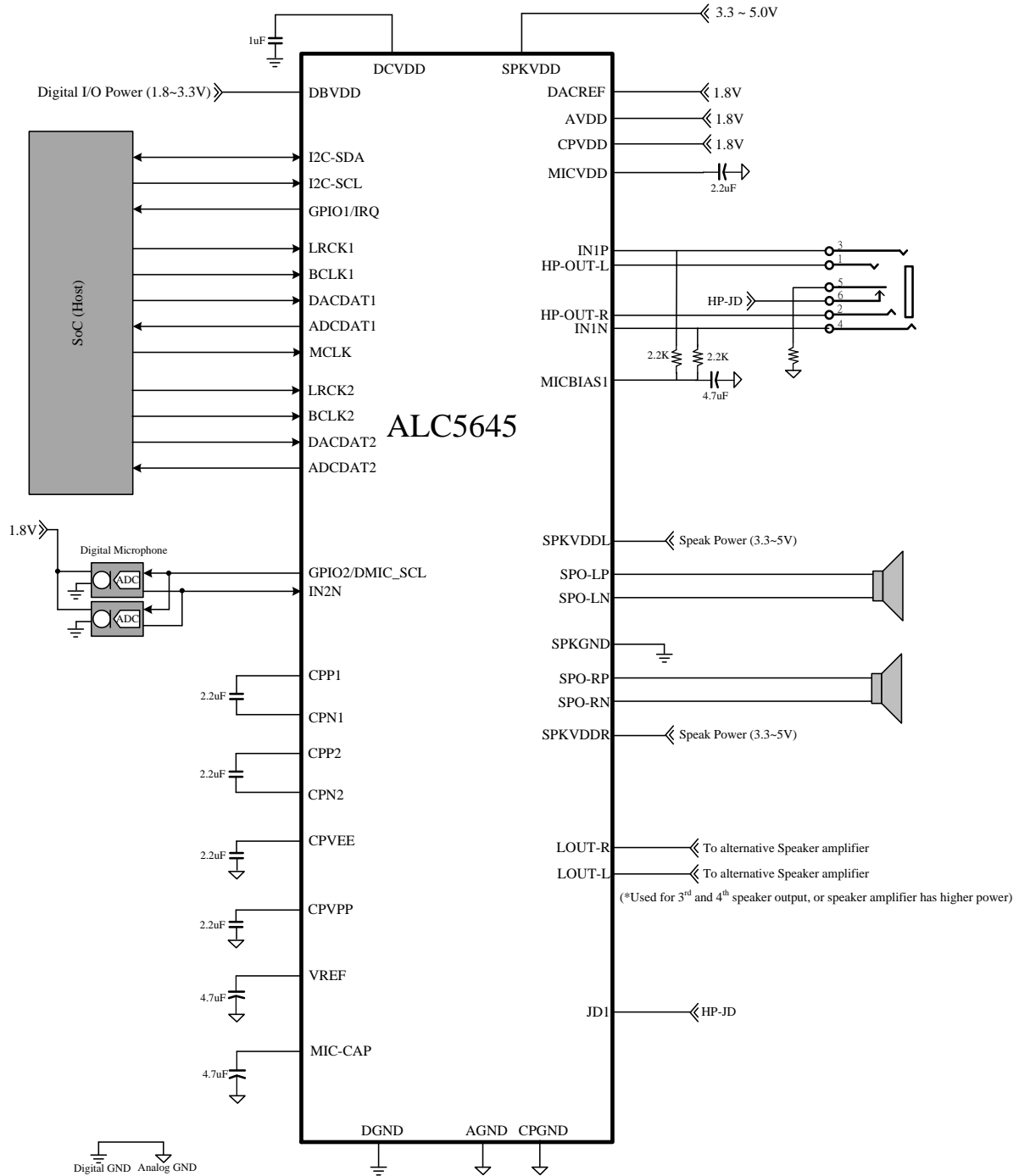


Figure 5. General System Connection

8.2. Power

There are different power types in ALC5645. DBVDD is for digital I/O power, DCVDD is for digital core power, AVDD and DACREF are for analog power, CPVDD is for charge pump power, MICVDD is for MICBIAS power and SPKVDD is for speaker amplifier power.

The power supplier limit condition are $DBVDD \geq DCVDD$ and $SPKVDD \geq MICVDD > AVDD = DACREF = CPVDD$, $AVDD > DCVDD$, and for the best performance, our design setting is shown as below.

Table 5. Power Supply for Best Performance

Power	DBVDD	DCVDD	AVDD	DACREF	CPVDD	MICVDD	SPKVDD
Setting	1.8V	1.2V	1.8V	1.8V	1.8V	3.3V	5.0V

*1.2V DCVDD was generated by internal LDO.

To prevent all power down leakage, there are three settings for power supply. At these conditions, the leakage will be smaller. The detail setting is shown as following table.

Table 6. Power Supply Condition for Power Down Leakage

Power	DBVDD	DCVDD	AVDD	DACREF	CPVDD	MICVDD	SPKVDD
Setting-1	Supplied	Supplied	Supplied	Supplied	Supplied	Supplied (or N/A)*	Supplied
Setting-2	N/A	N/A	N/A	N/A	N/A	N/A	Supplied
Setting-3	Supplied	Supplied	Supplied	Supplied	Supplied	Supplied (or N/A)*	N/A

“*” means MICVDD can be supplied by internal LDO and needs to turn-off when into power down mode.

8.3. Power Supply On/Off Sequence

To prevent pop noise and make sure function work normally, following power on and off sequence are recommended.

Case1: For SPKVDD is from battery:

Power On Sequence:

1. SPKVDD power supply on
2. DBVDD/AVDD/DACREF/CPVDD=1.8V power supply on
3. DBVDD power supply on (This step is required if DBVDD is supplied higher than 1.8V)
4. MICVDD power supply on (This step is required if MICVDD is supplied by external power)
5. Software starts to initialize ALC5645.

Power Off Sequence:

1. Power down all Codec function (Write 0x0000'h to register MX-00'h)
2. MICVDD power supply off (If MICVDD is supplied by external power)
3. DBVDD power supply off (This step is required if DBVDD is supplied higher than 1.8V)
4. DBVDD/AVDD/DACREF/CPVDD power supply off
5. SPKVDD power supply off

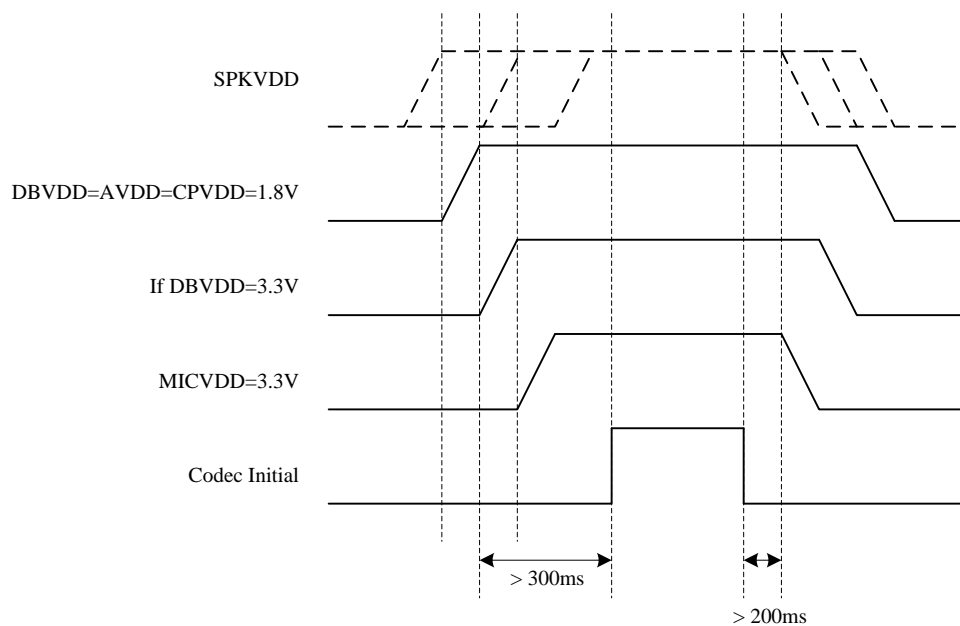
Case2: For SPKVDD is from PMIC:

Power On Sequence:

1. DBVDD/AVDD/DACREF/CPVDD=1.8V power supply on
2. DBVDD power supply on (This step is required if DBVDD is supplied higher than 1.8V)
3. MICVDD power supply on (This step is required if MICVDD is supplied by external power)
4. SPKVDD power supply on
5. Software starts to initialize ALC5645.

Power Off Sequence:

1. Power down all Codec function (Write 0x0000'h to register MX-00'h)
2. SPKVDD power supply off
3. MICVDD power supply off (If MICVDD is supplied by external power)
4. DBVDD power supply on (This step is required if DBVDD is supplied higher than 1.8V)
5. DBVDD/AVDD/DACREF/CPVDD power supply off


Figure 6. Power On/Off Timing

8.4. Reset

There are 2 types of reset operation: power on reset (POR) and register reset.

Table 7. Reset Operation

Reset Type	Trigger Condition	CODEC Response
POR	Monitor digital power supply voltage reach V_{POR}	Reset all hardware logic and all registers to default values.
Register Reset	Write MX-00h	Reset all registers to default values except some specify control registers and logic.

8.4.1. Power-On Reset (POR)

When powered on, DCVDD passes through the V_{POR} band of the ALC5645 ($V_{POR_ON} \sim V_{POR_OFF}$). A power on reset (POR) will generate an internal reset signal (POR reset 'LOW') to reset the whole chip.

Table 8. Power-On Reset Voltage

Symbol	Min	Typical	Max	Unit
V_{POR_ON}	-	0.8	-	V
V_{POR_OFF}	-	0.52	-	V

Note:

1. V_{POR_OFF} must be below V_{POR_ON}
2. $T^{\circ}C = 25^{\circ}C$
3. When DCVDD is supplied 1.2V

8.4.2. Software Reset

When MX-00h is wrote, all registers become to default value.

8.5. Clocking

The system clock of ALC5645 can be selected from MCLK or PLL. MCLK is always provided externally while the reference clock of PLL can be selected from MCLK, BCLK1/2. The driver should arrange the clock of each block and setup each divider.

The $\text{Clk_sys_i2s1}=256*F_s$ provides clocks into stereo DAC/ADC filter that can be selected from MCLK or PLL. Refer to Figure 5. Audio SYSCLK

The $\text{Clk_sys_i2s2}=256*F_s$ provides clocks into mono DAC/ADC filter that can be selected from MCLK, PLL, refer to Figure 5. Audio SYSCLK

When enable ASRC (Asynchronous Sample Rate Converter) function, the clock sources from MCLK and BCLK1 (or BCLK2) are allowed to be asynchronous. The Realtek ASRC technology can ensure data accuracy and keep audio performance under clock source asynchronous.

When ALC5645 at master mode, the clock source from MCLK will be divided and be sent to external device. The ratio of BCLK and LRCK can set by register – MX-73/77.

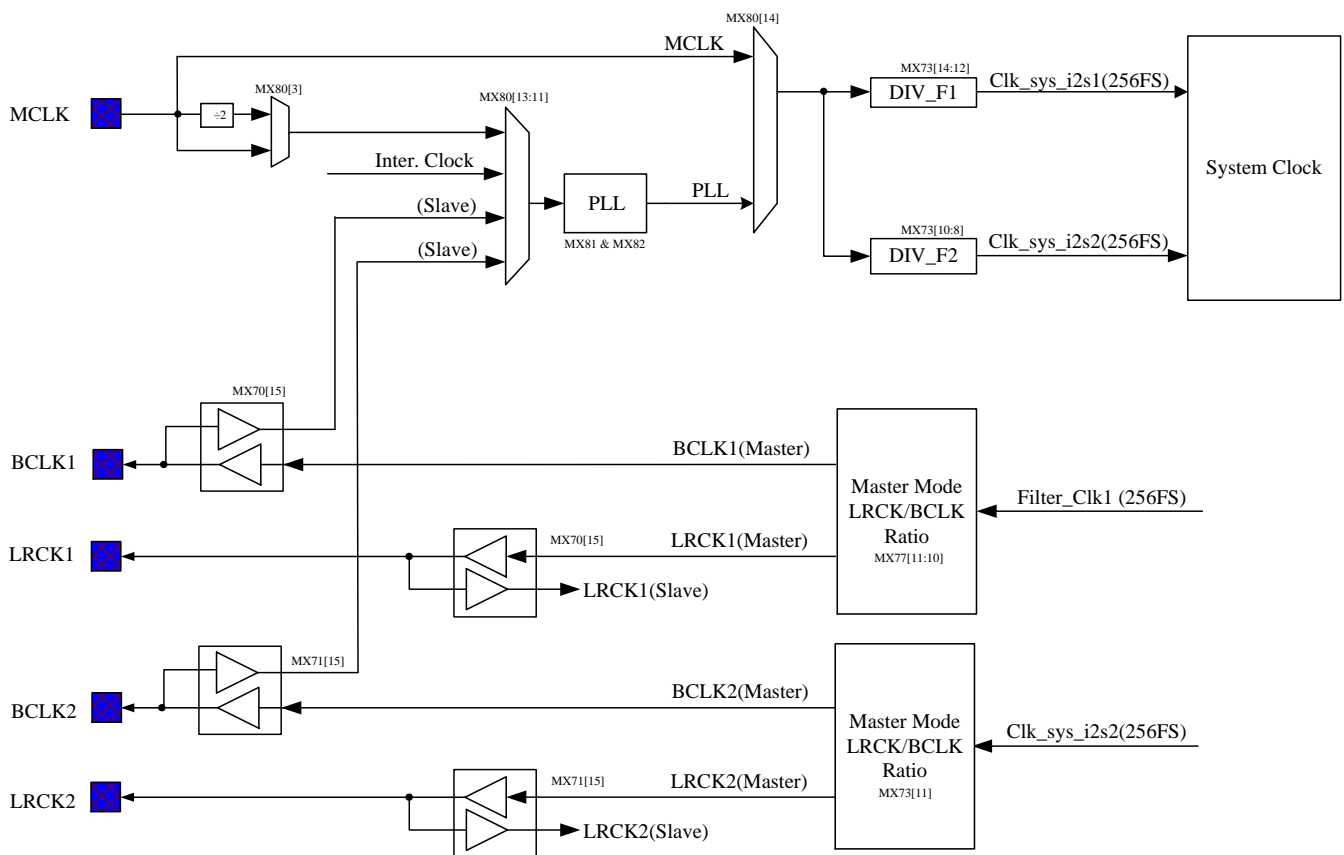


Figure 7. Audio Clock Tree

8.5.1. Phase-Locked Loop

A Phase-Locked Loop (PLL) is used to provide a flexible input clock from 2.048MHz to 40MHz. The source of the PLL can be set to MCLK, BCLK1 or BCLK2 by setting register.

The S/W driver can set up the PLL to output a frequency to match the requirement of system clock.

The PLL transmit formula as below:

$$F_{OUT} = (MCLK * (N+2)) / ((M+2) * (K+2)) \{ \text{Typical } K=2 \}$$

Table 9. Clock Setting Table for 48K (Unit: MHz)

MCLK	N	M	F _{VCO}	K	F _{OUT}
13	66	7	98.222	2	24.555
3.6864	78	1	98.304	2	24.576
2.048	94	0	98.304	2	24.576
4.096	70	1	98.304	2	24.576
12	80	8	98.4	2	24.6
15.36	81	11	98.068	2	24.517
16	78	11	98.462	2	24.615
19.2	80	14	98.4	2	24.6
19.68	78	14	98.4	2	24.6
24	39	8	98.4	2	24.6

Table 10. Clock Setting Table for 44.1K (Unit: MHz)

MCLK	N	M	F _{VCO}	K	F _{OUT}
13	68	8	91	2	22.75
3.6864	72	1	90.931	2	22.733
2.048	86	0	90.112	2	22.528
4.096	64	1	90.112	2	22.528
12	66	7	90.667	2	22.667
15.36	63	9	90.764	2	22.691
16	66	10	90.667	2	22.667
19.2	64	12	90.514	2	22.629
19.68	67	13	90.528	2	22.632
24	62	15	90.352	2	22.588

8.5.2. I²C and Two I²S/PCM Interface

The ALC5645 supports I²C for the digital control interface, and has two I²S/PCM for digital data interface. These two I²S/PCM audio digital interfaces are used to send data to 4 DACs or to receive data from a stereo ADC. These two I²S/PCM audio digital interfaces can be configured to Master mode or Slave mode.

Master Mode

Under master mode, BCLK and LRCK are configured as output. If I2S SYSCLK is selected from MCLK source, sel_sysclk1 (MX-80[14]) should set as 0'b. If selected from PLL output, sel_sysclk1 should set as 1'b. PLL's source is suggested to provide frequency from 2.048MHz to 40MHz. The driver should set each divider (MX-77 & MX-73) to arrange the clock distribution. Refer to Figure6. Audio Clock Tree, for details.

Table 11. The relative of SYSCLK/BCLK/LRCK

Register Settings	MCLK	BCLK	LRCK
MX-77[11:10]=00'b, I2S1 MX-73[11]=0'b, I2S2	256*FS=12.288MHz	32*FS=1.536MHz	FS=48KHz
MX-77[11:10]=11'b, I2S1 MX-73[11]=1'b, I2S2	256*FS=12.288MHz	64*FS=3.072MHz	FS=48KHz
MX-77[11:10]=00'b, I2S1 MX-73[11]=0'b, I2S2	256*FS=11.2896MHz	32*FS=1.4112MHz	FS=44.1KHz
MX-77[11:10]=11'b, I2S1 MX-73[11]=1'b, I2S2	256*FS=11.2896MHz	64*FS=2.8224MHz	FS=44.1KHz

Example for master mode:

Target format:

Sample Rate: 48 KHz

Channel Length: 32 bits

LRCK=48KHz

BCLK=3.072MHz (64 * 48KHz)

MCLK clock request:

MCLK=12.288MHz (256 * 48 KHz)

Register settings:

Set MX-FA[0] to "1" // For MCLK input clock getting control

Set MX-61[15] to "1" // Enable I2S-1

Set MX-70[15] to "0" // Enable Master mode

Set MX-77[11:10] to "11" // Select 64*FS for BCLK in master mode

Set MX-73[14:12] to "000" // Select I2S-1 pre-divider

Slave Mode

Under slave mode BCLK and LRCK are configured as input. The SYSCLK can be input from MCLK, and BCLK can be synchronous or asynchronous to MCLK. If the SYSCLK is selected from BCLK, the internal PLL should generate 256*FS as internal system clock. And the driver should set each divider to arrange the clock distribution. Refer to Figure6. Audio Clock Tree, for details.

If MCLK and BCLK are asynchronous, it needs to turn on ASRC function to process asynchronous data. As Figure 6 shown, the MCLK is from external oscillator that clock is no relation (or asynchronous) with

SOC and BT or 3G BaseBand. SOC and BT can directly connect to Codec and let Codec as slave mode and SOC/BT as master mode. Then turn-on Codec ASRC function will no data bit loss on transmitting and receiving.

For the clock requirement of ASRC function, the system clock (MCLK) needs to higher than $512 \cdot FS$ (FS is sample rate). If the MCLK is lower than $512 \cdot FS$, it can use internal PLL to generate $512 \cdot FS$ clock for using.

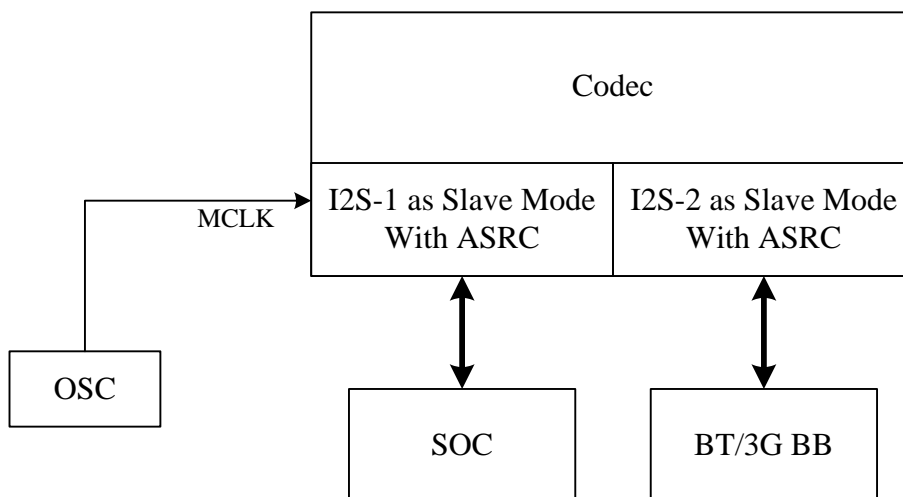


Figure 8. System Connection for ASRC Function

Table 12. Register Settings for ASRC Function on Slave Mode

Condition: Codec as Slave Mode MCLK = 12MHz Frame Rate = 64*FS Target Sample Rate (FS) = 48KHz		
Item	Register Settings	Note
PLL Settings	MX-81 = 0x1481'h MX-82 = 0x5000'h	PLL settings to generate 512*FS (24.576MHz) for SYSCLK
I2S-1 to DAC1	MX-83 = 0x0C00'h MX-84 = 0x1000'h	For DAC1 playback ASRC settings
I2S-2 to DAC2	MX-83 = 0x1300'h MX-84 = 0x0220'h	For DAC2 playback ASRC settings
AMIC to Stereo ADC Filter to I2S-1	MX-83 = 0x0808'h MX-84 = 0x0001'h	For AMIC to Stereo ADC Filter record ASRC settings
AMIC to Mono ADC Filter to I2S-2	MX-83 = 0x1800'h MX-85 = 0x0022'h	For AMIC to Mono ADC Filter record ASRC settings
DMIC1 to Stereo ADC Filter to I2S-1	MX-83 = 0x0880'h MX-84 = 0x0001'h	For DMIC1 to Stereo ADC Filter record ASRC settings

8.6. Digital Data Interface

8.6.1. Two I²S/PCM Interface

The two I2S/PCM interface can be configured as master mode or slave mode. Four audio data formats are supported:

- PCM mode
- Left justified mode
- I²S mode
- TDM mode (Max. BCLK Rate is 12.288MHz)

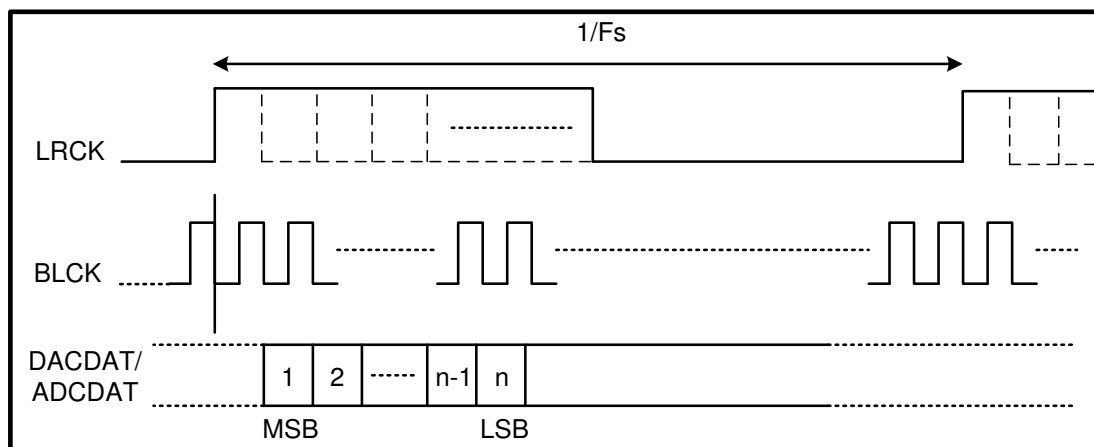


Figure 9. PCM MONO Data Mode A Format (BCLK POLARITY=0)

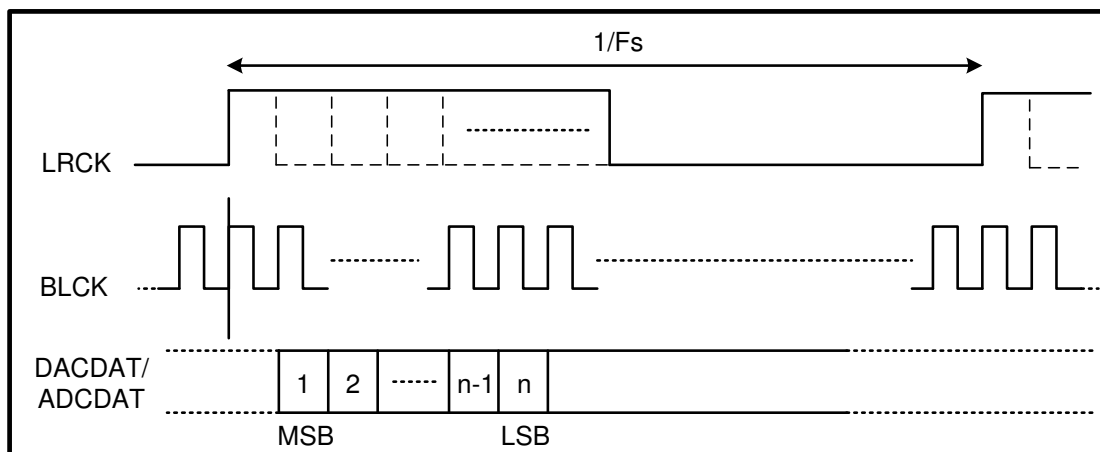


Figure 10. PCM MONO Data Mode A Format (BCLK POLARITY=1)

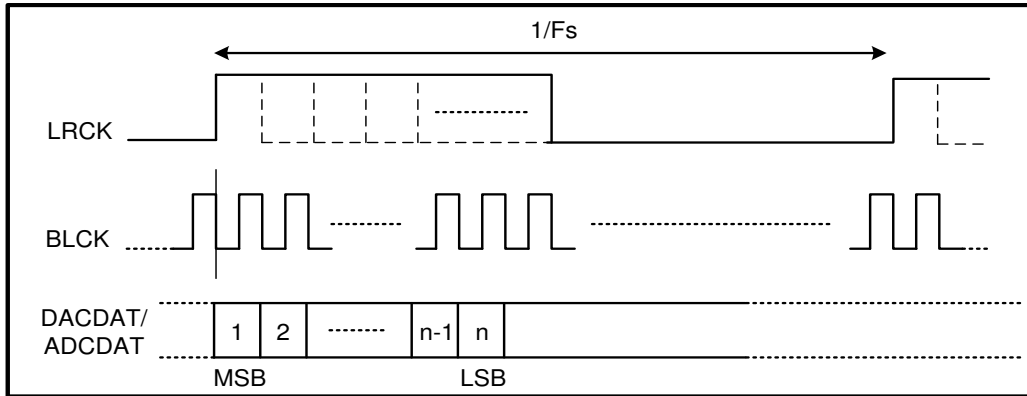


Figure 11. PCM MONO Data Mode B Format (BCLK POLARITY=0)

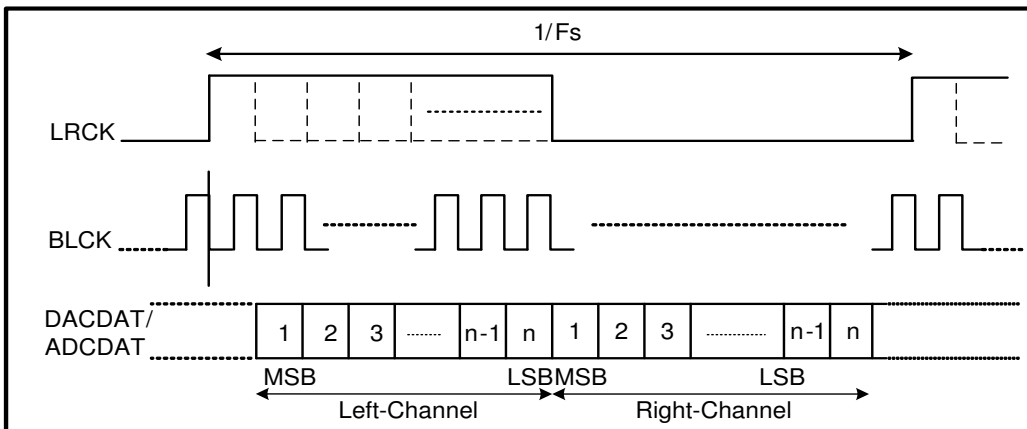


Figure 12. PCM Stereo Data Mode A Format (BCLK POLARITY=0)

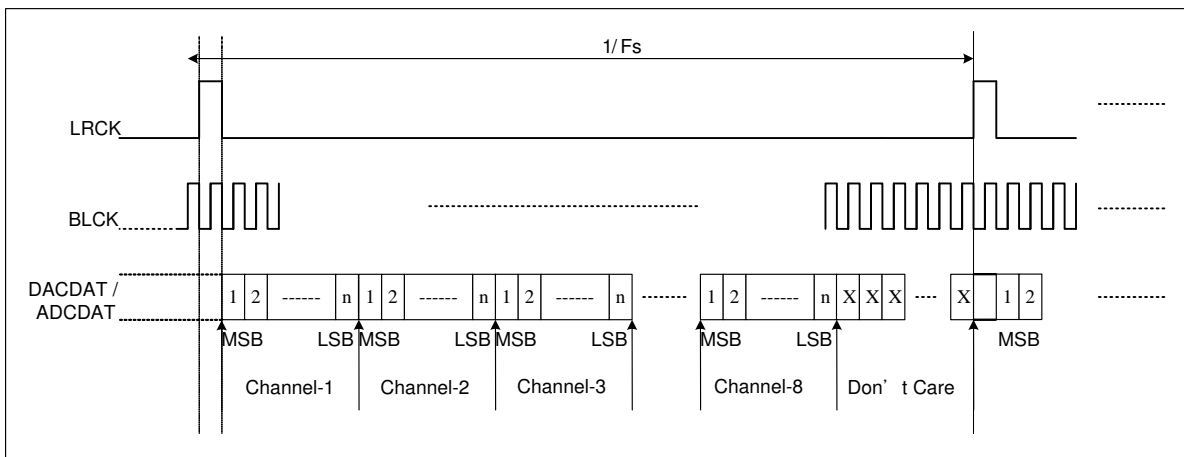


Figure 13. PCM TDM Data Mode A Format (BCLK POLARITY=0)

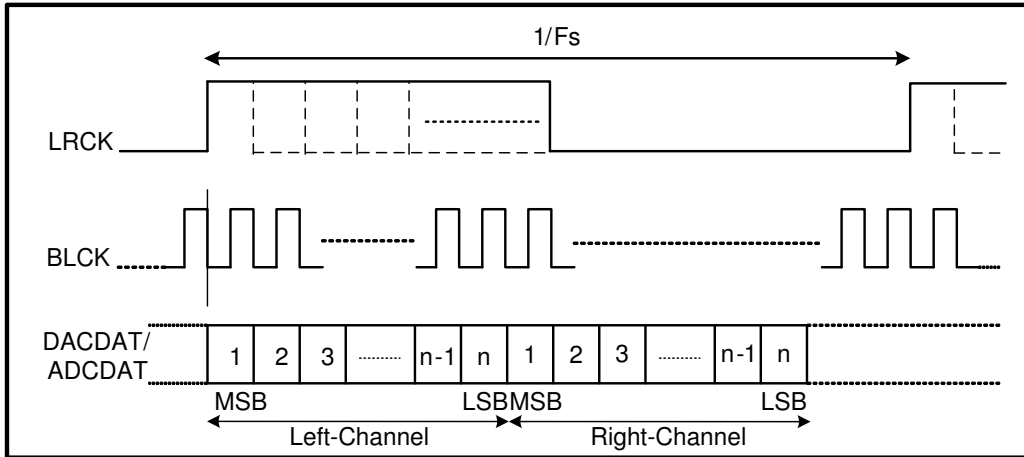


Figure 14. PCM Stereo Data Mode B Format (BCLK POLARITY=0)

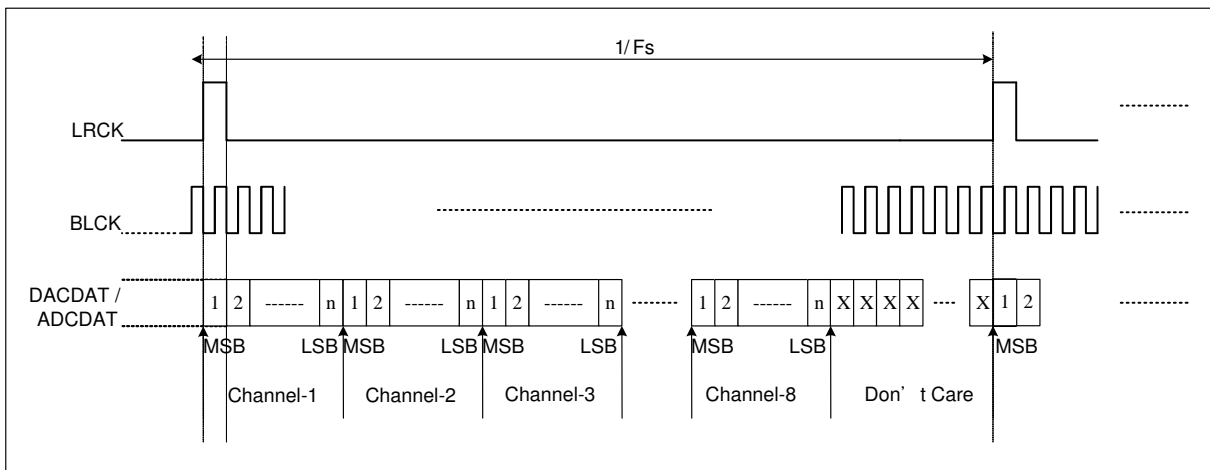


Figure 15. PCM TDM Data Mode B Format (BCLK POLARITY=0)

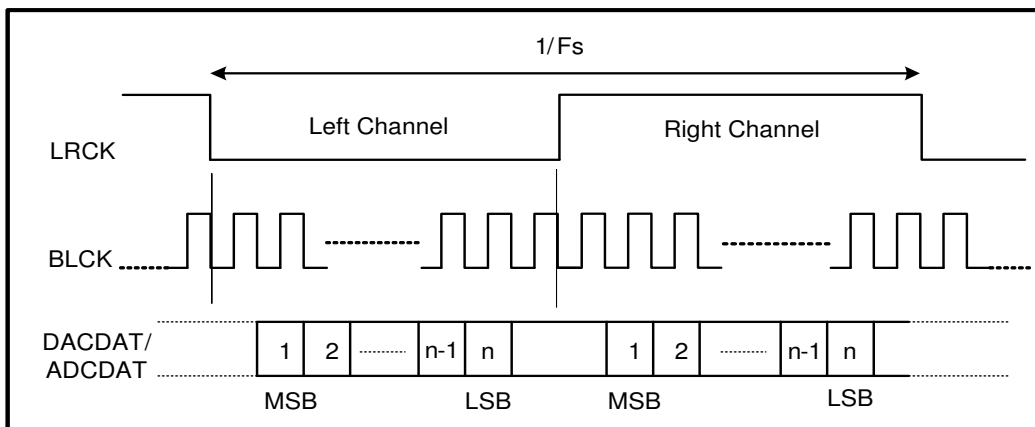


Figure 16. I²S Data Format (BCLK POLARITY=0)

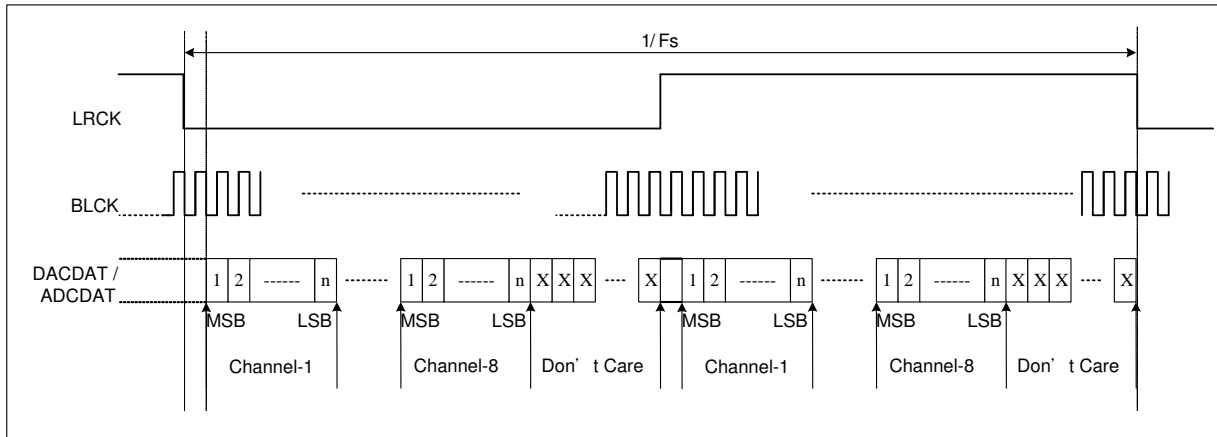


Figure 17. I²S TDM Data Format (BCLK POLARITY=0)

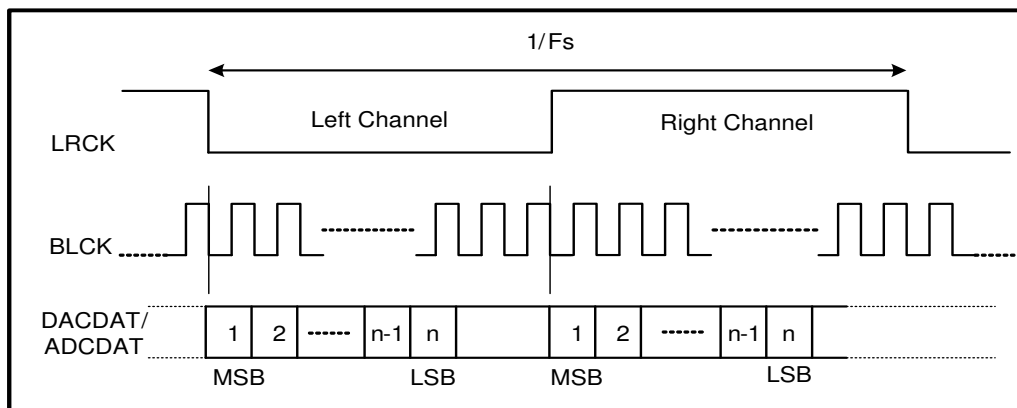


Figure 18. Left-Justified Data Format (BCLK POLARITY=0)

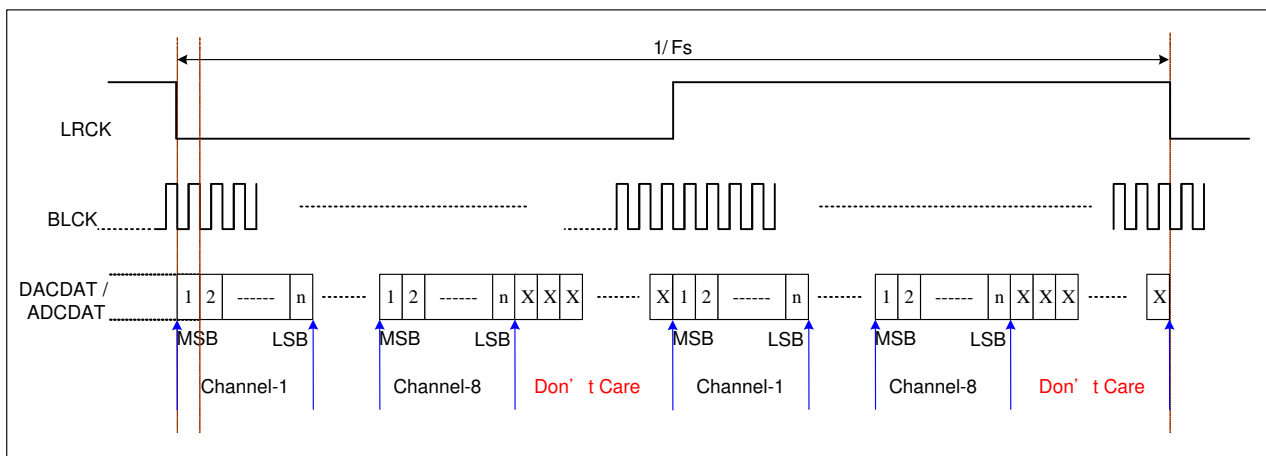


Figure 19. Left-Justified TDM Data Format (BCLK POLARITY=0)

8.7. Audio Data Path

The ALC5645 provides 4-channel analog DACs for playback and 2-channel analog ADCs for recording.

8.7.1. 2 Analog ADCs with 4-Channel Record Path

There are two analog ADCs and with up to 4-channel recording path. It can use two analog inputs to stereo analog ADC and stereo digital microphone inputs to reach 4 channel recording. Or use two digital microphone interfaces and 4 channel digital microphone data to reach 4 channel recording. The 4 channel data can through I2S1 TDM interface to host. The I2S1 interface supports TDM interface and up to 8-CH, 24-bit/CH recording.

The full scale input of analog ADC is around 0.55Vrms. In order to save power, the left and right analog ADC can be powered down separately by setting `pow_adc_l` (MX-61[2]) and `pow_adc_r` (MX-61[1]). And the volume control of the stereo ADC is also separately controlled by `ad_gain_l` (MX-1C[14:8]) and `ad_gain_r` (MX-1C[6:0]).

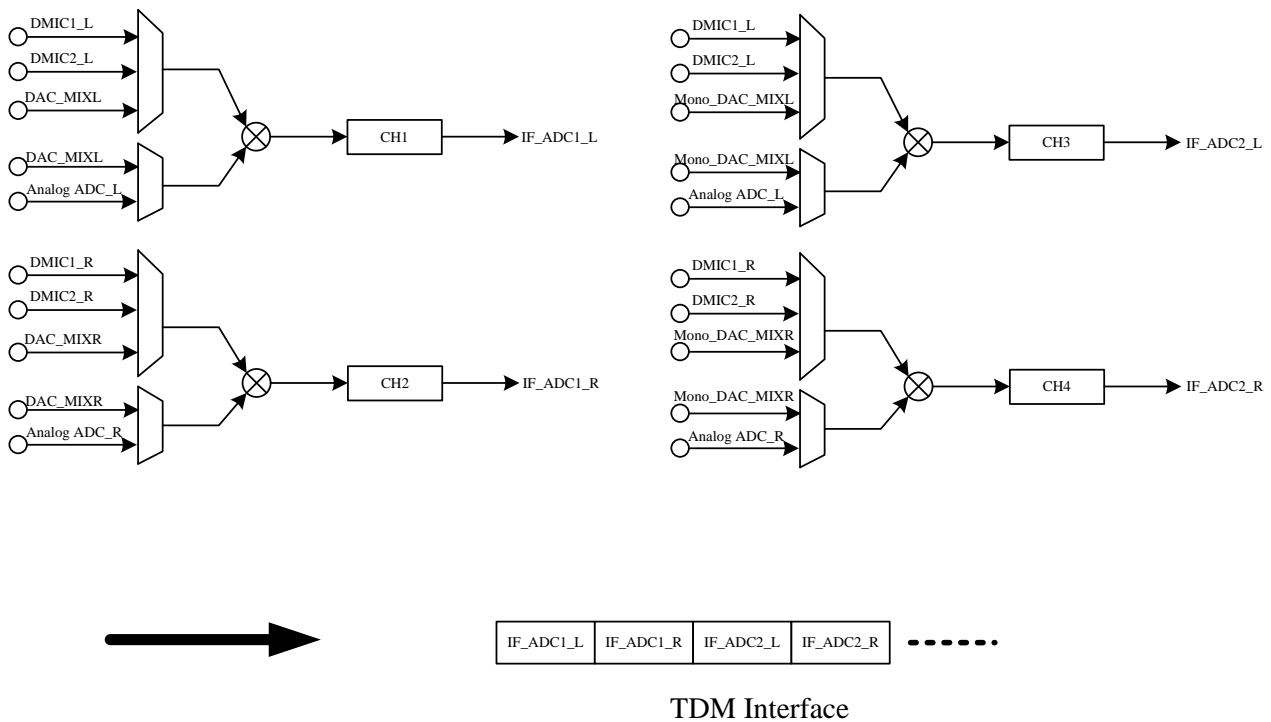


Figure 20. 4-Channel Recording Path

8.7.2. 4 DACs with 4-Channel Playback Path

There are four analog DACs and with up to 4 channel playback path. The 4 channel data can be selected from two I2S interfaces or first I2S TDM interface. And 4 analog DACs can output audio signal to speaker output, headphone output or line output.

The full scale output of analog DAC is around 1Vrms at line output port. In order to save power, the four analog DACs can be powered down separately by setting `pow_dac_l_1` (MX-61[12]), `pow_dac_r_1` (MX-61[11]), `pow_dac_l_2` (MX-61[7]) and `pow_dac_r_2` (MX-61[6]). And the digital volume control of the four DACs are also separately controlled by `vol_dac1_l` (MX-19[15:8]), `vol_dac1_r` (MX-19[7:0]), `vol_mono_dacl` (MX-1A[15:8]) and `vol_mono_dacr` (MX-1A[7:0]).

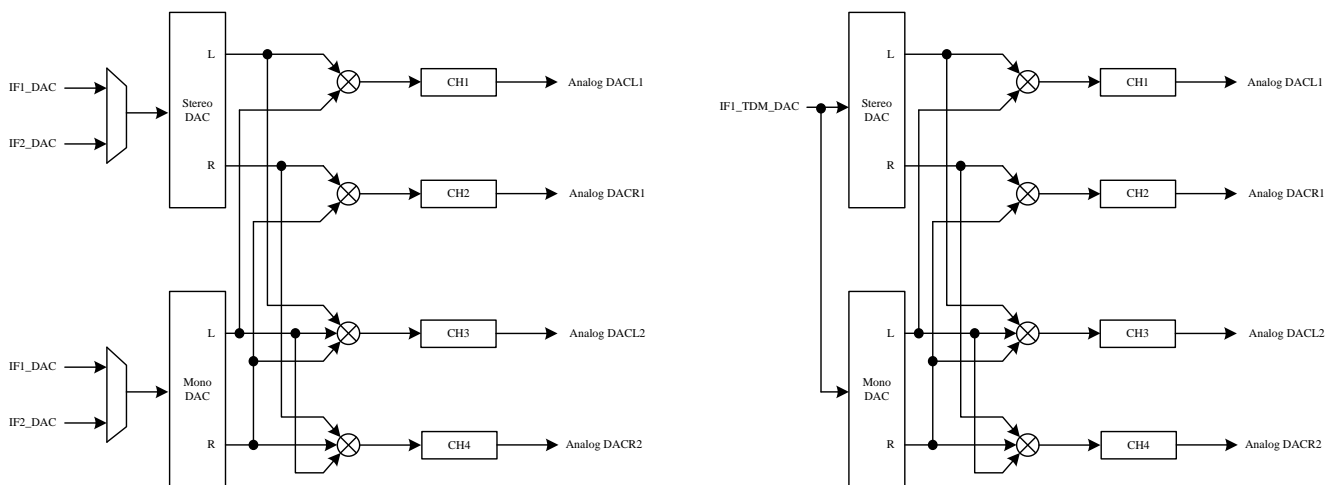


Figure 21. 4-Channel Playback Path

8.7.3. Mixers

The ALC5645 has digital and analog mixers build-in.

- **Output mixer - OUTMIXL/R**

The stereo analog output mixer can mix analog DAC output data and analog input data. The mixer output will feed to line output stage. Each input paths have dedicated mute and gain control in MX-4D/4E/4F/50 /51/52. The analog mixer also builds-in analog volume. The volume range is from +12dB to -34.5dB with 1.5dB per step.

- **Record mixer – RECMIXL/R**

The stereo analog mixer can mix analog input data and output mixer data. The mixer output will feed to analog ADC. Each input paths have dedicated mute control in MX-3B/3C/3D/3E.

- **HP mixer – HPMIXL/R**

The stereo analog mixer can mix analog DAC output data and analog input data. The mixer output will feed to headphone output stage. Each input paths have dedicated mute control in MX-3F/40/41 /42. The analog mixer also builds-in analog volume. The volume range is from +12dB to -34.5dB with 1.5dB per step.

- **Speaker mixer – SPKMIXL/R**

The stereo analog mixer can mix analog DAC output data and analog input data. The mixer output will feed to speaker amplifier. Each input paths have dedicated mute control in MX-46/47. The analog mixer also builds-in analog volume. The volume range is from +12dB to -34.5dB with 1.5dB per step.

- **Digital mixer**

There are ten digital mixers in ALC5645. Four digital mixers are assigned for ADC recording. These four mixers can mix analog line input, analog microphone input and digital microphone input then feed to I2S interface to external host. Another four digital mixers are assigned for DAC playback. These mixers can mix digital data from I2S interface or ADC data from external analog signal. The mixed data will output to analog DAC and output stage to drive external device. The other two mixers are used for DA-AD processing. The income data from two I2S interfaces (DACDAT), after do digital sound processing (EQ/ALC) then round to DA-AD mixers to recording mixer and feed to I2S interface (ADCDAT).

8.8. Analog Audio Input Port

The ALC5645 has two type analog input ports: microphone input and line input.

- **IN1P_RING2/IN1N_SLEEVE**

The port is a microphone type input port. The input port only support single-ended mode. The microphone input port build-in microphone boost gain. The low noise microphone bias also build-in in ALC5647, it provide analog microphone driving voltage. The microphone bias support short current detection function for push button detection. Multi-steps microphone boost gain set by sel_bst1 (MX-0A[15:12]) is easy to use for analog microphone compensation. MX-64[15] control bit used to power on/down the IN1P/N and MX-64[11] used to power on/down the microphone bias 1.

- **IN2P/N**

The IN2P/N is a dual type input port: analog microphone input and line input. Analog microphone input can be configured to differential input or single-ended input by MX-0D[6]. Multi-steps microphone boost gain set by sel_bst2 (MX-0D[11:8]) is easy to use for analog microphone compensation. MX-64[14] used to power on/down the IN2P/N.

If as line input function, IN2P will as left line input port and IN2N as right line input port. The line input port has dedicated volume control for tuning by MX-0F[12:8] and MX-0F[4:0]. MX-66[9:8] used to power on/down the line input port.

8.9. Analog Audio Output Port

The ALC5645 supports three type output ports:

- **SPO_L/R_P/N**

The speaker output of ALC5645 is a stereo BTL output with Class-D type amplifier.

The power of speaker amplifier is an individual power pin and higher than AVDD. So the input and output of speaker amplifier has a gain ratio to enlarge or reduce the income analog signal. The gain ratio setting can be controlled by fbgain_clsd (MX-A0[15:12]).

The input source of the speaker output port can be selected from analog input, SPKVOL, DAC output by setting MX-46/47.

The front stage of speaker output has gain control and volume control. For gain control, the range is from 0dB to -9dB and controlled by MX-46/47. For volume control, the range is from +12dB to -46.5dB with 1.5dB/step controlled by MX-01.

The pow_spkmixl (MX-65[13]) and pow_spkmixr (MX-65[12]) can be used to power on/off SPKMIXL and SPKMIXR. The pow_clsd (MX-61[0]) can be used to power on/off SPO_L/R_P/N.

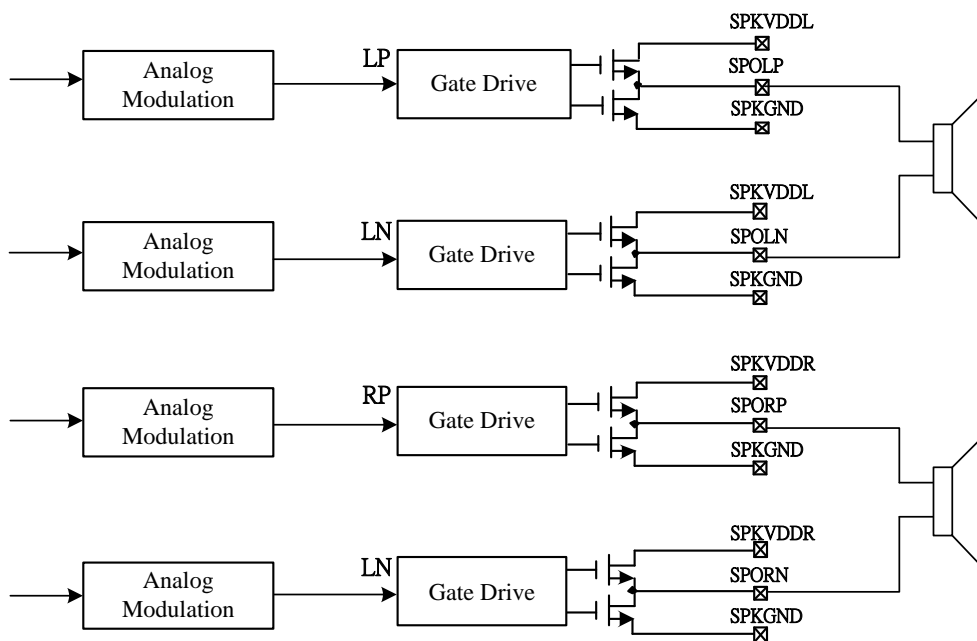


Figure 22. Stereo BTL Speaker Output

- **HPO_L/R**

The headphone output of ALC5645 is a stereo output with cap-free type headphone amplifier. It does not need to connect external capacitor and can connect to earphone device directly. The headphone output source can mix from output mixer (HPMIX) and DAC by setting MX-45. The front stage of headphone output has volume control and gain control. The volume range is from +12dB to -46.5dB

with 1.5dB/step by MX-02.

En_l_hp and en_r_hp (MX-63[7/6]) can be used to power on/off Headphone Amplifier, and pow_hpo_voll and pow_hpo_volr (MX-66[11/10]) can be used to power on/off headphone volume control. In addition, pow_pump_hp (MX-8E[3]) can be used to power on/off charge pump circuit for Headphone Amplifier.

- **Line_OUT_L/R**

The output type is line type output. The output is a stereo single ended output or mono differential output. The input can be selected from OUTMIX or DAC output by setting MX-53[15:12]. The front stage of LOUT output has gain control for attenuation. The gain control is 0dB or -6dB by MX-53[11].

8.10. Multi-Function Pins

There are eight multi-function pins in ALC5645. For different functions of each pin are controlled by register. You need to set the right register settings for each multi-function pins by your application.

- **GPIO1/IRQ – Pin 41**

The pin default is GPIO function. It can change to IRQ output, write MX-C0[15] to 1'b will switch to IRQ function.

- **GPIO2/DMIC_SCL – Pin 42**

The pin default is GPIO function. It can change to DMIC clock output, write MX-C0[14] to 1'b will switch to DMIC clock output function.

- **IN2P/INL – Pin 4**

The pin can as analog microphone positive input or as line input. If as analog microphone input function needs to power on the power – MX-64[14] & MX64[5]. If as analog line input function needs to power on the power – MX-66[9] & MX66[8].

- **IN2N/INR/DMIC2_DAT/JD2 – Pin 5**

There are four functions share this pin. For each function switching shows below:

Analog microphone input function, power on MX-64[14] & MX-64[5] and power off other functions.

Analog line input function, power on MX-66[9] & MX-66[8] and power off other functions.

Digital microphone input function:

1. Power down analog microphone input, line input and JD2 function
2. Mute IN2 to each analog mixer - (RECMIXLR/OUTMIXLR/HPMIXLR).
3. Turn on digital microphone function – MX-75[15] = 1'b

Jack detection function:

1. Power down analog microphone input, line input and digital microphone function.
2. Mute IN2 to each analog mixer - (RECMIXLR/OUTMIXLR/HPMIXLR).
3. Turn on JD2 power – MX-64[1] = 1'b

- **BCLK2/GPIO3 – Pin 31**

MX-C0[8] use to control pin31 is BCLK2 function or GPIO function.

- **LRCK2/GPIO4 – Pin 30**

MX-C0[8] use to control pin30 is LRCK2 function or GPIO function.

- **DACDAT2/GPIO5/DMIC1_SDA – Pin 32**

MX-C0[8] use to control pin32 is LRCK2 function or GPIO function.

MX-C0[7] use to control pin32 is GPIO function or DMIC_SDA1 function.

- **ADCDAT2/GPIO6/DMIC2_SDA – Pin 33**

MX-C0[8] use to control pin33 is LRCK2 function or GPIO function.

MX-C0[6] use to control pin33 is GPIO function or DMIC_SDA2 function.

8.11. DRC and AGC Function

The ALC5645 supports multi-band DRC. It uses crossover filter to separate low frequency band and high frequency band. The low frequency band signal will pass Bass DRC block then sum with Normal DRC signal. The corner frequency of crossover filter can be adjusted by register settings. Which range is from 6KHz to 50Hz on 48KHz sample rate. The following figure shows the function block.

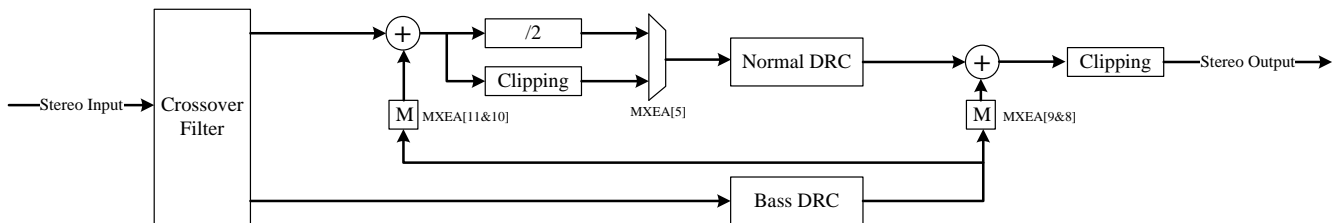


Figure 23. Multi-Band DRC Function Block

Crossover Filter Coefficient Calculation

Corner Frequency is F_c , Sample Rate is F_s .

First order low-pass-filter:

$$W_p = \tan((180 * F_c) / F_s)$$

$$A1 = \text{Hex}(((-) (W_p - 1) / (W_p + 1)) * (2^{22}))$$

$$A2 = 0$$

$$H0 = \text{Hex}((W_p / (W_p + 1)) * (2^{22}))$$

First order high-pass-filter:

$$W_p = \tan((180 * F_c) / F_s)$$

$$A1 = \text{Hex}(((-) (W_p - 1) / (W_p + 1)) * (2^{22}))$$

$$A2 = 0$$

$$H0 = \text{Hex}((1 / (W_p + 1)) * (2^{22}))$$

Second order low-pass-filter:

$$W_p = \tan((180 * F_c) / F_s)$$

$$A1 = \text{Hex}(((-) (2 * (W_p^2 - 1)) / (W_p^2 + \sqrt{2} * W_p + 1)) * (2^{22}))$$

$$A2 = \text{Hex}(((-) (W_p^2 - \sqrt{2} + 1) / (W_p^2 + \sqrt{2} * W_p + 1)) * (2^{22}))$$

$$H0 = \text{Hex}((W_p^2 / (W_p^2 + \sqrt{2} * W_p + 1)) * (2^{22}))$$

Second order high-pass-filter:

$$W_p = \tan((180 * F_c) / F_s)$$

$$A1 = \text{Hex}(((-) (2 * (W_p^2 - 1)) / (W_p^2 + \sqrt{2} * W_p + 1)) * (2^{22}))$$

$$A2 = \text{Hex}(((-) (W_p^2 - \sqrt{2} + 1) / (W_p^2 + \sqrt{2} * W_p + 1)) * (2^{22}))$$

$$H0 = \text{Hex}((1 / (W_p^2 + \sqrt{2} * W_p + 1)) * (2^{22}))$$

The Dynamic Range Controller (DRC) dynamically adjusts the input signal and let the output signal achieve the target level. The ALC5645 supports playback DRC for DAC path, and the DRC can also be

used as AGC(Auto Gain Controller) for ADC path. The control register is at MX-B4[15:14]. The function block is shown as below. The signal input pass through the Pre-Gain first, then DRC volume and Post-Gain then output. The Pre-Gain is use to enlarge the input signal. The DRC volume is use to attenuate the signal after detected by DRC. The Post-Gain is use to fine tune the signal after pass DRC tuning.

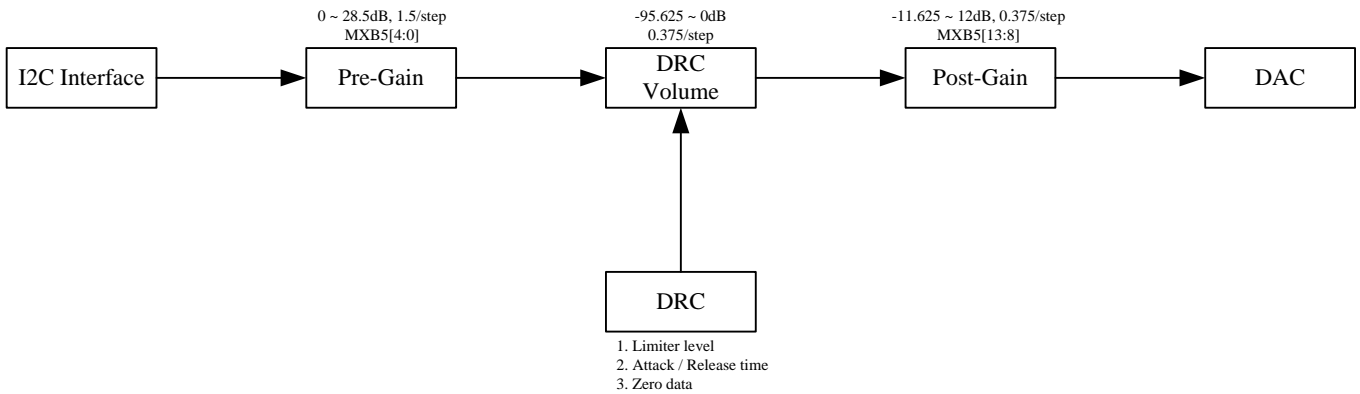


Figure 24. DAC DRC Function Block

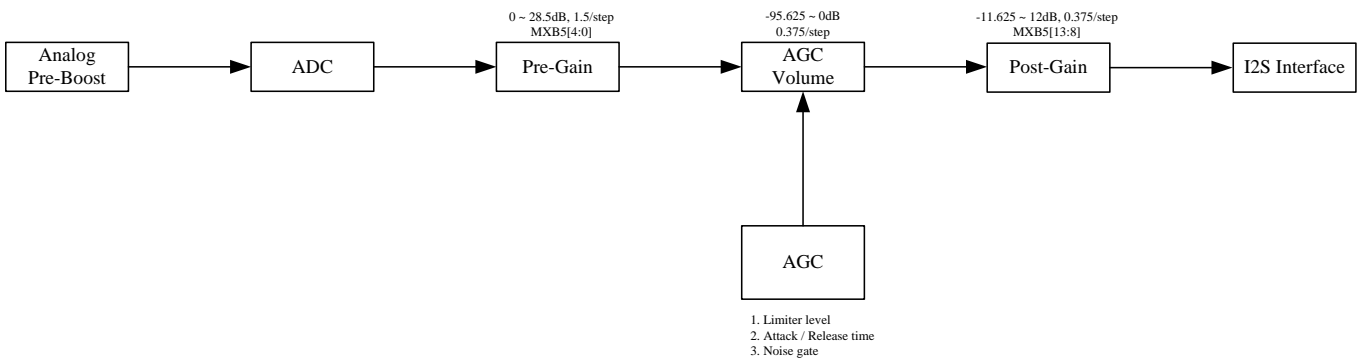


Figure 25. ADC AGC Function Block

Playback/Recording Mode:

For DAC playback or ADC recording mode, when the input signal exceeds target threshold, the signal will decrease “DRC/AGC Digital Volume” (0.375dB/step at every zero-crossing) until drop to target level then keep the digital volume. When input signal is below the target threshold, the signal will step-up “DRC/AGC Digital Volume” (0.375dB/step every zero-crossing) until return to original level. If want to return to the target level, need to set the pre-gain to achieve.

Fine tune parameters:

- Limiter Threshold: 0 ~ -46.5dB, 1.5dB/step, MX-B7[5:0]
- Attack Rate: $T=(4*2^n)/\text{sample rate}$, $n = \text{MX-B4}[12:8]$
- Recovery Rate: $T=(4*2^n)/\text{sample rate}$, $n = \text{MX-B4}[4:0]$

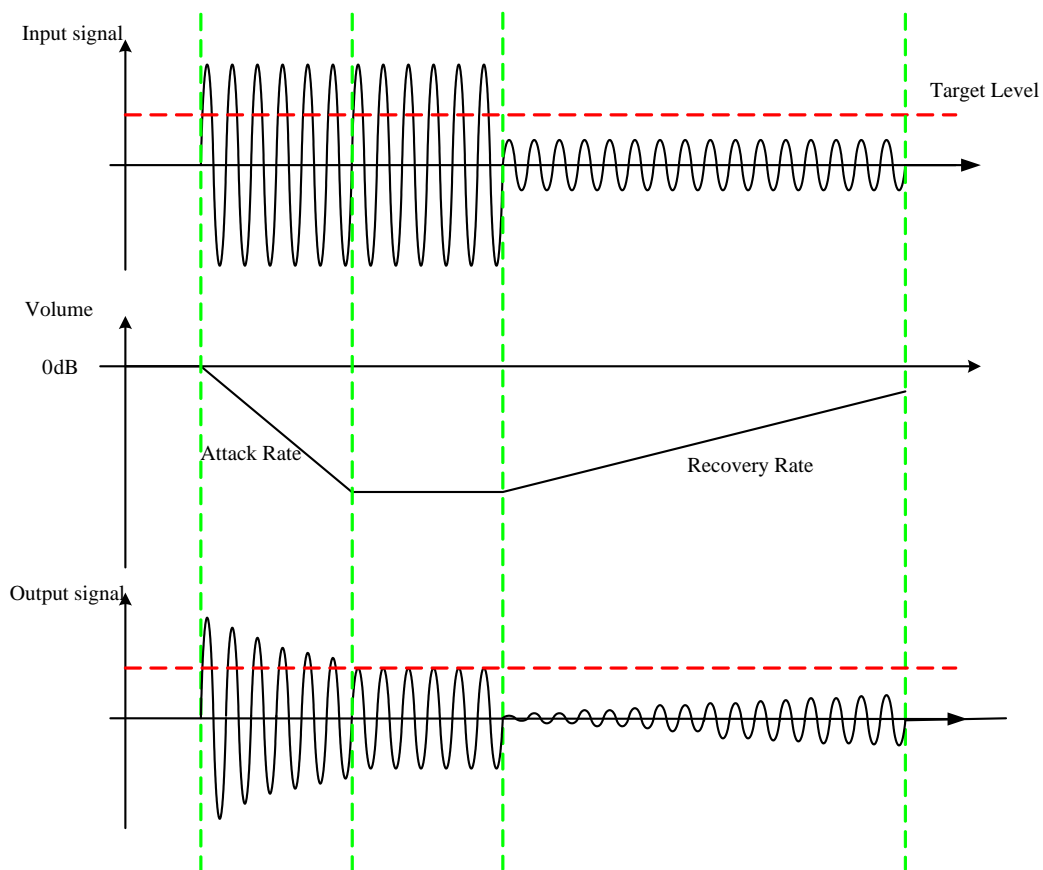


Figure 26. DRC/AGC for Playback/Recording Mode

Noise Gate Mode:

The Noise Gate Function is used to reduce the noise floor for DAC path or ADC path. When input signal is below noise gate level, the input signal will be reduced by DRC/AGC volume in order to suppress the background noise. The reducing level can be set by register. And when input signal is above noise gate, the input signal will be boosted to target level.

Fine tune parameters:

- Noise Gate Threshold: -36 ~ -82.5dB, 1.5dB/step, MX-B6[4:0]
- Noise Gate Attack Rate: $T=(4*2^n)/\text{sample rate}$, $n = \text{PR-05}[4:0]$
- Noise Gate Recovery Rate: $T=(4*2^n)/\text{sample rate}$, $n = \text{PR-02}[12:8]$
- Reducing Noise Level: 0 ~ 45dB, 3dB/step, MX-B6[15:12]

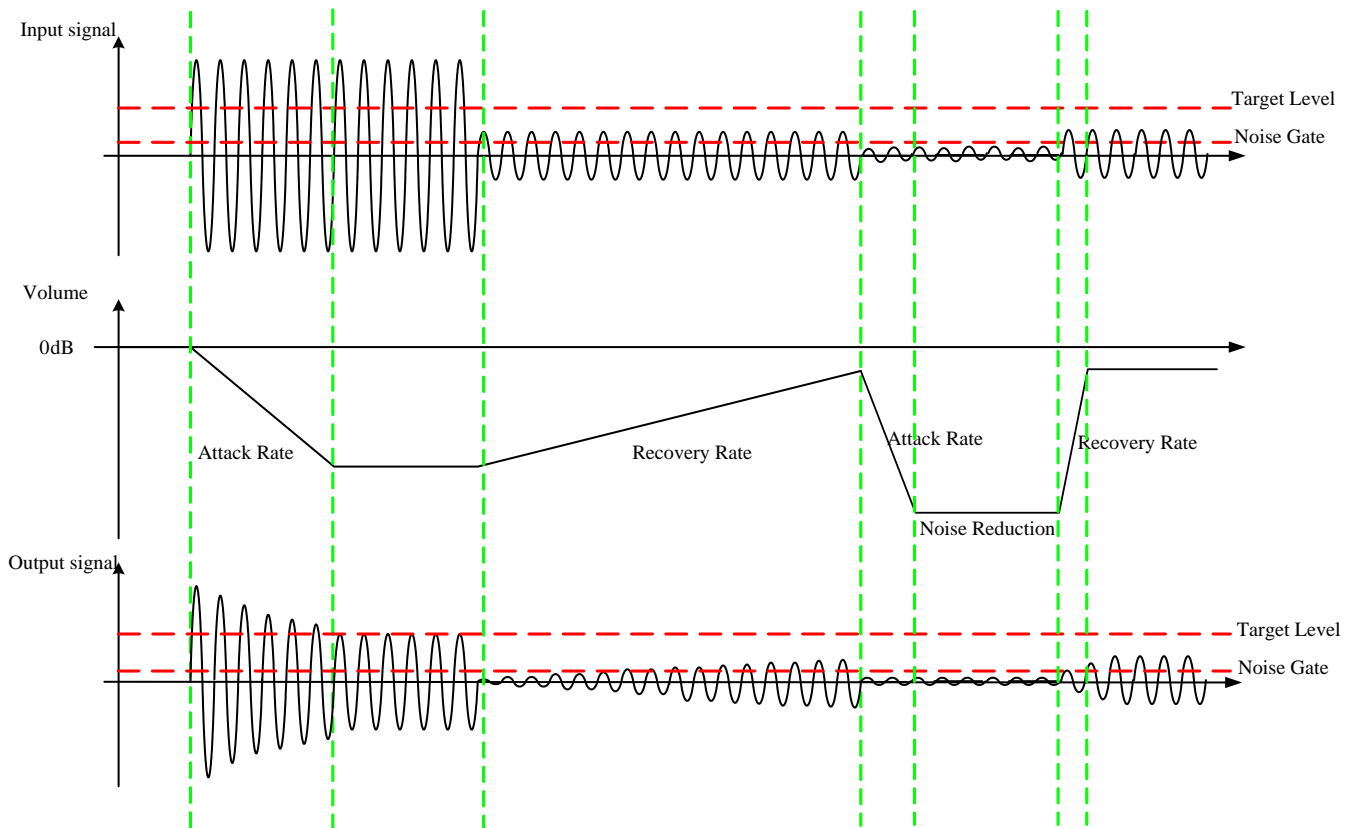


Figure 27. DRC/AGC for Noise Gate Mode

8.12. SounzReal™ Post-Processing

The Realtek's SounzReal™ Post-Processing is composed of:

- TruTreble
- BassBack

8.13. Equalizer Block

The equalizer block cascades 7 bands of equalizer to each channel to tailor the frequency characteristics of embedded speaker system according to user preferences and to emulate environment sound. The 7 bands equalizer includes two high pass filters, three band pass filters, one low pass filter and one biquad filter. One high pass filter cascaded in the front end is used to drop low frequency tone, The tone has a large amplitude and may damage a mini speaker. The high pass filter can be used to adjust Treble strength with gain control. One low pass filter with gain control can adjust the Bass strength. Three bands of band pass filters are used to emulate environment sounds, e.g., 'Pub', 'Live', 'Rock',... etc.. The gain, center frequency and bandwidth of each filter are all programmable. One biquad filter can switch to high-pass, low-pass or band-pass filter by register settings.

8.14. Wind Noise Reduction Filter

The wind filter is implemented by a high pass filter equalizer. The wind filter is mainly for ADC recording used. The cut-off frequency of wind filter is programmable and is varied according to different sample rate. The filter is used to remove DC offset at normal condition, and to remove wind noise at application mode.

There are two wind filters for two ADC filters:

Stereo 1 ADC Wind Filter => MX-D3 & MX-D4

Mono ADC Wind Filter => MX-EC & MX-ED

Wind filter setting procedure (For Stereo 1 ADC Filter):

Step1: Disable wind filter – MX-D3[15]

Step2: Select filter coarse coefficient – MX-D3[14:12] and MX-D3[10:8]

Step3: Select filter fine coefficient – MX-D4[13:8] and MX-D4[5:0]

Step4: Enable wind filter – MX-D3[15]

The following table (Table 13.) is shown the Fc with sample rate selection.
For the formula of Fc calculation is also shown as:

$$F_c = (F_s * \tan^{-1}(a/(2-a))) / \pi$$

Where:

Sample rate = 8K/12K/16K (MX-D3[14:12] and [10:8]), $a = 2^{-6} + n * 2^{-6}$ (n is MX-D4[13:8] & MX-D4[5:0])

Sample rate = 24K/32K (MX-D3[14:12] and [10:8]), $a = 2^{-7} + n * 2^{-7}$ (n is MX-D4[13:8] & MX-D4[5:0])

Sample rate = 44.1K/48L (MX-D3[14:12] and [10:8]), $a = 2^{-8} + n * 2^{-8}$ (n is MX-D4[13:8] & MX-D4[5:0])

Sample rate = 88.2K/96L (MX-D3[14:12] and [10:8]), $a = 2^{-9} + n * 2^{-9}$ (n is MX-D4[13:8] & MX-D4[5:0])

Sample rate = 176.4K/192L (MX-D3[14:12] and [10:8]), $a = 2^{-10} + n * 2^{-10}$ (n is MX-D4[13:8] & MX-D4[5:0])

Table 13. Sample Rate with filter coefficient for Wind Filter

PR-6E[11:6] n	L & R Channel Sample Rate Setting				
	8K	16K	32K	44.1K	48K
000000'b, 0	20.0	40.1	39.9	27.4	29.8
000001'b, 1	40.4	80.8	80.2	55.0	59.9
000010'b, 2	61.1	122.2	120.7	82.7	90.0
000011'b, 3	82.1	164.2	161.6	110.5	120.3
000100'b, 4	103.4	206.9	202.8	138.4	150.6
000101'b, 5	125.1	250.2	244.4	166.4	181.1
000110'b, 6	147.1	294.3	286.2	194.5	211.7
000111'b, 7	169.5	339.0	328.4	222.7	242.5
001000'b, 8	192.2	384.4	371.0	251.1	273.3
001001'b, 9	215.2	430.5	413.8	279.5	304.3
001010'b, 10	238.7	477.4	457.0	308.1	335.4
001011'b, 11	262.4	524.9	500.5	336.8	366.6
001100'b, 12	286.6	573.2	544.4	365.6	397.9
001101'b, 13	311.1	622.3	588.6	394.5	429.4
001110'b, 14	336.0	672.1	633.2	423.5	460.9
001111'b, 15	361.3	722.6	678.1	452.6	492.6
010000'b, 16	386.9	773.9	723.3	481.9	524.5
010001'b, 17	413.0	826.0	768.9	511.2	556.4
010010'b, 18	439.4	878.9	814.9	540.7	588.5
010011'b, 19	466.2	932.5	861.2	570.3	620.7
010100'b, 20	493.5	987.0	907.8	600.0	653.0
010101'b, 21	521.1	1042.2	954.9	629.8	685.5
010110'b, 22	549.1	1098.2	1002.2	659.7	718.1
010111'b, 23	577.5	1155.0	1050.0	689.8	750.8
011000'b, 24	606.3	1212.7	1098.1	719.9	783.6
011001'b, 25	635.5	1271.1	1146.6	750.2	816.6
011010'b, 26	665.1	1330.3	1195.5	780.6	849.6
011011'b, 27	695.2	1390.4	1244.7	811.1	882.9

PR-6E[11:6] n	L & R Channel Sample Rate Setting				
	8K	16K	32K	44.1K	48K
011100'b, 28	725.6	1451.2	1294.3	841.8	916.2
011101'b, 29	756.4	1512.9	1344.3	872.5	949.7
011110'b, 30	787.6	1575.3	1394.7	903.4	983.3
011111'b, 31	819.3	1638.6	1445.4	934.4	1017.0
100000'b, 32	851.3	1702.7	1496.5	965.5	1050.9
100001'b, 33	883.7	1767.5	1548.0	996.8	1084.9
100010'b, 34	916.6	1822.3	1599.9	1028.1	1119.0
100011'b, 35	949.8	1899.6	1652.2	1059.6	1153.3
100100'b, 36	983.3	1966.7	1704.9	1091.2	1187.7
100101'b, 37	1017.3	2034.7	1757.9	1122.9	1222.2
100110'b, 38	1051.6	2103.3	1811.4	1154.8	1256.9
100111'b, 39	1086.3	2172.7	1865.2	1186.7	1291.7
101000'b, 40	1121.4	2242.9	1919.5	1218.8	1326.6
101001'b, 41	1156.8	2313.7	1974.1	1251.0	1361.7
101010'b, 42	1192.6	2385.2	2029.1	1283.4	1396.9
101011'b, 43	1228.7	2457.4	2084.6	1315.8	1432.2
101100'b, 44	1265.1	2530.2	2140.4	1348.4	1467.7
101101'b, 45	1301.8	2603.6	2196.6	1381.1	1503.3
101110'b, 46	1338.8	2677.7	2253.3	1414.0	1539.0
101111'b, 47	1376.1	2752.3	2310.3	1447.0	1574.9
110000'b, 48	1413.7	2827.5	2367.7	1480.0	1610.9
110001'b, 49	1451.5	2903.1	2425.5	1513.3	1647.1
110010'b, 50	1489.6	2979.3	2483.8	1546.6	1683.4
110011'b, 51	1528.0	3056.0	2542.4	1580.1	1719.8
110100'b, 52	1566.5	3133.1	2601.5	1613.7	1756.4
110101'b, 53	1605.3	3210.6	2660.9	1647.4	1793.1
110110'b, 54	1644.2	3288.4	2720.8	1681.3	1830.0
110111'b, 55	1683.3	3366.6	2781.0	1715.3	1867.0
111000'b, 56	1722.5	3445.1	2841.7	1749.4	1904.1
111001'b, 57	1761.9	3523.9	2902.7	1783.6	1941.4
111010'b, 58	1801.4	3602.9	2964.2	1818.0	1978.8
111011'b, 59	1841.0	3682.1	3026.1	1852.5	2016.3
111100'b, 60	1880.7	3761.4	3088.3	1887.1	2054.0
111101'b, 61	1920.4	3840.8	3151.0	1921.9	2091.9
111110'b, 62	1960.2	3920.4	3214.1	1956.8	2129.9
111111'b, 63	2000.0	4000.0	3277.5	1991.8	2168.0

8.15. I²C Control Interface

I²C is a 2-wire (SCL/SDA) half-duplex serial communication interface, supporting only slave mode. SCL is used for clock and SDA is for data. SCL clock supports up to 400KHz rate and SDA data is an open drain structure. The input has built-in spike filter and can remove less than 50ns spike at SCL and SDA.

8.15.1. Address Setting

Table 14. Address Setting (0x34h)

(MSB)	BIT						(LSB)
0	0	1	1	0	1	0	R/W

8.15.2. Complete Data Transfer

Data Transfer over I²C Control Interface

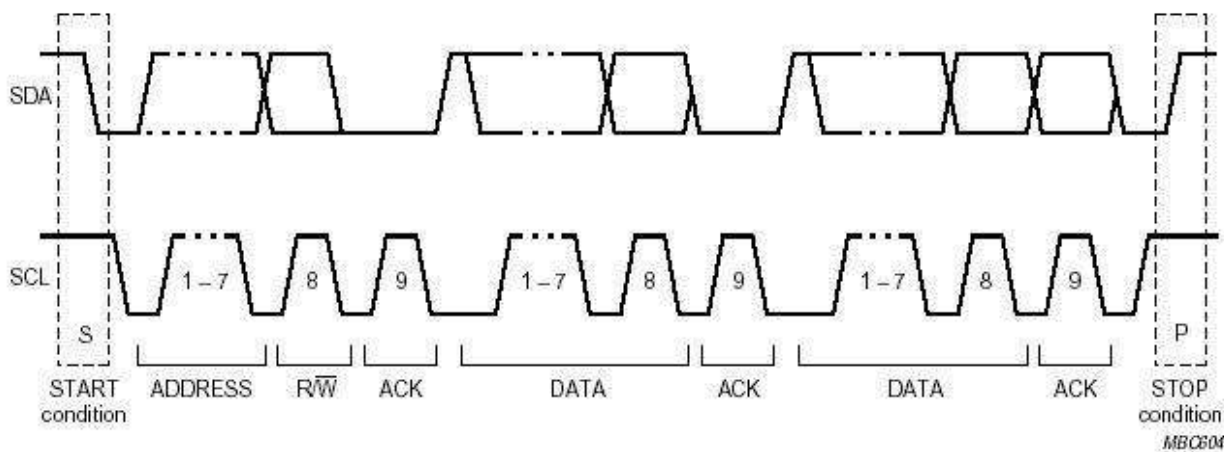
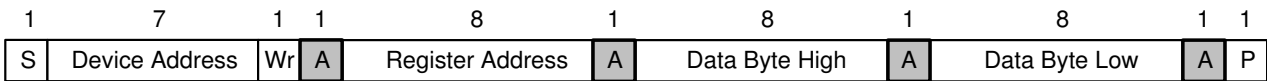
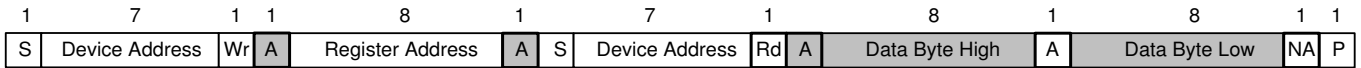


Figure 28. Data Transfer Over I²C Control Interface

Write WORD Protocol
Table 15. Write WORD Protocol

Read WORD Protocol
Table 16. Read WORD Protocol


- | | |
|---|--|
| <p>S: Start Condition</p> <p>Slave Address: 7-bit Device Address</p> <p>Wr: 0 for Write Command</p> <p>Rd: 1 for Read Command</p> <p>Command Code: 8-bit Register Address</p> | <p>A: 0 for ACK, 1 for NACK</p> <p>Data Byte: 16-bit Mixer data</p> <p><input type="checkbox"/>: Master-to-Slave</p> <p><input checked="" type="checkbox"/>: Slave-to-Master</p> |
|---|--|

8.16. GPIO, Interrupt and Jack Detection

The ALC5645 supports six GPIOs – GPIO1/GPIO2/GPIO3/GPIO4/GPIO5/GPIO6. For GPIO function, the GPIO can be configured to input or output. For input type, the internal circuit can read pin status and report to register table. For output type, the internal circuit can drive this pin to high or low to control external device. In GPIO function, the pin polarity can be controlled by register at output type.

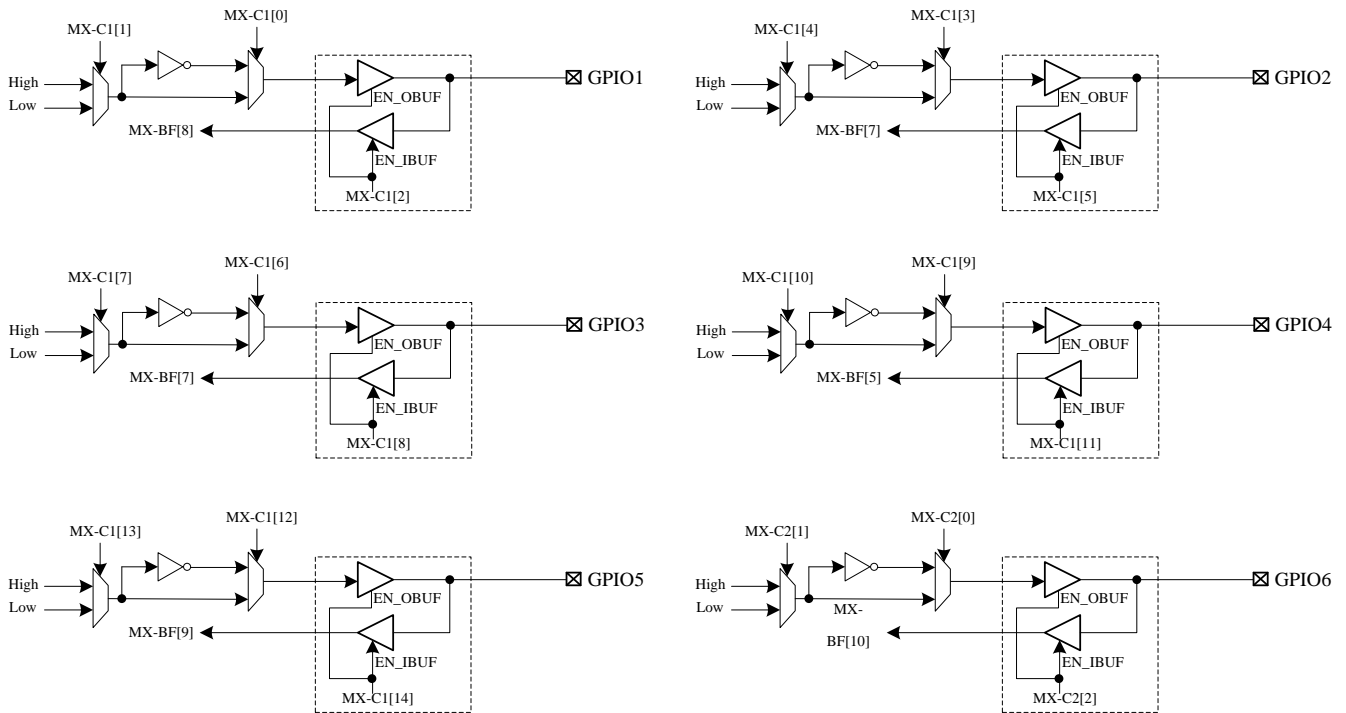
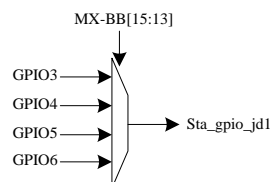


Figure 29. GPIO Function Block

For the jack detection function, there are four GPIOs (GPIO3/4/5/6) can be configured as jack detection pins and also have JD1 and JD2 can as jack detection pin. For GPIO jack detection pin source selection is controlled by MX-BB[15:13]. It's JD status is sta_gpio_jd1 – MX-BF[4]. For JD1, it can detect two ports. Which JD statuses are sta_jd1_1 – MX-BF[12] & sta_jd1_2 – MX-BF[13]. For JD2, it can detect one port. Which JD status is sta_jd2 – MX-BF[14].



For IRQ function as shown at Figure 24, the IRQ output source can be selected from JD1 Status, JD2 Status, GPIO JD Status, InLine Command Status and MICBIAS1/2 Over-Current Status. When either status is triggered, the GPIO will output a flag as interrupt signal.

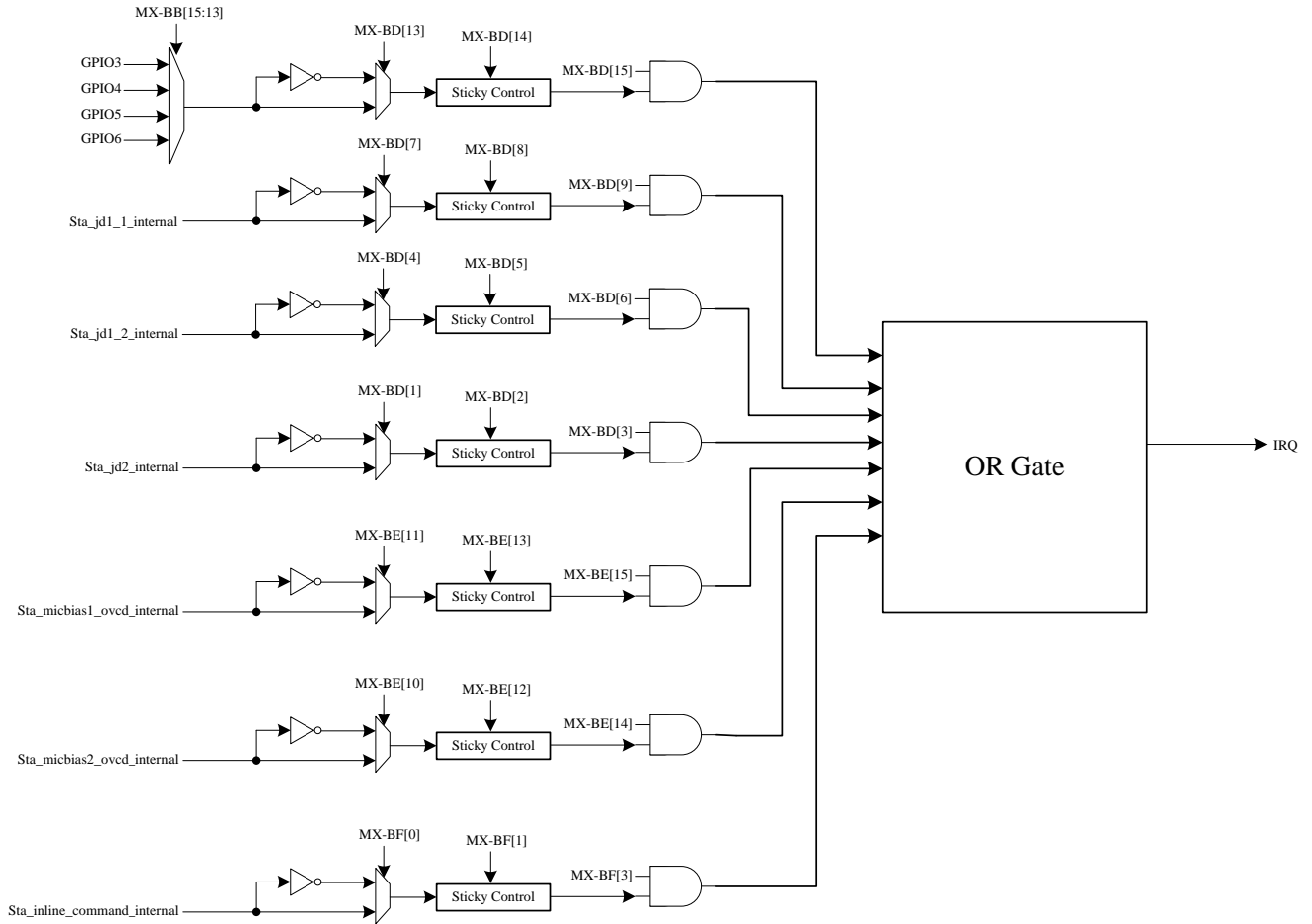
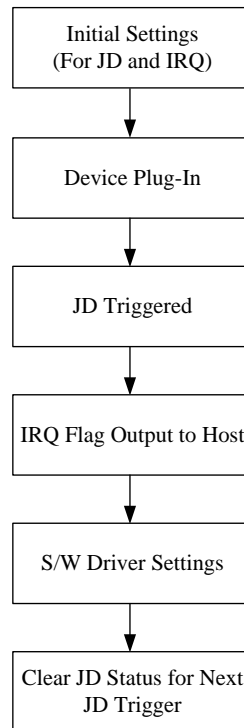


Figure 30. IRQ Function Block

In general, the IRQ output needs to combine with JD function. When JD is trigger, IRQ will output a flag to host to notice S/W driver. The S/W driver will do some settings by system design. The behavior flow chard as following:



The MICBIAS supports short current detection function. When MICBIAS circuit detects over-current happen, MICBIAS circuit will generate an over-current flag. The flag can generate an interrupt signal to notice host and let S/W do follow-up processes.

The jack detect function can be used to turn-on or turn-off the related output ports. When jack detect pin is trigged, the selected output ports will be turn-on or turn-off. For example on HP and SPK auto switch when JD is trigger.

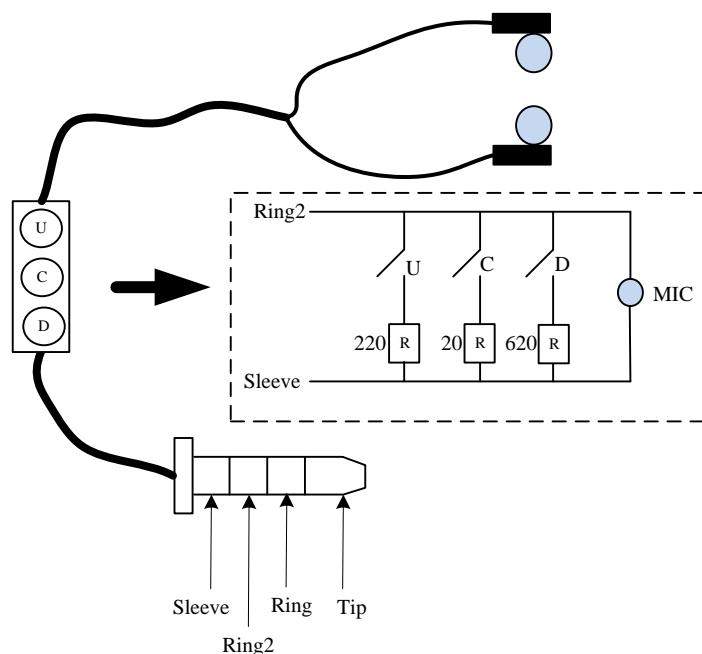
Setting procedure:

1. Select JD status source: use sta_jd1_1 as JD source. $MX-F8[2:0] = 001'b$ & $MX-F9[14:12] = 001'b$
2. Set JD status polarity for HP and SPK
 $MX-BB[11:10] = 10'b$, JD status low to trigger HPO
 $MX-BB[9:6] = 1111'b$, JD status high to trigger SPK
3. When JD status is low, HP_OUT is un-mute and SPK is mute.
 When JD status is low go high, HP is mute and SPK is un-mute.

Note: For HP and SPK port switch function, driver need to turn-on DAC to HP path and DAC to SPK path first.

8.17. Push Button Detection

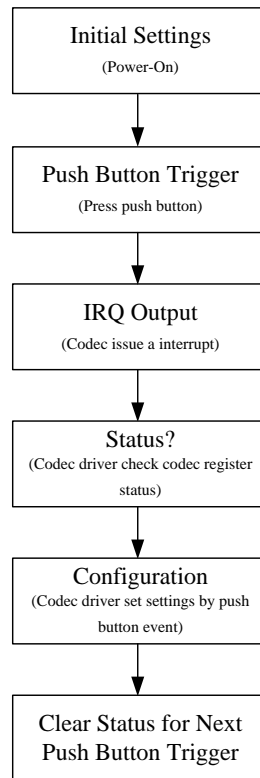
The ALC5645 has built-in push button detection circuit inside. It can supports up to three push buttons. Each button has three status can be shown on register (MX-DBh) – one click, double click and hold. The push button event will also cause an interrupt to IRQ output to notice external host.



Push Button Resistance	Resistance Range	Recommend Value
Up button, R2	150 ~ 280 Ohm	220 Ohm
Center button, R1	0 ~ 50 Ohm	20 Ohm
Down button, R3	550 ~ 650 Ohm	620 Ohm

Push Button Detection Status:

Button #	Button Behavior	Register Status
Up button	One click	MX-DBh[15]
	Double click	MX-DBh[14]
	Hold	MX-DBh[13]
Center button	One click	MX-DBh[12]
	Double click	MX-DBh[11]
	Hold	MX-DBh[10]
Down button	One click	MX-DBh[9]
	Double click	MX-DBh[8]
	Hold	MX-DBh[7]

Push Button Detection Flow Chart:

8.18. Power Management

ALC5645 detailed Power Management control registers are supported in MX-61h, 62h, 63h, 64h, 65h and 66h. Each particular block will only be active when each bit MX-61h, 62h, 63h, 64h, 65h and 66h is set to enable.

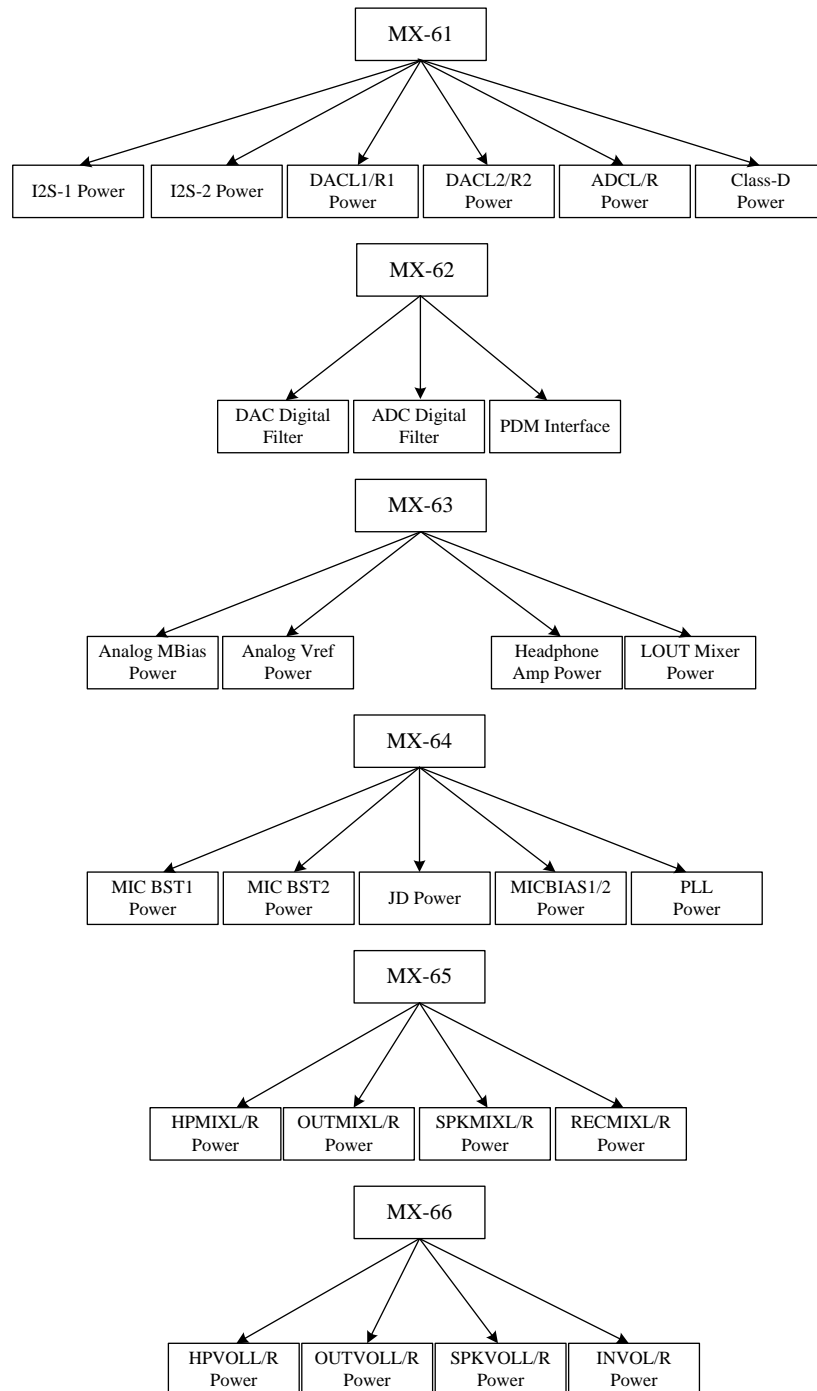
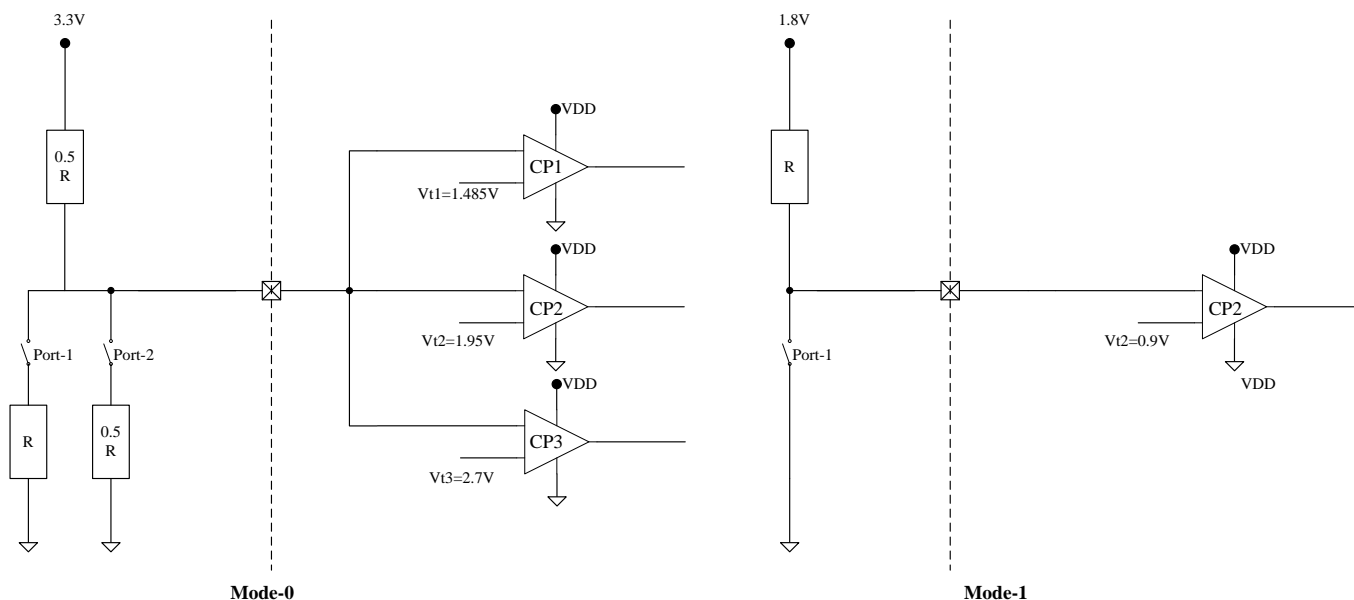


Figure 31. Power Management

8.19. Multi-Jack Jack Detection Pin (JD1)

The JD1 pin supports up to two ports jack detection. When supports two ports jack detection, the external pull-high voltage is 3.3V. When supports one ports jack detection, the external pull-high voltage is 1.8V. The application schematic as shows below:



MX-94h: JD1 Control

Name	Bits	Read/Write	Reset State	Description
reserved	15:2	R/W	0'h	Reserved
Sel_mode_jd1	1:0	R/W	0'h	JD1 Mode Control 00'b: Mode-0, two port jack detection 01'b: Mode-1, one port jack detection Others: Reserved

MX-BFh: JD1 Status

Name	Bits	Read/Write	Reset State	Description
sta_jd1_2 (Port-2)	13	R	0'h	Status of JD1_2 Jack detection . Read: Return status of Jack Detect Select output Write: Write '0' to clear stick bit
sta_jd1_1 (Port-1)	12	R	0'h	Status of JD1_1 Jack detection . Read: Return status of Jack Detect Select output Write: Write '0' to clear stick bit

9. Registers List

ALC5645 register map as shown as following and accessing unimplemented registers, will return a 0.

9.1. Register Map

Table 17. Register Map

Type	Name	Description	Register Address	Reset State
Reset	S/W Reset	S/W Reset & Device ID	MX-00h	0x0000'h
	SPKOUT	Speaker Output Volume & Mute/Un-Mute	MX-01h	0xC8C8'h
	HPOUT	Headphone Output Volume & Mute/Un-Mute	MX-02h	0xC8C8'h
	LOUT	Line Output Volume & Mute/Un-Mute	MX-03h	0xC8C8'h
		Line Output Control	MX-05h	0x0000'h
	IN1	IN1 Control 1	MX-0Ah	0x0002'h
	IN1	IN1 Control 2	MX-0Bh	0x0827'h
	IN1	IN1 Control 3	MX-0Ch	0x0000'h
	IN2	IN2 Mode and Gain Boost Control	MX-0Eh	0x0000'h
	INL/INR	INL/INR Volume Control	MX-0Fh	0x0808'h
Digital Gain/Volume	DACL1/R1	DACL1/R1 Digital Volume Control	MX-19h	0xAFAF'h
	DACL2/R2-1	DACL2/R2 Digital Volume Control	MX-1Ah	0xAFAF'h
	DACL2/R2-2	DACL2/R2 Digital Mute/Un-Mute Control	MX-1Bh	0x0000'h
	ADC	Stereo1 ADCL/R Digital Volume & Mute/Un-Mute Control	MX-1Ch	0x2F2F'h
	ADC	Mono ADCL/R Digital Path Volume Control	MX-1Dh	0x2F2F'h
	ADC	Stereo1 ADC Filter Boost Gain for DMIC	MX-1Eh	0x0000'h
	ADC	Mono ADC Filter Boost Gain for DMIC	MX-20h	0x0000'h
Digital Mixer	ADC	Stereo1 ADC Digital Mixer Control	MX-27h	0x7860'h
	ADC	Mono ADC Digital Mixer Control	MX-28h	0x7871'h
	ADC	ADC to DAC Digital Mixer Control	MX-29h	0x8080'h
	DAC	DAC Stereo Digital Mixer Control	MX-2Ah	0x5656'h
	DAC	DAC Mono Digital Mixer Control	MX-2Bh	0x5454'h
	DAC	DAC Stereo/Mono to DD Mixer Control	MX-2Ch	0xAAA0'h
	Copy Mode	ADC/DAC Data Copy Mode Control	MX-2Fh	0x1002'h
PDM Interface	PDM	PDM Interface Control	MX-31h	0x5000'h
Input Mixer	RECMIXL-1	RECMIXL Gain Control	MX-3Bh	0x0000'h
	RECMIXL-2	RECMIXL Gain & Selection Control	MX-3Ch	0x007F'h
	RECMIXR-1	RECMIXR Gain Control	MX-3Dh	0x0000'h
	RECMIXR-2	RECMIXR Gain & Selection Control	MX-3Eh	0x007F'h
Output Mixer	HPMIX	HPMIXL Gain & Selection Control	MX-3Fh	0x0000'h
	HPMIX	HPMIXL Gain & Selection Control	MX-40h	0x001F'h
	HPMIX	HPMIXR Gain & Selection Control	MX-41h	0x0000'h
	HPMIX	HPMIXR Gain & Selection Control	MX-42h	0x001F'h
	HPOMIX	HPOMIX Gain & Selection Control	MX-45h	0x6000'h
	SPKMIX	SPKMIXL Gain & Selection Control	MX-46h	0x003E'h
	SPKMIX	SPKMIXR Gain & Selection Control	MX-47h	0x003E'h
	SPOMIX	SPOMIX Gain & Selection Control	MX-48h	0xF807'h
	SPK Amp	SPK Amp Gain Control	MX-4Ah	0x0004'h
	OUTMIXL	OUTMIXL Gain & Selection Control	MX-4Dh	0x0000'h
	OUTMIXL	OUTMIXL Gain & Selection Control	MX-4Eh	0x0000'h
	OUTMIXL	OUTMIXL Gain & Selection Control	MX-4Fh	0x001F'h

Type	Name	Description	Register Address	Reset State
	OUTMIXR	OUTMIXR Gain & Selection Control	MX-50h	0x0000'h
	OUTMIXR	OUTMIXR Gain & Selection Control	MX-51h	0x0000'h
	OUTMIXR	OUTMIXR Gain & Selection Control	MX-52h	0x001F'h
	LOUTMIX	LOUTMIX Gain & Selection Control	MX-53h	0xF000'h
Haptic Generator		Gaptic Generator Control	MX-56h	0x0111'h
		Gaptic Generator Control	MX-57h	0x0064'h
		Gaptic Generator Control	MX-58h	0xEF0E'h
		Gaptic Generator Control	MX-59h	0xF0F0'h
		Gaptic Generator Control	MX-5Ah	0xEF0E'h
		Gaptic Generator Control	MX-5Bh	0xF0F0'h
		Gaptic Generator Control	MX-5Ch	0xEF0E'h
		Gaptic Generator Control	MX-5Dh	0xF0F0'h
Power Management	Management-1	I2S & DAC & ADC & Class-D Power Control	MX-61h	0x0300'h
	Management-2	Digital Filter & PDM Power Control	MX-62h	0x0000'h
	Management-3	VREF & MBias & LOUTMIX & HP Power Control	MX-63h	0x00C0'h
	Management-4	MICBST & MICBIAS & PLL & JD Power Control	MX-64h	0x0000'h
	Management-5	SPKMIX & OUTMIX & RECMIX Power Control	MX-65h	0x0000'h
	Management-6	MICBIAS & OUTVOL & HPOVOL & INVOL Power Control	MX-66h	0x0000'h
PR Register	PR Index	PR Register Index	MX-6Ah	0x0000'h
	PR Data	PR Register Data	MX-6Ch	0x0000'h
Digital Interface	I2S1 Port Ctrl	I2S-1 Interface Control	MX-70h	0x8000'h
	I2S2 Port Ctrl	I2S-2 Interface Control	MX-71h	0x8000'h
	ADC/DAC Clock	ADC/DAC Clock Control	MX-73h	0x1114'h
	ADC/DAC HPF	ADC/DAC HPF Control	MX-74h	0x3E00'h
Digital MIC		Digital Microphone Control	MX-75h	0x1405'h
		Digital Microphone Control	MX-76h	0x0005'h
TDM		TDM Interface Control	MX-77h	0x0C00'h
		TDM Interface Control	MX-78h	0x0000'h
		TDM Interface Control	MX-79h	0x0123'h
Global Clock	Clock	Global Clock Control	MX-80h	0x0000'h
	PLL	PLL Control 1	MX-81h	0x0000'h
	PLL	PLL Control 2	MX-82h	0x0000'h
	ASRC	ASRC Control 1	MX-83h	0x0000'h
	ASRC	ASRC Control 2	MX-84h	0x0000'h
	ASRC	ASRC Control 3	MX-85h	0x0000'h
	ASRC	ASRC Control 4	MX-8Ah	0x0000'h
HP Amp	HP	HP Output De-Pop Control 1	MX-8Eh	0x0004'h
		HP Output De-Pop Control 2	MX-8Fh	0x1100'h
		HP Amp Control	MX-D6h	0x0400'h
		HP Amp Control	PR-90h	0x3300'h
		HP Amp Control	PR-91h	0x2200'h

Type	Name	Description	Register Address	Reset State
MICBIAS	MICBIAS	MICBIAS Control	MX-93h	0x0000'h
JD1		JD1 Control	MX-94h	0x0000'h
SPK AMP		Class-D Amp Control	MX-A0h	0xA0A8'h
EQ	ADC EQ	ADC EQ Control 1	MX-AE	0x6000'h
	ADC EQ	ADC EQ Control 2	MX-AF	0x0000'h
	DAC EQ	DAC EQ Control 1	MX-B0h	0x6000'h
	DAC EQ	DAC EQ Control 2	MX-B1h	0x0000'h
	EQ-Parameter	DAC_L EQ (LPF: a1)	PR-A4h	0x1C10'h
	EQ-Parameter	DAC_L EQ (LPF: H0)	PR-A5h	0x01F4'h
	EQ-Parameter	DAC_R EQ (LPF: a1)	PR-A6h	0x1C10'h
	EQ-Parameter	DAC_R EQ (LPF: H0)	PR-A7h	0x01F4'h
	EQ-Parameter	DAC_L EQ (BPF2: a1)	PR-AEh	0xC882'h
	EQ-Parameter	DAC_L EQ (BPF2: a2)	PR-AFh	0x1C10'h
	EQ-Parameter	DAC_L EQ (BPF2: H0)	PR-B0h	0x01F4'h
	EQ-Parameter	DAC_R EQ (BPF2: a1)	PR-B1h	0xC882'h
	EQ-Parameter	DAC_R EQ (BPF2: a2)	PR-B2h	0x1C10'h
	EQ-Parameter	DAC_R EQ (BPF2: H0)	PR-B3h	0x01F4'h
	EQ-Parameter	DAC_L EQ (BPF3: a1)	PR-B4h	0xE904'h
	EQ-Parameter	DAC_L EQ (BPF3: a2)	PR-B5h	0x1C10'h
	EQ-Parameter	DAC_L EQ (BPF3: H0)	PR-B6h	0x01F4'h
	EQ-Parameter	DAC_R EQ (BPF3: a1)	PR-B7h	0xE904'h
	EQ-Parameter	DAC_R EQ (BPF3: a2)	PR-B8h	0x1C10'h
	EQ-Parameter	DAC_R EQ (BPF3: H0)	PR-B9h	0x01F4'h
	EQ-Parameter	DAC_L EQ (BPF4: a1)	PR-BAh	0xE904'h
	EQ-Parameter	DAC_L EQ (BPF4: a2)	PR-BBh	0x1C10'h
	EQ-Parameter	DAC_L EQ (BPF4: H0)	PR-BCh	0x01F4'h
	EQ-Parameter	DAC_R EQ (BPF4: a1)	PR-BDh	0xE904'h
	EQ-Parameter	DAC_R EQ (BPF4: a2)	PR-BEh	0x1C10'h
	EQ-Parameter	DAC_R EQ (BPF4: H0)	PR-BFh	0x01F4'h
	EQ-Parameter	DAC_L EQ (HPF1: a1)	PR-C0h	0x1C10'h
	EQ-Parameter	DAC_L EQ (HPF1: H0)	PR-C1h	0x01F4'h
	EQ-Parameter	DAC_R EQ (HPF1: a1)	PR-C2h	0x1C10'h
	EQ-Parameter	DAC_R EQ (HPF1: H0)	PR-C3h	0x01F4'h
	EQ-Parameter	DAC_L EQ (HPF2: a1)	PR-C4h	0x2000'h
	EQ-Parameter	DAC_L EQ (HPF2: a2)	PR-C5h	0x0000'h
	EQ-Parameter	DAC_L EQ (HPF2: H0)	PR-C6h	0x1FF1'h
	EQ-Parameter	DAC_R EQ (HPF2: a1)	PR-C7h	0x2000'h
	EQ-Parameter	DAC_R EQ (HPF2: a2)	PR-C8h	0x0000'h
	EQ-Parameter	DAC_R EQ (HPF2: H0)	PR-C9h	0x1FF1'h
	EQ-Parameter	DAC_L EQ Pre-Volume Control	PR-CAh	0x0800'h
	EQ-Parameter	DAC_R EQ Pre-Volume Control	PR-CBh	0x0800'h
	EQ-Parameter	DAC_L EQ Post-Volume Control	PR-CCh	0x0800'h
	EQ-Parameter	DAC_R EQ Post-Volume Control	PR-CDh	0x0800'h
	EQ-Parameter	ADC EQ (LPF: a1)	PR-CEh	0x1C10'h
	EQ-Parameter	ADC EQ (LPF: H0)	PR-CFh	0x01F4'h
	EQ-Parameter	ADC EQ (BPF1: a1)	PR-D0h	0xE904'h
	EQ-Parameter	ADC EQ (BPF1: a2)	PR-D1h	0x1C10'h
	EQ-Parameter	ADC EQ (BPF1: H0)	PR-D2h	0x01F4'h
	EQ-Parameter	ADC EQ (BPF2: a1)	PR-D3h	0xE904'h
	EQ-Parameter	ADC EQ (BPF2: a2)	PR-D4h	0x1C10'h
	EQ-Parameter	ADC EQ (BPF2: H0)	PR-D5h	0x01F4'h

Type	Name	Description	Register Address	Reset State
	EQ-Parameter	ADC EQ (BPF3: a1)	PR-D6h	0xE904'h
	EQ-Parameter	ADC EQ (BPF3: a2)	PR-D7h	0x1C10'h
	EQ-Parameter	ADC EQ (BPF3: H0)	PR-D8h	0x01F4'h
	EQ-Parameter	ADC EQ (BPF4: a1)	PR-D9h	0xE904'h
	EQ-Parameter	ADC EQ (BPF4: a2)	PR-DAh	0x1C10'h
	EQ-Parameter	ADC EQ (BPF4: H0)	PR-DBh	0x01F4'h
	EQ-Parameter	ADC EQ (HPF1: a1)	PR-DC h	0x1C10'h
	EQ-Parameter	ADC EQ (HPF1: H0)	PR-DDh	0x01F4'h
	EQ-Parameter	ADC EQ Pre-Volume Control	PR-E1h	0x0800'h
	EQ-Parameter	ADC EQ Post-Volume Control	PR-E2h	0x0800'h
	EQ-Parameter	DAC_L Biquad EQ (BPF1: h0-1)	PR-E5h	0x0000'h
	EQ-Parameter	DAC_L Biquad EQ (BPF1: h0-2)	PR-E6h	0x0000'h
	EQ-Parameter	DAC_L Biquad EQ (BPF1: b1-1)	PR-E7h	0x0000'h
	EQ-Parameter	DAC_L Biquad EQ (BPF1: b1-2)	PR-E8h	0x0000'h
	EQ-Parameter	DAC_L Biquad EQ (BPF1: b2-1)	PR-E9h	0x0000'h
	EQ-Parameter	DAC_L Biquad EQ (BPF1: b2-2)	PR-EAh	0x0000'h
	EQ-Parameter	DAC_L Biquad EQ (BPF1: a1-1)	PR-EBh	0x0000'h
	EQ-Parameter	DAC_L Biquad EQ (BPF1: a1-2)	PR-ECh	0x0000'h
	EQ-Parameter	DAC_L Biquad EQ (BPF1: a2-1)	PR-EDh	0x0000'h
	EQ-Parameter	DAC_L Biquad EQ (BPF1: a2-2)	PR-EEh	0x0000'h
	EQ-Parameter	DAC_R Biquad EQ (BPF1: h0-1)	PR-EFh	0x0000'h
	EQ-Parameter	DAC_R Biquad EQ (BPF1: h0-2)	PR-F0h	0x0000'h
	EQ-Parameter	DAC_R Biquad EQ (BPF1: b1-1)	PR-F1h	0x0000'h
	EQ-Parameter	DAC_R Biquad EQ (BPF1: b1-2)	PR-F2h	0x0000'h
	EQ-Parameter	DAC_R Biquad EQ (BPF1: b2-1)	PR-F3h	0x0000'h
	EQ-Parameter	DAC_R Biquad EQ (BPF1: b2-2)	PR-F4h	0x0000'h
	EQ-Parameter	DAC_R Biquad EQ (BPF1: a1-1)	PR-F5h	0x0000'h
	EQ-Parameter	DAC_R Biquad EQ (BPF1: a1-2)	PR-F6h	0x0000'h
	EQ-Parameter	DAC_R Biquad EQ (BPF1: a2-1)	PR-F7h	0x0000'h
	EQ-Parameter	DAC_R Biquad EQ (BPF1: a2-2)	PR-F8h	0x0000'h
DRC/AGC	DRC/AGC	DRC/AGC Control 2	MX-B3h	0x001F'h
	DRC/AGC	DRC/AGC Control 3	MX-B4h	0x0206'h
	DRC/AGC	DRC/AGC Control 4	MX-B5h	0x1F00'h
	DRC/AGC	DRC/AGC Control 5	MX-B6h	0x0000'h
	DRC/AGC	DRC/AGC Control 6	MX-B7h	0x4000'h
	DRC/AGC	DRC/AGC Limiter Control	MX-E7h	0x0200'h
	DRC/AGC	DRC/AGC Bass Limiter Control	MX-E9h	0x0200'h
	DRC/AGC	DRC/AGC Bass Control	MX-EAh	0x0F20'h
	DRC/AGC	DRC/AGC Bass Control	MX-F0h	0x001F'h
	DRC/AGC	DRC/AGC Bass Control	MX-F1h	0x0206'h
	DRC/AGC	DRC/AGC Bass Control	MX-F2h	0x1F00'h
	DRC/AGC	DRC/AGC Bass Control	MX-F3h	0x0000'h
	DRC/AGC	DRC/AGC Bass Control	MX-F4h	0x4000'h
Jack Detection	JD	Jack Detection Control	MX-BBh	0x0000'h
	JD	Jack Detection Control	MX-BCh	0x0000'h
	JD	Jack Detection Control	MX-F8h	0x0000'h
	JD	Jack Detection Control	MX-F9h	0x0000'h
IRQ	IRQ	IRQ Control 1	MX-BDh	0x0000'h
	IRQ	IRQ Control 2	MX-BEh	0x0000'h
	IRQ	IRQ Control 3	MX-BFh	0x0000'h
GPIO	GPIO	GPIO Control 1	MX-C0h	0x0000'h

Type	Name	Description	Register Address	Reset State
	GPIO	GPIO Control 2	MX-C1h	0x0000'h
	GPIO	GPIO Control 3	MX-C2h	0x0000'h
SounzReal™ Post-Processing	BassBack	BassBack Control	MX-CFh	0x0013'h
	TruTreble	TruTreble Control 1	MX-D0h	0x0680'h
	TruTreble	TruTreble Control 2	MX-D1h	0x1C17'h
Wind Filter	Stereo1	Stereo1 ADC Wind Filter Control 1	MX-D3h	0xAA20'h
	Stereo1	Stereo1 ADC Wind Filter Control 2	MX-D4h	0x0000'h
	Mono	Mono ADC Wind Filter Control 1	MX-ECh	0xAA20'h
	Mono	Mono ADC Wind Filter Control 2	MX-EDh	0x0000'h
SVOL & ZCD	SVOL & ZCD	Soft Volume and ZCD Control 1	MX-D9h	0x0809'h
		Soft Volume and ZCD Control 2	MX-DAh	0x0000'h
InLine Command		Inline Command Control 1	MX-DBh	0x0001'h
		Inline Command Control 2	MX-DCh	0x0049'h
		Inline Command Control 3	MX-DDh	0x0003'h
General Control		General Control 1	MX-FAh	0x0090'h
		ADC/DAC RESET Control	PR-3D	0x2808'h
Vendor ID	ID	Vendor ID	MX-FEh	0x10EC'h

9.2. MX-00h: S/W Reset & Device ID

Default: 0000'h

Table 18. MX-00h: S/W Reset


Port Name	Bits	Read/Write	Reset State	Description
Reserved	15:2	R	0'h	Reserved
Device_id	1	R	0'h	ALC5645
Reserved	0	R	0'h	Reserved

Note: Writes to this register will reset all registers to their default values.

9.3. MX-01h: Speaker Output Control

Default: C8C8'h

Table 19. MX-01h: Speaker Output Control

Port Name	Bits	Read/Write	Reset State	Description
mu_spo_l	15	R/W	1'h	Mute Control for Left Speaker Output Port (SPOLP/LN) 0'b: Un-Mute 1'b: Mute
Mu_spkvoll_in	14	R/W	1'h	Mute Control for Left Speaker Volume Channel (SPKVOLL) 0'b: Un-Mute 1'b: Mute
vol_spol	13:8	R/W	8'h	Left Speaker Channel Volume Control (SPKVOLL)  00'h: +12dB ... 08'h: 0dB ... 27'h: -46.5dB, with 1.5dB/step
mu_spo_r	7	R/W	1'h	Mute Control for Right Speaker Output Port (SPORP/RN) 0'b: Un-Mute 1'b: Mute
Mu_spkvollr_in	6	R/W	1'h	Mute Control for Right Speaker Volume Channel (SPKVOLR) 0'b: Un-Mute 1'b: Mute

Port Name	Bits	Read/Write	Reset State	Description
Vol_spor	5:0	R/W	8'h	Right Speaker Channel Volume Control (SPKVOLR) ① 00'h: +12dB ... 08'h: 0dB ... 27'h: -46.5dB, with 1.5dB/step

① Volume Table

DEC	HEX	Boost Gain	DEC	HEX	Boost Gain	DEC	HEX	Boost Gain
0	0	12	16	10	-12	32	20	-36
1	1	10.5	17	11	-13.5	33	21	-37.5
2	2	9	18	12	-15	34	22	-39
3	3	7.5	19	13	-16.5	35	23	-40.5
4	4	6	20	14	-18	36	24	-42
5	5	4.5	21	15	-19.5	37	25	-43.5
6	6	3	22	16	-21	38	26	-45
7	7	1.5	23	17	-22.5	39	27	-46.5
8	8	0	24	18	-24			
9	9	-1.5	25	19	-25.5			
10	A	-3	26	1A	-27			
11	B	-4.5	27	1B	-28.5			
12	C	-6	28	1C	-30			
13	D	-7.5	29	1D	-31.5			
14	E	-9	30	1E	-33			
15	F	-10.5	31	1F	-34.5			

9.4. MX-02h: Headphone Output Control

Default: C8C8'h

Table 20. MX-02h: Headphone Output Control

Name	Bits	Read/Write	Reset State	Description
mu_hpo_1	15	R/W	1'h	Mute Control for Left Headphone Output Port (HPOL) 0'b: Un-Mute 1'b: Mute

Name	Bits	Read/Write	Reset State	Description
Mu_hpovoll_in	14	R/W	1'h	Mute Control for Left Headphone Volume Channel (HPOVOLL) 0'b: Un-Mute 1'b: Mute
vol_hpol	13:8	R/W	8'h	Left Headphone Channel Volume Control (HPOVOLL) ❶ 00'h: +12dB ... 08'h: 0dB ... 27'h: -46.5dB, with 1.5dB/step
mu_hpo_r	7	R/W	1'h	Mute Control Right Headphone Output Port (HPOR) 0'b: Un-Mute 1'b: Mute
Mu_hpovolr_in	6	R/W	1'h	Mute Control for Right Headphone Volume Channel (HPOVOLR) 0'b: Un-Mute 1'b: Mute
Vol_hpor	5:0	R/W	8'h	Right Headphone Channel Volume Control (HPOVOLR) ❶ 00'h: +12dB ... 08'h: 0dB ... 27'h: -46.5dB, with 1.5dB/step

❶ Volume Table

DEC	HEX	Boost Gain	DEC	HEX	Boost Gain	DEC	HEX	Boost Gain
0	0	12	16	10	-12	32	20	-36
1	1	10.5	17	11	-13.5	33	21	-37.5
2	2	9	18	12	-15	34	22	-39
3	3	7.5	19	13	-16.5	35	23	-40.5
4	4	6	20	14	-18	36	24	-42
5	5	4.5	21	15	-19.5	37	25	-43.5
6	6	3	22	16	-21	38	26	-45
7	7	1.5	23	17	-22.5	39	27	-46.5
8	8	0	24	18	-24			
9	9	-1.5	25	19	-25.5			
10	A	-3	26	1A	-27			

11	B	-4.5	27	1B	-28.5			
12	C	-6	28	1C	-30			
13	D	-7.5	29	1D	-31.5			
14	E	-9	30	1E	-33			
15	F	-10.5	31	1F	-34.5			

9.5. MX-03h: LINE Output Control

Default: C8C8'h

Table 21. MX-03h: LINE Output Control

Name	Bits	Read/Write	Reset State	Description
Mu_lout_l	15	R/W	1'h	Mute Control for Left Line Output Port(LOUTL) 0'b: Un-Mute 1'b: Mute
Mu_outvoll_in	14	R/W	1'h	Mute Control for Left Output Volume Channel (OUTVOLL) 0'b: Un-Mute 1'b: Mute
Vol_outl	13:8	R/W	08'h	Left Output Volume Control (OUTVOLL) ❶ 00'h: +12dB ... 08'h: 0dB ... 27'h: -46.5dB, with 1.5dB/step
Mu_lout_r	7	R/W	1'h	Mute Control for Right Line Output Port (LOUTR) 0'b: Un-Mute 1'b: Mute
Mu_outvolr_in	6	R/W	1'h	Mute Control for Right Output Volume Channel (OUTVOLR) 0'b: Un-Mute 1'b: Mute
Vol_outr	5:0	R/W	08'h	Right Output Volume Control ❶ 00'h: +12dB ... 08'h: 0dB ... 27'h: -46.5dB, with 1.5dB/step

❶ Volume Table

DEC	HEX	Boost Gain	DEC	HEX	Boost Gain	DEC	HEX	Boost Gain
0	0	12	16	10	-12	32	20	-36
1	1	10.5	17	11	-13.5	33	21	-37.5
2	2	9	18	12	-15	34	22	-39

3	3	7.5	19	13	-16.5	35	23	-40.5
4	4	6	20	14	-18	36	24	-42
5	5	4.5	21	15	-19.5	37	25	-43.5
6	6	3	22	16	-21	38	26	-45
7	7	1.5	23	17	-22.5	39	27	-46.5
8	8	0	24	18	-24			
9	9	-1.5	25	19	-25.5			
10	A	-3	26	1A	-27			
11	B	-4.5	27	1B	-28.5			
12	C	-6	28	1C	-30			
13	D	-7.5	29	1D	-31.5			
14	E	-9	30	1E	-33			
15	F	-10.5	31	1F	-34.5			

9.6. MX-05h: LINE Output Control

Default: 0000'h

Table 22. MX-05h: LINE Output Control

Name	Bits	Read/Write	Reset State	Description
Reserved	15:1	R	0'h	Reserved
En_dfo1	0	R/W	0'h	Line Output Differential Mode Control 0'b: Disable 1'b: Enable *If line output source from DAC : LOUTP=DACLP LOUTN=DACLN *If line output source from OUTMIX : LOUTP=OUTVOLLP LOUTN=OUTVOLRN

9.7. MX-0Ah: IN1 Port Control - 1

Default: 0002'h

Table 23. MX-0Dh: IN1 Input Control - 1

Name	Bits	Read/Write	Reset State	Description
Sel_bst1	15:12	R/W	0'h	IN1 Boost Control (BST1) 0000'b: Bypass 0001'b: +20dB 0010'b: +24dB 0011'b: +30dB 0100'b: +35dB 0101'b: +40dB 0110'b: +44dB 0111'b: +50dB 1000'b: +52dB Others : Reserved
reserved	11:3	R/W	0'h	Reserved
En_bst1	2	R/W	0'h	IN1 Port Enable Control 0'b: Disable 1'b: Enable
reserved	1:0	R/W	2'h	Reserved

9.8. MX-0Bh: IN1 Port Control - 2

Default: 0827'h

Table 24. MX-0Bh: IN1 Input Control - 2

Name	Bits	Read/Write	Reset State	Description
Reserved	15:13	R	0'h	Reserved
Manual_tri_in1	12	R/W	0'h	Manual Trigger For IN1 Port 0'b: Low to high trigger 1'b: High to low trigger
Capless_gat_en	11	R/W	1'h	Capless Power Gating with IN1 Control 0'b: Register control 1'b: Auto mode
reserved	10:8	R/W	0'h	Reserved
Reg_mode	7	R/W	0'h	IN1 Port Mode Control 0'b: Auto mode 1'b: Manual mode
reserved	6:0	R/W	27'h	Reserved

9.9. MX-0Ch: IN1 Port Control - 3

Default: 0000'h

Table 25. MX-0Ch: IN1 Input Control - 3

Name	Bits	Read/Write	Reset State	Description
Reserved	15:3	R	0'h	Reserved
In1_result	2:0	R	0'h	IN1 Port Final Status 001'b: Type1 010'b: Type2 100'b: Type3

9.10. MX-0Dh: IN2 Input Control

Default: 0000'h

Table 26. MX-0Dh: IN2 Input Control

Name	Bits	Read/Write	Reset State	Description
Reserved	15:12	R	0'h	Reserved
Sel_bst2	11:8	R/W	0'h	IN2 Boost Control (BST2) 0000'b: Bypass 0001'b: +20dB 0010'b: +24dB 0011'b: +30dB 0100'b: +35dB 0101'b: +40dB 0110'b: +44dB 0111'b: +50dB 1000'b: +52dB Others : Reserved
Reserved	7	R	0'h	Reserved
En_in2_df	6	R/W	0'h	IN2 Input Mode Control 0'b: Single Ended Mode 1'b: Differential Mode
Reserved	5:0	R	0'h	Reserved

9.11. MX-0Fh: INL & INR Volume Control

Default: 0808'h

Table 27. MX-0Fh: INL & INR Volume Control

Name	Bits	Read/Write	Reset State	Description
reserved	15:13	R	0'h	Reserved
Vol_inl	12:8	R/W	8'h	INL Channel Volume Control ❶ 00'h: +12dB ... 08'h: 0dB ... 1F'h: -34.5dB, with 1.5dB/step
Reserved	7:5	R	0'h	Reserved
Vol_inr	4:0	R/W	8'h	INR Channel Volume Control ❶ 00'h: +12dB ... 08'h: 0dB ... 1F'h: -34.5dB, with 1.5dB/step

❶ Volume Table:

DEC	HEX	Boost Gain	DEC	HEX	Boost Gain
0	0	12	16	10	-12
1	1	10.5	17	11	-13.5
2	2	9	18	12	-15
3	3	7.5	19	13	-16.5
4	4	6	20	14	-18
5	5	4.5	21	15	-19.5
6	6	3	22	16	-21
7	7	1.5	23	17	-22.5
8	8	0	24	18	-24
9	9	-1.5	25	19	-25.5
10	A	-3	26	1A	-27
11	B	-4.5	27	1B	-28.5
12	C	-6	28	1C	-30
13	D	-7.5	29	1D	-31.5
14	E	-9	30	1E	-33
15	F	-10.5	31	1F	-34.5

9.12. MX-19h: DACL1/R1 Digital Volume

Default: AFAF'h

Table 28. MX-19h: DACL1/R1 Digital Volume

Name	Bits	Read/Write	Reset State	Description
vol_dac1_l	15:8	R/W	AF'h	DAC1 Left Channel Digital Volume❶ 00'h: -65.625dB ... AF'h: 0dB, with 0.375dB/Step
vol_dac1_r	7:0	R/W	AF'h	DAC1 Right Channel Digital Volume❶ 00'h: -65.625dB ... AF'h: 0dB, with 0.375dB/Step

9.13. MX-1Ah: DACL2/R2 Digital Volume

Default: AFAF'h

Table 29. MX-1Ah: DACL2/R2 Digital Volume

Name	Bits	Read/Write	Reset State	Description
vol_dac2_l	15:8	R/W	AF'h	DAC2 Left Channel Digital Volume❶ 00'h: -65.625dB ... AF'h: 0dB, with 0.375dB/Step
vol_dac2_r	7:0	R/W	AF'h	DAC2 Right Channel Digital Volume❶ 00'h: -65.625dB ... AF'h: 0dB, with 0.375dB/Step

❶ Volume Table:

DEC	HEX	Boost Gain	DEC	HEX	Boost Gain	DEC	HEX	Boost Gain	DEC	HEX	Boost Gain	DEC	HEX	Boost Gain
0	0	-65.625	53	35	-45.75	106	6A	-25.875	159	9F	-6	212	D4	
1	1	-65.25	54	36	-45.375	107	6B	-25.5	160	A0	-5.625	213	D5	
2	2	-64.875	55	37	-45	108	6C	-25.125	161	A1	-5.25	214	D6	
3	3	-64.5	56	38	-44.625	109	6D	-24.75	162	A2	-4.875	215	D7	
4	4	-64.125	57	39	-44.25	110	6E	-24.375	163	A3	-4.5	216	D8	
5	5	-63.75	58	3A	-43.875	111	6F	-24	164	A4	-4.125	217	D9	
6	6	-63.375	59	3B	-43.5	112	70	-23.625	165	A5	-3.75	218	DA	
7	7	-63	60	3C	-43.125	113	71	-23.25	166	A6	-3.375	219	DB	

8	8	-62.625	61	3D	-42.75	114	72	-22.875	167	A7	-3	220	DC	
9	9	-62.25	62	3E	-42.375	115	73	-22.5	168	A8	-2.625	221	DD	
10	A	-61.875	63	3F	-42	116	74	-22.125	169	A9	-2.25	222	DE	
11	B	-61.5	64	40	-41.625	117	75	-21.75	170	AA	-1.875	223	DF	
12	C	-61.125	65	41	-41.25	118	76	-21.375	171	AB	-1.5	224	E0	
13	D	-60.75	66	42	-40.875	119	77	-21	172	AC	-1.125	225	E1	
14	E	-60.375	67	43	-40.5	120	78	-20.625	173	AD	-0.75	226	E2	
15	F	-60	68	44	-40.125	121	79	-20.25	174	AE	-0.375	227	E3	
16	10	-59.625	69	45	-39.75	122	7A	-19.875	175	AF	0	228	E4	
17	11	-59.25	70	46	-39.375	123	7B	-19.5	176	B0		229	E5	
18	12	-58.875	71	47	-39	124	7C	-19.125	177	B1		230	E6	
19	13	-58.5	72	48	-38.625	125	7D	-18.75	178	B2		231	E7	
20	14	-58.125	73	49	-38.25	126	7E	-18.375	179	B3		232	E8	
21	15	-57.75	74	4A	-37.875	127	7F	-18	180	B4		233	E9	
22	16	-57.375	75	4B	-37.5	128	80	-17.625	181	B5		234	EA	
23	17	-57	76	4C	-37.125	129	81	-17.25	182	B6		235	EB	
24	18	-56.625	77	4D	-36.75	130	82	-16.875	183	B7		236	EC	
25	19	-56.25	78	4E	-36.375	131	83	-16.5	184	B8		237	ED	
26	1A	-55.875	79	4F	-36	132	84	-16.125	185	B9		238	EE	
27	1B	-55.5	80	50	-35.625	133	85	-15.75	186	BA		239	EF	
28	1C	-55.125	81	51	-35.25	134	86	-15.375	187	BB		240	F0	
29	1D	-54.75	82	52	-34.875	135	87	-15	188	BC		241	F1	
30	1E	-54.375	83	53	-34.5	136	88	-14.625	189	BD		242	F2	
31	1F	-54	84	54	-34.125	137	89	-14.25	190	BE		243	F3	
32	20	-53.625	85	55	-33.75	138	8A	-13.875	191	BF		244	F4	
33	21	-53.25	86	56	-33.375	139	8B	-13.5	192	C0		245	F5	
34	22	-52.875	87	57	-33	140	8C	-13.125	193	C1		246	F6	
35	23	-52.5	88	58	-32.625	141	8D	-12.75	194	C2		247	F7	
36	24	-52.125	89	59	-32.25	142	8E	-12.375	195	C3		248	F8	
37	25	-51.75	90	5A	-31.875	143	8F	-12	196	C4		249	F9	
38	26	-51.375	91	5B	-31.5	144	90	-11.625	197	C5		250	FA	
39	27	-51	92	5C	-31.125	145	91	-11.25	198	C6		251	FB	
40	28	-50.625	93	5D	-30.75	146	92	-10.875	199	C7		252	FC	
41	29	-50.25	94	5E	-30.375	147	93	-10.5	200	C8		253	FD	
42	2A	-49.875	95	5F	-30	148	94	-10.125	201	C9		254	FE	
43	2B	-49.5	96	60	-29.625	149	95	-9.75	202	CA		255	FF	

44	2C	-49.125	97	61	-29.25	150	96	-9.375	203	CB				
45	2D	-48.75	98	62	-28.875	151	97	-9	204	CC				
46	2E	-48.375	99	63	-28.5	152	98	-8.625	205	CD				
47	2F	-48	100	64	-28.125	153	99	-8.25	206	CE				
48	30	-47.625	101	65	-27.75	154	9A	-7.875	207	CF				
49	31	-47.25	102	66	-27.375	155	9B	-7.5	208	D0				
50	32	-46.875	103	67	-27	156	9C	-7.125	209	D1				
51	33	-46.5	104	68	-26.625	157	9D	-6.75	210	D2				
52	34	-46.125	105	69	-26.25	158	9E	-6.375	211	D3				

9.14. MX-1Bh: DACL2/R2 Mute/Un-Mute Control

Default: 0000'h

Table 30. MX-1Bh: DACL2/R2 Mute/Un-Mute Control

Name	Bits	Read/Write	Reset State	Description
reserved	15:14	R	0'h	Reserved
Mu_dac2_l	13	R/W	0'h	Mute Control for Left DAC2 Volume 0'b: Un-Mute 1'b: Mute
Mu_dac2_r	12	R/W	0'h	Mute Control for Right DAC2 Volume 0'b: Un-Mute 1'b: Mute
reserved	11:7	R	0'h	Reserved
Sel_dacl2	6:4	R/W	1'h	Select DACL2 Data Source 000'b: IF1_DAC2_L 001'b: IF2_DAC_L 010'b: Reserved 011'b: Mono_ADC_Mixer_L Others: Reserved
reserved	3	R	0'h	Reserved

Sel_dacr2	2:0	R/W	1'h	Select DACR2 Data Source 000'b: IF1_DAC2_R 001'b: IF2_DAC_R 010'b: Reserved 011'b: Mono_ADC_Mixer_R 100'b: Haptic generator Others: Reserved
-----------	-----	-----	-----	--

9.15. MX-1Ch: Stereo1 ADC Digital Volume Control

Default: 2F2F'h

Table 31. MX-1Ch: Stereo1 ADC Digital Volume Control

Name	Bits	Read/Write	Reset State	Description
Mu_adc_vol_l	15	R/W	0'h	Mute Control for Stereo1 ADC Left Volume Channel 0'b: Un-Mute 1'b: Mute
Ad_gain_l	14:8	R/W	2F'h	Stereo1 ADC Left Channel Volume Control 00'h: -17.625dB ... 2F'h: 0dB ... 7F'h: +30dB, with 0.375dB/Step
Mu_adc_vol_r	7	R/W	0'h	Mute Control for Stereo1 ADC Right Volume Channel 0'b: Un-Mute 1'b: Mute
Ad_gain_r	6:0	R/W	2F'h	Stereo1 ADC Right Channel Volume Control 00'h: -17.625dB ... 2F'h: 0dB ... 7F'h: +30dB, with 0.375dB/Step

9.16. MX-1Dh: Mono ADC Digital Volume Control

Default: 2F2F'h

Table 32. MX-1Dh: Mono ADC Digital Volume Control

Name	Bits	Read/Write	Reset State	Description
Mu_mono_adc_vol_l	15	R/W	0'h	Mute Control for Mono ADC Left Volume Channel 0'b: Un-Mute 1'b: Mute
Mono_ad_gain_l	14:8	R/W	2F'h	Mono ADC Left Channel Volume Control ① 00'h: -17.625dB ... 2F'h: 0dB ... 7F'h: +30dB, with 0.375dB/Step
Mu_mono_adc_vol_r	7	R/W	0'h	Mute Control for Mono ADC Right Volume Channel 0'b: Un-Mute 1'b: Mute
Mono_ad_gain_r	6:0	R/W	2F'h	Mono ADC Right Channel Volume Control ① 00'h: -17.625dB ... 2F'h: 0dB ... 7F'h: +30dB, with 0.375dB/Step

① Volume Table:

DEC	HEX	Boost Gain	DEC	HEX	Boost Gain	DEC	HEX	Boost Gain	DEC	HEX	Boost Gain	DEC	HEX	Boost Gain
0	0	-17.625	26	1A	-7.875	52	34	1.875	78	4E	11.625	104	68	21.375
1	1	-17.25	27	1B	-7.5	53	35	2.25	79	4F	12	105	69	21.75
2	2	-16.875	28	1C	-7.125	54	36	2.625	80	50	12.375	106	6A	22.125
3	3	-16.5	29	1D	-6.75	55	37	3	81	51	12.75	107	6B	22.5
4	4	-16.125	30	1E	-6.375	56	38	3.375	82	52	13.125	108	6C	22.875
5	5	-15.75	31	1F	-6	57	39	3.75	83	53	13.5	109	6D	23.25
6	6	-15.375	32	20	-5.625	58	3A	4.125	84	54	13.875	110	6E	23.625
7	7	-15	33	21	-5.25	59	3B	4.5	85	55	14.25	111	6F	24
8	8	-14.625	34	22	-4.875	60	3C	4.875	86	56	14.625	112	70	24.375
9	9	-14.25	35	23	-4.5	61	3D	5.25	87	57	15	113	71	24.75
10	A	-13.875	36	24	-4.125	62	3E	5.625	88	58	15.375	114	72	25.125
11	B	-13.5	37	25	-3.75	63	3F	6	89	59	15.75	115	73	25.5
12	C	-13.125	38	26	-3.375	64	40	6.375	90	5A	16.125	116	74	25.875
13	D	-12.75	39	27	-3	65	41	6.75	91	5B	16.5	117	75	26.25
14	E	-12.375	40	28	-2.625	66	42	7.125	92	5C	16.875	118	76	26.625
15	F	-12	41	29	-2.25	67	43	7.5	93	5D	17.25	119	77	27
16	10	-11.625	42	2A	-1.875	68	44	7.875	94	5E	17.625	120	78	27.375

17	11	-11.25	43	2B	-1.5	69	45	8.25	95	5F	18	121	79	27.75
18	12	-10.875	44	2C	-1.125	70	46	8.625	96	60	18.375	122	7A	28.125
19	13	-10.5	45	2D	-0.75	71	47	9	97	61	18.75	123	7B	28.5
20	14	-10.125	46	2E	-0.375	72	48	9.375	98	62	19.125	124	7C	28.875
21	15	-9.75	47	2F	0	73	49	9.75	99	63	19.5	125	7D	29.25
22	16	-9.375	48	30	0.375	74	4A	10.125	100	64	19.875	126	7E	29.625
23	17	-9	49	31	0.75	75	4B	10.5	101	65	20.25	127	7F	30
24	18	-8.625	50	32	1.125	76	4C	10.875	102	66	20.625			
25	19	-8.25	51	33	1.5	77	4D	11.25	103	67	21			

9.17. MX-1Eh: ADC Digital Boost Gain Control

Default: 0000'h

Table 33. MX-1Eh: ADC Digital Boost Gain Control

Name	Bits	Read/Write	Reset State	Description
Stereo1_ad_boost_gain_l	15:14	R/W	0'h	Stereo1 ADC Left Channel Digital Boost Gain 00'b: 0dB 01'b: 12dB 10'b: 24dB 11'b: 36dB
Stereo1_ad_boost_gain_r	13:12	R/W	0'h	Stereo1 ADC Right Channel Digital Boost Gain 00'b: 0dB 01'b: 12dB 10'b: 24dB 11'b: 36dB
Stereo1_ad_comp_gain	11:10	R/W	0'h	Stereo1 ADC Compensation Gain 00'b: 0dB 01'b: 1dB 10'b: 2dB 11'b: 3dB
reserved	9:0	R	0'h	Reserved

9.18. MX-20h: Mono ADC Digital Boost Gain Control

Default: 0000'h

Table 34. MX-20h: Mono ADC Digital Boost Gain Control

Name	Bits	Read/Write	Reset State	Description
mono_ad_boost_ga in_l	15:14	R/W	0'h	Mono ADC Left Channel Digital Boost Gain 00'b: 0dB 01'b: 12dB 10'b: 24dB 11'b: 36dB
mono_ad_boost_ga in_r	13:12	R/W	0'h	Mono ADC Right Channel Digital Boost Gain 00'b: 0dB 01'b: 12dB 10'b: 24dB 11'b: 36dB
mono_ad_comp_ga in	11:10	R/W	0'h	Mono ADC Compensation Gain 00'b: 0dB 01'b: 1dB 10'b: 2dB 11'b: 3dB
Reserved	9:0	R	0'h	Reserved

9.19. MX-27h: Stereo1 ADC Digital Mixer Control

Default: 7060'h

Table 35. MX-27h: Stereo1 ADC Digital Mixer Control

Name	Bits	Read/Write	Reset State	Description
reserved	15	R	0'h	Reserved
mu_stereo1_adc1	14	R/W	1'h	Mute Source 1 to Stereo1 ADC Left Channel 0'b: UnMute 1'b: Mute
mu_stereo1_adc2	13	R/W	1'h	Mute Source 2 to Stereo1 ADC Left Channel 0'b: UnMute 1'b: Mute
sel_stereo1_adc1	12	R/W	1'h	Select Stereo1 ADC L/R Channel Source 1 0'b: DAC_MIXL / DAC_MIXR 1'b: ADC1
sel_stereo1_adc2	11	R/W	0'h	Select Stereo1 ADC L/R Channel Source 2 0'b: DAC_MIXL / DAC_MIXR 1'b: DMIC1/DMIC2

reserved	10:9	R	0'h	Reserved
Sel_stereo1_dmic	8	R/W	0'h	Select Stereo1 DMIC Source 0'b: DMIC1 1'b: DMIC2
reserved	7	R	0'h	Reserved
mu_stereo1_adcr1	6	R/W	1'h	Mute Source 1 to Stereo1 ADC Right Channel 0'b:UnMute 1'b:Mute
mu_stereo1_adcr2	5	R/W	1'h	Mute Source 2 to Stereo1 ADC Right Channel 0'b:UnMute 1'b:Mute
reserved	4:0	R	0'h	reserved

9.20. MX-28h: Mono ADC Digital Mixer Control

Default: 7070'h

Table 36. MX-28h: Mono ADC Digital Mixer Control

Name	Bits	Read/Write	Reset State	Description
reserved	15	R	0'h	Reserved
mu_mono_adcl1	14	R/W	1'h	Mute Source 1 to Mono ADC Left channel 0'b:UnMute 1'b:Mute
mu_mono_adcl2	13	R/W	1'h	Mute Source 2 to Mono ADC Left channel 0'b:UnMute 1'b:Mute
sel_mono_adcl1	12	R/W	1'h	Select Mono ADC Left channel source 1 0'b: Mono_DAC_Mixer_L 1'b: ADC1
sel_mono_adcl2	11	R/W	0'h	Select Mono ADC Left channel source 2 0'b: Mono_DAC_Mixer_L 1'b: DMIC1_L or DMIC2_L
reserved	10:9	R	0'h	Reserved
Sel_mono_dmic_1	8	R/W	0'h	Select Mono Left Channel DMIC Source 0'b: DMIC1_L 1'b: DMIC2_L
reserved	7	R	0'h	Reserved
mu_mono_adcr1	6	R/W	1'h	Mute Source 1 to Mono ADC Right channel 0'b:UnMute 1'b:Mute
mu_mono_adcr2	5	R/W	1'h	Mute Source 2 to Mono ADC Right channel 0'b:UnMute 1'b:Mute
sel_mono_adcr1	4	R/W	1'h	Select Mono ADC Right channel source 1 0'b: Mono_DAC_Mixer_R 1'b: ADC2
sel_mono_adcr2	3	R/W	0'h	Select Mono ADC Right channel source 2 0'b: Mono_DAC_Mixer_R 1'b: DMIC1_R or DMIC2_R

Name	Bits	Read/Write	Reset State	Description
reserved	2	R	0'h	Reserved
Sel_mono_dmic_r	1:0	R/W	0'h	Select Mono Right Channel DMIC Source 0'b: DMIC1_R 1'b: DMIC2_R

9.21. MX-29h: Stereo ADC to DAC Digital Mixer Control

Default: 8080'h

Table 37. MX-29h: Stereo ADC to DAC Digital Mixer Control

Name	Bits	Read/Write	Reset State	Description
Mu_stereo1_adc_mixer_l	15	R/W	1'h	Mute Stereo1 ADC to DAC1 Left Channel 0'b: UnMute 1'b: Mute
Mu_dac1_l	14	R/W	0'h	Mute IF1 DAC Left Channel 0'b: UnMute 1'b: Mute
reserved	13:12	R	0'h	Reserved
Sel_dacr1	11:10	R/W	0'h	DACR1 Source Selection 00'b: IF1_DAC1_R 01'b: IF2_DAC_R 10'b: Reserved 11'b: Reserved
Sel_dacl1	9:8	R/W	0'h	DACL1 Source Selection 00'b: IF1_DAC1_L 01'b: IF2_DAC_L 10'b: Reserved 11'b: Reserved
Mu_stereo1_adc_mixer_r	7	R/W	1'h	Mute Stereo1 ADC to DAC1 Right Channel 0'b: UnMute 1'b: Mute
Mu_dac1_r	6	R/W	0'h	Mute IF1 DAC Right Channel 0'b: UnMute 1'b: Mute
reserved	5:0	R	0'h	reserved

9.22. MX-2Ah: Stereo DAC Digital Mixer Control

Default: 5656'h

Table 38. MX-2Ah: Stereo DAC Digital Mixer Control

Name	Bits	Read/Write	Reset State	Description
reserved	15	R	0'h	Reserved
mu_stereo_dacl1_mix1	14	R/W	1'h	Mute Stereo DAC1 Left channel 0'b:UnMute 1'b:Mute
gain_dacl1_to_stereo_l	13	R/W	0'h	Gain Control for DACL1 to Stereo Left Mixer 0'b: 0dB 1'b: -6dB
mu_stereo_dacl2_mix1	12	R/W	1'h	Mute Stereo DAC2 Left channel 0'b:UnMute 1'b:Mute
gain_dacl2_to_stereo_l	11	R/W	0'h	Gain Control for DACL2 to Stereo Left Mixer 0'b: 0dB 1'b: -6dB
reserved	10	R/W	1'h	Reserved
mu_stereo_dacr1_mix1	9	R/W	1'h	Mute Stereo DAC1 Right channel to Left Mixer 0'b:UnMute 1'b:Mute
gain_dacr1_to_stereo_l	8	R/W	0'h	Gain Control for DACR1 to Stereo Left Mixer 0'b: 0dB 1'b: -6dB
reserved	7	R	0'h	reserved
mu_stereo_dacr1_mixr	6	R/W	1'h	Mute Stereo DAC1 Right channel 0'b:UnMute 1'b:Mute
gain_dacr1_to_stereo_r	5	R/W	0'h	Gain Control for DACR1 to Stereo Right Mixer 0'b: 0dB 1'b: -6dB
mu_stereo_dacr2_mixr	4	R/W	1'h	Mute Stereo DAC2 Right channel 0'b:UnMute 1'b:Mute
gain_dacr2_to_stereo_r	3	R/W	0'h	Gain Control for DACR2 to Stereo Right Mixer 0'b: 0dB 1'b: -6dB
Reserved	2	R/W	1'h	Reserved
mu_stereo_dacl1_mixr	1	R/W	1'h	Mute Stereo DAC1 Left channel to Right Mixer 0'b:UnMute 1'b:Mute
gain_dacl1_to_stereo_r	0	R/W	0'h	Gain Control for DACL1 to Stereo Right Mixer 0'b: 0dB 1'b: -6dB

9.23. MX-2Bh: Mono DAC Digital Mixer Control

Default: 5454'h

Table 39. MX-2Bh: Mono DAC Digital Mixer Control

Name	Bits	Read/Write	Reset State	Description
reserved	15	R	0'h	Reserved
mu_mono_dacl1_mix1	14	R/W	1'h	Mute DAC1 Left channel to Mono DAC Left Mixer 0'b:UnMute 1'b:Mute
gain_mono_l_dacl1	13	R/W	0'h	Gain Control for DAC1 Left channel to Mono DAC Left Mixer 0'b: 0dB 1'b: -6dB
mu_mono_dacl2_mix1	12	R/W	1'h	Mute DAC2 Left channel to Mono DAC Left Mixer 0'b:UnMute 1'b:Mute
gain_mono_l_dacl2	11	R/W	0'h	Gain Control for DAC2 Left channel to Mono DAC Left Mixer 0'b: 0dB 1'b: -6dB
mu_mono_dacr2_mix1	10	R/W	1'h	Mute DAC2 Right channel to Mono DAC Left Mixer 0'b:UnMute 1'b:Mute
gain_mono_l_dacr2	9	R/W	0'h	Gain Control for DAC2 Right channel to Mono DAC Left Mixer 0'b: 0dB 1'b: -6dB
reserved	8:7	R	0'h	reserved
mu_mono_dacr1_mixr	6	R/W	1'h	Mute DAC1 Right channel to Mono DAC Right Mixer 0'b:UnMute 1'b:Mute
gain_mono_r_dacr1	5	R/W	0'h	Gain Control for DAC1 Right channel to Mono DAC Right Mixer 0'b: 0dB 1'b: -6dB
mu_mono_dacr2_mixr	4	R/W	1'h	Mute DAC2 Right channel to Mono DAC Right Mixer 0'b:UnMute 1'b:Mute
gain_mono_r_dacr2	3	R/W	0'h	Gain Control for DAC2 Right channel to Mono DAC Right Mixer 0'b: 0dB 1'b: -6dB
mu_mono_dacl2_mixr	2	R/W	1'h	Mute DAC2 Left channel to Mono DAC Right Mixer 0'b:UnMute 1'b:Mute
gain_mono_r_dacl2	1	R/W	0'h	Gain Control for DAC2 Left channel to Mono DAC Right Mixer 0'b: 0dB 1'b: -6dB
reserved	0	R	0'h	reserved

9.24. MX-2Ch: DAC Digital Mixer Control

Default: AAA0'h

Table 40. MX-2Ch: DAC Digital Mixer Control

Name	Bits	Read/Write	Reset State	Description
Mu_stereomixl_to_dacmixl	15	R/W	1'h	Mute Stereo_DAC_Mixer_L to DAC_MIXL 0'b: UnMute 1'b: Mute
gain_stereomixl_to_dacmixl	14	R/W	0'h	Gain Control for Stereo_DAC_Mixer_L to DAC_MIXL 0'b: 0dB 1'b: -6dB
Mu_dacl2_to_dacmixl	13	R/W	1'h	Mute DACL2 to DAC_MIXL 0'b: UnMute 1'b: Mute
gain_dacl2_to_dacmixl	12	R/W	0'h	Gain Control for DACL2 to DAC_MIXL 0'b: 0dB 1'b: -6dB
Mu_stereomixr_to_dacmixr	11	R/W	1'h	Mute Stereo_DAC_Mixer_R to DAC_MIXR 0'b: UnMute 1'b: Mute
gain_stereomixr_to_dacmixr	10	R/W	0'h	Gain Control for Stereo_DAC_Mixer_R to DAC_MIXR 0'b: 0dB 1'b: -6dB
Mu_dacr2_to_dacmixr	9	R/W	1'h	Mute DACR2 to DAC_MIXR 0'b: UnMute 1'b: Mute
gain_dacr2_to_dacmixr	8	R/W	0'h	Gain Control for DACR2 to DAC_MIXR 0'b: 0dB 1'b: -6dB
Mu_dacr2_to_dacmixl	7	R/W	1'h	Mute DACR2 to DAC_MIXL 0'b: UnMute 1'b: Mute
gain_dacr2_to_dacmixl	6	R/W	0'h	Gain Control for DACR2 to DAC_MIXL 0'b: 0dB 1'b: -6dB
Mu_dacl2_to_dacmixr	5	R/W	1'h	Mute DACL2 to DAC_MIXR 0'b: UnMute 1'b: Mute
gain_dacl2_to_dacmixr	4	R/W	0'h	Gain Control for DACL2 to DAC_MIXR 0'b: 0dB 1'b: -6dB
reserved	3:0	R	0'h	Reserved

9.25. MX-2Fh: Interface DAC/ADC Data Control

Default: 1002'h

Table 41. MX-2Fh: Interface DAC/ADC Data Control

Name	Bits	Read/Write	Reset State	Description
Reserved	15:14	R	0'h	Reserved
Sel_if2_adc_data_in	13:12	R/W	1'h	Select Interface2 ADC Data Input 00'b: IF_ADC1 01'b: IF_ADC2 10'b: Reserved 11'b: Reserved
sel_if2_dac_data	11:10	R/W	0'h	Select Interface2 DAC Data Swap 00'b: L/R 01'b: R/L 10'b: L/L 11'b: R/R
sel_if2_adc_data	9:8	R/W	0'h	Select Interface2 ADC Data Swap 00'b: L/R 01'b: R/L 10'b: L/L 11'b: R/R
reserved	7:0	R/W	2'h	Reserved

9.26. MX-31h: PDM Interface Control

Default: 5000'h

Table 42. MX-31h: PDM Interface Control

Name	Bits	Read/Write	Reset State	Description
sel_pdm_l	15	R/W	0'h	Select PDM Interface Left Channel Data Source 0'b: Mono_DAC_MIXL 1'b: Stereo_DAC_MIXL
mu_pdm_l	14	R/W	1'h	Mute PDM Left Channel Data 0'b: UnMute 1'b: Mute
sel_pdm_r	13	R/W	0'h	Select PDM Interface Right Channel Data Source 0'b: Mono_DAC_MIXR 1'b: Stereo_DAC_MIXR
mu_pdm_r	12	R/W	1'h	Mute PDM Right Channel Data 0'b: UnMute 1'b: Mute
Reserved	11:0	R	F00'h	Reserved

9.27. MX-3Bh: RECMIXL Control 1

Default: 0000'h

Table 43. MX-3Bh: RECMIXL Control 1

Name	Bits	Read/Write	Reset State	Description
gain_hpovoll_recmixl	15:13	R/W	0'h	Gain Control for HPOVOLL to REC Left Mixer 000'b: 0dB 001'b: -3dB 010'b: -6dB 011'b: -9dB 100'b: -12dB 101'b: -15dB 110'b: -18dB
gain_inl_recmixl	12:10	R/W	0'h	Gain Control for INL1 to REC Left Mixer 000'b: 0dB 001'b: -3dB 010'b: -6dB 011'b: -9dB 100'b: -12dB 101'b: -15dB 110'b: -18dB
reserved	9:4	R/W	0'h	Reserved
gain_bst2_recmixl	3:1	R/W	0'h	Gain Control for Boost 2 to REC Left Mixer 000'b: 0dB 001'b: -3dB 010'b: -6dB 011'b: -9dB 100'b: -12dB 101'b: -15dB 110'b: -18dB
reserved	0	R	0'h	reserved

9.28. MX-3Ch: RECMIXL Control 2

Default: 007F'h

Table 44. MX-3Ch: RECMIXL Control 2

Name	Bits	Read/Write	Reset State	Description
gain_bst1_recmixl	15:13	R/W	0'h	Gain Control for Boost 1 to REC Left Mixer 000'b: 0dB 001'b: -3dB 010'b: -6dB 011'b: -9dB 100'b: -12dB 101'b: -15dB 110'b: -18dB
gain_outvoll_recmixl	12:10	R/W	0'h	Gain Control for OUTVOLL to REC Left Mixer 000'b: 0dB 001'b: -3dB 010'b: -6dB 011'b: -9dB 100'b: -12dB 101'b: -15dB 110'b: -18dB
reserved	9:6	R	1'h	Reserved
Mu_inl_recmixl	5	R/W	1'h	INL1 to RECMIXL Mute Control 0'b : Un-Mute 1'b: Mute (-∞ dB)
Mu_hpovoll_recmixl	4	R/W	1'h	HPOVOLL to RECMIXL Mute Control 0'b : Un-Mute 1'b: Mute (-∞ dB)
reserved	3	R/W	1'h	Reserved
Mu_bst2_recmixl	2	R/W	1'h	MIC BST2 to RECMIXL Mute Control 0'b : Un-Mute 1'b: Mute (-∞ dB)
Mu_bst1_recmixl	1	R/W	1'h	MIC BST1 to RECMIXL Mute Control 0'b : Un-Mute 1'b: Mute (-∞ dB)

Name	Bits	Read/Write	Reset State	Description
Mu_outvoll_recmixl	0	R/W	1'h	OUTVOLL to RECMIXL Mute Control 0'b : Un-Mute 1'b: Mute (-∞ dB)

9.29. MX-3Dh: RECMIXR Control 1

Default: 0000'h

Table 45. MX-3Dh: RECMIXR Control 1

Name	Bits	Read/Write	Reset State	Description
gain_hpovolr_recmixr	15:13	R/W	0'h	Gain Control for HPOVOLR to REC Right Mixer 000'b: 0dB 001'b: -3dB 010'b: -6dB 011'b: -9dB 100'b: -12dB 101'b: -15dB 110'b: -18dB
gain_inr_recmixr	12:10	R/W	0'h	Gain Control for INR1 to REC Right Mixer 000'b: 0dB 001'b: -3dB 010'b: -6dB 011'b: -9dB 100'b: -12dB 101'b: -15dB 110'b: -18dB
reserved	9:4	R/W	0'h	Reserved
gain_bst2_recmixr	3:1	R/W	0'h	Gain Control for Boost 2 to REC Right Mixer 000'b: 0dB 001'b: -3dB 010'b: -6dB 011'b: -9dB 100'b: -12dB 101'b: -15dB 110'b: -18dB
reserved	0	R	0'h	reserved

9.30. MX-3Eh: RECMIXR Control 2

Default: 007F'h

Table 46. MX-3Eh: RECMIXR Control 2

Name	Bits	Read/Write	Reset State	Description
gain_bst1_recmixr	15:13	R/W	0'h	Gain Control for Boost 1 to REC Right Mixer 000'b: 0dB 001'b: -3dB 010'b: -6dB 011'b: -9dB 100'b: -12dB 101'b: -15dB 110'b: -18dB
gain_outvolr_recmixr	12:10	R/W	0'h	Gain Control for OUTVOLR to REC Right Mixer 000'b: 0dB 001'b: -3dB 010'b: -6dB 011'b: -9dB 100'b: -12dB 101'b: -15dB 110'b: -18dB
reserved	9:6	R	1'h	Reserved
Mu_inr_recmixr	5	R/W	1'h	INR1 to RECMIXR Mute Control 0'b : Un-Mute 1'b: Mute (-∞ dB)
Mu_hpovolr_recmixr	4	R/W	1'h	HPOVOLR to RECMIXR Mute Control 0'b : Un-Mute 1'b: Mute (-∞ dB)
reserved	3	R/W	1'h	Reserved

Name	Bits	Read/Write	Reset State	Description
Mu_bst2_recmixr	2	R/W	1'h	MIC BST2 to RECMIXR Mute Control 0'b : Un-Mute 1'b: Mute (-∞ dB)
Mu_bst1_recmixr	1	R/W	1'h	MIC BST1 to RECMIXR Mute Control 0'b : Un-Mute 1'b: Mute (-∞ dB)
Mu_outvolr_recmixr	0	R/W	1'h	OUTVOLR to RECMIXR Mute Control 0'b : Un-Mute 1'b: Mute (-∞ dB)

9.31. MX-3Fh: HPMIXL Control

Default: 0000'h

Table 47. MX-3Fh: HPMIXL Control

Name	Bits	Read/Write	Reset State	Description
reserved	15:10	R	0'h	Reserved
gain_dacl1_hpmixl	9:8	R/W	0'h	Gain Control for DACL1 to HPMIXL 00'b: 0dB 01'b: -3dB 10'b: -6dB 11'b: -9dB
gain_dacl2_hpmixl	7:6	R/W	0'h	Gain Control for DACL2 to HPMIXL 00'b: 0dB 01'b: -3dB 10'b: -6dB 11'b: -9dB
gain_inl_hpmixl	5:4	R/W	0'h	Gain Control for INL to HPMIXL 00'b: 0dB 01'b: -3dB 10'b: -6dB 11'b: -9dB
reserved	3:2	R	0'h	Reserved
gain_bst1_hpmixl	1:0	R/W	0'h	Gain Control for BST1 to HPMIXL 00'b: 0dB 01'b: -3dB 10'b: -6dB 11'b: -9dB

9.32. MX-40h HPMIXL Control

Default: 001F'h

Table 48. MX-40h: HPMIXL Control

Name	Bits	Read/Write	Reset State	Description
reserved	15:5	R	0'h	Reserved
Mu_bst1_hpmixl	4	R/W	1'h	BST1 to HPMIXL Mute Control 0'b : Un-Mute 1'b: Mute (-∞ dB)
reserved	3	R/W	1'h	Reserved
Mu_inl_hpmixl	2	R/W	1'h	INL to HPMIXL Mute Control 0'b : Un-Mute 1'b: Mute (-∞ dB)
Mu_dacl2_hpmixl	1	R/W	1'h	DACL2 to HPMIXL Mute Control 0'b : Un-Mute 1'b: Mute (-∞ dB)
Mu_dacl1_hpmixl	0	R/W	1'h	DACL1 to HPMIXL Mute Control 0'b : Un-Mute 1'b: Mute (-∞ dB)

9.33. MX-41h: HPMIXR Control

Default: 0000'h

Table 49. MX-41h: HPMIXR Control

Name	Bits	Read/Write	Reset State	Description
reserved	15:10	R	0'h	Reserved
gain_dacr1_hpmixr	9:8	R/W	0'h	Gain Control for DACR1 to HPMIXR 00'b: 0dB 01'b: -3dB 10'b: -6dB 11'b: -9dB
gain_dacr2_hpmixr	7:6	R/W	0'h	Gain Control for DACR2 to HPMIXR 00'b: 0dB 01'b: -3dB 10'b: -6dB 11'b: -9dB
gain_inr_hpmixl	5:4	R/W	0'h	Gain Control for INR to HPMIXR 00'b: 0dB 01'b: -3dB 10'b: -6dB 11'b: -9dB
reserved	3:2	R	0'h	Reserved
gain_bst2_hpmixr	1:0	R/W	0'h	Gain Control for BST2 to HPMIXR 00'b: 0dB 01'b: -3dB 10'b: -6dB 11'b: -9dB

9.34. MX-42h HPMIXR Control

Default: 001F'h

Table 50. MX-42h: HPMIXR Control

Name	Bits	Read/Write	Reset State	Description
reserved	15:5	R	0'h	Reserved
Mu_bst2_hpmixr	4	R/W	1'h	BST2 to HPMIXR Mute Control 0'b : Un-Mute 1'b: Mute (-∞ dB)
reserved	3	R/W	1'h	Reserved
Mu_inr_hpmixr	2	R/W	1'h	INR to HPMIXR Mute Control 0'b : Un-Mute 1'b: Mute (-∞ dB)
Mu_dacr2_hpmixr	1	R/W	1'h	DACR2 to HPMIXR Mute Control 0'b : Un-Mute 1'b: Mute (-∞ dB)
Mu_dacr1_hpmixr	0	R/W	1'h	DACR1 to HPMIXR Mute Control 0'b : Un-Mute 1'b: Mute (-∞ dB)

9.35. MX-45h: HPOMIX Control

Default: 6000'h

Table 51. MX-45h: HPOMIX Control

Name	Bits	Read/Write	Reset State	Description
reserved	15	R	0'h	Reserved
Mu_dac1_hpo	14	R/W	1'h	DAC1 to HPO Mute Control 0'b: Un-Mute 1'b: Mute (-∞ dB)
Mu_hpvol_hpo	13	R/W	1'h	HPOVOL to HPO Mute Control 0'b: Un-Mute 1'b: Mute (-∞ dB)
En_bst_hp	12	R/W	0'h	HPO Gain Control 0'b: 0dB 1'b: -6dB
reserved	11:0	R	0'h	Reserved

9.36. MX-46h: SPKMIXL Control

Default: 003E'h

Table 52. MX-46h: SPKMIXL Control

Name	Bits	Read/Write	Reset State	Description
gain_bst1_spkmixl	15:14	R/W	0'h	Gain Control for BST1 to SPKMIXL 00'b: 0dB 01'b: -3dB 10'b: -6dB 11'b: -9dB
gain_inl_spkmixl	13:12	R/W	0'h	Gain Control for INL to SPKMIXL 00'b: 0dB 01'b: -3dB 10'b: -6dB 11'b: -9dB
gain_dacl1_spkmixl	11:10	R/W	0'h	Gain Control for DAACL1 to SPKMIXL 00'b: 0dB 01'b: -3dB 10'b: -6dB 11'b: -9dB
gain_dacl2_spkmixl	9:8	R/W	0'h	Gain Control for DAACL2 to SPKMIXL 00'b: 0dB 01'b: -3dB 10'b: -6dB 11'b: -9dB
Reserved	7:6	R/W	0'h	Reserved
Mu_bst1_spkmixl	5	R/W	1'h	BST1 to SPKMIXL Mute Control 0'b : Un-Mute 1'b: Mute (-∞ dB)
Reserved	4	R/W	1'h	Reserved
Mu_inl_spkmixl	3	R/W	1'h	INL to SPKMIXL Mute Control 0'b : Un-Mute 1'b: Mute (-∞ dB)
Mu_dacl2_spkmixl	2	R/W	1'h	DAACL2 to SPKMIXL Mute Control 0'b : Un-Mute 1'b: Mute (-∞ dB)
Mu_dacl1_spkmixl	1	R/W	1'h	DAACL1 to SPKMIXL Mute Control 0'b : Un-Mute 1'b: Mute (-∞ dB)
Reserved	0	R	0'h	Reserved

9.37. MX-47h: SPKMIXR Control

Default: 003E'h

Table 53. MX-47h: SPKMIXR Control

Name	Bits	Read/Write	Reset State	Description
gain_bst2_spkmixr	15:14	R/W	0'h	Gain Control for BST2 to SPKMIXR 00'b: 0dB 01'b: -3dB 10'b: -6dB 11'b: -9dB
gain_inr_spkmixr	13:12	R/W	0'h	Gain Control for INR to SPKMIXR 00'b: 0dB 01'b: -3dB 10'b: -6dB 11'b: -9dB
gain_dacr1_spkmixr	11:10	R/W	0'h	Gain Control for DACR1 to SPKMIXR 00'b: 0dB 01'b: -3dB 10'b: -6dB 11'b: -9dB
gain_dacr2_spkmixr	9:8	R/W	0'h	Gain Control for DACR2 to SPKMIXR 00'b: 0dB 01'b: -3dB 10'b: -6dB 11'b: -9dB
Reserved	7:6	R/W	0'h	Reserved
Mu_bst2_spkmixr	5	R/W	1'h	BST2 to SPKMIXR Mute Control 0'b : Un-Mute 1'b: Mute (-∞ dB)
Reserved	4	R/W	1'h	Reserved
Mu_inr_spkmixr	3	R/W	1'h	INR to SPKMIXR Mute Control 0'b : Un-Mute 1'b: Mute (-∞ dB)
Mu_dacr2_spkmixr	2	R/W	1'h	DACR2 to SPKMIXR Mute Control 0'b : Un-Mute 1'b: Mute (-∞ dB)
Mu_dacr1_spkmixr	1	R/W	1'h	DACR1 to SPKMIXR Mute Control 0'b : Un-Mute 1'b: Mute (-∞ dB)
Reserved	0	R	0'h	Reserved

9.38. MX-48h: SPOMIX Control

Default: F807'h

Table 54. MX-48h: SPOMIX Control

Name	Bits	Read/Write	Reset State	Description
Mu_dacl1_spomixl	15	R/W	1'h	DACL1 to SPOMIXL Mute Control 0'b : Un-Mute 1'b: Mute (-∞ dB)
Mu_dacr1_spomixl	14	R/W	1'h	DACR1 to SPOMIXL Mute Control 0'b : Un-Mute 1'b: Mute (-∞ dB)
Mu_spkvoll_spomixl	13	R/W	1'h	SPKVOLL to SPOMIXL Mute Control 0'b : Un-Mute 1'b: Mute (-∞ dB)
Mu_spkvolr_spomixl	12	R/W	1'h	SPKVOLR to SPOMIXL Mute Control 0'b : Un-Mute 1'b: Mute (-∞ dB)
Reserved	11:3	R/W	100'h	Reserved
Mu_dacr1_spomixr	2	R/W	1'h	DACR1 to SPOMIXR Mute Control 0'b : Un-Mute 1'b: Mute (-∞ dB)
Reserved	1	R/W	1'h	Reserved
Mu_spkvolr_spomixr	0	R/W	1'h	SPKVOLR to SPOMIXR Mute Control 0'b : Un-Mute 1'b: Mute (-∞ dB)

9.39. MX-4Ah: Speaker Output Gain Control

Default: 0004'h

Table 55. MX-4Ah: Speaker Output Gain Control

Name	Bits	Read/Write	Reset State	Description
Reserved	15:3	R	0'h	Reserved
Spk_gain_clsd	2:0	R/W	4'h	Speaker Amplifier Output Gain Control 000'b: -6dB 001'b: -4.5dB 010'b: -3dB 011'b: -1.5dB 100'b: 0dB 101'b: 0.82dB 110'b: 1.58dB 111'b: 2.28dB

9.40. MX-4Dh: OUTMIXL Control

Default: 0000'h

Table 56. MX-4Dh: OUTMIXL Control

Name	Bits	Read/Write	Reset State	Description
reserved	15:10	R	0'h	Reserved
gain_bst1_outmixl	9:7	R/W	0'h	Gain Control for BST1 to OUTMIXL 000'b: 0dB 001'b: -3dB 010'b: -6dB 011'b: -9dB 100'b: -12dB 101'b: -15dB 110'b: -18dB
gain_inl_outmixl	6:4	R/W	0'h	Gain Control for INL to OUTMIXL 000'b: 0dB 001'b: -3dB 010'b: -6dB 011'b: -9dB 100'b: -12dB 101'b: -15dB 110'b: -18dB
reserved	3:0	R	0'h	Reserved

9.41. MX-4Eh: OUTMIXL Control

Default: 0000'h

Table 57. MX-4Eh: OUTMIXL Control

Name	Bits	Read/Write	Reset State	Description
reserved	15:13	R	0'h	Reserved
gain_dacl2_outmixl	12:10	R/W	0'h	Gain Control for DACL2 to OUTMIXL 000'b: 0dB 001'b: -3dB 010'b: -6dB 011'b: -9dB 100'b: -12dB 101'b: -15dB 110'b: -18dB
gain_dacl1_outmixl	9:7	R/W	0'h	Gain Control for DACL1 to OUTMIXL 000'b: 0dB 001'b: -3dB 010'b: -6dB 011'b: -9dB 100'b: -12dB 101'b: -15dB 110'b: -18dB
Reserved	6:0	R	0'h	Reserved

9.42. MX-4Fh: OUTMIXL Control

Default: 001F'h

Table 58. MX-4Fh: OUTMIXL Control

Name	Bits	Read/Write	Reset State	Description
Reserved	15:4	R/W	1'h	reserved
Mu_bst1_outmixl	3	R/W	1'h	Mute Control for BST1 to OUTMIXL 0'b: Un-Mute 1'b: Mute (-∞ dB)
Mu_inl_outmixl	2	R/W	1'h	Mute Control for INL to OUTMIXL 0'b: Un-Mute 1'b: Mute (-∞ dB)

Name	Bits	Read/Write	Reset State	Description
Mu_dacl2_outmixl	1	R/W	1'h	Mute Control for DACL2 to OUTMIXL 0'b: Un-Mute 1'b: Mute (-∞ dB)
Mu_dacl1_outmixl	0	R/W	1'h	Mute Control for DACL1 to OUTMIXL 0'b: Un-Mute 1'b: Mute (-∞ dB)

9.43. MX-50h: OUTMIXR Control

Default: 0000'h

Table 59. MX-50h: OUTMIXR Control

Name	Bits	Read/Write	Reset State	Description
reserved	15:13	R	0'h	Reserved
gain_bst2_outmixr	12:10	R/W	0'h	Gain Control for BST2 to OUTMIXR 000'b: 0dB 001'b: -3dB 010'b: -6dB 011'b: -9dB 100'b: -12dB 101'b: -15dB 110'b: -18dB
reserved	9:7	R	0'h	Reserved
gain_inr_outmixr	6:4	R/W	0'h	Gain Control for INR to OUTMIXR 000'b: 0dB 001'b: -3dB 010'b: -6dB 011'b: -9dB 100'b: -12dB 101'b: -15dB 110'b: -18dB
reserved	3:0	R	0'h	Reserved

9.44. MX-51h: OUTMIXR Control

Default: 0000'h

Table 60. MX-51h: OUTMIXR Control

Name	Bits	Read/Write	Reset State	Description
reserved	15:13	R	0'h	Reserved
gain_dacr2_outmixr	12:10	R/W	0'h	Gain Control for DACR2 to OUTMIXR 000'b: 0dB 001'b: -3dB 010'b: -6dB 011'b: -9dB 100'b: -12dB 101'b: -15dB 110'b: -18dB
gain_dacr1_outmixr	9:7	R/W	0'h	Gain Control for DACR1 to OUTMIXR 000'b: 0dB 001'b: -3dB 010'b: -6dB 011'b: -9dB 100'b: -12dB 101'b: -15dB 110'b: -18dB
Reserved	6:0	R	0'h	Reserved

9.45. MX-52h: OUTMIXR Control

Default: 001F'h

Table 61. MX-52h: OUTMIXR Control

Name	Bits	Read/Write	Reset State	Description
reserved	15:4	R/W	1'h	reserved
Mu_bst2_outmixr	3	R/W	1'h	Mute Control for BST2 to OUTMIXR 0'b: Un-Mute 1'b: Mute (-∞ dB)
Mu_inr_outmixr	2	R/W	1'h	Mute Control for INR to OUTMIXR 0'b: Un-Mute 1'b: Mute (-∞ dB)
Mu_dacr2_outmixr	1	R/W	1'h	Mute Control for DACR2 to OUTMIXR 0'b: Un-Mute 1'b: Mute (-∞ dB)
Mu_dacr1_outmixr	0	R/W	1'h	Mute Control for DACR1 to OUTMIXR 0'b: Un-Mute 1'b: Mute (-∞ dB)

9.46. MX-53h: LOUTMIX Control

Default: F000'h

Table 62. MX-53h: LOUTMIX Control

Name	Bits	Read/Write	Reset State	Description
mu_dacl1_lout	15	R/W	1'h	Mute DACL1 to LOUT Mixer 0'b: Un-Mute 1'b: Mute (-∞ dB)
mu_dacr1_lout	14	R/W	1'h	Mute DACR1 to LOUT Mixer 0'b: Un-Mute 1'b: Mute (-∞ dB)
mu_outmixl_lout	13	R/W	1'h	Mute Output Left Volume to LOUT Mixer 0'b: Un-Mute 1'b: Mute (-∞ dB)
mu_outmixr_lout	12	R/W	1'h	Mute Output Right Volume to LOUT Mixer 0'b: Un-Mute 1'b: Mute (-∞ dB)
bst_lout	11	R/W	0'h	Gain Control for ALL path to LOUT Mixer 0'b: 0dB 1'b: -6dB
reserved	10:0	R	0'h	Reserved

9.47. MX-56h: Haptic Generator Control

Default: 0111'h

Table 63. MX-56h: Haptic Generator Control

Name	Bits	Read/Write	Reset State	Description
Act_trigger	15	R	0'h	Actuator Trigger Enable Write "1" to trigger actuator
Act_type	14	R/W	0'h	Actuator Type 0'b: Linear resonant actuator (AC) 1'b: Eccentric Rotating Mass (DC)
Act_mode	13:12	R/W	0'h	Actuator Trigger Type 00'b: Disable 01'b: One shot 10'b: Continuous 11'b: Programmable
Act_freq	11:0	R/W	111'h	Actuator Resonant Frequency 111'h: 100Hz ... 888'h: 800Hz, with 2Hz/Step

9.48. MX-57h: Haptic Generator Control

Default: 0064'h

Table 64. MX-57h: Haptic Generator Control

Name	Bits	Read/Write	Reset State	Description
Act_inv	15	R/W	0'h	Actuator Output Invert Control 0'b: Normal 1'b: Invert
Act_busy	14	R	0'h	Actuator Status (Only for one-shot and programmable mode) 0'b: Available 1'b: Busy
Reserved	13:12	R	0'h	Reserved
Act_duration	11:0	R/W	64'h	Actuator Duration for One-Shot and Programmable Mode 000'h: 0ms 001'h: 0.625ms ... FFF'h: 2559.375ms, with 0.625ms/step

9.49. MX-58h: Haptic Generator Control

Default: EF0E'h

Table 65. MX-58h: Haptic Generator Control

Name	Bits	Read/Write	Reset State	Description
Act_prog_1	15:0	R/W	EF0E'h	Actuator Programmable Sequence 1 (Start of programmable seauence) Seauence starts at MSB (bit-15) Each bit represents a time frame specified by act_duration. "1" means enable signal generator.

9.50. MX-59h: Haptic Generator Control

Default: F0F0'h

Table 66. MX-59h: Haptic Generator Control

Name	Bits	Read/Write	Reset State	Description
Act_prog_2	15:0	R/W	F0F0'h	Actuator Programmable Sequence 2

9.51. MX-5Ah: Haptic Generator Control

Default: EF0E'h

Table 67. MX-5Ah: Haptic Generator Control

Name	Bits	Read/Write	Reset State	Description
Act_prog_3	15:0	R/W	EF0E'h	Actuator Programmable Sequence 3

9.52. MX-5Bh: Haptic Generator Control

Default: F0F0'h

Table 68. MX-5Bh: Haptic Generator Control

Name	Bits	Read/Write	Reset State	Description
Act_prog_4	15:0	R/W	F0F0'h	Actuator Programmable Sequence 4

9.53. MX-5Ch: Haptic Generator Control

Default: EF0E'h

Table 69. MX-5Ch: Haptic Generator Control

Name	Bits	Read/Write	Reset State	Description
Act_prog_5	15:0	R/W	EF0E'h	Actuator Programmable Sequence 5

9.54. MX-5Dh: Haptic Generator Control

Default: F0F0'h

Table 70. MX-5Dh: Haptic Generator Control

Name	Bits	Read/Write	Reset State	Description
Act_prog_6	15:0	R/W	F0F0'h	Actuator Programmable Sequence 6

9.55. MX-5Eh: Haptic Generator Control

Default: F000'h

Table 71. MX-5Eh: Haptic Generator Control

Name	Bits	Read/Write	Reset State	Description
Act_prog_7	15:0	R/W	F000'h	Actuator Programmable Sequence 7

9.56. MX-5Fh: Haptic Generator Control

Default: 0000'h

Table 72. MX-5Fh: Haptic Generator Control

Name	Bits	Read/Write	Reset State	Description
Act_prog_8	15:0	R/W	0'h	Actuator Programmable Sequence 8

9.57. MX-61h: Power Management Control 1

Default: 0300'h

Table 73. MX-61h: Power Management Control 1

Name	Bits	Read/Write	Reset State	Description
En_i2s1	15	R/W	0'h	I2S1 Digital Interface Power Control 0'b: Power Down 1'b: Power On
En_i2s2	14	R/W	0'h	I2S2 Digital Interface Power Control 0'b: Power Down 1'b: Power On
reserved	13	R/W	0'h	Reserved
Pow_dac_l_1	12	R/W	0'h	Analog DACL1 Power Control 0'b: Power Down 1'b: Power On
Pow_dac_r_1	11	R/W	0'h	Analog DACR1 Power Control 0'b: Power Down 1'b: Power On
reserved	10	R	0'h	Reserved
Pow_cls_d_r	9	R/W	1'h	Class-D Right Channel Power Control 1 0'b: Power Down 1'b: Power On

Name	Bits	Read/Write	Reset State	Description
Pow_clsd_l	8	R/W	1'h	Class-D Left Channel Power Control ❶ 0'b: Power Down 1'b: Power On
Pow_dac_l_2	7	R/W	0'h	Analog DACL2 Power Control 0'b: Power Down 1'b: Power On
Pow_dac_r_2	6	R/W	0'h	Analog DACR2 Power Control 0'b: Power Down 1'b: Power On
reserved	5:3	R	0'h	Reserved
Pow_adc_l	2	R/W	0'h	Analog ADCL Power Control 0'b: Power Down 1'b: Power On
Pow_adc_r	1	R/W	0'h	Analog ADCR Power Control 0'b: Power Down 1'b: Power On
Pow_clsd	0	R/W	0'h	Class-D Power Control ❶ 0'b: Power Down 1'b: Power On

❶

Class-D left channel power = pow_clsd & pow_clsd_l

Class-D right channel power = pow_clsd & pow_clsd_r

9.58. MX-62h: Power Management Control 2

Default: 0000'h

Table 74. MX-62h: Power Management Control 2

Name	Bits	Read/Write	Reset State	Description
Pow_adc_stereo_filte r	15	R/W	0'h	Stereo1 ADC Digital Filter Power Control 0'b: Power Down 1'b: Power On
Pow_adc_monol_filte r	14	R/W	0'h	Mono ADC_L Digital Filter Power Control 0'b: Power Down 1'b: Power On
Pow_adc_monor_filte r	13	R/W	0'h	Mono ADC_R Digital Filter Power Control 0'b: Power Down 1'b: Power On
Reserved	12	R	0'h	Reserved
pow_dac_stereo1_filt er	11	R/W	0'h	Power on DAC stereo1 filter 0'b: Power Down 1'b: Power On
pow_dac_monol_filte r	10	R/W	0'h	Power on DAC mono left filter 0'b: Power Down 1'b: Power On
pow_dac_monor_filte r	9	R/W	0'h	Power on DAC mono right filter 0'b: Power Down 1'b: Power On
reserved	8	R	0'h	Reserved

Name	Bits	Read/Write	Reset State	Description
Pow_pdm	7	R/W	0'h	Power on PDM Interface 0'b: Power down 1'b: Power on
reserved	6:0	R	0'h	Reserved

9.59. MX-63h: Power Management Control 3

Default: 00C0'h

Table 75. MX-63h: Power Management Control 3

Name	Bits	Read/Write	Reset State	Description
Pow_vref1	15	R/W	0'h	VREF1 Power Control 0'b: Power Down 1'b: Power On
En_fastb1	14	R/W	0'h	VREF1 Fast Mode Control 0'b: Fast VREF 1'b: Slow VREF, (For good analog performance)
Pow_main_bias	13	R/W	0'h	MBIAS Power Control 0'b: Power Down 1'b: Power On
Pow_lout	12	R/W	0'h	LOUTMIX Power Control 0'b: Power Down 1'b: Power On
Pow_bg_bias	11	R/W	0'h	MBIAS Bandgap Power Control 0'b: Power Down 1'b: Power On
reserved	10:8	R	0'h	Reserved
En_l_hp	7	R/W	1'h	Left Headphone Amp Power Control 0'b: Power Down 1'b: Power On
En_r_hp	6	R/W	1'h	Right Headphone Amp Power Control 0'b: Power Down 1'b: Power On
En_amp_hp	5	R/W	0'h	Improve HP Amp Driving 0'b: Disable 1'b: Enable
Pow_vref2	4	R/W	0'h	VREF2 Power Control 0'b: Power Down 1'b: Power On
En_fastb2	3	R/W	0'h	VREF2 Fast Mode Control 0'b: Fast VREF 1'b: Slow VREF, (For good analog performance)
reserved	2	R	0'h	Reserved
Dvo_ldo1	1:0	R/W	2'h	Selection of the LDO1 output 00'b: 0.9V 01'b: 1.0V 10'b: 1.2V 11'b: 1.4V

9.60. MX-64h: Power Management Control 4

Default: 0000'h

Table 76. MX-64h: Power Management Control 4

Name	Bits	Read/Write	Reset State	Description
Pow_bst1	15	R/W	0'h	MIC BST1 Power Control 0'b: Power Down 1'b: Power On
Pow_bst2	14	R/W	0'h	MIC BST2 Power Control 1 0'b: Power Down 1'b: Power On
reserved	13:12	R/W	0'h	reserved
Pow_micbias1	11	R/W	0'h	MICBIAS1 Power Control 0'b: Power Down 1'b: Power On
Pow_micbias2	10	R/W	0'h	MICBIAS2 Power Control 0'b: Power Down 1'b: Power On
Pow_pll	9	R/W	0'h	PLL Power Control 0'b: Power Down 1'b: Power On
reserved	8:6	R	0'h	Reserved
Pow_bst2_2	5	R/W	0'h	MIC BST2 Power Control 2 0'b: Power Down 1'b: Power On
reserved	4:3	R	0'h	Reserved
Pow_jd1	2	R/W	0'h	JD1 Power Control 0'b: Power Down 1'b: Power On
Pow_jd2	1	R/W	0'h	JD2 Power Control 0'b: Power Down 1'b: Power On
reserved	0	R	0'h	Reserved

9.61. MX-65h: Power Management Control 5

Default: 0000'h

Table 77. MX-65h: Power Management Control 5

Name	Bits	Read/Write	Reset State	Description
Pow_outmixl	15	R/W	0'h	OUTMIXL Power Control 0'b: Power Down 1'b: Power On
Pow_outmixr	14	R/W	0'h	OUTMIXR Power Control 0'b: Power Down 1'b: Power On
Pow_spkmixl	13	R/W	0'h	SPKMIXL Power Control 0'b: Power Down 1'b: Power On
Pow_spkmixr	12	R/W	0'h	SPKMIXR Power Control 0'b: Power Down 1'b: Power On
Pow_recmixl	11	R/W	0'h	RECMIXL Power Control 0'b: Power Down 1'b: Power On
Pow_recmixr	10	R/W	0'h	RECMIXR Power Control 0'b: Power Down 1'b: Power On
reserved	9:8	R	0'h	Reserved
Pow_hpmixl	7	R/W	0'h	HPMIXL Power Control 0'b: Power Down 1'b: Power On
Pow_hpmixr	6	R/W	0'h	HPMIXR Power Control 0'b: Power Down 1'b: Power On
reserved	5:2	R	0'h	Reserved
Pow_ldo2	1	R/W	0'h	LDO2 Power Control 0'b: Power off 1'b: Power on
reserved	0	R	0'h	Reserved

9.62. MX-66h: Power Management Control 6

Default: 0000'h

Table 78. MX-66h: Power Management Control 6

Name	Bits	Read/Write	Reset State	Description
Pow_spo_voll	15	R/W	0'h	SPKVOLL Power Control 0'b: Power Down 1'b: Power On
Pow_spo_volr	14	R/W	0'h	SPKVOLR Power Control 0'b: Power Down 1'b: Power On
Pow_o_voll	13	R/W	0'h	OUTVOLL Power Control 0'b: Power Down 1'b: Power On
Pow_o_volr	12	R/W	0'h	OUTVOLR Power Control 0'b: Power Down 1'b: Power On
Pow_hpovoll	11	R/W	0'h	HPVOLL Power Control 0'b: Power Down 1'b: Power On
Pow_hpovolr	10	R/W	0'h	HPVOLR Power Control 0'b: Power Down 1'b: Power On
Pow_inlvol	9	R/W	0'h	INLVOL Power Control 0'b: Power Down 1'b: Power On
Pow_inrvol	8	R/W	0'h	INRVOL Power Control 0'b: Power Down 1'b: Power On
reserved	7:6	R	0'h	Reserved
Pow_mic_in_det	5	R/W	0'h	MIC_IN_DET Power Control 0'b: Power Down 1'b: Power On
reserved	4:0	R	0'h	Reserved

9.63. MX-6Ah: Private Register Index

Default: 0000'h

Table 79. MX-6Ah: Private Register Index

Name	Bits	Read/Write	Reset State	Description
reserved	15:8	R	0'h	reserved
Pr_index	7:0	R/W	0'h	PR Register Index

9.64. MX-6Ch: Private Register Data

Default: 0000'h

Table 80. MX-6Ch: Private Register Data

Name	Bits	Read/Write	Reset State	Description
Pr_data	15:0	R/W	0'h	PR Register Data

9.65. MX-70h: I2S1 Digital Interface Control

Default: 8000'h

Table 81. MX-70h: I2S1 Digital Interface Control

Name	Bits	Read/Write	Reset State	Description
Sel_i2s1_ms	15	R/W	1'h	I2S1 Digital Interface Mode Control 0'b: Master Mode 1'b: Slave Mode
reserved	14:12	R	0'h	Reserved
en_i2s1_out_comp	11:10	R/W	0'h	I2S1 Output Data Compress (For ADCDAT1 Output) 00'b: OFF 01'b: μ law 10'b: A law 11'b: Reserved
en_i2s1_in_comp	9:8	R/W	0'h	I2S1 Input Data Compress (For DACDAT1 Input) 00'b: OFF 01'b: μ law 10'b: A law 11'b: Reserved
Inv_i2s1_bclk	7	R/W	0'h	I2S1 BCLK Polarity Control 0'b: Normal 1'b: Invert
reserved	6:4	R	0'h	Reserved
sel_i2s1_len	3:2	R/W	0'h	I2S1 Data Length Selection 00'b: 16 bits 01'b: 20 bits 10'b: 24 bits 11'b: 8 bits
sel_i2s1_format	1:0	R/W	0'h	I2S1 PCM Data Format Selection 00'b: I ² S format 01'b: Left justified 10'b: PCM Mode A (LRCK One Plus at Master Mode) 11'b: PCM Mode B (LRCK One Plus at Master Mode)

9.66. MX-71h: I2S2 Digital Interface Control

Default: 8000'h

Table 82. MX-71h: I2S2 Digital Interface Control

Name	Bits	Read/Write	Reset State	Description
Sel_i2s2_ms	15	R/W	1'h	I2S2 Digital Interface Mode Control 0'b: Master Mode 1'b: Slave Mode
reserved	14:12	R	0'h	Reserved
en_i2s2_out_comp	11:10	R/W	0'h	I2S2 Output Data Compress (For ADCDAT2 Output) 00'b: OFF 01'b: μ law 10'b: A law 11'b: Reserved
en_i2s2_in_comp	9:8	R/W	0'h	I2S2 Input Data Compress (For DACDAT2 Input) 00'b: OFF 01'b: μ law 10'b: A law 11'b: Reserved
inv_i2s2_bclk	7	R/W	0'h	I2S2 BCLK Polarity Control 0'b: Normal 1'b: Invert
reserved	6:4	R	0'h	Reserved
sel_i2s2_len	3:2	R/W	0'h	I2S2 Data Length Selection 00'b: 16 bits 01'b: 20 bits 10'b: 24 bits 11'b: 8bits
sel_i2s2_format	1:0	R/W	0'h	I2S2 PCM Data Format Selection 00'b: I ² S format 01'b: Left justified 10'b: PCM Mode A (LRCK One Plus at Master Mode) 11'b: PCM Mode B (LRCK One Plus at Master Mode)

9.67. MX-73h: ADC/DAC Clock Control

Default: 1114'h

Table 83. MX-73h: ADC/DAC Clock Control

Name	Bits	Read/Write	Reset State	Description
reserved	15	R	0'h	Reserved
sel_i2s_pre_div1	14:12	R/W	1'h	I2S Clock Pre-Divider 1 000'b: ÷ 1 001'b: ÷ 2 010'b: ÷ 3 011'b: ÷ 4 100'b: ÷ 6 101'b: ÷ 8 110'b: ÷ 12 111'b: ÷ 16
sel_i2s_bclk_ms2	11	R/W	0'h	I2S2 Master Mode Clock Relative of BCLK and LRCK 0'b: 16Bits (32FS) 1'b: 32Bits (64FS)
sel_i2s_pre_div2	10:8	R/W	1'h	I2S Pre-Divider 2 000'b: ÷ 1 001'b: ÷ 2 010'b: ÷ 3 011'b: ÷ 4 100'b: ÷ 6 101'b: ÷ 8 110'b: ÷ 12 111'b: ÷ 16
reserved	7:4	R/W	1'h	Reserved
sel_dac_osr	3:2	R/W	1'h	Stereo DAC Over Sample Rate Select 00'b: 128Fs 01'b: 64Fs 10'b: 32Fs 11'b: Reserved
sel_adc_osr	1:0	R/W	0'h	Stereo ADC Over Sample Rate Select 00'b: 128Fs 01'b: 64Fs 10'b: 32Fs 11'b: Reserved

9.68. MX-74h: ADC/DAC HPF Control

Default: 3E00'h

Table 84. MX-74h: ADC/DAC HPF Control

Name	Bits	Read/Write	Reset State	Description
reserved	15:12	R	3'h	Reserved
Dehpf_en	11	R/W	1'h	Enable Stereo/Mono DAC High Pass Filter 0'b: Disable 1'b: Enable
Adhpf_en	10	R/W	1'h	Enable Stereo1/2 ADC High Pass Filter 0'b: Disable 1'b: Enable
Mono_adhpf_en	9	R/W	1'h	Enable Mono ADC High Pass Filter 0'b: Disable 1'b: Enable
Reserved	8:0	R	0'h	Reserved

9.69. MX-75h: Digital Microphone Control 1

Default: 1405'h

Table 85. MX-75h: Digital Microphone Control 1

Name	Bits	Read/Write	Reset State	Description
en_dmic1	15	R/W	0'h	Enable DMIC1 Interface 0'b: Disable 1'b: Enable (Output DMIC clock)
en_dmic2	14	R/W	0'h	Enable DMIC2 Interface 0'b: Disable 1'b: Enable (Output DMIC clock)
sel_dmic_l_edge_stereo1	13	R/W	0'h	Stereo1 ADC Filter DMIC Left Channel Source Control (Synchronous Mode) 0'b: Latch from falling edge 1'b: Latch from rising edge
sel_dmic_r_edge_stereo1	12	R/W	1'h	Stereo1 ADC Filter DMIC Right Channel Source Control (Synchronous Mode) 0'b: Latch from falling edge 1'b: Latch from rising edge
Dmic2_data_pin_share	11:10	R/W	1'h	Select the Pin share of DMIC2_DATA 00'b: GPIO6 01'b: Reserved 10'b: Reserved 11'b: Reserved
Reserved	9:8	R	0'h	Reserved

Name	Bits	Read/Write	Reset State	Description
sel_dmic_clk	7:5	R/W	0'h	DMIC Clock Rate Control 000'b: 256*fs/2 001'b: 256*fs/3 010'b: 256*fs/4 011'b: 256*fs/6 100'b: 256*fs/8 101'b: 256*fs/12
Reserved	4	R	0'h	Reserved
sel_dmic_l_edge_mono	3	R/W	0'h	Mono ADC Filter DMIC Left Channel Source Control (Synchronous Mode) 0'b: Latch from falling edge 1'b: Latch from rising edge
sel_dmic_r_edge_mono	2	R/W	1'h	Mono ADC Filter DMIC Right Channel Source Control (Synchronous Mode) 0'b: Latch from falling edge 1'b: Latch from rising edge
dmic1_data_pin_share	1:0	R/W	1'h	Select the Pin share of DMIC1_DATA 00'b: GPIO5 01'b: IN2N 10'b: Reserved 11'b: Reserved

9.70. MX-76h: Digital Microphone Control 2

Default: 0005'h

Table 86. MX-76h: Digital Microphone Control 2

Name	Bits	Read/Write	Reset State	Description
Reserved	15:4	R	0'h	Reserved
sel_dmic2_lpf_l_edge	3	R/W	0'h	DMIC2 Data Left Channel Source Control (Asynchronous Mode) 0'b: Latch from falling edge 1'b: Latch from rising edge
sel_dmic2_lpf_r_edge	2	R/W	1'h	DMIC2 Data Right Channel Source Control (Asynchronous Mode) 0'b: Latch from falling edge 1'b: Latch from rising edge
sel_dmic1_lpf_l_edge	1	R/W	0'h	DMIC1 Data Left Channel Source Control (Asynchronous Mode) 0'b: Latch from falling edge 1'b: Latch from rising edge
sel_dmic1_lpf_r_edge	0	R/W	1'h	DMIC1 Data Right Channel Source Control (Asynchronous Mode) 0'b: Latch from falling edge 1'b: Latch from rising edge

9.71. MX-77h: TDM Interface Control 1

Default: 0C00'h

Table 87. MX-77h: TDM Interface Control 1

Name	Bits	Read/Write	Reset State	Description
reserved	15	R/W	0'h	Reserved
mode_sel	14	R/W	0'h	I2S / TDM Mode Control 0'b: Normal I2S Mode 1'b: TDM Mode
Tdmslot_sel	13:12	R/W	0'h	TDM Channel Number Select 00'b: 2ch 01'b: 4ch 10'b: 6ch 11'b: 8ch
Channel_length	11:10	R/W	3'h	TDM Channel Length 00'b: 16bit (For Slave Mode and Master Mode) 01'b: 20bit (For Slave Mode) 10'b: 24bit (For Slave Mode) 11'b: 32bit (For Slave Mode and Master Mode)
rx_adc_data_sel	9:8	R/W	0'h	ADC Data to ADCDAT Data Location 00'b: IF_ADC1/IF_ADC2/Reserved 01'b: IF_ADC2/IF_ADC1/Reserved 10'b: Reserved/IF_ADC1/IF_ADC2 11'b: Reserved/IF_ADC2/IF_ADC1
sel_i2s_rx_ch2	7:6	R/W	0'h	Data Swap for Slot0/1 in ADCDAT1 00'b: L/R 01'b: R/L 10'b: L/L 11'b: R/R
sel_i2s_rx_ch4	5:4	R/W	0'h	Data Swap for Slot2/3 in ADCDAT1 00'b: L/R 01'b: R/L 10'b: L/L 11'b: R/R
sel_i2s_rx_ch6	3:2	R/W	0'h	Data Swap for Slot4/5 in ADCDAT1 00'b: L/R 01'b: R/L 10'b: L/L 11'b: R/R
sel_i2s_rx_ch8	1:0	R/W	0'h	Data Swap for Slot6/7 in ADCDAT1 00'b: L/R 01'b: R/L 10'b: L/L 11'b: R/R

9.72. MX-78h: TDM Interface Control 2

Default: 0000'h

Table 88. MX-78h: TDM Interface Control 2

Name	Bits	Read/Write	Reset State	Description
sel_i2s_lrck_polarity	15	R/W	0'h	TDM Interface LRCK Polarity Inverter 0'b: Normal 1'b: Invert
reserved	14:12	R	0'h	Reserved
lrck_pulse_sel	11	R/W	0'h	LRCK Pulse Width Select (Master Mode Only) 0'b: One BCLK width 1'b: One channel slot width
reserved	10:8	R/W	0'h	Reserved
mute_tdm2_outl	7	R/W	0'h	IF1_ADC1 Left Data Mute/Un-mute Control 0'b : Un-Mute 1'b : Mute
mute_tdm2_outr	6	R/W	0'h	IF1_ADC1 Right Data Mute/Un-mute Control 0'b : Un-Mute 1'b : Mute
mute_tdm4_outl	5	R/W	0'h	IF1_ADC2 Left Data Mute/Un-mute Control 0'b : Un-Mute 1'b : Mute
mute_tdm4_outr	4	R/W	0'h	IF1_ADC2 Right Data Mute/Un-mute Control 0'b : Un-Mute 1'b : Mute
mute_tdm6_outl	3	R/W	0'h	IF1_ADC3 Left Data Mute/Un-mute Control 0'b : Un-Mute 1'b : Mute
mute_tdm6_outr	2	R/W	0'h	IF1_ADC3 Right Data Mute/Un-mute Control 0'b : Un-Mute 1'b : Mute
mute_tdm8_outl	1	R/W	0'h	IF1_ADC4 Left Data Mute/Un-mute Control 0'b : Un-Mute 1'b : Mute
mute_tdm8_outr	0	R/W	0'h	IF1_ADC4 Right Data Mute/Un-mute Control 0'b : Un-Mute 1'b : Mute

9.73. MX-79h: TDM Interface Control 3

Default: 0123'h

Table 89. MX-79h: TDM Interface Control 3

Name	Bits	Read/Write	Reset State	Description
Reserved	15	R	0'h	Reserved
sel_i2s_tx_l_ch2	14:12	R/W	0'h	IF1_DAC1_L Data Selection 000'b: Slot0 001'b: Slot1 010'b: Slot2 011'b: Slot3 100'b: Slot4 101'b: Slot5 110'b: Slot6 111'b: Slot7
Reserved	11	R	0'h	Reserved
sel_i2s_tx_r_ch2	10:8	R/W	1'h	IF1_DAC1_R Data Selection 000'b: Slot0 001'b: Slot1 010'b: Slot2 011'b: Slot3 100'b: Slot4 101'b: Slot5 110'b: Slot6 111'b: Slot7
Reserved	7	R	0'h	Reserved
sel_i2s_tx_l_ch4	6:4	R/W	2'h	IF1_DAC2_L Data Selection 000'b: Slot0 001'b: Slot1 010'b: Slot2 011'b: Slot3 100'b: Slot4 101'b: Slot5 110'b: Slot6 111'b: Slot7
Reserved	3	R	0'h	Reserved
sel_i2s_tx_r_ch4	2:0	R/W	3'h	IF1_DAC2_R Data Selection 000'b: Slot0 001'b: Slot1 010'b: Slot2 011'b: Slot3 100'b: Slot4 101'b: Slot5 110'b: Slot6 111'b: Slot7

9.74. MX-80h: Global Clock Control

Default: 0000'h

Table 90. MX-80h: Global Clock Control

Name	Bits	Read/Write	Reset State	Description
sel_sysclk1	15:14	R/W	0'h	System Clock Source MUX Control 00'b: MCLK 01'b: PLL 10'b: Reserved 11'b: Reserved
sel_pll_sour	13:11	R/W	0'h	PLL Source Selection 000'b: From MCLK 001'b: From BCLK1 010'b: From BCLK2 011'b: Reserved 100'b: Internal clock Others: Reserved
reserved	10:4	R	0'h	Reserved
sel_pll_pre_div	3	R/W	0'h	PLL Pre-Divider 0'b: ÷ 1 1'b: ÷ 2
Sys_div_stereo_da_filter	2:0	R/W	0'h	Select System Clock Divider for Stereo DAC Filter 000'b: /1 001'b: /2 010'b: /3 011'b: /4 100'b: /6 101'b: /8 110'b: /12 111'b: /16

9.75. MX-81h: PLL Control 1

Default: 0000'h

Table 91. MX-81h: PLL Control 1

Name	Bits	Read/Write	Reset State	Description
PLL_n_code	15:7	R/W	0'h	PLL N[8:0] Code 00000000'b: Div 2 00000001'b: Div 3 ... 11111111'b: Div 513
Reserved	6:5	R	0'h	Reserved
PLL_k_code	4:0	R/W	0'h	PLL K[4:0] Code 00000'b: Div 2 00001'b: Div 3 ... 11111'b: Div 33

9.76. MX-82h: PLL Control 2

Default: 0000'h

Table 92. MX-82h: PLL Control 2

Name	Bits	Read/Write	Reset State	Description
PLL_m_code	15:12	R/W	0'h	PLL M[3:0] Code 0000'b: Div 2 0001'b: Div 3 ... 1111'b: Div 17
PLL_m_bypass	11	R/W	0'h	Bypass PLL M Code 0'b : No bypass 1'b : Bypass
Reserved	10:0	R	0'h	Reserved

9.77. MX-83h: ASRC Control 1

Default: 0000'h

Table 93. MX-83h: ASRC Control 1

Name	Bits	Read/Write	Reset State	Description
Reserved	15:13	R	0'h	Reserved
En_i2s2_asrc	12	R/W	0'h	Enable I2S2 ASRC Function 0'b: Disable 1'b: Enable
En_i2s1_asrc	11	R/W	0'h	Enable I2S1 ASRC Function 0'b: Disable 1'b: Enable
Sel_stereo_dac_mode	10	R/W	0'h	Enable DAC ASRC for Stereo DAC 0'b : Disable 1'b : Enable
Sel_mono_dac_l_mode	9	R/W	0'h	Enable DAC ASRC for mono left path 0'b : Disable 1'b : Enable
Sel_mono_dac_r_mode	8	R/W	0'h	Enable DAC ASRC for mono right path 0'b : Disable 1'b : Enable
en_dmic_asrc_stereo1	7	R/W	0'h	Enable DMIC ASRC for stereo1 path 0'b : Disable 1'b : Enable
reserved	6	R	0'h	Reserved
en_dmic_asrc_monol	5	R/W	0'h	Enable DMIC ASRC for mono left path 0'b : Disable 1'b : Enable

Name	Bits	Read/Write	Reset State	Description
en_dmic_asrc_monor	4	R/W	0'h	Enable DMIC ASRC for mono right path 0'b : Disable 1'b : Enable
en_adc_asrc_stereo1	3	R/W	0'h	Enable ADC ASRC for stereo1 path 0'b : Disable 1'b : Enable
reserved	2	R	0'h	Reserved
en_adc_asrc_monol	1	R/W	0'h	Enable ADC ASRC for mono left path 0'b : Disable 1'b : Enable
en_adc_asrc_monor	0	R/W	0'h	Enable ADC ASRC for mono right path 0'b : Disable 1'b : Enable

9.78. MX-84h: ASRC Control 2

Default: 0000'h

Table 94. MX-84h: ASRC Control 2

Name	Bits	Read/Write	Reset State	Description
sel_da_filter_stereo_asrc	15:12	R/W	0'h	Select the ASRC Clock Source for DA Stereo Filter 0000'b : CLK_sys 0001'b : clk_i2s1_asrc 0010'b : clk_i2s2_asrc 0011'b : Reserved 0100'b : Reserved 0101'b : clk_sys2 Others: Reserved
sel_da_filter_monol_asrc	11:8	R/W	0'h	Select the ASRC Clock Source for DA Mono Left Filter 0000'b: clk_sysy_div_out 0001'b: clk_i2s1_asrc 0010'b: clk_i2s2_asrc 0011'b: Reserved 0100'b: Reserved 0101'b: clk_sys2 Others: Reserved
sel_da_filter_monor_asrc	7:4	R/W	0'h	Select the ASRC Clock Source for DA Mono Right Filter 0000'b: clk_sysy_div_out 0001'b: clk_i2s1_asrc 0010'b: clk_i2s2_asrc 0011'b: Reserved 0100'b: Reserved 0101'b: clk_sys2 Others: Reserved

Name	Bits	Read/Write	Reset State	Description
sel_ad_filter_stereo1_asrc	3:0	R/W	0'h	Select the ASRC Clock Source for AD Stereo1 Filter 0000'b: clk_sysy_div_out 0001'b: clk_i2s1_asrc 0010'b: clk_i2s2_asrc 0011'b: Reserved 0100'b: Reserved 0101'b: clk_sys2 Others: Reserved

9.79. MX-85h: ASRC Control 3

Default: 0000'h

Table 95. MX-85h: ASRC Control 3

Name	Bits	Read/Write	Reset State	Description
reserved	15:8	R	0'h	Reserved
sel_ad_filter_monol_asrc	7:4	R/W	0'h	Select the ASRC Clock Source for AD Mono Left Filter 0000'b: clk_sysy_div_out 0001'b: clk_i2s1_asrc 0010'b: clk_i2s2_asrc 0011'b: Reserved 0100'b: Reserved 0101'b: clk_sys2 Others: Reserved
sel_ad_filter_monor_asrc	3:0	R/W	0'h	Select the ASRC Clock Source for AD Mono Right Filter 0000'b: clk_sysy_div_out 0001'b: clk_i2s1_asrc 0010'b: clk_i2s2_asrc 0011'b: Reserved 0100'b: Reserved 0101'b: clk_sys2 Others: Reserved

9.80. MX-8Ah: ASRC Control 4

Default: 0000'h

Table 96. MX-8Ah: ASRC Control 4

Name	Bits	Read/Write	Reset State	Description
i2s1_asrc_prediv	15:14	R/W	0'h	Set the I2S1 Clock Division for ASRC Mode 00'b: div1 01'b: div2 10'b: div3 11'b: reserved
sel_i2s1_asrc	13:12	R/W	0'h	Select the ASRC source of ASRC 00'b: ASRC1 01'b: ASRC2 10'b: Reserved 11'b: Reserved
i2s2_asrc_prediv	11:10	R/W	0'h	Set the I2S2 Clock Division for ASRC Mode 00'b: div1 01'b: div2 10'b: div3 11'b: Reserved
sel_i2s2_asrc	9:8	R/W	0'h	Select the ASRC Source of I2S2 00'b: ASRC1 01'b: ASRC2 10'b: Reserved 11'b: Reserved
reserved	7:0	R/W	0'h	Reserved

9.81. MX-8Eh: HP Amp Control 1

Default: 0004'h

Table 97. MX-8Eh: HP Amp Control 1

Name	Bits	Read/Write	Reset State	Description
Smttrig_hp	15	R/W	0'h	Enable Softgen Trigger for Soft Mute Depop 0'b: Disable 1'b: Enable
reserved	14:10	R/W	0'h	Reserved
En_smt_l_hp	9	R/W	0'h	Enable HP_L Mute/Un-Mute Depop 0'b: Disbale 1'b: Enable
En_smt_r_hp	8	R/W	0'h	Enable HP_R Mute/Un-Mute Depop 0'b: Disbale 1'b: Enable
Pdn_hp	7	R/W	0'h	Capless Depop Power Down Control 0'b: Disbale 1'b: Enable
Softgen_rstn	6	R/W	0'h	Reset Softgen to Initialize SOFTP=1 0'b: Disbale 1'b: Reset

Name	Bits	Read/Write	Reset State	Description
Softgen_rstp	5	R/W	0'h	Reset Softgen to Initialize SOFTP=0 0'b: Disbale 1'b: Reset
En_out_hp	4	R/W	0'h	Enable Headphone Output 0'b: Disable 1'b: Enable
Pow_pump_hp	3	R/W	0'h	Charge Pump Power Control 0'b: Power Down 1'b: Power On
En_softgen_hp	2	R/W	1'h	Power On Soft Generator 0'b: Power down 1'b: Power on
En_dp_hp	1	R/W	0'h	Enable Depop Mode for HPO 0'b: Disable 1'b: Enable
Pow_capless	0	R/W	0'h	HP Amp All Power On Control 0'b: Power Down 1'b: Power On

9.82. MX-8Fh: HP Amp Control 2

Default: 1100'h

Table 98. MX-8Fh: HP Amp Control 2

Name	Bits	Read/Write	Reset State	Description
reserved	15:14	R	0'h	Reserved
Depop_mode_hp	13	R/W	0'h	Select HP Depop Mode 0'b: Depop mode 1 1'b: Depop mode 2
reserved	12:7	R/W	22'h	Reserved
En_depop_mode1	6	R/W	0'h	HP Depop Mode 1 Control 0'b: Disbale 1'b: Enable
reserved	5:0	R/W	0'h	Reserved

9.83. MX-93h: MICBIAS Control

Default: 0000'h

Table 99. MX-93h: MICBIAS Control

Name	Bits	Read/Write	Reset State	Description
Sel_micbias1	15	R/W	0'h	MICBIAS1 Output Voltage Control 0'b: 2.7V 1'b: 1.8V
Sel_micbias2	14	R/W	0'h	MICBIAS2 Output Voltage Control 0'b: 2.7V 1'b: 1.8V

Name	Bits	Read/Write	Reset State	Description
reserved	13:12	R/W	0'h	Reserved
Pow_mic1_ovcd	11	R/W	0'h	MICBIAS1 Short Current Detector Control 0'b: Disable 1'b: Enable
Mic1_ovcd_th_sel	10:9	R/W	0'h	MICBIAS1 Short Current Detector Threshold 00'b: 640uA 01'b: 1280uA 1x'b: 1920uA Note: tolerance is 200uA
Pow_mic2_ovcd	8	R/W	0'h	MICBIAS2 Short Current Detector Control 0'b: Disable 1'b: Enable
Mic2_ovcd_th_sel	7:6	R/W	0'h	MICBIAS2 Short Current Detector Threshold 00'b: 640uA 01'b: 1280uA 1x'b: 1920uA Note: tolerance is 200uA
Ckn_micbias	5	R/W	0'h	MICBIAS Clock Power 0'b: Disable 1'b: Enable
Pow_clk_int	4	R/W	0'h	Internal Clock Power 0'b: Disable 1'b: Enable
Sel_irq_debounce	3	R/W	0'h	Select IRQ De-bounce Clock 0'b: MCLK 1'b: Internal clock
reserved	2:0	R	0'h	reserved

9.84. MX-94h: JD1 Control

Default: 0000'h

Table 100. MX-94h: JD1 Control

Name	Bits	Read/Write	Reset State	Description
reserved	15:2	R/W	0'h	Reserved
Sel_mode_jd1	1:0	R/W	0'h	JD1 Mode Control 00'b: Mode-0, two port jack detection 01'b: Mode-1, one port jack detection Others: Reserved

9.85. MX-A0h: Class-D Amp Control

Default: A0A8'h

Table 101. MX-A0h: Class-D Amp Control

Name	Bits	Read/Write	Reset State	Description
Fbgain_clsd	15:12	R/W	0'h	Class-D Amp Ratio Gain Control 0000'b: 1.66x 0001'b: 1.83x 0010'b: 1.94x 0011'b: 2x 0100'b: 2.11x 0101'b: 2.22x 0110'b: 2.33x 0111'b: 2.44x 1000'b: 2.55x 1001'b: 2.66x 1010'b: 2.77x Others: Reserved
reserved	11:10	R/W	0'h	Reserved
En_spk_auto_ratio	9	R/W	0'h	Enable SPKVDD Detection 0'b: Disable 1'b: Enable
En_spk_auto_gain	8	R/W	0'h	Enable Class-D Amp Auto Ratio Gain 0'b: Disable 1'b: Enable
reserved	7	R/W	1'h	Reserved
Autopd_clsd	6	R/W	0'h	Class-D Auto Power Down when Over-Current 0'b: Disable 1'b: Enable
Reserved	5:0	R/W	28'h	Reserved

9.86. MX-AEh: ADC Path EQ Control 1

Default: 6000'h

Table 102. MX-AEh: ADC Path EQ Control 1

Name	Bits	Read/Write	Reset State	Description
Reserved	15	R	0'h	Reserved
ad_eq_param_update	14	R/W	1'h	ADC Path EQ Parameter Update Control 0'b: Busy (Waiting for cross) 1'b: Stand-by Write "1" to update parameter
Reserved	13:6	R/W	80'h	Reserved

Name	Bits	Read/Write	Reset State	Description
Ad_eq_hpf1_status	5	R	0'h	ADC Path EQ High Pass Filter (HPF1) Status. 0'b: Normal 1'b: Overflow. This bit is set if overflow had ever occurred. Write 1 to clear it.
Ad_eq_bpf4_status	4	R	0'h	ADC Path EQ Band-4 (BP4) Status. 0'b: Normal 1'b: Overflow. This bit is set if overflow had ever occurred. Write 1 to clear it.
Ad_eq_bpf3_status	3	R	0'h	ADC Path EQ Band-3 (BP3) Status. 0'b: Normal 1'b: Overflow. This bit is set if overflow had ever occurred. Write 1 to clear it.
Ad_eq_bpf2_status	2	R	0'h	ADC Path EQ Band-2 (BP2) Status. 0'b: Normal 1'b: Overflow. This bit is set if overflow had ever occurred. Write 1 to clear it.
Ad_eq_bpf1_status	1	R	0'h	ADC Path EQ Band-1 (BP1) Status. 0'b: Normal 1'b: Overflow. This bit is set if overflow had ever occurred. Write 1 to clear it.
Ad_eq_lpf_status	0	R	0'h	ADC Path EQ Low Pass Filter (LPF) Status. 0'b: Normal 1'b: Overflow. This bit is set if overflow had ever occurred. Write 1 to clear it.

9.87. MX-AFh: ADC Path EQ Control 2

Default: 0000'h

Table 103. MX-AFh: ADC Path EQ Control 2

Name	Bits	Read/Write	Reset State	Description
reserved	15:9	R	0'h	Reserved
ad_eq_lpf_tpy	8	R/W	0'h	ADC Path 1 st EQ Low Pass Filter Mode Control (LPF) 0'b: Low frequency shelving filter 1'b: 1 st order Butterworth LPF (-20dB per decade)
ad_eq_hpf1_tpy	7	R/W	0'h	ADC Path 1 st EQ High Pass Filter1 Mode Control (HPF1) 0'b: High frequency shelving filter 1'b: 1 st order Butterworth HPF (-20dB per decade)
Reserved	6	R	0'h	Reserved
ad_eq_hpf1_en	5	R/W	0'h	ADC Path EQ 1 st High Pass Filter (HPF1) Control. 0'b: Disabled (bypass) and reset 1'b: Enabled

Name	Bits	Read/Write	Reset State	Description
ad_eq_bpf4_en	4	R/W	0'h	ADC Path 2 nd EQ Band-4 (BP4) shelving Filter Control. 0'b: Disabled and reset 1'b: Enabled.
Ad_eq_bpf3_en	3	R/W	0'h	ADC Path 2 nd EQ Band-3 (BP3) shelving Filter Control. 0'b: Disabled and reset 1'b: Enabled.
Ad_eq_bpf2_en	2	R/W	0'h	ADC Path 2 nd EQ Band-2 (BP2) shelving Filter Control. 0'b: Disabled and reset 1'b: Enabled.
Ad_eq_bpf1_en	1	R/W	0'h	ADC Path 2 nd EQ Band-1 (BP1) shelving Filter Control. 0'b: Disabled and reset 1'b: Enabled.
Ad_eq_lpf_en	0	R/W	0'h	ADC Path 1 st EQ Low Pass Filter (LPF) Filter Control. 0'b: Disabled and reset 1'b: Enabled.

9.88. MX-B0h: DAC Path EQ Control 1

Default: 6000'h

Table 104. MX-B0h: DAC Path EQ Control 1

Name	Bits	Read/Write	Reset State	Description
reserved	15	R	0'h	Reserved
Da_eq_param_update	14	R/W	1'h	DAC Path EQ parameter update control 0'b: Busy (Waiting for cross) 1'b: Stand-by Write "1" to update parameter
reserved	13:8	R/W	20'h	Reserved
Da_eq_lpf1_status	7	R	0'h	DAC Path EQ Low Pass Filter (LPF2) Status. 0'b: Normal 1'b: Overflow. This bit is set if overflow had ever occurred. Write 1 to clear it.
Da_eq_hpf2_status	6	R	0'h	DAC Path EQ High Pass Filter (HPF2) Status. 0'b: Normal 1'b: Overflow. This bit is set if overflow had ever occurred. Write 1 to clear it.
Da_eq_hpf1_status	5	R	0'h	DAC Path EQ High Pass Filter (HPF1) Status. 0'b: Normal 1'b: Overflow. This bit is set if overflow had ever occurred. Write 1 to clear it.
Da_eq_bpf4_status	4	R	0'h	DAC Path EQ Band-4 (BP4) Status. 0'b: Normal 1'b: Overflow. This bit is set if overflow had ever occurred. Write 1 to clear it.

Name	Bits	Read/Write	Reset State	Description
Da_eq_bpf3_status	3	R	0'h	DAC Path EQ Band-3 (BP3) Status. 0'b: Normal 1'b: Overflow. This bit is set if overflow had ever occurred. Write 1 to clear it.
Da_eq_bpf2_status	2	R	0'h	DAC Path EQ Band-2 (BP2) Status. 0'b: Normal 1'b: Overflow. This bit is set if overflow had ever occurred. Write 1 to clear it.
Eq_biquad_wclr	1	R	0'h	DAC Path EQ Band-1 (Biquad Type) Status. 0'b: Normal 1'b: Overflow. This bit is set if overflow had ever occurred. Write 1 to clear it.
Reserved	0	R	0'h	Reserved

9.89. MX-B1h: EQ Control 2

Default: 0000'h

Table 105. MX-B1h: EQ Control 2

Name	Bits	Read/Write	Reset State	Description
reserved	15:14	R	0'h	Reserved
Da_eq_lpf1_tpy_r	13	R/W	0'h	DAC Path Right Channel 1 st EQ Low Pass Filter Mode Control (LPF2) 0'b: Low frequency shelving filter 1'b: 1 st order Butterworth LPF (-20dB per decade)
Da_eq_lpf1_tpy_l	12	R/W	0'h	DAC Path Left Channel 1 st EQ Low Pass Filter Mode Control (LPF2) 0'b: Low frequency shelving filter 1'b: 1 st order Butterworth LPF (-20dB per decade)
Reserved	11:10	R	0'h	Reserved
Da_eq_hpf1_tpy_r	9	R/W	0'h	DAC Path Right Channel 1 st EQ High Pass Filter1 Mode Control 0'b: High frequency shelving filter 1'b: 1 st order Butterworth HPF (-20dB per decade)
Da_eq_hpf1_tpy_l	8	R/W	0'h	DAC Path Left Channel 1 st EQ High Pass Filter1 Mode Control 0'b: High frequency shelving filter 1'b: 1 st order Butterworth HPF (-20dB per decade)
Da_eq_lpf1_en	7	R/W	0'h	DAC Path 1 st EQ Low Pass Filter (LPF2) Filter Control. 0'b: Disabled and reset 1'b: Enabled.

Name	Bits	Read/Write	Reset State	Description
Da_eq_hpf2_en	6	R/W	0'h	DAC Path EQ 2 nd High Pass Butterworth Filter (HPF) Control. 0'b: Disabled (bypass) and reset 1'b: Enabled
Da_eq_hpf1_en	5	R/W	0'h	DAC Path EQ 1 st High Pass Filter (HPF1) Control. 0'b: Disabled (bypass) and reset 1'b: Enabled
Da_eq_bpf4_en	4	R/W	0'h	DAC Path 2 nd EQ Band-4 (BP4) shelving Filter Control. 0'b: Disabled and reset 1'b: Enabled.
Da_eq_bpf3_en	3	R/W	0'h	DAC Path 2 nd EQ Band-3 (BP3) shelving Filter Control. 0'b: Disabled and reset 1'b: Enabled.
Da_eq_bpf2_en	2	R/W	0'h	DAC Path 2 nd EQ Band-2 (BP2) shelving Filter Control. 0'b: Disabled and reset 1'b: Enabled.
Eq_biquad_en	1	R/W	0'h	DAC Path 2 nd EQ Band-1 (Biquad Type) shelving Filter Control. 0'b: Disabled and reset 1'b: Enabled.
Reserved	0	R	0'h	Reserved

9.90. MX-B3h: DRC Control

Default: 001F'h

Table 106. MX-B3h: DRC Control

Name	Bits	Read/Write	Reset State	Description
reserved	15	R	0'h	Reserved
Alc_noise_gate_ht	14:12	R/W	0'h	ALC Noise Gate Hold Time Control 000'b: 0 sample 001'b: 128 samples 010'b: 256 samples ... 111'b: 896 samples
alc_ft_boost	11:6	R/W	0'h	ALC Digital Pre-BOOST (0.75dB/step) 00'h= 0dB 01'h= 0.75dB 02'h= 1.5dB 03'h= 2.25dB ... 27'h= 29.25dBFS Others: Reserved
alc_bk_gain_r	5:0	R/W	1f'h	ALC Right Channel Digital Post-BOOST (0.375dB/step) 00'h= -11.625dB ... 3F'h= 12dB

9.91. MX-B4h: DRC Control

Default: 0206'h

Table 107. MX-B4h: DRC Control

Name	Bits	Read/Write	Reset State	Description
sel_drc_agc	15:14	R/W	0'h	DRC Enable Control 00'b: Disable DRC 01'b: Enable DRC to DAC Path 10'b: Disable DRC 11'b: Enable DRC to ADC Path
Reserved	13	R	0'h	Reserved
sel_drc_agc_atk	12:8	R/W	2'h	Select DRC attack rate (0.375dB/TU)❶ 00'h: 83 uSec 01'h: 0.167 mSec ... 10'h: 5.46 Sec Others: Reserved
Drc_agc_rate_sel	7:5	R/W	0'h	DRC Rate Control for Sample Rate Change❷ 001'b: 48kHz 010'b: 96kHz 011'b: 192kHz 101'b: 44.1kHz 110'b: 88.2kHz 111'b: 176.4kHz Others: Reserved
sel_rc_rate	4:0	R/W	6'h	Select DRC recovery rate (0.375dB/TU)❸ 00'h: 83 uSec 01'h: 0.167 mSec ... 10'h: 5.46 Sec Others: Reserved

❶ attack time= $(4*2^n)/\text{Sample_Rate}$, n=MX-B4[12:8], default=0.33mS

❷ recovery time= $(4*2^n)/\text{Sample_Rate}$, n= MX-B4 [4:0], default=5.3mS

❸ When change I2S's sample rate, the DRC/AGC rate control is need to be changed same with I2S's sample rate. When change the DRC/AGC rate, the parameter of DRC/AGC isn't need be modified.

When I2S's sample rate is below 48kHz, that need to set the DRC/AGC rate to 48kHz and re-calculate the DRC/AGC's parameter by I2S's sample rate.

9.92. MX-B5h: DRC Control

Default: 1F00'h

Table 108. MX-B5h: DRC Control

Name	Bits	Read/Write	Reset State	Description
Alc_drc_ratio_sel2	15:14	R/W	0'h	DRC Compression-2 Ratio Selection 00'b: 1:1 01'b: 1:2 10'b: 1:4 11'b: 1:8
sel_drc_agc_post_bst	13:8	R/W	1f'h	DRC Digital Post-Boost Gain (0.375dB/step)❶ 00'h= -11.625dB ... 3F'h= 12dB Others: Reserved
En_drc_agc_compressions	7	R/W	0'h	DRC Compression Function Control 0'b: Disable 1'b: Enable
Sel_ratio	6:5	R/W	0'h	DRC Compression Ratio Selection 00'b: 1:1 01'b: 1:2 10'b: 1:4 11'b: 1:8
Alc_noise_gate_drop_en	4	R/W	0'h	DRC Noise Gate Drop Mode Control 0'b: Disable 1'b: Enable
Reserved	3:2	R	0'h	Reserved
noise_gate_ratio_sel	1:0	R/W	0'h	DRC Expansion Ratio Control when Noise Gate is Enabled 00'b: 1:1 01'b: 2:1 10'b: 4:1 11'b: 8:1

❶ Gain table:

DEC	HEX	Boost Gain	DEC	HEX	Boost Gain	DEC	HEX	Boost Gain	DEC	HEX	Boost Gain	DEC	HEX	Boost Gain
0	0	-11.625	16	10	-5.625	32	20	0.375	48	30	6.375	64	40	
1	1	-11.25	17	11	-5.25	33	21	0.75	49	31	6.75	65	41	
2	2	-10.875	18	12	-4.875	34	22	1.125	50	32	7.125	66	42	
3	3	-10.5	19	13	-4.5	35	23	1.5	51	33	7.5	67	43	
4	4	-10.125	20	14	-4.125	36	24	1.875	52	34	7.875	68	44	

5	5	-9.75	21	15	-3.75	37	25	2.25	53	35	8.25	69	45	
6	6	-9.375	22	16	-3.375	38	26	2.625	54	36	8.625	70	46	
7	7	-9	23	17	-3	39	27	3	55	37	9	71	47	
8	8	-8.625	24	18	-2.625	40	28	3.375	56	38	9.375	72	48	
9	9	-8.25	25	19	-2.25	41	29	3.75	57	39	9.75	73	49	
10	A	-7.875	26	1A	-1.875	42	2A	4.125	58	3A	10.125	74	4A	
11	B	-7.5	27	1B	-1.5	43	2B	4.5	59	3B	10.5	75	4B	
12	C	-7.125	28	1C	-1.125	44	2C	4.875	60	3C	10.875	76	4C	
13	D	-6.75	29	1D	-0.75	45	2D	5.25	61	3D	11.25			
14	E	-6.375	30	1E	-0.375	46	2E	5.625	62	3E	11.625			
15	F	-6	31	1F	0	47	2F	6	63	3F	12			

9.93. MX-B6h: DRC Control

Default: 0000'h

Table 109. MX-B6h: DRC Control

Name	Bits	Read/Write	Reset State	Description
Noise_gate_boost	15:12	R/W	0'h	Select Compensation Gain When Signal is Below Noise Gate 0'h: 0dB 1'h: 3dB 2'h: 6dB ... E'h: 42dB F'h: 45dB
Reserved	11	R	0'h	Reserved
drc_thmin	10:5	R/W	0'h	DRC Threshold Level Control 00'h: -60dB 01'h: -60.75dB 02'h: -61.5dB ... 2E'h: -94.5dB, with 0.75dB/step
sel_drc_agc_noise_th	4:0	R/W	0'h	Noise Gate Threshold (-1.5dB/step) 00'h: -24dBFS 01'h: -25.5dBFS 1F'h: -70.5 dBFS

9.94. MX-B7h: DRC Control

Default: 4000'h

Table 110. MX-B7h: DRC Control

Name	Bits	Read/Write	Reset State	Description
Reserved	15	R	0'h	Reserved
Alc_thmin_fast_re_en	14	R/W	1'h	DRC THMIN Mode Fast Recover Control 0'b: Disable 1'b: Enable
Alc_noise_gate_en	13	R/W	0'h	Noise Gate Function Control 0'b: Disable 1'b: Enable
reserved	12	R/W	0'h	Reserved
alc_thmax2	11:6	R/W	0'h	DRC Limiter Threshold 2 Control (0.75dB/step) 00'h= 0dBFS 01'h= -0.75dBFS 02'h= -1.5dBFS 03'h= -2.25dBFS 1F'h= -45dBFS
alc_thmax	5:0	R/W	0'h	DRC Limiter Threshold Control (0.375dB/step) 00'h= 0dBFS 01'h= -0.375dBFS 02'h= -0.75dBFS 03'h= -1.125dBFS 1F'h= -23.625dBFS

9.95. MX-BBh: Jack Detection Control

Default: 0000'h

Table 111. MX-BBh: Jack Detection Control

Name	Bits	Read/Write	Reset State	Description
sel_gpio_jd1	15:13	R/W	0'h	GPIO Jack Detect – 1 Source Selection 000'b: OFF 001'b: GPIO3 010'b: GPIO4 011'b: GPIO5 100'b: GPIO6 101'b: Reserved 110'b: Reserved 111'b: Reserved
reserved	12	R	0'h	reserved
en_jd_hpo	11	R/W	0'h	Enable jack detect trigger HPOUT 0'b: Disable 1'b: Enable
polarity_jd_tri_hpo	10	R/W	0'h	Select jack detect polarity trigger HPOUT 0'b: Low trigger 1'b: High trigger
en_jd_spk_l	9	R/W	0'h	Enable jack detect trigger SPK_L 0'b: Disable 1'b: Enable
polarity_jd_tri_spk_l	8	R/W	0'h	Select jack detect polarity trigger SPK_L 0'b: Low trigger 1'b: High trigger
en_jd_spk_r	7	R/W	0'h	Enable jack detect trigger SPK_R 0'b: Disable 1'b: Enable
polarity_jd_tri_spk_r	6	R/W	0'h	Select jack detect polarity trigger SPK_R 0'b: Low trigger 1'b: High trigger
Reserved	5:4	R/W	0'h	Reserved
en_jd_lout1	3	R/W	0'h	Enable jack detect trigger LOUT1 0'b: Disable 1'b: Enable
polarity_jd_tri_lout1	2	R/W	0'h	Select jack detect polarity trigger LOUT1 0'b: Low trigger 1'b: High trigger
Reserved	1:0	R	0'h	Reserved

9.96. MX-BCh: Jack Detection Control

Default: 0000'h

Table 112. MX-BCh: Jack Detection Control

Name	Bits	Read/Write	Reset State	Description
En_jd_pdm_l	15	R/W	0'h	Enable jack detect trigger PDM_L 0'b: Disable 1'b: Enable
Polarity_jd_tri_pdm_l	14	R/W	0'h	Select jack detect polarity trigger PDM_L 0'b: Low trigger 1'b: High trigger
En_jd_pdm_r	13	R/W	0'h	Enable jack detect trigger PDM_R 0'b: Disable 1'b: Enable
Polarity_jd_tri_pdm_r	12	R/W	0'h	Select jack detect polarity trigger PDM_R 0'b: Low trigger 1'b: High trigger
Reserved	11:0	R	0'h	Reserved

9.97. MX-BDh: IRQ Control 1

Default: 0000'h

Table 113. MX-BDh: IRQ Control 1

Name	Bits	Read/Write	Reset State	Description
en_irq_gpio_jd1	15	R/W	0'h	IRQ Output Source Configure of GPIO Jack Detection 1 Status 0'b: bypass 1'b: Normal
en_gpio_jd1_sticky	14	R/W	0'h	Sticky Control for GPIO Jack Detect 1 0'b: Disable 1'b: Enable
inv_gpio_jd1	13	R/W	0'h	GPIO Jack Detection 1 Status Polarity 0'b: Normal 1'b: Output Invert
reserved	12:10	R/W	0'h	Reserved
en_irq_jd1_1	9	R/W	0'h	IRQ Output Source Configure of JD1_1 Jack Detection Status 0'b: bypass 1'b: Normal
en_jd1_1_sticky	8	R/W	0'h	Sticky Control for JD1_1 Jack Detect 0'b: Disable 1'b: Enable
inv_jd1_1	7	R/W	0'h	JD1_1 Jack Detection Status Polarity 0'b: Normal 1'b: Output Invert

Name	Bits	Read/Write	Reset State	Description
en_irq_jd1_2	6	R/W	0'h	IRQ Output Source Configure of JD1_2 Jack Detection Status 0'b: bypass 1'b: Normal
en_jd1_2_sticky	5	R/W	0'h	Sticky Control for JD1_2 Jack Detect 0'b: Disable 1'b: Enable
inv_jd1_2	4	R/W	0'h	JD1_2 Jack Detection Status Polarity 0'b: Normal 1'b: Output Invert
en_irq_jd2	3	R/W	0'h	IRQ Output Source Configure of JD2 Jack Detection Status 0'b: bypass 1'b: Normal
en_jd2_sticky	2	R/W	0'h	Sticky Control for JD2 Jack Detect 0'b: Disable 1'b: Enable
inv_jd2	1	R/W	0'h	JD2 Jack Detection Status Polarity 0'b: Normal 1'b: Output Invert
reserved	0	R	0'h	Reserved

9.98. MX-BEH: IRQ Control 2

Default: 0000'h

Table 114. MX-BEH: IRQ Control 2

Name	Bits	Read/Write	Reset State	Description
en_irq_micbias1_ovcd	15	R/W	0'h	IRQ Output Source Configure of MICBIAS1 Over Current Status 0'b: bypass 1'b: Normal
en_irq_micbias2_ovcd	14	R/W	0'h	IRQ Output Source Configure of MICBIAS2 Over Current Status 0'b: bypass 1'b: Normal
en_micbias1_ovcd_sticky	13	R/W	0'h	Sticky Control for MICBIAS1 Over Current 0'b: Disable 1'b: Enable
en_micbias2_ovcd_sticky	12	R/W	0'h	Sticky Control for MICBIAS2 Over Current 0'b: Disable 1'b: Enable
inv_micbias1_ovcd	11	R/W	0'h	MICBIAS1 over current status polarity 0'b: Normal 1'b: Output Invert
inv_micbias2_ovcd	10	R/W	0'h	MICBIAS2 over current status polarity 0'b: Normal 1'b: Output Invert

Name	Bits	Read/Write	Reset State	Description
Sta_micbias1_ovcd	9	R	0'h	MICBIAS1 over current status Read: return status of each status pin Write: Write '0' to clear stick bit
Sta_micbias2_ovcd	8	R	0'h	MICBIAS2 over current status Read: return status of each status pin Write: Write '0' to clear stick bit
reserved	7:3	R/W	0'h	Reserved
Ovcl_clsd	2	R	0'h	Class-D Left Channel Over-Current Status 0'b: Normal 1'b: OC
Over_clsd	1	R	0'h	Class-D Right Channel Over-Current Status 0'b: Normal 1'b: OC
Sta_ovcd	0	R	0'h	Class-D Amp Over-Current Status 0'b: Normal 1'b: OC

9.99. MX-BFh: IRQ Control 3

Default: 0000'h

Table 115. MX-BFh: IRQ Control 3

Name	Bits	Read/Write	Reset State	Description
reserved	15	R	0'h	Reserved
sta_jd2	14	R	0'h	Status of JD2 Jack detection . Read: Return status of Jack Detect Select output Write: Write '0' to clear stick bit
sta_jd1_2	13	R	0'h	Status of JD1_2 Jack detection . Read: Return status of Jack Detect Select output Write: Write '0' to clear stick bit
sta_jd1_1	12	R	0'h	Status of JD1_1 Jack detection . Read: Return status of Jack Detect Select output Write: Write '0' to clear stick bit
Ovt_status	11	R	0'h	Class-D Amp Over-Temperature Status 0'b: Normal 1'b: OT
sta_gpio6	10	R	0'h	GPIO6 Pin Status Read: return status of each GPIO pin
sta_gpio5	9	R	0'h	GPIO5 Pin Status Read: return status of each GPIO pin
sta_gpio1	8	R	0'h	GPIO1 Pin Status Read: return status of each GPIO pin
sta_gpio2	7	R	0'h	GPIO2 Pin Status Read: return status of each GPIO pin
sta_gpio3	6	R	0'h	GPIO3 Pin Status Read: return status of each GPIO pin
sta_gpio4	5	R	0'h	GPIO4 Pin Status Read: return status of each GPIO pin

Name	Bits	Read/Write	Reset State	Description
sta_gpio_jd1	4	R	0'h	Status of GPIO Jack detection 1 Read: Return status of Jack Detect Select output Write: Write '0' to clear stick bit
en_irq_inline	3	R/W	0'h	IRQ Output Source Configure of InLine Command Status 0'b: bypass 1'b: Normal
sta_inline	2	R	0'h	Status of InLine Command Trigger Read: Return status of InLine Command Trigger Write: Write '0' to clear stick bit
en_inline_sticky	1	R/W	0'h	Sticky Control for InLine Command 0'b: Disable 1'b: Enable
inv_inline	0	R/W	0'h	InLine Command Status Polarity 0'b: Normal 1'b: Output Invert

9.100. MX-C0h: GPIO Control 1

Default: 0000'h

Table 116. MX-C0h: GPIO Control 1

Name	Bits	Read/Write	Reset State	Description
sel_gpio1_type	15	R/W	0'h	GPIO1 Pin Function Select 0'b: GPIO1 1'b: IRQ output
sel_gpio2_type	14	R/W	0'h	GPIO2 Pin Function Select 0'b: GPIO2 1'b: DMIC1_SCL
Reserved	13	R	0'h	Reserved
sel_gpio3_type	12	R/W	0'h	GPIO3 Pin Function Select 0'b: GPIO3 1'b: PDM_SCL
sel_gpio4_type	11	R/W	0'h	GPIO4 Pin Function Select 0'b: GPIO4 1'b: PDM_SDA
Reserved	10:9	R/W	0'h	Reserved
Sel_i2s2_pin	8	R/W	0'h	I2S-2 Pin Function Selection 0'b: I2S function pins 1'b: GPIO function pins
sel_gpio5_type	7	R/W	0'h	GPIO5 Pin Function Select 0'b: GPIO5 1'b: DMIC1_SDA
sel_gpio6_type	6	R/W	0'h	GPIO6 Pin Function Select 0'b: GPIO6 1'b: DMIC2_SDA
Reserved	5:0	R/W	0'h	Reserved

9.101. MX-C1h: GPIO Control 2

Default: 0000'h

Table 117. MX-C1h: GPIO Control 2

Name	Bits	Read/Write	Reset State	Description
reserved	15	R/W	0'h	Reserved
sel_gpio5	14	R/W	0'h	GPIO5 Pin Configuration 0'b: Input 1'b: Output
sel_gpio5_logic	13	R/W	0'h	GPIO5 Output Pin Control 0'b: Drive Low 1'b: Drive High
inv_gpio5	12	R/W	0'h	GPIO5 Pin Polarity 0'b: Normal 1'b: Output Invert
sel_gpio4	11	R/W	0'h	GPIO4 Pin Configuration 0'b: Input 1'b: Output
sel_gpio4_logic	10	R/W	0'h	GPIO4 Output Pin Control 0'b: Drive Low 1'b: Drive High
inv_gpio4	9	R/W	0'h	GPIO4 Pin Polarity 0'b: Normal 1'b: Output Invert
sel_gpio3	8	R/W	0'h	GPIO3 Pin Configuration 0'b: Input 1'b: Output
sel_gpio3_logic	7	R/W	0'h	GPIO3 Output Pin Control 0'b: Drive Low 1'b: Drive High
inv_gpio3	6	R/W	0'h	GPIO3 Pin Polarity 0'b: Normal 1'b: Output Invert
sel_gpio2	5	R/W	0'h	GPIO2 Pin Configuration 0'b: Input 1'b: Output
sel_gpio2_logic	4	R/W	0'h	GPIO2 Output Pin Control 0'b: Drive Low 1'b: Drive High
inv_gpio2	3	R/W	0'h	GPIO2 Pin Polarity 0'b: Normal 1'b: Output Invert
sel_gpio1	2	R/W	0'h	GPIO1 Pin Configuration 0'b: Input 1'b: Output
sel_gpio1_logic	1	R/W	0'h	GPIO1 Output Pin Control 0'b: Drive Low 1'b: Drive High

Name	Bits	Read/Write	Reset State	Description
inv_gpio1	0	R/W	0'h	GPIO1 Pin Polarity 0'b: Normal 1'b: Output Invert

9.102. MX-C2h: GPIO Control 3

Default: 0000'h

Table 118. MX-C2h: GPIO Control 3

Name	Bits	Read/Write	Reset State	Description
reserved	15:3	R/W	0'h	Reserved
sel_gpio6	2	R/W	0'h	GPIO6 Pin Configuration 0'b: Input 1'b: Output
sel_gpio6_logic	1	R/W	0'h	GPIO6 Output Pin Control 0'b: Drive Low 1'b: Drive High
inv_gpio6	0	R/W	0'h	GPIO6 Pin Polarity 0'b: Normal 1'b: Output Invert

9.103. MX-CFh: SounzReal™ BassBack Control

Default: 0013'h

Table 119. MX-CFh: SounzReal™ BassBack Control

Name	Bits	Read/Write	Reset State	Description
En_bb	15	R/W	0'h	Enable BassBack Function 0'b: Disable 1'b: Enable
Sel_bb_coef	14:12	R/W	0'h	Select Control for BassBack Coefficient Type 000'b: Type A 001'b: Type B 010'b: Type C 011'b: Type D 1xx'b: Reserved
Reserved	11:6	R	0'h	Reserved
Bb_boost_gain	5:0	R/W	13'h	Select Control BassBack Boost Gain 000001'b: 1.5dB 000010'b: 3dB 010011'b: 24dB 011111'b: 42dB, with 1.5dB/Step

9.104. MX-D0h: SounzReal™ TruTreble Control 1

Default: 0680'h

Table 120. MX-D0h: SounzReal™ TruTreble Control 1

Name	Bits	Read/Write	Reset State	Description
reserved	15:14	R/W	0'h	Reserved
En_mp	13	R/W	0'h	Enable TruTreble Function 0'b: Disable 1'b: Enable
Mp_eg	12:8	R/W	6'h	TruTreble Enhanced Gain Control ① 00000'b: -11.625dB 00001'b: -10.5dB 00110'b: -3dB 10100'b: 7.5dB
reserved	7:0	R/W	80'h	Reserved

①

Eg	Enhanced Gain	Eg	Enhanced Gain
1	-11.625dB	11	2.25 dB
2	-10.5 dB	12	3 dB
3	-9 dB	13	3.75 dB
4	-6.75 dB	14	4.5 dB
5	-4.5 dB	15	4.875 dB
6	-3 dB	16	5.625 dB
7	-1.875 dB	17	6 dB
8	-0.375 dB	18	6.375 dB
9	0.375 dB	19	7.125 dB
10	1.5 dB	20	7.5 dB

9.105. MX-D1h: SounzReal™ TruTreble Control 2

Default: 1C17'h

Table 121. MX-D1h: SounzReal™ TruTreble Control 2

Name	Bits	Read/Write	Reset State	Description
reserved	15:14	R	0'h	Reserved
mp_hp_wt	13	R/W	0'h	Select The Harmonic Weighting 0'b: a = 1/4(default) 1'b: a = 1/2

Name	Bits	Read/Write	Reset State	Description
mp_og	12:8	R/W	1C'h	Select The Origin Signal Gain 00000'b: -5.8125dB 00001'b: -5.625dB ... 10111'b: -0.5625 dB ... 11111'b: 12dB, with 0.1875dB/Step
reserved	7:6	R	0'h	Reserved
mp_hg	5:0	R/W	17'h	Select High Frequency Harmonic Gain (0.375 /step) 000000'b: -11.625dB 000001'b: -11.25dB ... 010111'b: -3dB ... 111111'b: 12dB, with 0.375dB/Step

9.106. MX-D3h: Stereo1 ADC Wind Filter Control 1

Default: A220'h

Table 122. MX-D3h: Stereo1 ADC Wind Filter Control 1

Name	Bits	Read/Write	Reset State	Description
adj_hpf_2 nd _en_stereo1	15	R/W	1'h	Stereo1 ADC Wind Filter Enable Control 0'b : Disable and bypass 1'b : Enable

Name	Bits	Read/Write	Reset State	Description
adj_hpf_coef_l_sel_stereo1	14:12	R/W	2'h	Stereo1 ADC Wind Filter Left Channel Coefficient Coarse Selection 000'b : fs=8k, fc = 20~2000Hz fs=12k, fc = 30~3000Hz fs=16k, fc = 40~4000Hz 001'b : fs=24k, fc = 30~2458Hz fs=32k, fc = 40~3278Hz 010'b : fs=44.1k, fc = 28~1992Hz fs=48k, fc = 30~2168Hz 011'b : fs=88.2k, fc = 28~1869Hz fs=96k, fc = 30~2034Hz 100'b : fs=176.4k, fc = 27~1811Hz fs=192k, fc = 30~1971Hz Others: Reserved
Reserved	11	R	0'h	Reserved
adj_hpf_coef_r_sel_stereo1	10:8	R/W	2'h	Stereo1 ADC Wind Filter Right Channel Coefficient Coarse Selection 000'b : fs=8k, fc = 20~2000Hz fs=12k, fc = 30~3000Hz fs=16k, fc = 40~4000Hz 001'b : fs=24k, fc = 30~2458Hz fs=32k, fc = 40~3278Hz 010'b : fs=44.1k, fc = 28~1992Hz fs=48k, fc = 30~2168Hz 011'b : fs=88.2k, fc = 28~1869Hz fs=96k, fc = 30~2034Hz 100'b : fs=176.4k, fc = 27~1811Hz fs=192k, fc = 30~1971Hz Others: Reserved
reserved	7:0	R/W	20'h	Reserved

9.107. MX-D4h: Stereo1 ADC Wind Filter Control 2

Default: 0000'h

Table 123. MX-D4h: Stereo1 ADC Wind Filter Control 2

Name	Bits	Read/Write	Reset State	Description
reserved	15:14	R	0'h	Reserved

Name	Bits	Read/Write	Reset State	Description
adj_hpf_coef_l_num_stereo1	13:8	R/W	0'h	Stereo1 ADC Wind Filter Right Channel Coefficient Fine Selection (0~63)
reserved	7:6	R	0'h	Reserved
adj_hpf_coef_r_num_stereo1	5:0	R/W	0'h	Stereo1 ADC Wind Filter Left Channel Coefficient Fine Selection (0~63)

9.108. MX-D6h: HP Amp Control

Default: 0400'h

Table 124. MX-D6h: HP Amp Control

Name	Bits	Read/Write	Reset State	Description
reserved	15:6	R/W	0'h	Reserved
En_hp_amp_detect	5	R/W	0'h	Enable Headphone Amp Amplitude Detection 0'b: Disable 1'b: Enable
reserved	4:0	R/W	0'h	Reserved

9.109. MX-D9h: Soft Volume & ZCD Control 1

Default: 0809'h

Table 125. MX-D9h: Soft Volume & ZCD Control 1

Name	Bits	Read/Write	Reset State	Description
en_softvol	15	R/W	0'h	Digital Soft Volume Delay Control 0'b: Disable 1'b: Enable
reserved	14	R/W	0'h	Reserved
en_o_svol	13	R/W	0'h	OUTVOLL/R Soft Volume Delay Control 0'b: Disable 1'b: Enable
en_hpo_svol	12	R/W	0'h	HPOVOLL/R Soft Volume Delay Control 0'b: Disable 1'b: Enable
en_zcd_digital	11	R/W	1'h	Digital Volume Zero Crossing Detection Control 0'b: Disable 1'b: Enable
pow_zcd	10	R/W	0'h	Power On Zero Crossing 0'b: Power Down 1'b: Power On
reserved	9	R	0'h	Reserved
en_spo_svol	8	R/W	0'h	SPOVOLL/R Soft Volume Delay Control 0'b: Disable 1'b: Enable
reserved	7:4	R	0'h	Reserved

Name	Bits	Read/Write	Reset State	Description
sel_svol	3:0	R/W	9'h	Soft Volume Change Delay Time 0000: 1 SVSYNC 0001: 2 SVSYNC 0010: 4 SVSYNC 0011: 8 SVSYNC 0100: 16 SVSYNC 0101: 32 SVSYNC 0110: 64 SVSYNC 0111: 128 SVSYNC 1000: 256 SVSYNC 1001: 512 SVSYNC 1010: 1024 SVSYNC Others: Reserved Note: SVSYNC=1/Fs, Step:-1.5dBFS

9.110. MX-DAh: Soft Volume & ZCD Control 2

Default: 0000'h

Table 126. MX-DAh: Soft Volume & ZCD Control 2

Name	Bits	Read/Write	Reset State	Description
reserved	15:9	R/W	0'h	Reserved
en_zcd_hpmixr	8	R/W	0'h	HPMIXR ZCD Control 0'b: Disable 1'b: Enable
en_zcd_hpmixl	7	R/W	0'h	HPMIXL ZCD Control 0'b: Disable 1'b: Enable
reserved	6	R/W	0'h	Reserved
en_zcd_outmixr	5	R/W	0'h	OUTMIXR ZCD Control 0'b: Disable 1'b: Enable
en_zcd_outmixl	4	R/W	0'h	OUTMIXL ZCD Control 0'b: Disable 1'b: Enable
en_zcd_spkmixr	3	R/W	0'h	SPKMIXR ZCD Control 0'b: Disable 1'b: Enable
en_zcd_spkmixl	2	R/W	0'h	SPKMIXL ZCD Control 0'b: Disable 1'b: Enable
en_zcd_recmixr	1	R/W	0'h	RECMIXR ZCD Control 0'b: Disable 1'b: Enable
en_zcd_recmixl	0	R/W	0'h	RECMIXL ZCD Control 0'b: Disable 1'b: Enable

9.111. MX-DBh: Inline Command Control 1

Default: 0001'h

Table 127. MX-DBh: Inline Command Control 1

Name	Bits	Read/Write	Reset State	Description
sta_one_up_button	15	R	0'h	Status of One Click Command for Up Button Write "1" to clear it
sta_double_up_button	14	R	0'h	Status of Double Click Command for Up Button Write "1" to clear it
sta_hold_up_button	13	R	0'h	Status of Hold Command for Up Button Write "1" to clear it
sta_one_center_button	12	R	0'h	Status of One Click Command for Center Button Write "1" to clear it
sta_double_center_button	11	R	0'h	Status of Double Click Command for Center Button Write "1" to clear it
sta_hold_center_button	10	R	0'h	Status of Hold Command for Center Button Write "1" to clear it
sta_one_down_button	9	R	0'h	Status of One Click Command for Down Button Write "1" to clear it
sta_double_down_button	8	R	0'h	Status of Double Click Command for Down Button Write "1" to clear it
sta_hold_down_button	7	R	0'h	Status of Hold Command for Down Button Write "1" to clear it
reserved	6	R	0'h	Reserved
Irq_inline	5	R/W	0'h	IRQ Output Enable Control by Inline Command 0'b: Disable 1'b: Enable
Sel_clk_mic	4:3	R/W	0'h	Select InLine Command Debounce Clock 00'b: OSC/2 ¹⁷ 01'b: OSC/2 ¹⁶ 10'b: OSC/2 ¹⁵ 11'b: OSC/2 ¹⁴
Mic_in_det_0_th	2:0	R/W	1'h	MIC Input Voltage Control (CMP0) 000'b: 0.027V 001'b: 0.054V 010'b: 0.081V 011'b: 0.108V 100'b: 0.135V 101'b: 0.162V 110'b: 0.189V 111'b: 0.216V

9.112. MX-DCh: Inline Command Control 2

Default: 0049'h

Table 128. MX-DCh: Inline Command Control 2

Name	Bits	Read/Write	Reset State	Description
en_inline_vol	15	R/W	0'h	Enable Inline Command Direct to Control Digital Volume 0'b: Disable 1'b: Enable
sel_inline_ctl_if	14	R/W	0'h	Select The Inline Command Control Path 0'b: IF1 DAC Volume/Mute(Un-Mute) 1'b: IF2 DAC Volume/Mute(Un-Mute)
Conti_hold_up	13	R/W	0'h	Select Hold Command Behavior for Up Button 0'b: One pulse trigger 1'b: Continue pulse trigger
Conti_hold_center	12	R/W	0'h	Select Hold Command Behavior for Center Button 0'b: One pulse trigger 1'b: Continue pulse trigger
Conti_hold_down	11	R/W	0'h	Select Hold Command Behavior for Down Button 0'b: One pulse trigger 1'b: Continue pulse trigger
in_det_window	10:0	R/W	49'h	Inline Command Click Window Control MX-DB[4:3]=00'b => (1/OSC)*16384*n MX-DB[4:3]=01'b => (1/OSC)*8192*n MX-DB[4:3]=10'b => (1/OSC)*4096*n MX-DB[4:3]=11'b => (1/OSC)*2048*n (n=0~127)

9.113. MX-DDh: Inline Command Control 3

Default: 0009'h

Table 129. MX-DDh: Inline Command Control 3

Name	Bits	Read/Write	Reset State	Description
Reserved	15:6	R	0'h	Reserved
Mic_in_det_1_th	5:3	R/W	1'h	MIC Input Voltage Control (CMP1) 000'b: 0.324V 001'b: 0.351V 010'b: 0.378V 011'b: 0.405V 100'b: 0.432V 101'b: 0.459V 110'b: 0.486V 111'b: 0.513V

Name	Bits	Read/Write	Reset State	Description
Mic_in_det_2_th	2:0	R/W	1'h	MIC Input Voltage Control (CMP2) 000'b: 1.134V 001'b: 1.188V 010'b: 1.242V 011'b: 1.296V 100'b: 1.350V 101'b: 1.404V 110'b: 1.458V 111'b: 1.512V

9.114. MX-E7h: DRC Limiter Control

Default: 0200'h

Table 130. MX-E7h: DRC Limiter Control

Name	Bits	Read/Write	Reset State	Description
reserved	15:11	R	0'h	Reserved
Alc_limiter_ratio	10:8	R/W	2'h	DRC Limiter Ratio Control 000'b: 1/4 001'b: 1/8 010'b: 1/26 011'b: 1/32 100'b: 1/64 101'b: 1/128 110'b: 1/256 111'b: Hard Limiter
reserved	7:0	R/W	0'h	Reserved

9.115. MX-E9h: DRC Bass Limiter Control

Default: 0200'h

Table 131. MX-E9h: DRC Bass Limiter Control

Name	Bits	Read/Write	Reset State	Description
reserved	15:11	R	0'h	Reserved
Alc_bass_limiter_ratio	10:8	R/W	2'h	DRC Bass Band Limiter Ratio Control 000'b: 1/4 001'b: 1/8 010'b: 1/26 011'b: 1/32 100'b: 1/64 101'b: 1/128 110'b: 1/256 111'b: Hard Limiter
reserved	7:0	R/W	0'h	Reserved

9.116. MX-EAh: DRC Control

Default: 0F20'h

Table 132. MX-EAh: DRC Control

Name	Bits	Read/Write	Reset State	Description
reserved	15:12	R/W	0'h	Reserved
Mbdrc_bass_mute_front_l	11	R/W	1'h	Multi-Band DRC_L Front Mixer Mute Control 0'b: Un-mute 1'b: Mute
Mbdrc_bass_mute_front_r	10	R/W	1'h	Multi-Band DRC_R Front Mixer Mute Control 0'b: Un-mute 1'b: Mute
Mbdrc_bass_mute_back_l	9	R/W	1'h	Multi-Band Bass DRC_L Back Mixer Mute Control 0'b: Un-mute 1'b: Mute
Mbdrc_bass_mute_back_r	8	R/W	1'h	Multi-Band Bass DRC_R Back Mixer Mute Control 0'b: Un-mute 1'b: Mute
reserved	7:6	R/W	0'h	Reserved
Mbdrc_front_mix_sel	5	R/W	0'h	Multi-Band DRC Front Mixer Output Control 0'b: Divide by 2 1'b: Clipping
reserved	4:0	R/W	0'h	Reserved

9.117. MX-ECh: Mono ADC Wind Filter Control 1

Default: B300'h

Table 133. MX-ECh: Mono ADC Wind Filter Control 1

Name	Bits	Read/Write	Reset State	Description
adj_hpf_2 nd _en_mono	15	R/W	1'h	Mono ADC Wind Filter Enable Control 0'b : Disable and bypass 1'b : Enable

Name	Bits	Read/Write	Reset State	Description
adj_hpf_coef_l_sel_mono	14:12	R/W	3'h	Mono ADC Wind Filter Left Channel Coefficient Coarse Selection 000'b : fs=8k, fc = 20~2000Hz fs=12k, fc = 30~3000Hz fs=16k, fc = 40~4000Hz 001'b : fs=24k, fc = 30~2458Hz fs=32k, fc = 40~3278Hz 010'b : fs=44.1k, fc = 28~1992Hz fs=48k, fc = 30~2168Hz 011'b : fs=88.2k, fc = 28~1869Hz fs=96k, fc = 30~2034Hz 100'b : fs=176.4k, fc = 27~1811Hz fs=192k, fc = 30~1971Hz Others: Reserved
Reserved	11	R	0'h	Reserved
adj_hpf_coef_r_sel_mono	10:8	R/W	3'h	Mono ADC Wind Filter Right Channel Coefficient Coarse Selection 000'b : fs=8k, fc = 20~2000Hz fs=12k, fc = 30~3000Hz fs=16k, fc = 40~4000Hz 001'b : fs=24k, fc = 30~2458Hz fs=32k, fc = 40~3278Hz 010'b : fs=44.1k, fc = 28~1992Hz fs=48k, fc = 30~2168Hz 011'b : fs=88.2k, fc = 28~1869Hz fs=96k, fc = 30~2034Hz 100'b : fs=176.4k, fc = 27~1811Hz fs=192k, fc = 30~1971Hz Others: Reserved
reserved	7:0	R	0'h	Reserved

9.118. MX-EDh: Mono ADC Wind Filter Control 2

Default: 0000'h

Table 134. MX-EDh: Mono ADC Wind Filter Control 2

Name	Bits	Read/Write	Reset State	Description
reserved	15:14	R	0'h	Reserved

Name	Bits	Read/Write	Reset State	Description
adj_hpf_coef_l_num_mono	13:8	R/W	0'h	Mono ADC Wind Filter Right Channel Coefficient Fine Selection (0~63)
Reserved	7:6	R	0'h	Reserved
adj_hpf_coef_r_num_mono	5:0	R/W	0'h	Mono ADC Wind Filter Left Channel Coefficient Fine Selection (0~63)

9.119. MX-F0h: DRC Bass Control

Default: 001F'h

Table 135. MX-F0h: DRC Bass Control

Name	Bits	Read/Write	Reset State	Description
reserved	15	R	0'h	Reserved
Alc_bass_noise_gate_ht	14:12	R/W	0'h	DRC Bass Band Noise Gate Hold Time Control 000'b: 0 sample 001'b: 128 samples 010'b: 256 samples 011'b: 384 samples 100'b: 512 samples 101'b: 640 samples 110'b: 768 samples 111'b: 896 samples
Alc_bass_ft_boost	11:6	R/W	0'h	DRC Bass Band Pre-Boost Gain Control 00'h: 0dB 01'h: 0.75dB 02'h: 1.5dB ... 27'h: 29.25dB, with 0.75dB/step Others: Reserved
Alc_bass_bk_gain_r	5:0	R/W	1F'h	DRC Bass Band Post-Boost Gain Control (Right Channel) 00'h: -11.625dB 01'h: -11.25dB 02'h: -10.875dB ... 3F'h: 12dB, with 0.375dB/step Others: Reserved

9.120. MX-F1h: DRC Bass Control

Default: 0206'h

Table 136. MX-F1h: DRC Bass Control

Name	Bits	Read/Write	Reset State	Description
reserved	15:13	R	0'h	Reserved

Name	Bits	Read/Write	Reset State	Description
Alc_bass_atk_rate	12:8	R/W	2'h	DRC Bass Band Attack Rate Control 00'h: 83us 01'h: 0.167 ms ... 1F'h: 5.46s
Sel_Alc_bass_rate	7:5	R/W	0'h	DRC Bass Band Sample Rate Control 000'b: 48KHz 010'b: 96KHz 011'b: 192KHz 101'b: 44.1KHz 110'b: 88.2KHz 111'b: 176.4KHz Others: Reserved
Alc_bass_rc_slow_rate	4:0	R/W	C'h	DRC Bass Band Recovery Rate Control 00'h: 83us 01'h: 0.167 ms ... 1F'h: 5.46s

9.121. MX-F2h: DRC Bass Control

Default: 1F00'h

Table 137. MX-F2h: DRC Bass Control

Name	Bits	Read/Write	Reset State	Description
Alc_bass_drc_ratio_sel2	15:14	R/W	0'h	DRC Bass Band Compression2 Ratio Control 00'b: 1:1 01'b: 1:2 10'b: 1:4 11'b: 1:8
Alc_bass_bk_gain_l	13:8	R/W	1F'h	DRC Bass Band Post-Boost Gain Control (Left Channel) 00'h: -11.625dB 01'h: -11.25dB 02'h: -10.875dB ... 3F'h: 12dB, with 0.375dB/step Others: Reserved
Alc_bass_drc_en	7	R/W	0'h	DRC Bass Band Power Control 0'b: Disable 1'b: Enable
Alc_bass_drc_ratio_sel1	6:5	R/W	0'h	DRC Bass Band Compression1 Ratio Control 00'b: 1:1 01'b: 1:2 10'b: 1:4 11'b: 1:8
Alc_bass_noise_gate_drop_en	4	R/W	0'h	DRC Bass Band Noise Gate Drop Mode Control 0'b: Disable 1'b: Enable

Name	Bits	Read/Write	Reset State	Description
reserved	3:2	R	0'h	Reserved
Alc_bass_noise_gate_sel	1:0	R/W	0'h	DRC Bass Band Noise Gate Expansion Ratio Control 00'b: 1:1 01'b: 2:1 10'b: 4:1 11'b: 8:1

9.122. MX-F3h: DRC Bass Control

Default: 0000'h

Table 138. MX-F3h: DRC Bass Control

Name	Bits	Read/Write	Reset State	Description
Alc_bass_noise_gate_exp	15:12	R/W	0'h	DRC Bass Band Noise Gate Boost Compensation Gain Control 0'h: 0dB 1'h: 3dB 2'h: 6dB ... F'h: 45dB
reserved	11	R	0'h	Reserved
Alc_bass_thmin	10:5	R/W	0'h	DRC Bass Band Threshold Level Control 00'h: -60dB 01'h: -60.75dB 02'h: -61.5dB ... 2E'h: -94.5dB, with 0.75dB/step Others: Reserved
Alc_bass_thnoise	4:0	R/W	0'h	DRC Bass Band Noise Gate Threshold Control 00'h: -24dB 01'h: -25.5dB ... 1F'h: -70.5dB, with 1.5dB/step

9.123. MX-F4h: DRC Bass Control

Default: 4000'h

Table 139. MX-F4h: DRC Bass Control

Name	Bits	Read/Write	Reset State	Description
reserved	15	R	0'h	Reserved

Name	Bits	Read/Write	Reset State	Description
Alc_bass_thmin_fast_rc_en	14	R/W	1'h	DRC Bass Band THMIN Mode Fast Recovery Control 0'b: Disable 1'b: Enable
Alc_bass_noise_gate_en	13	R/W	0'h	DRC Bass Band Noise Gate Function Control 0'b: Disable 1'b: Enable
reserved	12	R/W	0'h	Reserved
Alc_bass_thmax2	11:6	R/W	0'h	DRC Bass Band Threshold2 Control 00'h: 0dB 01'h: -0.75dB 02'h: -1.5dB ... 1F'h: -45dB, with 0.75dB/step
Alc_bass_thmax	5:0	R/W	0'h	DRC Bass Band Threshold1 Control 00'h: 0dB 01'h: -0.375dB 02'h: -0.75dB ... 1F'h: -23.625dB, with 0.375dB/step

9.124. MX-F8h: Jack Detection Control

Default: 0000'h

Table 140. MX-F8h: Jack Detection Control

Name	Bits	Read/Write	Reset State	Description
reserved	15:8	R	0'h	Reserved
en_jd_combo_jack	7	R/W	0'h	Enable Jack Detect to Trigger Combo Jack 0'b: Disable 1'b: Enable
polarity_jd_tri_cbj	6	R/W	0'h	Select Jack Detect Polarity to Trigger Combo Jack 0'b: Low trigger 1'b: High trigger
Sel_jd_trigger_cbj	5:3	R/W	0'h	JD Trigger Source Selection for Combo Jack 000'b: From sta_gpio_jd1 001'b: From sta_jd1_1 010'b: From sta_jd1_2 011'b: From sta_jd2 100'b: Reserved 101'b: Reserved 110'b: From MX0B[12] Others: Reserved

Name	Bits	Read/Write	Reset State	Description
Sel_jd_trigger_hpo	2:0	R/W	0'h	JD Trigger Source Selection for HPO 000'b: From sta_gpio_jd1 001'b: From sta_jd1_1 010'b: From sta_jd1_2 011'b: From sta_jd2 100'b: Reserved 101'b: Reserved Others: Reserved

9.125. MX-F9h: Jack Detection Control

Default: 0000'h

Table 141. MX-F9h: Jack Detection Control

Name	Bits	Read/Write	Reset State	Description
reserved	15	R	0'h	Reserved
Sel_jd_trigger_spk	14:12	R/W	0'h	JD Trigger Source Selection for SPK_OUT 000'b: From sta_gpio_jd1 001'b: From sta_jd1_1 010'b: From sta_jd1_2 011'b: From sta_jd2 100'b: Reserved 101'b: Reserved Others: Reserved
Sel_jd_trigger_pdm	11:9	R/W	0'h	JD Trigger Source Selection for PDM 000'b: From sta_gpio_jd1 001'b: From sta_jd1_1 010'b: From sta_jd1_2 011'b: From sta_jd2 100'b: Reserved 101'b: Reserved Others: Reserved
Reserved	8:6	R	0'h	Reserved
Sel_jd_trigger_lout1	5:3	R/W	0'h	JD Trigger Source Selection for LOUT1 000'b: From sta_gpio_jd1 001'b: From sta_jd1_1 010'b: From sta_jd1_2 011'b: From sta_jd2 100'b: Reserved 101'b: Reserved Others: Reserved
Reserved	2:0	R/W	0'h	Reserved

9.126. MX-FAh: General Control 1

Default: 2060'h

Table 142. MX-FAh: General Control 1

Name	Bits	Read/Write	Reset State	Description
Reserved	15:1	R	0'h	Reserved
digital_gate_ctrl	0	R/W	0'h	Enable MCLK Gating Control 0'b: Disable 1'b: Enable

9.127. MX-FCh: General Control 2

Default: 0000'h

Table 143. MX-FCh: General Control 2

Name	Bits	Read/Write	Reset State	Description
Reserved	15:11	R/W	9'h	Reserved
En_detect_clk_sys	10:9	R/W	0'h	Enable MCLK Detection and Auto Switch AMP, EQ, Filter and RC CLK 00'b: Disable 01'b: When MCLK is removed, system clk will be switched to RC CLK a. MCLK off=> Class-D, Lout, HP and Mono amp off=>Reset Stereo ADC/DAC filter and ADC/DAC EQ=>Switch to RC CLK b. MCLK on=>Switch to MCLK=>Start Stereo ADC/DAC filter and ADC/DAC EQ => Class-D, Lout, HP and Mono amp on 10'b: When MCLK is removed, system clk will not be switched to RC CLK a. MCLK off=> Class-D, Lout, HP and Mono amp off=>Reset Stereo ADC/DAC filter and ADC/DAC EQ b. MCLK on=> Start Stereo ADC/DAC filter and ADC/DAC EQ => Class-D, Lout, HP and Mono amp on 11'b: Reserved
Reserved	8:0	R	0'h	Reserved

9.128. PR-3Dh: ADC/DAC RESET Control

Default: 2808'h

Table 144. PR-3Dh: ADC/DAC RESET Control

Name	Bits	Read/Write	Reset State	Description
Reserved	15:13	R/W	1'h	Reserved
En_ckgen_adc	12	R/W	0'h	Enable ADC Clock Generator 0'b: Disable 1'b: Enable
Reserved	11:10	R/W	2'h	Reserved
En_ckgen_dac	9	R/W	0'h	Enable DAC Clock Generator 0'b: Disable 1'b: Enable
Reserved	8:0	R/W	8'h	Reserved

9.129. PR-90h: HP Amplitude Threshold Control

Default: 3300'h

Table 145. PR-90h: HP Amplitude Threshold Control

Name	Bits	Read/Write	Reset State	Description
Mid_lv_hp_amp	15:0	R/W	3300'h	Middle Bound for Headphone Amp Detection

9.130. PR-91h: HP Amplitude Threshold Control

Default: 2200'h

Table 146. PR-91h: HP Amplitude Threshold Control

Name	Bits	Read/Write	Reset State	Description
low_lv_hp_amp	15:0	R/W	2200'h	Low Bound for Headphone Amp Detection

9.131. PR-A4h: DAC_L EQ (LPF:a1)

Default: 1C10'h

Table 147. PR-A4h: DAC_L EQ (LPF:a1)

Name	Bits	Read/Write	Reset State	Description
lpf_a1	15:0	R/W	1C10'h	2's complement in 3.13 format. (The range is from -4~3.99, the a1 should be in -2 ~ 1.99)

9.132. PR-A5h: DAC_L EQ (LPF:H0)

Default: 01F4'h

Table 148. PR-A5h: DAC_L EQ (LPF:H0)

Name	Bits	Read/Write	Reset State	Description
lpf_h0	15:0	R/W	01F4'h	2's complement in 3.13 format. (The range is from -4~3.99, the H0 should be in -4 ~ 3.99)

9.133. PR-A6h: DAC_R EQ (LPF:a1)

Default: 1C10'h

Table 149. PR-A6h: DAC_R EQ (LPF:a1)

Name	Bits	Read/Write	Reset State	Description
lpf_a1	15:0	R/W	1C10'h	2's complement in 3.13 format. (The range is from -4~3.99, the a1 should be in -2 ~ 1.99)

9.134. PR-A7h: DAC_R EQ (LPF:H0)

Default: 01F4'h

Table 150. PR-A7h: DAC_R EQ (LPF:H0)

Name	Bits	Read/Write	Reset State	Description
lpf_h0	15:0	R/W	01F4'h	2's complement in 3.13 format. (The range is from -4~3.99, the H0 should be in -4 ~ 3.99)

9.135. PR-AEh: DAC_L EQ (BPF2:a1)

Default: C882'h

Table 151. PR-AEh: DAC_L EQ (BPF2:a1)

Name	Bits	Read/Write	Reset State	Description
Bpf2_a1	15:0	R/W	C882'h	2's complement in 3.13 format. (The range is from -4~3.99, the a1 should be in -2 ~ 1.99)

9.136. PR-AFh: DAC_L EQ (BPF2:a2)

Default: 1C10'h

Table 152. PR-AFh: DAC_L EQ (BPF2:a2)

Name	Bits	Read/Write	Reset State	Description
Bpf2_a2	15:0	R/W	1C10'h	2's complement in 3.13 format. (The range is from -4~3.99, the a2 should be in -2 ~ 1.99)

9.137. PR-B0h: DAC_L EQ (BPF2:H0)

Default: 01F4'h

Table 153. PR-B0h: DAC_L EQ (BPF2:H0)

Name	Bits	Read/Write	Reset State	Description
Bpf2_h0	15:0	R/W	01F4'h	2's complement in 3.13 format. (The range is from -4~3.99, the H0 should be in -4 ~ 3.99)

9.138. PR-B1h: DAC_R EQ (BPF2:a1)

Default: C882'h

Table 154. PR-B1h: DAC_R EQ (BPF2:a1)

Name	Bits	Read/Write	Reset State	Description
Bpf2_a1	15:0	R/W	C882'h	2's complement in 3.13 format. (The range is from -4~3.99, the a1 should be in -2 ~ 1.99)

9.139. PR-B2h: DAC_R EQ (BPF2:a2)

Default: 1C10'h

Table 155. PR-B2h: DAC_R EQ (BPF2:a2)

Name	Bits	Read/Write	Reset State	Description
Bpf2_a2	15:0	R/W	1C10'h	2's complement in 3.13 format. (The range is from -4~3.99, the a2 should be in -2 ~ 1.99)

9.140. PR-B3h: DAC_R EQ (BPF2:H0)

Default: 01F4'h

Table 156. PR-B3h: DAC_R EQ (BPF2:H0)

Name	Bits	Read/Write	Reset State	Description
Bpf2_h0	15:0	R/W	01F4'h	2's complement in 3.13 format. (The range is from -4~3.99, the H0 should be in -4 ~ 3.99)

9.141. PR-B4h: DAC_L EQ (BPF3:a1)

Default: E904'h

Table 157. PR-B4h: DAC_L EQ (BPF3:a1)

Name	Bits	Read/Write	Reset State	Description
Bpf3_a1	15:0	R/W	E904'h	2's complement in 3.13 format. (The range is from -4~3.99, the a1 should be in -2 ~ 1.99)

9.142. PR-B5h: DAC_L EQ (BPF3:a2)

Default: 1C10'h

Table 158. PR-B5h: DAC_L EQ (BPF3:a2)

Name	Bits	Read/Write	Reset State	Description
Bpf3_a2	15:0	R/W	1C10'h	2's complement in 3.13 format. (The range is from -4~3.99, the a2 should be in -2 ~ 1.99)

9.143. PR-B6h: DAC_L EQ (BPF3:H0)

Default: 01F4'h

Table 159. PR-B6h: DAC_L EQ (BPF3:H0)

Name	Bits	Read/Write	Reset State	Description
Bpf3_h0	15:0	R/W	01F4'h	2's complement in 3.13 format. (The range is from -4~3.99, the H0 should be in -4 ~ 3.99)

9.144. PR-B7h: DAC_R EQ (BPF3:a1)

Default: E904'h

Table 160. PR-B7h: DAC_R EQ (BPF3:a1)

Name	Bits	Read/Write	Reset State	Description
Bpf3_a1	15:0	R/W	E904'h	2's complement in 3.13 format. (The range is from -4~3.99, the a1 should be in -2 ~ 1.99)

9.145. PR-B8h: DAC_R EQ (BPF3:a2)

Default: 1C10'h

Table 161. PR-B8h: DAC_R EQ (BPF3:a2)

Name	Bits	Read/Write	Reset State	Description
Bpf3_a2	15:0	R/W	1C10'h	2's complement in 3.13 format. (The range is from -4~3.99, the a2 should be in -2 ~ 1.99)

9.146. PR-B9h: DAC_R EQ (BPF3:H0)

Default: 01F4'h

Table 162. PR-B9h: DAC_R EQ (BPF3:H0)

Name	Bits	Read/Write	Reset State	Description
Bpf3_h0	15:0	R/W	01F4'h	2's complement in 3.13 format. (The range is from -4~3.99, the H0 should be in -4 ~ 3.99)

9.147. PR-BAh: DAC_L EQ (BPF4:a1)

Default: E904'h

Table 163. PR-BAh: DAC_L EQ (BPF4:a1)

Name	Bits	Read/Write	Reset State	Description
Bpf4_a1	15:0	R/W	E904'h	2's complement in 3.13 format. (The range is from -4~3.99, the a1 should be in -2 ~ 1.99)

9.148. PR-BBh: DAC_L EQ (BPF4:a2)

Default: 1C10'h

Table 164. PR-BBh: DAC_L EQ (BPF4:a2)

Name	Bits	Read/Write	Reset State	Description
Bpf4_a2	15:0	R/W	1C10'h	2's complement in 3.13 format. (The range is from -4~3.99, the a2 should be in -2 ~ 1.99)

9.149. PR-BCh: DAC_L EQ (BPF4:H0)

Default: 01F4'h

Table 165. PR-BCh: DAC_L EQ (BPF4:H0)

Name	Bits	Read/Write	Reset State	Description
Bpf4_h0	15:0	R/W	01F4'h	2's complement in 3.13 format. (The range is from -4~3.99, the H0 should be in -4 ~ 3.99)

9.150. PR-BDh: DAC_R EQ (BPF4:a1)

Default: E904'h

Table 166. PR-BDh: DAC_R EQ (BPF4:a1)

Name	Bits	Read/Write	Reset State	Description
Bpf4_a1	15:0	R/W	E904'h	2's complement in 3.13 format. (The range is from -4~3.99, the a1 should be in -2 ~ 1.99)

9.151. PR-BEh: DAC_R EQ (BPF4:a2)

Default: 1C10'h

Table 167. PR-BEh: DAC_R EQ (BPF4:a2)

Name	Bits	Read/Write	Reset State	Description
Bpf4_a2	15:0	R/W	1C10'h	2's complement in 3.13 format. (The range is from -4~3.99, the a2 should be in -2 ~ 1.99)

9.152. PR-BFh: DAC_R EQ (BPF4:H0)

Default: 01F4'h

Table 168. PR-BFh: DAC_R EQ (BPF4:H0)

Name	Bits	Read/Write	Reset State	Description
Bpf4_h0	15:0	R/W	01F4'h	2's complement in 3.13 format. (The range is from -4~3.99, the H0 should be in -4 ~ 3.99)

9.153. PR-C0h: DAC_L EQ (HPF1:a1)

Default: 1C10'h

Table 169. PR-C0h: DAC_L EQ (HPF1:a1)

Name	Bits	Read/Write	Reset State	Description
Hpf1_a1	15:0	R/W	1C10'h	2's complement in 3.13 format. (The range is from -4~3.99, the a1 should be in -2 ~ 1.99)

9.154. PR-C1h: DAC_L EQ (HPF1:H0)

Default: 01F4'h

Table 170. PR-C1h: DAC_L EQ (HPF1:H0)

Name	Bits	Read/Write	Reset State	Description
Hpf1_h0	15:0	R/W	01F4'h	2's complement in 3.13 format. (The range is from -4~3.99, the H0 should be in -4 ~ 3.99)

9.155. PR-C2h: DAC_R EQ (HPF1:a1)

Default: 1C10'h

Table 171. PR-C2h: DAC_R EQ (HPF1:a1)

Name	Bits	Read/Write	Reset State	Description
Hpf1_a1	15:0	R/W	1C10'h	2's complement in 3.13 format. (The range is from -4~3.99, the a1 should be in -2 ~ 1.99)

9.156. PR-C3h: DAC_R EQ (HPF1:H0)

Default: 01F4'h

Table 172. PR-C3h: DAC_R EQ (HPF1:H0)

Name	Bits	Read/Write	Reset State	Description
Hpf1_h0	15:0	R/W	01F4'h	2's complement in 3.13 format. (The range is from -4~3.99, the H0 should be in -4 ~ 3.99)

9.157. PR-C4h: DAC_L EQ (HPF2:a1)

Default: 2000'h

Table 173. PR-C4h: DAC_L EQ (HPF2:a1)

Name	Bits	Read/Write	Reset State	Description
Hpf2_a1	15:0	R/W	2000'h	2's complement in 3.13 format. (The range is from -4~3.99, the a1 should be in -2 ~ 1.99)

9.158. PR-C5h: DAC_L EQ (HPF2:a2)

Default: 0000'h

Table 174. PR-C5h: DAC_L EQ (HPF2:a2)

Name	Bits	Read/Write	Reset State	Description
Hpf2_a2	15:0	R/W	0000'h	2's complement in 3.13 format. (The range is from -4~3.99, the a2 should be in -2 ~ 1.99)

9.159. PR-C6h: DAC_L EQ (HPF2:H0)

Default: 1FF1'h

Table 175. PR-C6h: DAC_L EQ (HPF2:H0)

Name	Bits	Read/Write	Reset State	Description
Hpf2_h0	15:0	R/W	1FF1'h	2's complement in 3.13 format. (The range is from -4~3.99, the H0 should be in -4 ~ 3.99)

9.160. PR-C7h: DAC_R EQ (HPF2:a1)

Default: 2000'h

Table 176. PR-C7h: DAC_R EQ (HPF2:a1)

Name	Bits	Read/Write	Reset State	Description
Hpf2_a1	15:0	R/W	2000'h	2's complement in 3.13 format. (The range is from -4~3.99, the a1 should be in -2 ~ 1.99)

9.161. PR-C8h: DAC_R EQ (HPF2:a2)

Default: 0000'h

Table 177. PR-C8h: DAC_R EQ (HPF2:a2)

Name	Bits	Read/Write	Reset State	Description
Hpf2_a2	15:0	R/W	0000'h	2's complement in 3.13 format. (The range is from -4~3.99, the a2 should be in -2 ~ 1.99)

9.162. PR-C9h: DAC_R EQ (HPF2:H0)

Default: 1FF1'h

Table 178. PR-C9h: DAC_R EQ (HPF2:H0)

Name	Bits	Read/Write	Reset State	Description
Hpf2_h0	15:0	R/W	1FF1'h	2's complement in 3.13 format. (The range is from -4~3.99, the H0 should be in -4 ~ 3.99)

9.163. PR-CAh: DAC_L EQ Pre-Volume Control

Default: 0800'h

Table 179. PR-CAh: DAC_L EQ Pre-Volume Control

Name	Bits	Read/Write	Reset State	Description
Da_eq_pre_vol_l	15:0	R/W	0800'h	DAC Left Channel EQ Pre-Volume Control 2's Complement in 5.11 Format. (Default is 0dB) The range is from -16 ~ 15.99, pre-gain should be in 0 ~ 15.99 [+24dB ~ -66dB]

9.164. PR-CBh: DAC_R EQ Pre-Volume Control

Default: 0800'h

Table 180. PR-CBh: DAC_R EQ Pre-Volume Control

Name	Bits	Read/Write	Reset State	Description
Da_eq_pre_vol_l	15:0	R/W	0800'h	DAC Right Channel EQ Pre-Volume Control 2's Complement in 5.11 Format. (Default is 0dB) The range is from -16 ~ 15.99, pre-gain should be in 0 ~ 15.99 [+24dB ~ -66dB]

9.165. PR-CCh: DAC_L EQ Post-Volume Control

Default: 0800'h

Table 181. PR-CCh: DAC_L EQ Post-Volume Control

Name	Bits	Read/Write	Reset State	Description
Da_eq_post_vol_l	15:0	R/W	0800'h	DAC Left Channel EQ Post-Volume Control 2's Complement in 5.11 Format. (Default is 0dB) The range is from -16 ~ 15.99, pre-gain should be in 0 ~ 15.99 [+24dB ~ -66dB]

9.166. PR-CDh: DAC_R EQ Post-Volume Control

Default: 0800'h

Table 182. PR-CDh: DAC R EQ Post-Volume Control

Name	Bits	Read/Write	Reset State	Description
Da_eq_post_vol_l	15:0	R/W	0800'h	DAC Right Channel EQ Post-Volume Control 2's Complement in 5.11 Format. (Default is 0dB) The range is from -16 ~ 15.99, pre-gain should be in 0 ~ 15.99 [+24dB ~ -66dB]

9.167. PR-CEh: ADC EQ (LPF:a1)

Default: 1C10'h

Table 183. PR-CEh: ADC EQ (LPF:a1)

Name	Bits	Read/Write	Reset State	Description
ad_eq_lpf_a1	15:0	R/W	1C10'h	2's complement in 3.13 format. (The range is from -4~3.99, the a1 should be in -2 ~ 1.99)

9.168. PR-CFh: ADC EQ (LPF:H0)

Default: 01F4'h

Table 184. PR-CFh: ADC EQ (LPF:H0)

Name	Bits	Read/Write	Reset State	Description
ad_eq_lpf_h0	15:0	R/W	01F4'h	2's complement in 3.13 format. (The range is from -4~3.99, the H0 should be in -4 ~ 3.99)

9.169. PR-D0h: ADC EQ (BPF1:a1)

Default: E904'h

Table 185. PR-D0h: ADC EQ (BPF1:a1)

Name	Bits	Read/Write	Reset State	Description
ad_eq_Bpf1_a1	15:0	R/W	E904'h	2's complement in 3.13 format. (The range is from -4~3.99, the a1 should be in -2 ~ 1.99)

9.170. PR-D1h: ADC EQ (BPF1:a2)

Default: 1C10'h

Table 186. PR-D1h: ADC EQ (BPF1:a2)

Name	Bits	Read/Write	Reset State	Description
Ad_eq_Bpf1_a2	15:0	R/W	1C10'h	2's complement in 3.13 format. (The range is from -4~3.99, the a2 should be in -2 ~ 1.99)

9.171. PR-D2h: ADC EQ (BPF1:H0)

Default: 01F4'h

Table 187. PR-D2h: ADC EQ (BPF1:H0)

Name	Bits	Read/Write	Reset State	Description
ad_eq_Bpf1_h0	15:0	R/W	01F4'h	2's complement in 3.13 format. (The range is from -4~3.99, the H0 should be in -4 ~ 3.99)

9.172. PR-D3h: ADC EQ (BPF2:a1)

Default: E904'h

Table 188. PR-D3h: ADC EQ (BPF2:a1)

Name	Bits	Read/Write	Reset State	Description
ad_eq_Bpf2_a1	15:0	R/W	E904'h	2's complement in 3.13 format. (The range is from -4~3.99, the a1 should be in -2 ~ 1.99)

9.173. PR-D4h: ADC EQ (BPF2:a2)

Default: 1C10'h

Table 189. PR-D4h: ADC EQ (BPF2:a2)

Name	Bits	Read/Write	Reset State	Description
Ad_eq_Bpf2_a2	15:0	R/W	1C10'h	2's complement in 3.13 format. (The range is from -4~3.99, the a2 should be in -2 ~ 1.99)

9.174. PR-D5h: ADC EQ (BPF2:H0)

Default: 01F4'h

Table 190. PR-D5h: ADC EQ (BPF2:H0)

Name	Bits	Read/Write	Reset State	Description
ad_eq_Bpf2_h0	15:0	R/W	01F4'h	2's complement in 3.13 format. (The range is from -4~3.99, the H0 should be in -4 ~ 3.99)

9.175. PR-D6h: ADC EQ (BPF3:a1)

Default: E904'h

Table 191. PR-D6h: ADC EQ (BPF3:a1)

Name	Bits	Read/Write	Reset State	Description
ad_eq_Bpf3_a1	15:0	R/W	E904'h	2's complement in 3.13 format. (The range is from -4~3.99, the a1 should be in -2 ~ 1.99)

9.176. PR-D7h: ADC EQ (BPF3:a2)

Default: 1C10'h

Table 192. PR-D7h: ADC EQ (BPF3:a2)

Name	Bits	Read/Write	Reset State	Description
Ad_eq_Bpf3_a2	15:0	R/W	1C10'h	2's complement in 3.13 format. (The range is from -4~3.99, the a2 should be in -2 ~ 1.99)

9.177. PR-D8h: ADC EQ (BPF3:H0)

Default: 01F4'h

Table 193. PR-D8h: ADC EQ (BPF3:H0)

Name	Bits	Read/Write	Reset State	Description
ad_eq_Bpf3_h0	15:0	R/W	01F4'h	2's complement in 3.13 format. (The range is from -4~3.99, the H0 should be in -4 ~ 3.99)

9.178. PR-D9h: ADC EQ (BPF4:a1)

Default: E904'h

Table 194. PR-D9h: ADC EQ (BPF4:a1)

Name	Bits	Read/Write	Reset State	Description
ad_eq_Bpf4_a1	15:0	R/W	E904'h	2's complement in 3.13 format. (The range is from -4~3.99, the a1 should be in -2 ~ 1.99)

9.179. PR-DAh: ADC EQ (BPF4:a2)

Default: 1C10'h

Table 195. PR-DAh: ADC EQ (BPF4:a2)

Name	Bits	Read/Write	Reset State	Description
Ad_eq_Bpf4_a2	15:0	R/W	1C10'h	2's complement in 3.13 format. (The range is from -4~3.99, the a2 should be in -2 ~ 1.99)

9.180. PR-DBh: ADC EQ (BPF4:H0)

Default: 01F4'h

Table 196. PR-DBh: ADC EQ (BPF4:H0)

Name	Bits	Read/Write	Reset State	Description
ad_eq_Bpf4_h0	15:0	R/W	01F4'h	2's complement in 3.13 format. (The range is from -4~3.99, the H0 should be in -4 ~ 3.99)

9.181. PR-DCh: ADC EQ (HPF1:a1)

Default: 1C10'h

Table 197. PR-DCh: ADC EQ (HPF1:a1)

Name	Bits	Read/Write	Reset State	Description
Ad_eq_hp1_a1	15:0	R/W	1C10'h	2's complement in 3.13 format. (The range is from -4~3.99, the a1 should be in -2 ~ 1.99)

9.182. PR-DDh: ADC EQ (HPF1:H0)

Default: 01F4'h

Table 198. PR-DDh: ADC EQ (HPF1:H0)

Name	Bits	Read/Write	Reset State	Description
ad_eq_hpfl_h0	15:0	R/W	01F4'h	2's complement in 3.13 format. (The range is from -4~3.99, the H0 should be in -4 ~ 3.99)

9.183. PR-E1h: ADC EQ Pre-Volume Control

Default: 0800'h

Table 199. PR-E1h: ADC EQ Pre-Volume Control

Name	Bits	Read/Write	Reset State	Description
ad_eq_pre_vol	15:0	R/W	0800'h	ADC Left Channel EQ Pre-Volume Control 2's Complement in 5.11 Format. (Default is 0dB) The range is from -16 ~ 15.99, pre-gain should be in 0 ~ 15.99 [+24dB ~ -66dB]

9.184. PR-E2h: ADC EQ Post-Volume Control

Default: 0800'h

Table 200. PR-E2h: ADC EQ Post-Volume Control

Name	Bits	Read/Write	Reset State	Description
Ad_eq_post_vol	15:0	R/W	0800'h	ADC Left Channel EQ Post-Volume Control 2's Complement in 5.11 Format. (Default is 0dB) The range is from -16 ~ 15.99, pre-gain should be in 0 ~ 15.99 [+24dB ~ -66dB]

9.185. PR-E5h: DAC_L Biquad EQ (BPF1:h0-1)

Default: 0000'h

Table 201. PR-E5h: DAC_L Biquad EQ (BPF1:h0-1)

Name	Bits	Read/Write	Reset State	Description
Reserved	15:13	R	0'h	Reserved
Eq_biquad_h0_1_msb	12:0	R/W	0'h	2's complement in 4.25 format. (The range is from -8~7.99)

9.186. PR-E6h: DAC_L Biquad EQ (BPF1:h0-2)

Default: 0000'h

Table 202. PR-E6h: DAC_L Biquad EQ (BPF1:h0-2)

Name	Bits	Read/Write	Reset State	Description
Eq_biquad_h0_l_lsb	15:0	R/W	0'h	2's complement in 4.25 format. (The range is from -8~7.99)

9.187. PR-E7h: DAC_L Biquad EQ (BPF1:b1-1)

Default: 0000'h

Table 203. PR-E7h: DAC_L Biquad EQ (BPF1:b1-1)

Name	Bits	Read/Write	Reset State	Description
Reserved	15:13	R	0'h	Reserved
Eq_biquad_b1_l_msb	12:0	R/W	0'h	2's complement in 4.25 format. (The range is from -8~7.99)

9.188. PR-E8h: DAC_L Biquad EQ (BPF1:b1-2)

Default: 0000'h

Table 204. PR-E8h: DAC_L Biquad EQ (BPF1:b1-2)

Name	Bits	Read/Write	Reset State	Description
Eq_biquad_b1_l_lsb	15:0	R/W	0'h	2's complement in 4.25 format. (The range is from -8~7.99)

9.189. PR-E9h: DAC_L Biquad EQ (BPF1:b2-1)

Default: 0000'h

Table 205. PR-E9h: DAC_L Biquad EQ (BPF1:b2-1)

Name	Bits	Read/Write	Reset State	Description
Reserved	15:13	R	0'h	Reserved
Eq_biquad_b2_l_msb	12:0	R/W	0'h	2's complement in 4.25 format. (The range is from -8~7.99)

9.190. PR-EAh: DAC_L Biquad EQ (BPF1:b2-2)

Default: 0000'h

Table 206. PR-EAh: DAC_L Biquad EQ (BPF1:b2-2)

Name	Bits	Read/Write	Reset State	Description
Eq_biquad_b2_1_lsb	15:0	R/W	0'h	2's complement in 4.25 format. (The range is from -8~7.99)

9.191. PR-EBh: DAC_L Biquad EQ (BPF1:a1-1)

Default: 0000'h

Table 207. PR-EBh: DAC_L Biquad EQ (BPF1:a1-1)

Name	Bits	Read/Write	Reset State	Description
Reserved	15:13	R	0'h	Reserved
Eq_biquad_a1_1_msb	12:0	R/W	0'h	2's complement in 4.25 format. (The range is from -8~7.99)

9.192. PR-ECh: DAC_L Biquad EQ (BPF1:a1-2)

Default: 0000'h

Table 208. PR-ECh: DAC_L Biquad EQ (BPF1:a1-2)

Name	Bits	Read/Write	Reset State	Description
Eq_biquad_a1_1_lsb	15:0	R/W	0'h	2's complement in 4.25 format. (The range is from -8~7.99)

9.193. PR-EDh: DAC_L Biquad EQ (BPF1:a2-1)

Default: 0000'h

Table 209. PR-EDh: DAC_L Biquad EQ (BPF1:a2-1)

Name	Bits	Read/Write	Reset State	Description
Reserved	15:13	R	0'h	Reserved
Eq_biquad_a2_1_msb	12:0	R/W	0'h	2's complement in 4.25 format. (The range is from -8~7.99)

9.194. PR-EEh: DAC_L Biquad EQ (BPF1:a2-2)

Default: 0000'h

Table 210. PR-EEh: DAC_L Biquad EQ (BPF1:a2-2)

Name	Bits	Read/Write	Reset State	Description
Eq_biquad_a2_l_lsb	15:0	R/W	0'h	2's complement in 4.25 format. (The range is from -8~7.99)

9.195. PR-EFh: DAC_R Biquad EQ (BPF1:h0-1)

Default: 0000'h

Table 211. PR-EFh: DAC_R Biquad EQ (BPF1:h0-1)

Name	Bits	Read/Write	Reset State	Description
Reserved	15:13	R	0'h	Reserved
Eq_biquad_h0_r_msb	12:0	R/W	0'h	2's complement in 4.25 format. (The range is from -8~7.99)

9.196. PR-F0h: DAC_R Biquad EQ (BPF1:h0-2)

Default: 0000'h

Table 212. PR-F0h: DAC_R Biquad EQ (BPF1:h0-2)

Name	Bits	Read/Write	Reset State	Description
Eq_biquad_h0_r_lsb	15:0	R/W	0'h	2's complement in 4.25 format. (The range is from -8~7.99)

9.197. PR-F1h: DAC_R Biquad EQ (BPF1:b1-1)

Default: 0000'h

Table 213. PR-F1h: DAC_R Biquad EQ (BPF1:b1-1)

Name	Bits	Read/Write	Reset State	Description
Reserved	15:13	R	0'h	Reserved
Eq_biquad_b1_r_msb	12:0	R/W	0'h	2's complement in 4.25 format. (The range is from -8~7.99)

9.198. PR-F2h: DAC_R Biquad EQ (BPF1:b1-2)

Default: 0000'h

Table 214. PR-F2h: DAC_R Biquad EQ (BPF1:b1-2)

Name	Bits	Read/Write	Reset State	Description
Eq_biquad_b1_r_lsb	15:0	R/W	0'h	2's complement in 4.25 format. (The range is from -8~7.99)

9.199. PR-F3h: DAC_R Biquad EQ (BPF1:b2-1)

Default: 0000'h

Table 215. PR-F3h: DAC_R Biquad EQ (BPF1:b2-1)

Name	Bits	Read/Write	Reset State	Description
Reserved	15:13	R	0'h	Reserved
Eq_biquad_b2_r_msb	12:0	R/W	0'h	2's complement in 4.25 format. (The range is from -8~7.99)

9.200. PR-F4h: DAC_R Biquad EQ (BPF1:b2-2)

Default: 0000'h

Table 216. PR-F4h: DAC_R Biquad EQ (BPF1:b2-2)

Name	Bits	Read/Write	Reset State	Description
Eq_biquad_b2_r_lsb	15:0	R/W	0'h	2's complement in 4.25 format. (The range is from -8~7.99)

9.201. PR-F5h: DAC_R Biquad EQ (BPF1:a1-1)

Default: 0000'h

Table 217. PR-F5h: DAC_R Biquad EQ (BPF1:a1-1)

Name	Bits	Read/Write	Reset State	Description
Reserved	15:13	R	0'h	Reserved
Eq_biquad_a1_r_msb	12:0	R/W	0'h	2's complement in 4.25 format. (The range is from -8~7.99)

9.202. PR-F6h: DAC_R Biquad EQ (BPF1:a1-2)

Default: 0000'h

Table 218. PR-F6h: DAC_R Biquad EQ (BPF1:a1-2)

Name	Bits	Read/Write	Reset State	Description
Eq_biquad_a1_r_lsb	15:0	R/W	0'h	2's complement in 4.25 format. (The range is from -8~7.99)

9.203. PR-F7h: DAC_R Biquad EQ (BPF1:a2-1)

Default: 0000'h

Table 219. PR-F7h: DAC_R Biquad EQ (BPF1:a2-1)

Name	Bits	Read/Write	Reset State	Description
Reserved	15:13	R	0'h	Reserved
Eq_biquad_a2_r_msb	12:0	R/W	0'h	2's complement in 4.25 format. (The range is from -8~7.99)

9.204. PR-F8h: DAC_R Biquad EQ (BPF1:a2-2)

Default: 0000'h

Table 220. PR-F8h: DAC_R Biquad EQ (BPF1:a2-2)

Name	Bits	Read/Write	Reset State	Description
Eq_biquad_a2_r_lsb	15:0	R/W	0'h	2's complement in 4.25 format. (The range is from -8~7.99)

9.205. MX-FEh: Vendor ID

Default: 10EC'h

Table 221. MX-FEh: Vendor ID

Name	Bits	Read/Write	Reset State	Description
Vendor_id	15:0	R	10EC'h	Vendor ID

10. Electrical Characteristics

10.1. DC Characteristics

10.1.1. Absolute Maximum Ratings

Table 222. Absolute Maximum Ratings

Parameter	Symbol	Min	Typ	Max	Units
Power Supplies					
Digital IO Buffer	DBVDD	-0.3	-	3.63	V
Digital Core	DCVDD	-0.3	-	1.4	V
Analog	AVDD	-0.3	-	1.98	V
Analog	DACREF	-0.3	-	1.98	V
Headphone	CPVDD	-0.3	-	1.98	V
Micbias	MICVDD	-0.3	-	3.63	V
Speaker	SPKVDD	-0.3	-	7 ¹	V
Operating Ambient Temperature	Ta	-25	-	+85	°C
Storage Temperature	Ts	-55	-	+125	°C

Note 1: SPKVDD=5V with 3.5% duty cycle Power bouncing up to SPKVDD=7V is acceptable.

10.1.2. Recommended Operating Conditions

Table 223. Recommended Operating Conditions

Parameter	Symbol	Min	Typ	Max	Units
Digital IO Buffer	DBVDD	1.71	1.8	3.6	V
Digital Core	DCVDD	1.05	1.2	1.3	V
Analog	AVDD	1.71	1.8	1.9	V
Analog	DACREF	1.71	1.8	1.9	V
Headphone	CPVDD	1.71	1.8	1.9	V
Micbias	MICVDD	3.0	3.3	3.6	V
Speaker	SPKVDD ¹	3.0	3.6/5.0	5.5	V

Note 1: A 10 μ F Capacitor must be connected from SPKVDD to SPKGND, and should be placed as close as possible to the SPKVDD pin.

10.1.3. Static Characteristics

Table 224. Static Characteristics

Parameter	Symbol	Min	Typ	Max	Units
Input Voltage Range	V _{IN}	-0.30	-	DBVDD+0.30	V
Low Level Input Voltage	V _{IL}	-	-	0.35DBVDD	V
High Level Input Voltage	V _{IH}	0.65DBVDD	-	-	V
High Level Output Voltage	V _{OH}	0.9DBVDD	-	-	V
Low Level Output Voltage	V _{OL}	-	-	0.1DBVDD	V
Output Buffer High Drive Current	-	0.6	1.8	4.3	mA
Output Buffer Low Drive Current	-	0.7	2.1	4.8	mA

Parameter	Symbol	Min	Typ	Max	Units
Input Buffer Pull-Up Resistor	-	55	110	270	K Ω
Input Buffer Pull-Down Resistor	-	63	130	300	K Ω

Note: DBVDD=1.8V, DCVDD=1.2V, T_{ambient}=40°C.

10.2. Analog Performance Characteristics

Table 225. Analog Performance Characteristics

Parameter	Min	Typ	Max	Units
Full Scale Input Voltage				
Line Inputs (Single-ended)	-	0.6	-	Vrms
MIC Inputs (Single-ended)	-	0.6	-	Vrms
MIC Inputs (Differential)	-	1.2	-	Vrms
Full Scale Output Voltage				
Line Outputs (Single-ended)	-	1.0	-	Vrms
Line Outputs (Differential)	-	1.0	-	Vrms
Headphone Amplifiers Outputs (For 10KOhm Load)	-	1.0	-	Vrms
Headphone Amplifiers Outputs (For 16Ohm Load)	-	0.7	-	Vrms
Headphone Amplifiers Outputs (For 32Ohm Load)	-	0.9	-	Vrms
Speaker Amplifiers Outputs (SPKVDD=5.0V with 4 Ω Load, 1% THD+N)	-	2.9	-	Vrms
S/N Ratio				
Stereo DAC Direct to HP_L/R with 16/32/10KOhm	-	100	102	dBA
Stereo DAC Direct to SPK_OUT with 80hm/5V (Differential)	-	94		dBA
Line_In to Stereo ADC with 0dB (Single-end)		94	95	dBA
MIC_In to Stereo ADC with 0dB (Differential or Single-end)		94	95	dBA
MIC_In to Stereo ADC with 20dB and MICBIAS (Differential or Single-end)		89		dBA
MIC_In to Stereo ADC with 40dB and MICBIAS (Differential or Single-end)		78		dBA
MIC_In to Stereo ADC with 50dB and MICBIAS (Differential or Single-end)		68		dBA
Total Harmonic Distortion + Noise				
DAC Direct to HP_L/R with 16Ohm				
Po = 20mW/CH (16Ohm) (with AES17 Filter)		-81	-83	dB
Po = 20mW/CH (32Ohm) (with AES17 Filter)		-81	-83	dB
DAC Direct to HP_L/R with 10KOhm -3dBFS		-85		dB
DAC Direct to SPK_OUT (Differential)				
Po=1.2W (5V/80hm)		<1		%
Po=2.1W (5V/40hm)		<1		%
Po=920mW (4.2V/80hm)		<1		%
Po=650mW (3.6V/80hm)		<1		%

Parameter	Min	Typ	Max	Units
Line_In to Stereo ADC with 0dB (Single-end)		-83		dB
MIC_In to Stereo ADC with 0dB (Differential or Single-end)		-83		dB
MIC_In to Stereo ADC with 20dB and MICBIAS (Differential or Single-end)		-81		dB
MIC_In to Stereo ADC with 40dB and MICBIAS (Differential or Single-end)		-74		dB
MIC_In to Stereo ADC with 50dB and MICBIAS (Differential or Single-end)		-65		dB
BTL Speaker Amplifier Efficiency (f_{IN} =1kHz, 8Ω Load, SPKVDD=5.0V, Output Power=1.5W, with LC filter, L=33uH and C=1uF) Class-D (Stereo Mode)	-	88	-	%
Power Consumption (Slave I2S Mode, 16-bit, SR: 44.1KHz) P_power down (No Clock Input)		<100		uW
P_playback (Stereo DAC to HP_OUT with 16 Ohm Load, With Clock, play silence)		<= 6		mW
P_playback (Stereo DAC to HP_OUT with 16 Ohm Load, With Clock, Po=1mW/CH)		<= 13		mW
P_record (LINE_IN to Stereo ADC, With Clock)		< 9		mW
Power Down Current I _{DDA} (Analog Block)	-	-	10	μA
I _{DD} (Digital Block)	-	-	20	μA
MICBIAS1/2 Output Voltage Setting 1	-	2.7	-	V
Setting 2	-	1.8	-	V
MICBIAS1/2 Drive Current MICBIAS = 0.9*LDO2_O	-	4	-	mA

Note: Standard test conditions:

T_{ambient}=25°C

DBVDD=1.8V

AVDD=1.8V

MICVDD=3.3V

CPVDD=1.8V

SPKVDD=5.0V or 4.2V or 3.6V.

1kHz input sine wave; PCM Sampling frequency=48kHz; Test bench Characterization BW: 10Hz~22kHz, 0dB attenuation
dBA: with A-Weighting

10.3. Signal Timing

10.3.1. I²C Control Interface

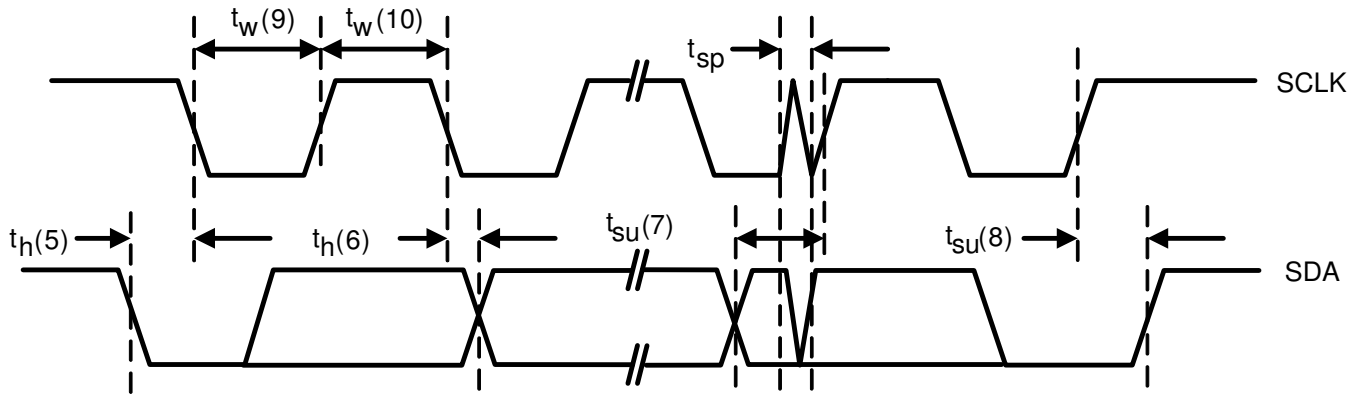


Figure 32. I²C Control Interface

Table 226. I²C Timing

Parameter	Symbol	Min	Typ	Max	Units
Clock Pulse Duration	$t_w(9)$	1.3	-	-	μ s
Clock Pulse Duration	$t_w(10)$	600	-	-	ns
Clock Frequency	F	0	-	400K	Hz
Start Hold Time	$t_h(5)$	600	-	-	ns
Data Setup Time	$t_{su}(7)$	100	-	-	ns
Data Hold Time	$t_h(6)$	-	-	900	ns
Rising Time	t_r	-	-	300	ns
Falling Time	t_f	-	-	300	ns
Stop Setup Time	$t_{su}(8)$	600	-	-	ns
Pulse Width of Spikes Suppressed Input Filter	t_{sp}	0	-	50	ns

10.3.2. I²S/PCM Interface Master Mode

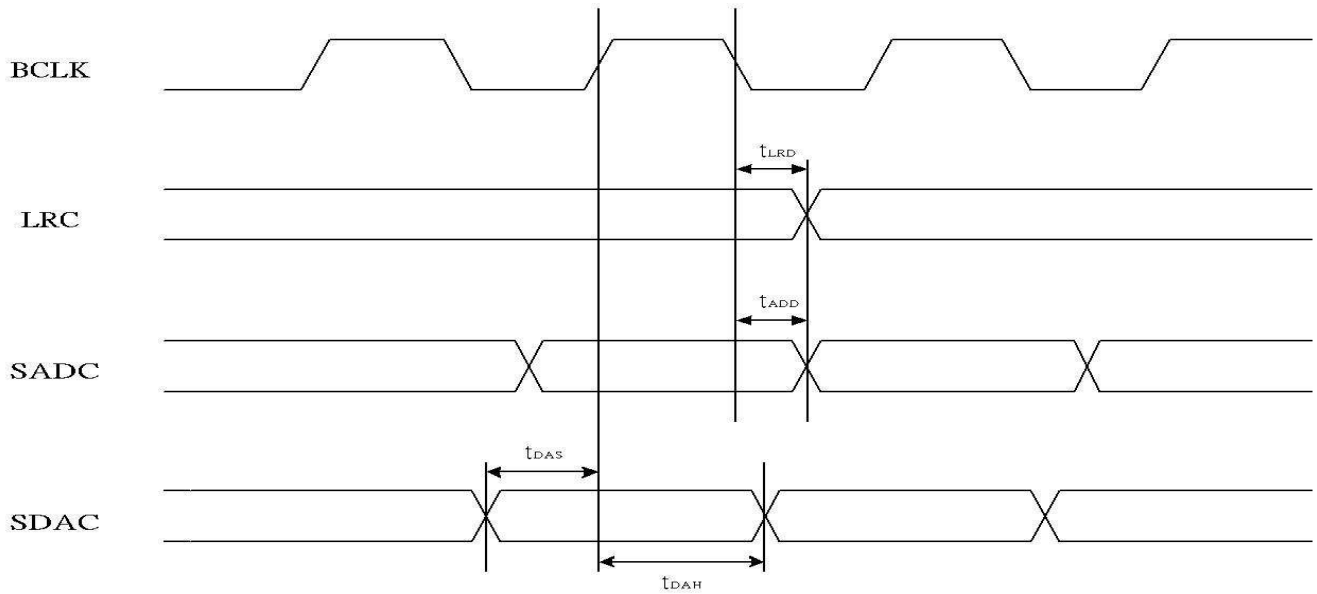


Figure 33. Timing of I²S/PCM Master Mode

Table 227. Timing of I²S/PCM Master Mode

Parameter	Symbol	Min	Typ	Max	Units
LRCK Output to BCLK Delay	t_{LRD}	-	-	30	ns
Data Output to BCLK Delay	t_{ADD}	-	-	30	ns
Data Input Setup Time	t_{DAS}	10	-	-	ns
Data Input Hold Time	t_{DAH}	10	-	-	ns

10.3.3. I²S/PCM Interface Slave Mode

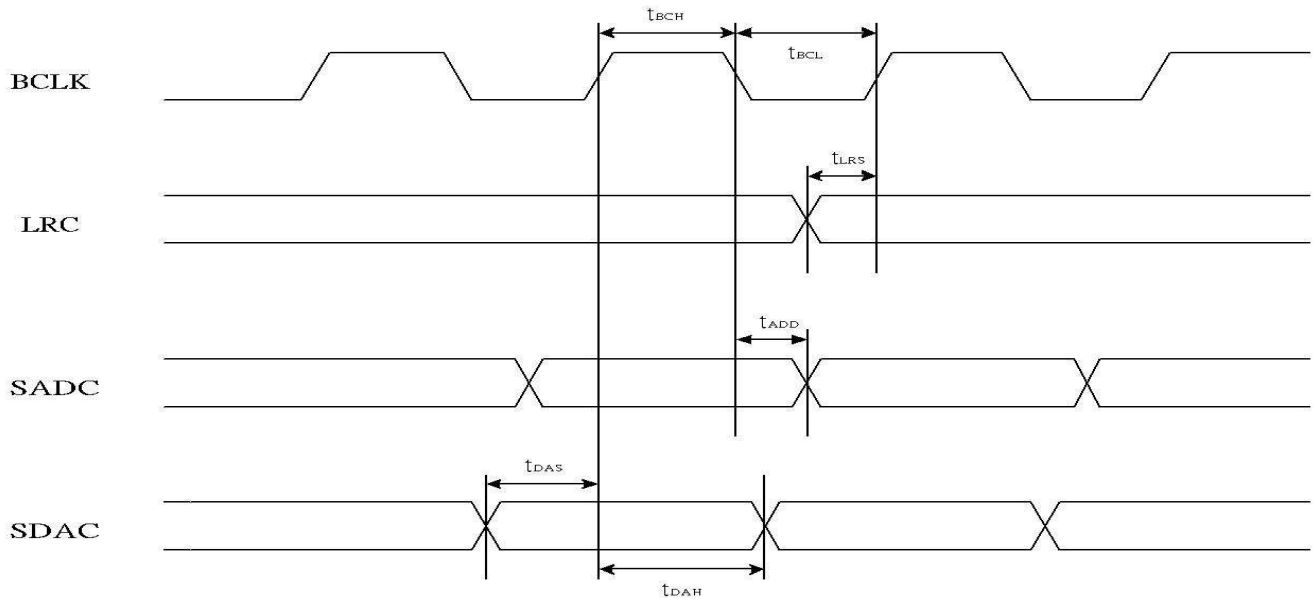


Figure 34. I²S/PCM Slave Mode Timing

Table 228. I²S/PCM Slave Mode Timing

Parameter	Symbol	Min	Typ	Max	Units
BCLK High Pulse Width	t_{BCH}	20	-	-	ns
BCLK Low Pulse Width	t_{BCL}	20	-	-	ns
LRCK Input Setup Time	t_{LRS}	30	-	-	ns
Data Output to BCLK Delay	t_{ADD}	-	-	30	ns
Data Input Setup Time	t_{DAS}	10	-	-	ns
Data Input Hold Time	t_{DAH}	10	-	-	ns

10.3.4. Digital Microphone Interface

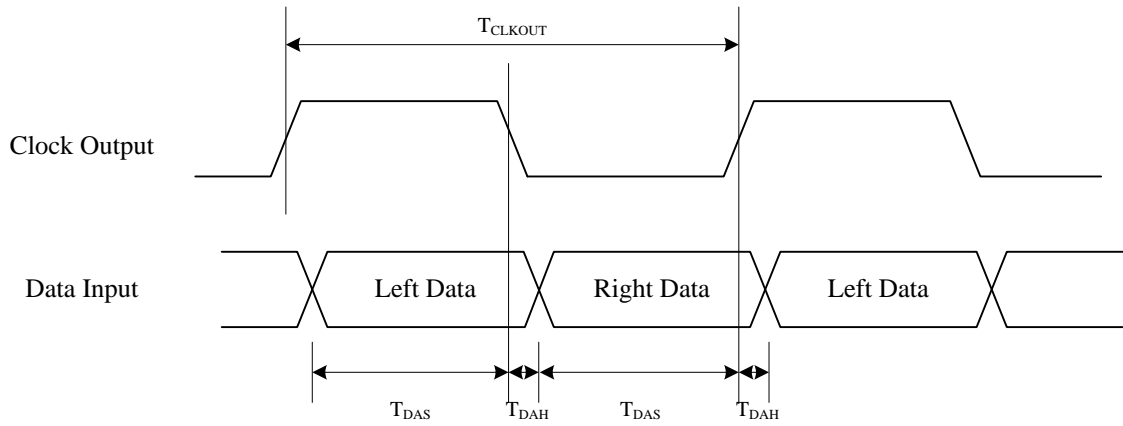
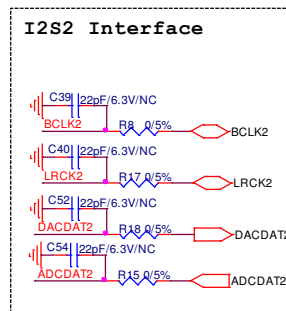
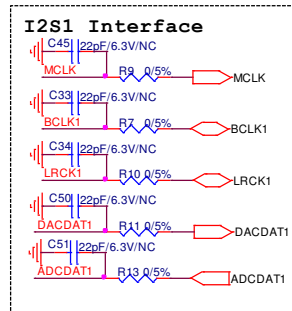
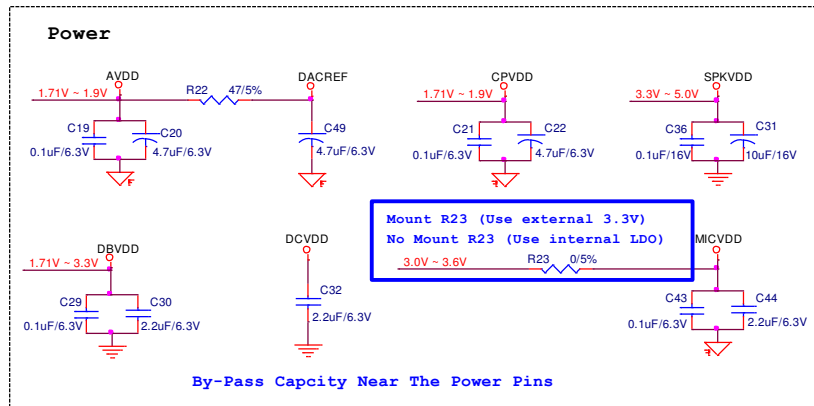
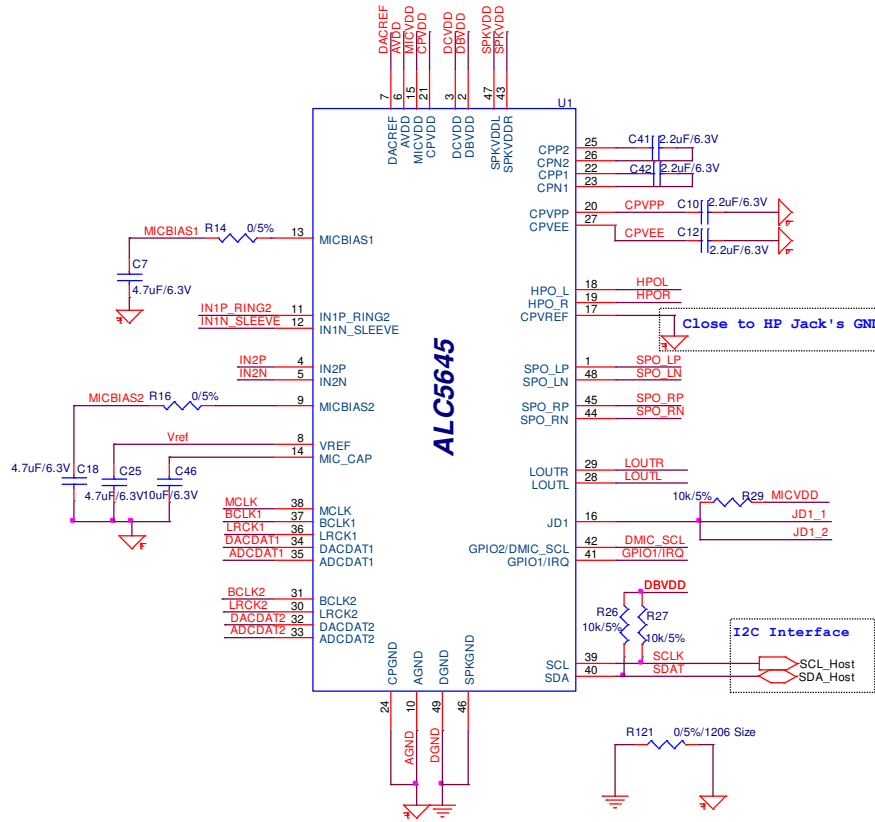


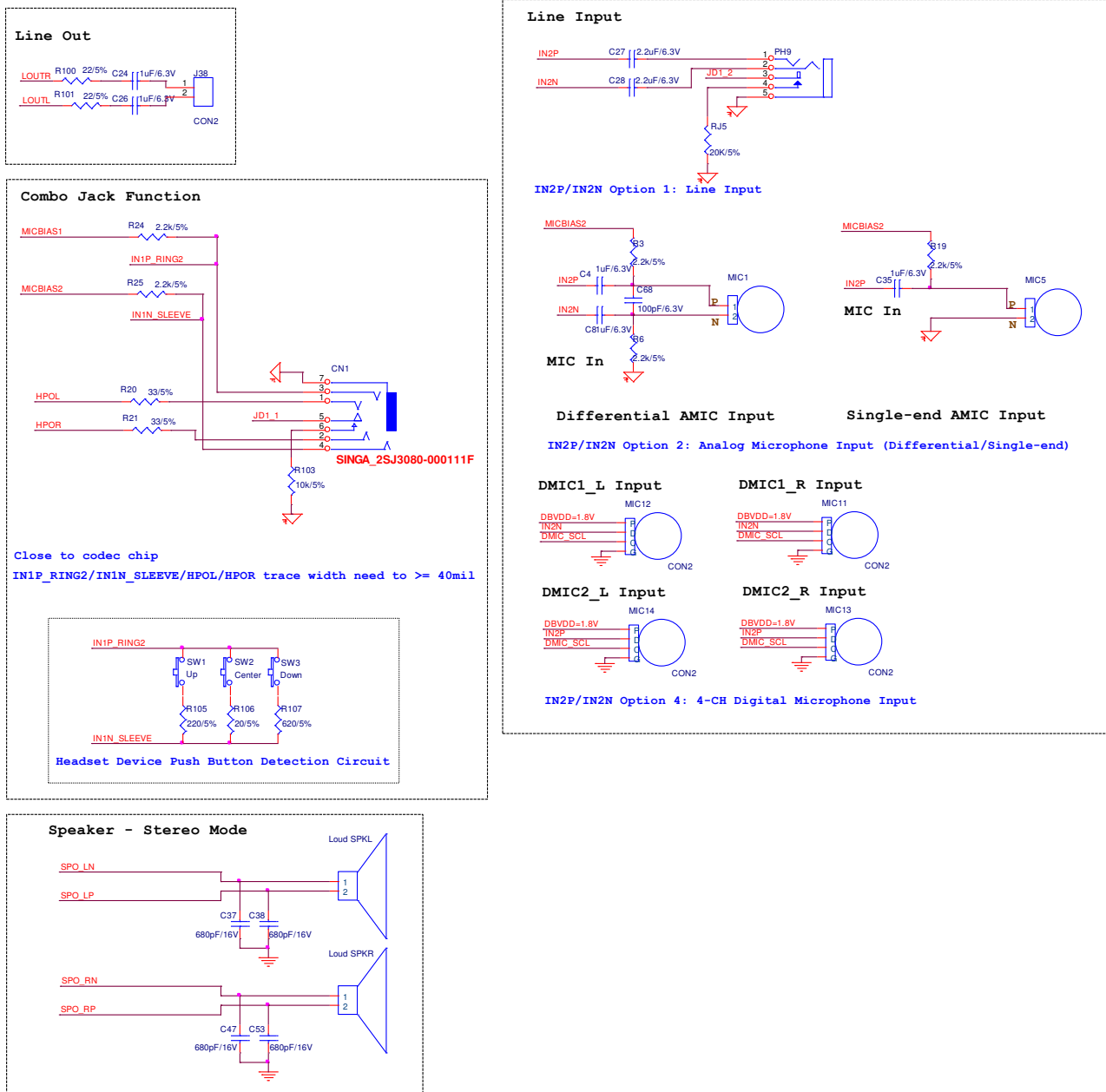
Figure 35. Digital Microphone Interface Timing

Table 229. Digital Microphone Interface Timing

Parameter	Symbol	Min	Typ	Max	Units
Clock Output Rate	T_{CLKOUT}	300	-	-	ns
Clock Duty Cycle		45:55		55:45	
Data Input Setup Time	T_{DAS}	20	-	-	ns
Data Input Hold Time	T_{DAH}	10	-	-	ns

11. Application Circuits

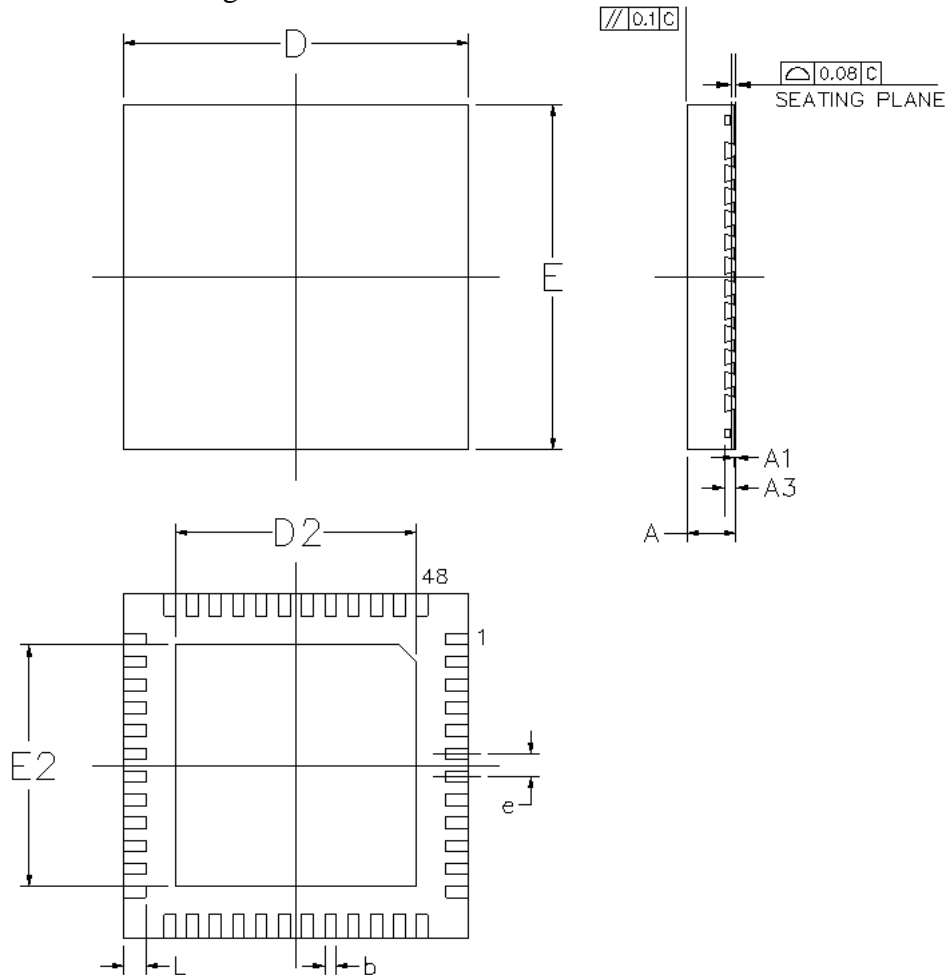



Figure 36. Application Circuit

12. Package Information

12.1. Mechanical Dimensions

Plastic Quad Flat No-Lead Package 48 Leads 6x6mm² Outline



Symbol	Dimension in mm			Dimension in inch		
	Min	Nom	Max	Min	Nom	Max
A	0.75	0.85	1.00	0.030	0.034	0.039
A ₁	0.00	0.02	0.05	0.000	0.001	0.002
A ₃	0.20 REF			0.008 REF		
b	0.15	0.20	0.25	0.006	0.008	0.010
D/E	6.00BSC			0.236BSC		
D2/E2	4.15	4.4	4.65	0.163	0.173	0.183
e	0.40BSC			0.016BSC		
L	0.30	0.40	0.50	0.012	0.016	0.020

Notes ..

1. CONTROLLING DIMENSION .. MILLIMETER(mm).
2. REFERENCE DOCUMENTL .. JEDEC MO-220.

Figure 37. Package Dimension

12.2. Package Thermal Information

Table 230. Thermal Information

Parameter	Symbol	Min	Typ	Max	Units
QFN48 (6x6) Thermal Impedance (Junction to Case)	θ_{jc}	-	8.4	-	°C/W
QFN48 (6x6) Thermal Impedance (Junction to Ambient)	θ_{ja}	-	28	-	°C/W

*Follow JEDEC PCB:

1. PCB Dimension (L x W): 114.3mm x 101.6mm
2. PCB Thickness: 1.6mm
3. Number of Cu Layer-PCB: 4-layers (2S2P)
4. PCB Via Number: 10
5. Air flow: 0 (m/s)

13. Ordering Information

Table 231. Ordering Information

Part Number	Package	Status
ALC5645-CG	48-Pin QFN (6mm x 6mm) in 'Green' Package (Tray)	Sample
ALC5645-CGT	48-Pin QFN (6mm x 6mm) in 'Green' Package (Tape & Reel)	Sample
ALC5645R-CG	48-Pin QFN (6mm x 6mm) in 'Green' Package (Tray)	Sample
ALC5645R-CGT	48-Pin QFN (6mm x 6mm) in 'Green' Package (Tape & Reel)	Sample

* "R" is special for certain assign project purpose, not for general purpose.

Realtek Semiconductor Corp.**Headquarters**

No. 2, Innovation Road II

Hsinchu Science Park, Hsinchu 300, Taiwan

Tel.: +886-3-578-0211. Fax: +886-3-577-6047

www.realtek.com