

Paperless Recording System

PAPERLESS RECORDER

(Selectable input modules; TFT LCD display)

Functions & Features

- 20 msec. storing rate with the combination of 8 analog and 8 discrete inputs
- 0.1 sec. storing rate with 16 channels; 0.5 sec. with 64 channels
- Data stored in CF Cards and SD Cards
- Indicated interval data stored in USB memory as CSV file operable (even during storing)
- Memory card slot accessible at the front
- Dedicated application software to view and analyze the data
- Touch panel operation
- IP65 front panel
- Display and storing of the data sent from PLC in combination with Gateway module
- Setting and operation from PLC (Remote Mode)

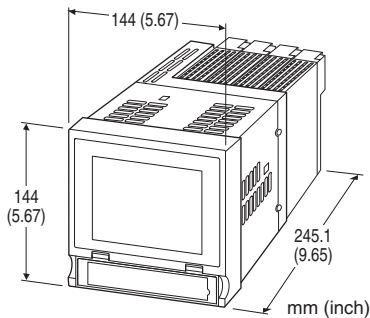

MODEL: 73VR3100-[1]-[2][3]

ORDERING INFORMATION

- Code number: 73VR3100-[1]-[2][3]
- Specify a code from below for each of [1] through [3].
(e.g. 73VR3100-E-M2/Q)
- I/O and network modules
(Use Ordering Information Sheet No. ESU-7397)
 - Specify the specification for option code /Q
(e.g. /C01/HA)

[1] LANGUAGE

N: Japanese
E: English

[2] POWER INPUT

AC Power

M2: 100 - 240 V AC (Operational voltage range 85 - 264 V, 47 - 66 Hz)

DC Power

R: 24 V DC
(Operational voltage range 24 V ±10 %, ripple 10 %p-p max.)

[3] OPTIONS

blank: none

/Q: With options (specify the specification)

SPECIFICATIONS OF OPTION: Q (multiple selections)

COATING (For the detail, refer to M-System's web site.)

/C01: Silicone coating

/C02: Polyurethane coating

/C03: Rubber coating

INSTALLATION

/HA: Desktop type (with handle and feet)

(Desktop type cannot be mounted on a panel surface.

The handle and rubber feet cannot be detached.)

RELATED PRODUCTS

- PC Configurator cable (model: MCN-CON or COP-US)
- PC configurator software (model: R3CON)
- Clamp-on current sensor (model: CLSA, CLSB, CLSE)
- Special cable for the CLSA-08, -12 (model: CLSA-08C-30)

■ Memory card

A memory card is required to store data in the 73VR3100. Available for purchase from M-System. Consult M-System (except SD/CF conversion adapter).

M-System will not guarantee the product's described performance if a memory card other than purchased from M-System, or specified below, is used.

- CF Card

1. Manufacturer: Hagiwara Solutions

Model No.: MCF10P-xxxxS

Capacity: 128 MB through 1 GB

(CFI-xxxxDG ... discontinued)

2. Manufacturer: Apacer Technology

Model name: CFC III

Model No.: AP-CFxxxxE3NR-ETNDNRQ

Capacity: 256 MB through 1 GB

Part No.: 81.27L20.TB47C (256 MB)

81.29910.TB37C (512 MB)

81.29920.TB37C (1 GB)

(AP-CFxxxxE3ER-ETNDNR, AP-CFxxxxE3ER-ETNDNRK ... discontinued)

- SD Card (Compatible with 73VR3100 Ver.6.02.xx or later)

Manufacturer: Hagiwara Solutions

Model No.: NSD6-004GH (B21SEI)

(NSDA-004GT, NSDA-004GL ... discontinued)
SD/CF Conversion Adapter is required to use SD card. There are some restrictions on using SD card. For details, refer to the instruction manual.

- SD/CF Conversion Adapter (operation confirmed):
DeLOCK adaptor CF II to SDHC,SDXC
Model: 61796 (operation has been confirmed with the adapter purchased in the year of 2016.)
62637 (operation has been confirmed with the adapter purchased in the year of 2018.)
Note: Refer to the data sheets of the respective models.

PACKAGE INCLUDES...

- 73VR Application Software CD (model: 73VRPAC2)
- Mounting brackets (two)
(/HA: Not included for desktop type)

I/O, INTERFACE I/O, AND NETWORK MODULE

■ COMMON INSTRUCTION

Use Ordering Information Sheet (No. ESU-7397) to specify the types of I/O module, network module and interface I/O module (gateway module). The total current consumption of all mounted modules must be within 560 mA (continuous). Please refer to the respective data sheet for detailed specifications of each module.

■ SELECTABLE I/O MODULES

R3 Series I/O modules as listed below are used for the 73VR3100.

● I/O MODULE

R3-[1][2]

[1] MODEL

Analog Input

SS4: DC current input, 4 ch.
SS8: DC current input, 8 ch.
SS8N: DC current input, 8 ch., non-isolated
SS16N: DC current input, 16 ch., non-isolated
SV4: DC voltage input, 4 ch.
SV4A: DC voltage input, 4 ch., narrow span
SV4B: DC voltage input, 4 ch., wide span
SV4C: DC voltage input, 4 ch., wide span ± 50 V
SV8: DC voltage input, 8 ch.
SV8A: DC voltage input, 8 ch., narrow span
SV8B: DC voltage input, 8 ch., wide span
SV8C: DC voltage input, 8 ch., wide span ± 50 V
SV8N: DC voltage input, 8 ch., non-isolated
SV16N: DC voltage input, 16 ch., non isolated
TS4: Thermocouple input, 4 ch.

TS8: Thermocouple input, 8 ch.
RS4: RTD input, 4 ch.
RS8: RTD input, 8 ch.
MS4: Potentiometer input, 4 ch.
MS8: Potentiometer input, 8 ch.
US4: Universal input, 4 ch.
DS4: 4 - 20 mA input with excitation, 4 ch.
DS4A: 4 - 20 mA input w/exc. (switch provided), 4 ch.
DS8N: 4 - 20 mA input with excitation, 8 ch., non-isolated
CT4: CT (AC current) input, 4 ch.
CT4A: AC current input, 4 ch., clamp-on current sensor CLSA use
CT4B: AC current input, 4 ch., clamp-on current sensor CLSB use
CT4C: AC current input, 4 ch., clamp-on current sensor CLSB -R5 use
CT8A: AC current input, 8 ch., clamp-on current sensor CLSA use
CT8B: AC current input, 8 ch., clamp-on current sensor CLSB use
CT8C: AC current input, 8 ch., clamp-on current sensor CLSB -R5 use
PT4: PT (AC voltage) input, 4 ch.
CZ4: Zero-phase current input, 4 ch.
WT4: AC power input, 4 points
WT4A: AC power input, 4 ch., clamp-on current sensor CLSA use
WT4B: AC power input, 4 ch., clamp-on current sensor CLSB use
WTU: AC power input, 2 ch., clamp-on current sensor CLSE use (Communication Mode 'S' only)
LC2: Strain gauge input, 2 ch.

Pulse Input

PA2: Encoder input, 2 ch. (speed and position)
PA4: High speed pulse input, 4 ch.
PA4A: High speed totalized pulse input, 4 ch.
PA4B: Low speed totalized pulse input, 4 ch.
PA8: Totalized pulse input, 8 ch.
PA16: Totalized pulse input, 16 ch.

Discrete Input

DA16: Optical isolation discrete input, 16 ch. (13 V DC)

Discrete Output

DC16: Relay output, 16 ch.
DC32A: Open collector output, 32 ch.
(Limited to two discrete output modules at the maximum.)

Discrete I/O

DAC16A: Discrete input output module (Di 8 ch., Do 8 ch.)
(Limited to one discrete I/O module at the maximum.)

Alarm

AS4: DC current input alarm, 4 ch.
AS8: DC current input alarm, 8 ch.
AV4: DC voltage input alarm, 4 ch.

AV8: DC voltage input alarm, 8 ch.
AT4: Thermocouple input alarm, 4 ch.
AR4: RTD input alarm, 4 ch.
AD4: 4 – 20 mA input alarm w/exc., 4 ch.

Blank Filler Module

DM: Blank filler module (Communication mode suffix code is not applicable to the blank filler module.)

[2] COMMUNICATION MODE

S: Single
W: Dual (Select the /W code when a Network Module is used.)

● I/O MODULE WITH CONNECTOR TERMINAL

R3Y-[1][2]

[1] MODEL

Analog Input(FCN connector)

SS8: DC current input, 8 ch.
SS8N: DC current input, 8 ch., non-isolated
SV8: DC voltage input, 8 ch.
SV8N: DC voltage input, 8 ch., non-isolated
SV16N: DC voltage input, 16 ch., non-isolated
RS8: RTD input, 8 ch.

MS8: Potentiometer input, 8 ch.

Pulse Input(FCN connector)

PA16: Totalized pulse input, 16 ch.

Discrete Input(FCN connector)

DA16: Optical isolation discrete input, 16 ch. (13 V DC)

Discrete Output(FCN connector)

DC16: Realy output 16 ch. (Limited to two discrete output modules at the maximum.)

[2] COMMUNICATION MODE

S: Single
W: Dual (Select the /W code when a Network Module is used.)

● R3-CTxA, R3-CTxB, R3-WT4x, R3-WTU

In order to use models R3-CTxA, R3-CTxB, R3-WT4x and R3-WTU, the data range must be set up with the R3 Configurator Software (model: R3CON). This change of setting may lower the resolution of recorded data for certain input ranges.

The R3CON Configurator Software is available for downloading at M-System's web site. A special cable is required to connect the R3 modules to a PC.

The Clamp-on Current Sensors, NOT included in the product package of the R3 modules, must be purchased separately. Please refer to data sheet for the respective models (CLSA

or CLSB or CLSE).

The CLSA is used for the R3-CT4A and R3-CT8A and R3-WT4A.

The CLSB is used for the R3-CT4B and R3-CT8B and R3-WT4B.

The CLSB-R5 is used for the R3-CT4C and R3-CT8C.

The CLSE is used for the R3-WTU.

● R3-PA2

The R3-PA2 can handle a data range of -1 000 000 000 to 1 000 000 000 to represent encoder's positions, while the 73VR3100 can handle only from 0 to 1 000 000 000.

Be sure that the input to the R3-PA2 remains within this range.

The R3-PA2's alarm output cannot be triggered from the 73VR3100.

● R3-DAC16A

Mode setting is available only for continuous output mode.

■ STORING RATE

Possible storing rates depend upon the I/O module types.

TYPE	STORING RATE		
	20ms	0.1s	≥ 0.5s
R3-SS4	Y	Y	Y
R3(Y)-SS8	---	Y	Y
R3(Y)-SS8N	---	Y	Y
R3-SS16N	---	Y	Y
R3-SV4	Y	Y	Y
R3-SV4A	Y	Y	Y
R3-SV4B	Y	Y	Y
R3-SV4C	Y	Y	Y
R3(Y)-SV8	---	Y	Y
R3-SV8A	---	Y	Y
R3-SV8B	---	Y	Y
R3-SV8C	---	Y	Y
R3(Y)-SV8N	Y	Y	Y
R3-SV16N	---	Y	Y
R3Y-SV16	---	Y	Y
R3-TS4	---	---	Y
R3-TS8	---	---	Y
R3-RS4	---	---	Y
R3(Y)-RS8	---	---	Y
R3-US4	---	---	Y
R3-DS4	Y	Y	Y
R3-DS4A	Y	Y	Y
R3-DS8N	---	Y	Y
R3-CT4	---	---	Y
R3-CT4A	---	---	Y
R3-CT4B	---	---	Y
R3-CT4C	---	---	Y
R3-CT8A	---	---	Y
R3-CT8B	---	---	Y
R3-CT8C	---	---	Y
R3-PT4	---	---	Y
R3-PA2	---	---	Y
R3-PA4	---	---	Y
R3-PA4A	---	---	Y
R3-PA4B	---	---	Y
R3-PA8	---	---	Y
R3(Y)-PA16	---	---	Y
R3-WTU	---	---	Y
R3-WT4	---	---	Y
R3-WT4A	---	---	Y
R3-WT4B	---	---	Y
R3-MS4	Y	Y	Y
R3(Y)-MS8	---	Y	Y
R3-LC2	---	Y	Y
R3-CZ4	---	Y	Y
R3-AS4	Y	Y	Y
R3-AS8	---	Y	Y
R3-AV4	Y	Y	Y
R3-AV8	---	Y	Y
R3-AD4	---	---	Y
R3-AT4	---	---	Y
R3-AR4	---	---	Y
R3(Y)-DA16	Y	Y	Y
R3(Y)-DC16	---	---	Y
R3-DC32A	---	---	Y
R3-DAC16A	---	---	Y

[Legend] Y = Selectable, --- = Not Selectable

■ SELECTABLE NETWORK MODULES

R3 Series network modules as listed to below are usable for the 73VR3100.

R3-[1]-N

[1] MODEL

NC1: CC-Link (Ver. 1; 16-point analog)
 NC2: CC-Link (Ver. 1; 32-point analog)
 NC3: CC-Link (Ver. 2)
 ND1: DeviceNet (16-point analog)
 ND2: DeviceNet (32-point analog)
 ND3: DeviceNet (64-point analog)
 NE1: Ethernet (Modbus/TCP)
 NF1: T-Link (Fuji Electric)
 NM1: Modbus
 NP1: PROFIBUS-DP
 NL1: LonWorks (16-point analog)

POWER INPUT

N: No power supply

● CAUTIONS OF USING THE R3 SERIES NETWORK MODULE

One R3 Series network module is mountable at the position of I/O Module 4. In the dual communication mode, the 73VR3100 is automatically defined as 'main' bus, while the R3 network is as 'sub.' The R3 network module cannot output through output modules. Choose I/O modules with dual communication mode (code 'W').

■ SELECTABLE INTERFACE I/O MODULE (GATEWAY MODULE)

R3 Series interface I/O modules as listed below are usable for the 73VR3100.

R3-[1]S

[1] MODEL

GC1: CC-Link (Ver.1.10/Ver.2.00)
 GD1: DeviceNet (for 64-point analog signals)
 GE1: Modbus/TCP (Ethernet)
 GM1: Modbus (RS-485)
 GFL1: FL-net (Ver. 2.0; OPCN-2)

COMMUNICATION MODE

S: Single

■ CAUTIONS OF USING THE R3 SERIES INTERFACE I/O MODULE

- Interface I/O Modules support analog data only, not for digital data.
- 73VR3100 cannot output analog data. Only analog data input via Interface I/O Module is available.
- 73VR3100 can receive maximum 64 words for input data.
- Storing Interval 20 msec. is not supported. When 73VR3100 is in Remote Mode, storing Interval 20 msec. and 100 msec. are not supported.

GENERAL SPECIFICATIONS

Construction: Panel mount type or desktop type
Degree of protection: IP65; applicable to the front panel of the recorder with single mounting according to the specified panel cutout (/HA: Desktop type cannot be mounted on a panel surface)

■ CONNECTION

Power input: Euro type connector terminal
Applicable wire size: 0.2 - 2.5 mm² or AWG 24 - 12 for both stranded and solid wires. stripped length 7 mm. Use pin terminals with stranded wires.
Ethernet: RJ-45 Modular Jack

■ MATERIALS

Enclosure: Steel
Bezel: Flame-resistant resin (black)
Front filter: Transparent resin

■ INTERFACE

Ethernet: 10BASE-T / 100BASE-TX automatically switched; Conforms to IEEE 802 (10BASE-T) or IEEE 802.3 (100BASE-TX)

IP address: 192.168.0.1 (factory default setting)
Subnet mask: 255.255.255.0 (factory default setting)
Default gateway: None (factory default setting)
CF Card slot: Type I; for use with the cards' operating voltage 3.3 V

USB: Conforms to Version 1.1

■ DISPLAY

Display device: 5.5-inch TFT LCD
Display colors: 256
Resolution: 320 × 240 pixels
Pixel pitch: 0.12 × 0.35 mm
Note: The backlight can be replaced in M-System factory. The LCD must be replaced at the same time.

INSTALLATION

Power consumption

- AC:
Approx. 36 VA at 100 V
Approx. 46 VA at 240 V
- DC: Approx. 24 W, approx 1.0 A

Operating temperature: 0 to 50°C (32 to 122°F)
Display quality (e.g. decreased contrast) may deteriorate when the recorder is used for a long time in an environment exceeding 50°C. However, it is only a temporary phenomenon. When the recorder is back in normal temperature, full legibility is recovered. No damage in performance.

Operating humidity: 30 to 85 %RH (non-condensing)
Allowable dust particles: 0.1 mg/m² (no conductive particles)
Corrosive gas: Not allowed
Mounting: Panel flush mounting (except desktop type)
Panel cutout dimensions: 137 × 137 mm (5.39" × 5.39")

Weight: 2.3 kg (5.1 lb) except I/O modules
Caution: Use of UPS (switching time: without delay, output: sine waveforms) is recommended to prevent data loss or CF card damage by a loss of power during recording.

PERFORMANCE

Calendar clock accuracy: Monthly deviation 3 minutes at 25°C

Insulation resistance: ≥ 100 MΩ with 500 V DC (power to Ethernet to FG)
Refer to respective data sheet of R3 Series for I/O insulation.

Dielectric strength

AC power: 2000 V AC @1 minute (power to Ethernet or FG)
500 V AC @1 minute (Ethernet to FG)
DC power: 1250 V AC @1 minute (power to Ethernet or FG)
500 V AC @1 minute (Ethernet to FG)
Refer to respective data sheet of R3 Series for I/O and I/O-to-FG strength.

APPLICATION SOFTWARE CD

■ 73VRPAC2 (included in the product package)

• 73VR3100 Builder Software: Model 73VR31BLD

Used to configure parameters on the PC.

- Parameter configurations can be downloaded to the recorder via Ethernet.
- Present setting on the 73VR3100 can be uploaded and displayed on the PC.
- Configuration files can be converted into CSV.

• 73VR Data Viewer: Model 73VRWV

Used to show and analyze recorded data on the PC.

- Data stored in the CF Card can be called up on the PC screen via the CF Card Reader.
- Data stored in the CF Card can be sent by FTP and called up on the PC screen.
- Various analyzing functions
- Data and alarm history files can be converted into CSV.

• PC Recorder Software: Model MSR128-V6

- The 73VR3100 data can be sampled and stored in real time via Ethernet by the MSR128-V6.
- Data stored in the CF Card can be sent via Ethernet and called up on the PC screen.
- Data stored in the CF Card can be called up on the PC screen via the CF Card Reader.

• Instruction Manuals

- 73VR3100 users manual
- 73VR31BLD users manual
- 73VRWV users manual
- MSR128-V6 users manual
- 73VR3100 REMOTE MODE Reference Manual

PC REQUIREMENTS (provided by the user)

■ 73VR3100 Builder Software: Model 73VR31BLD

Operating system	Windows 7 Professional (32-bit) or Windows 10 (32-bit, 64-bit) Note: Proper software functions may not be ensured under certain conditions.
Screen area	1024 by 768 pixels or better resolution
CD drive	Windows supported CD drive is used to install the software program.
Card reader	Used to read/write the CF Card
Mouse	Windows supported
LAN card	LAN card required to connect to Ethernet; 10BASE-T or 100BASE-T cable

■ 73VR Data Viewer: Model 73VRWV

Operating system	Windows 7 Professional (32-bit) or Windows 10 (32-bit, 64-bit) Note: Proper software functions may not be ensured under certain conditions.
Screen area	1024 by 768 pixels or higher
Display color	65000 colors (16-bit)
Main memory (RAM)	2 GB recommended
CD drive	Windows supported CD drive is used to install the software program.
Card reader	Used to read/write the CF Card
Mouse	Windows supported (Certain functions of the 73VR may be compromised if the mouse's software driver is not Windows standard.)
LAN card	LAN card required to connect to Ethernet; 10BASE-T or 100BASE-T cable

■ PC Recorder Software: Model MSR128-V6

	NORMAL MODE (storing rates ≥ 500 ms)	HIGH SPEED MODE (storing rates 100 / 200 ms)* ¹
PC	IBM PC/AT or compatible	
Operating system	Windows XP SP1, SP2, SP3, Windows Vista Business (32-bit), Windows 7 Professional (32-bit) or Windows 10 (32-bit, 64-bit) Note: Proper software functions may not be ensured under certain conditions.	
CPU	Pentium III 800 MHz or higher 1 GHz higher for Windows Vista, Windows 7, Windows 10	Pentium IV 2.0 GHz or higher
Screen area	1024 by 768 pixels or better resolution	
Display color	65000 colors (16-bit)	
Video memory	2 MB minimum; 4 MB recommended	4 MB minimum
Main memory	256 MB recommended for Windows XP 1 GB recommended for Windows Vista, Windows 7, Windows 10	512 MB recommended for Windows XP 1 GB recommended for Windows Vista, Windows 7, Windows 10
Hard disk area	Use an internal hard disk.* ² Max. approx. 100 MB required per day.	Use an internal hard disk.* ² Max. approx. 500 MB required per day.
Printer	Use a printer for Windows. The programs use Standard System Fonts used in Windows. Use a printer driver for Standard System Fonts.	
CD drive	Windows supported CD drive is used to install the software program.	
Card reader drive	Used with devices which save data in a CF Card	
Communication port	RS-232-C port (COM1 through COM5) supported LAN card	LAN card by Windows

*1. The 73VR1100 or the 73VR21x cannot be used in High Speed Mode.

*2. External (e.g. SCSI) devices may impair appropriate performance.

EXTERNAL VIEW

■ FRONT VIEW

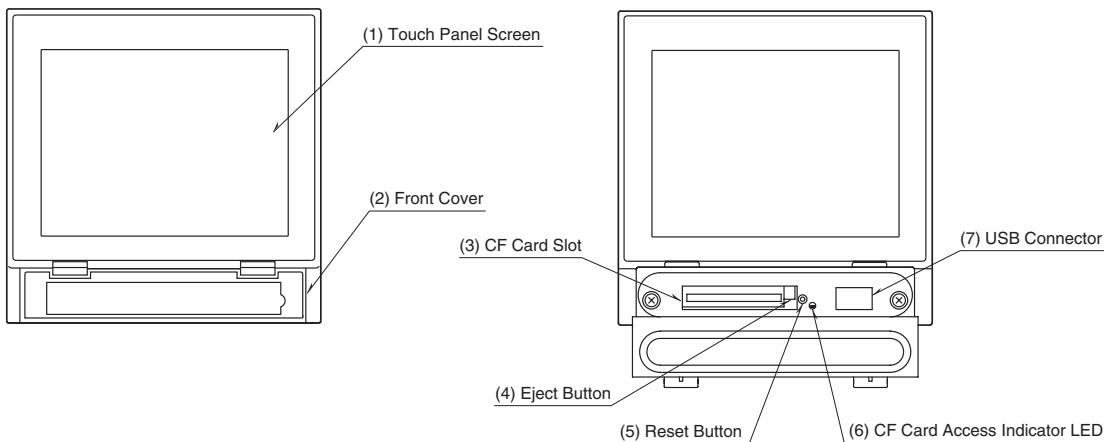

■ REAR VIEW

• With I/O Modules

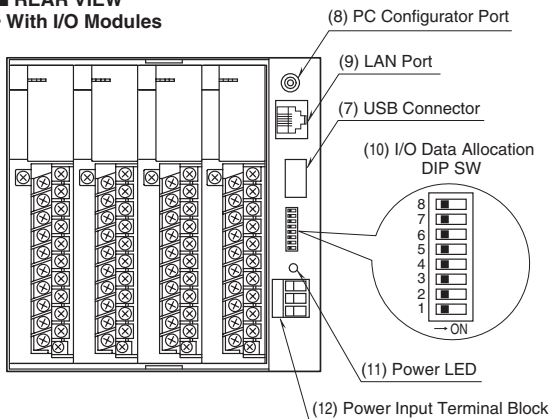

• Without I/O Modules

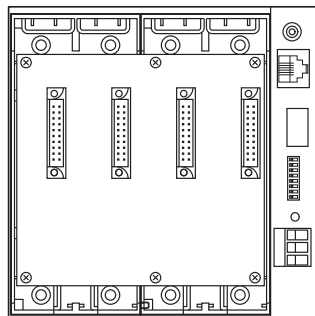

• I/O Module Assignment

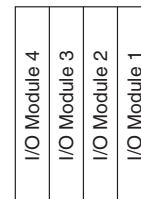

CONNECTION DIAGRAM

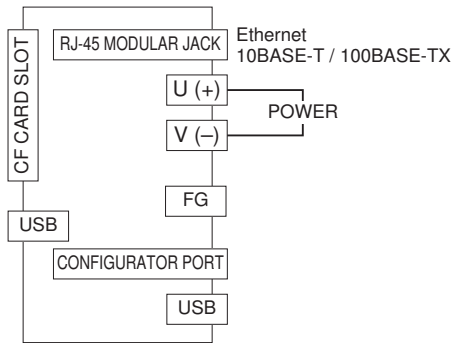

EXTERNAL DIMENSIONS unit: mm (inch)

• Panel mount type

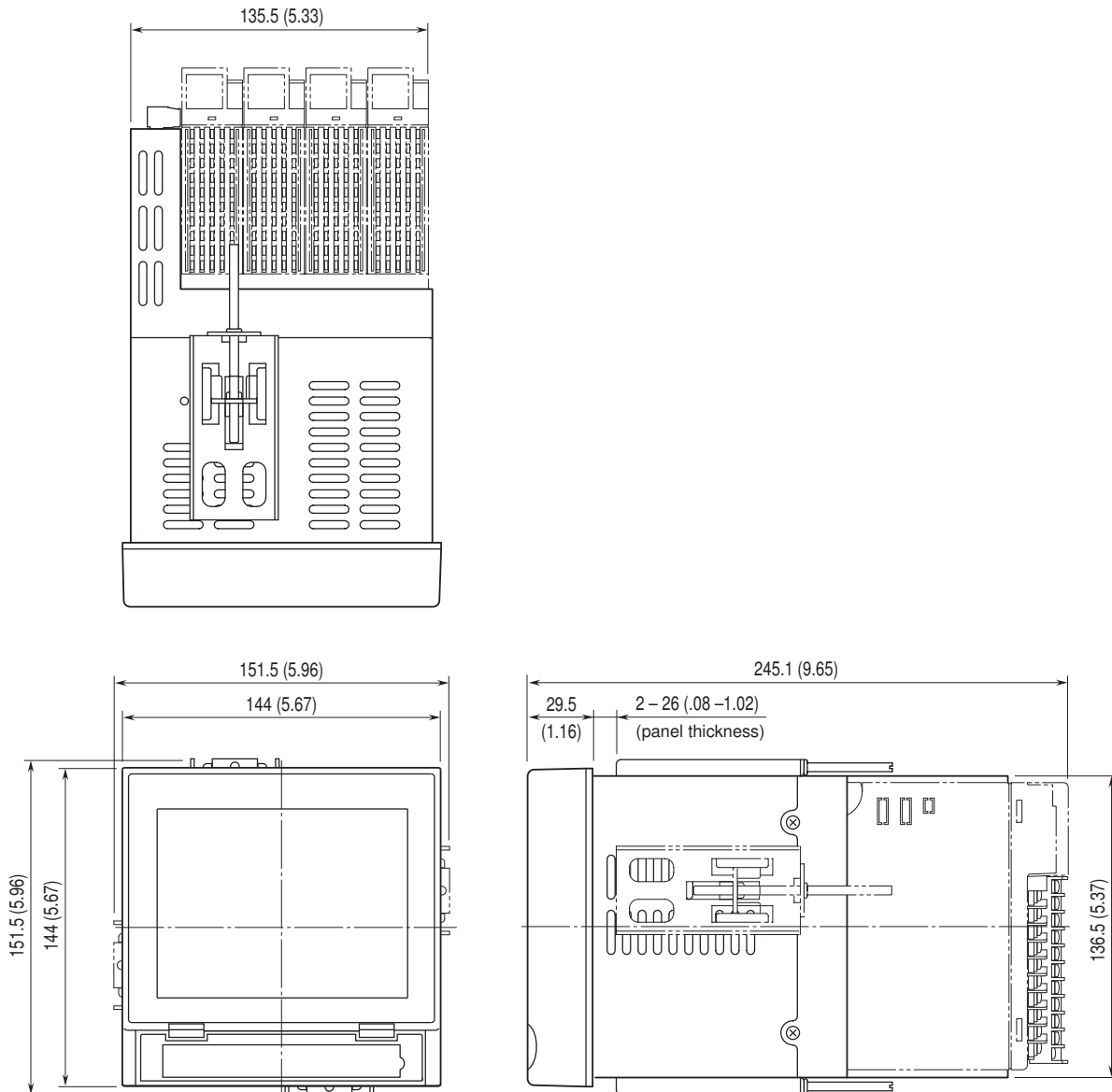

Attach the mounting bracket either on the top/bottom or on the sides.

• Desktop type

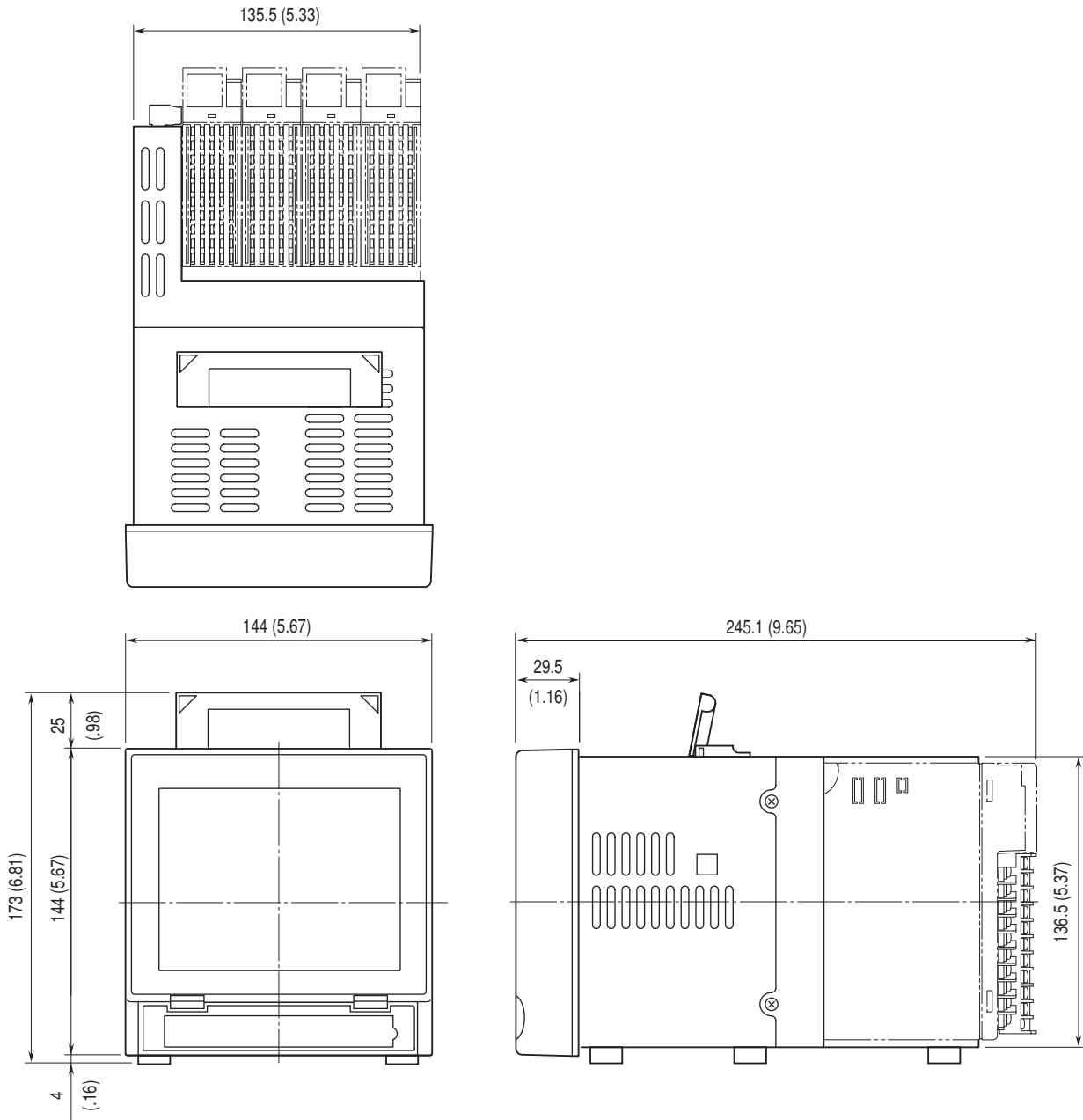

The handle and rubber feet cannot be detached from desktop type unit.

PANEL CUTOUT (unit: mm)

Usable panel thickness: 2 - 26 mm (0.08" - 1.02")

■ SINGLE MOUNTING

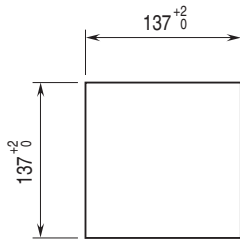

Number	L ⁺² / ₀ (mm)
2	282
3	426
4	570
5	714
6	858
7	1002
8	1146
9	1290
10	1434
n	(114 × n) - 6

Notes

1. The R3 I/O modules mounted on the second and the third 73VR3100 from the top cannot be removed in the vertical clustered mounting.
2. Dimensional tolerance ±3% unless otherwise specified. (±0.3 mm for < 10 mm)
3. Desktop type cannot be mounted on a panel surface.

■ VERTICAL CLUSTERED MOUNTING (max. 3 units)

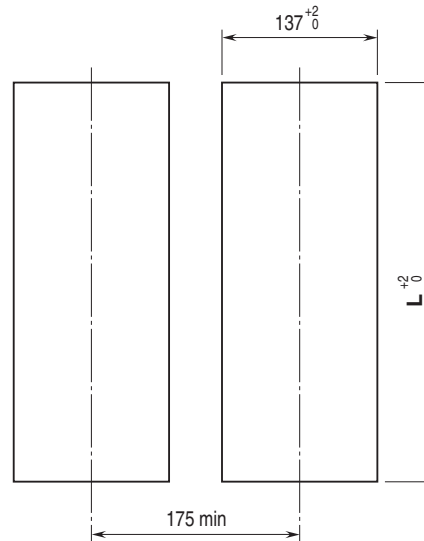

■ HORIZONTAL CLUSTERED MOUNTING

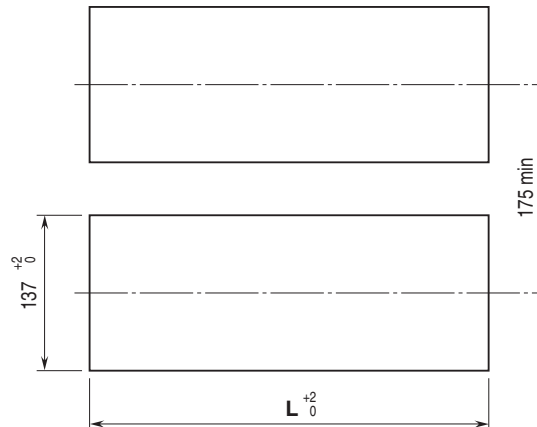

SOFTWARE FUNCTIONS

■ STORING RATE v.s. NUMBER OF INPUT CHANNELS

20 millisc.: 8 analog inputs and 8 discrete inputs

0.1 seconds: Total of 16 analog and/or discrete inputs

0.5 seconds or longer: Total of 64 analog and/or discrete inputs

■ INPUT SIGNALS

Analog: DC voltage/current, thermocouple, RTD, AC voltage/current or pulse

Discrete: Contact signals

■ DATA STORING METHOD

Normal: Recording is manually initiated and stopped. Data is continuously stored while the recording is on.

Auto: Recording is automatically initiated and stopped at a predefined time.

Event recording: The recorder detects an external event by

trigger signal, and stores preset number of samples (max. 1200 respectively) before and after the moment of event.

Remote trigger: Data is automatically recorded while the external trigger condition (input) is true.

■ STORING RATE

20 millisc., 0.1, 0.5, 1, 2, 5, 10 seconds, 1, 10 minutes

■ DATA STORAGE

- CF card

Data file: Stores momentary values in the storing rate and their calculation result.

Alarm history file: Records time index information when alarms are triggered and reset.

Comment history file: Records comments written in trend views with time index. Oldest data is overwritten with new data when the number of records reaches 1000 files.

Configuration file: Stores the 73VR3100 setting.

File format: Binary

Oldest measured data and alarm history data are overwritten with new data when the card memory is full.

• USB memory

Indicated interval data (except alarm history and comment history) stored in USB memory as CSV file is operable (even during storing)

■ ALARM (Available with 0.5 sec. or longer storing rates)

• Analog Alarm

Alarm setpoints: Max. 4 points per channel

Alarm type: High / Low

Deadband: Set in engineering unit values

Output: At the R3-DC16, R3-DC32A and R3-DAC16A

• Discrete Alarm

Alarm type: Either ON or OFF status can be set as alarm.

Delay time: Alarm trips after a specified time delay.

Output: At the R3-DC16, R3-DC32A and R3-DAC16A

• Alarm Data Storage

Stored information: Date/time of alarm events (trip and reset), Pen No., Tag Name and Alarm Message

Number of stored alarm events: Depends upon the CF Card capacity.

128 MB 250 events

256 MB 500 events

512 MB or 1 GB 1000 events

■ CALCULATION FUNCTIONS

Number of channels

20 msec. or 0.1 sec. storing rates: 16 channels

0.5 sec. or longer storing rates: 64 channels

Operations

Arithmetic: Addition/subtraction, Multiplication, Division

Logical: AND, OR, NOT, XOR

Mathematical: Square root extractor, Power

Accumulation: Analog accumulation, Pulse accumulation (per time unit)

Filter: Moving average, First order lag

Hold: Peak (maximum) hold (tracking increasing signal),

Peak (minimum) hold (tracking decreasing signal)

F value: F value

Anemoscope: 16 directions

Alarm

Alarm trip can be programmed for calculated results.

■ DATA DISPLAY FUNCTIONS

From Ver.6.03.09, Overview, Trend and Bargraph views are updated even while "stop" operation status.

• Trend View

Chart direction: Perpendicular or horizontal

Number of pens displayed: 2, 4, 6, 8 per view

Number of display views: 4

Chart speed: pixel(s)/samples

4 (Not selectable with the storing rate 20 millsec.), 1, 1/5, 1/32, 1/160 (Not selectable with the storing rates 20 msec. and 0.1 sec.), 1/480 (Not selectable with the storing rates 20 msec. and 0.1 sec.) or 1/960 (Not selectable with the storing rates 20 msec. and 0.1 sec.)

(Chart speed is described as number of pixels to plot single data sample.)

Display rate: 1 sec.

Pen thickness: Normal and wide

Digital indicator: Shows momentary value.

Alarm indicator: Shows alarm status of the channels displayed on the screen.

Comment: Shows comments entered manually.

Scale: Linear and square root;

Switchable to the engineering unit scale.

Scroll and stop trend view is available (only in Chart speed: 4 or 1)

• Bargraph View

Bargraph direction: Perpendicular or horizontal

Number of pens displayed: 2, 4, 6, 8 per view

Number of display views: 4

Display rate: 1 sec.

Digital indicator: Shows momentary value.

Alarm indicator: Shows alarm status of the channels displayed on the screen.

Scale: Linear and square root; Switchable to the engineering unit scale.

• Overview

Number of pens displayed: 2, 4, 6, 8, 16 per view

Number of display views: 64

Display rate: 1 sec.

Alarm indicator: Shows alarm status and date/time of the last alarm trip and reset for the channels displayed on the screen.

• Retrieve View: Shows data stored in the CF Card.

Number of pens displayed: 2, 4, 6, 8 per view

Number of display views: 4

Data search: Scrolling the chart, specifying a specific time index, or searching by max./min. values.

Data readout: Reading data pointed by the cursor on the screen and showing the readout value.

• Alarm History View: Shows data stored in the alarm history file.

Number of displayed alarm events: 16

Number of display views: 1

Display items: Date/time of alarm events (trip and reset), Pen No., Tag Name and Alarm Message

Display update: Automatically updated by a new event

Data search: Scrolling the view or specifying a specific time index.

Jump: Scroll the view to an alarm event to show the relevant data on Retrieve View.

- **Comment History View:** Shows data stored in the comment history file.

Number of displayed alarm events: 16

Number of display views: 1

Data search: Scrolling the view or specifying a specific time index.

Jump: Scroll the view to a comment to show the relevant data on Retrieve View.

■ ETHERNET COMMUNICATION

Monitoring data and setup of the 73VR3100 is possible on the PC connected via Ethernet.

- **Dedicated Protocol**

Real time communication: Transmits specific data to a host PC installed with the PC Recorder Software (model: MSR128).

FTP communication: Transmits data stored in the CF Card using the FTP protocol to a host PC by the 73VR Data Viewer (model: 73VRWV) installed in it. Data can be transmitted even during recording.

Download, Upload: Software configurations created on the 73VR3100 Configuration Builder (model: 73VR31BLD) can be downloaded to the 73VR3100. The configuration set up on the 73VR3100 can be uploaded and displayed on the 73VR31BLD.

- **Modbus Protocol**

Protocol: Modbus/TCP

Port No.: 502 (fixed)

IP address: Set on the recorder

Subnet mask: Set on the recorder

Default gateway: Set on the recorder

Max. number of 73VR3100 connected simultaneously: 2

Supported Function Codes

CODE	NAME	FUNCTION
01	Read Coil Status	Reads DO
02	Read Input Status	Reads DI
04	Read Input Register	Reads Input Register
05	Force Single Coil	Sets DO
11	Fetch Communication Event Counter	Reads Status Word and Event Counter from Comm. Event Counter
15	Force Multiple Coils	Sets DO (multiple)

Exception Response

CODE	NAME	FUNCTION
01	Illegal Function	Function Not supported
02	Illegal Data Address	Specified address does not exist

Supported Function Codes

	ADDR.	NAME
Coil (0X)	1..256	Alarm output, discrete output
Input Status (1X)	1..256	Trigger input, discrete input
	257..319	Function data (discrete)
Input Register (3X)	1..64	Measured data (analog, 2 bytes)
	257..	Measured data (analog, 4 bytes)
	385..	Function data (analog, 4 bytes)

■ REMOTE MODE

Setting and operation from PLC is available in combination with interface I/O modules.

Please refer to the 73VR3100 REMOTE MODE Reference Manual for detailed information.

■ OTHER FUNCTIONS

- **Operation Lockout**

With a password setting, unauthorized operations on the Trend View, Bargraph View and Overview can be locked out.

- **Data File Used Volume Information**

A bargraph with % indication is provided on the screen to show how much percent of the data file memory has been used up.

0 - 49 % used: Green bargraph

50 - 79 % used: Amber bargraph

80 - 100 % used: Red bargraph

- **Hot Swapping of the CF Card**

The CF Card is hot swappable: removable during data recording. However, there may be a slight disturbance in storing rate when the card is inserted.

- **Screen Saver**

The backlight is automatically turned off if the screen is untouched for a certain time period.

- **Bus Error Alert**

An alarm contact is output at a specified channel of the R3-DC16, R3-DC32A and R3-DAC16A in case of internal bus error. (Only 1 channel can be specified.)

• **Writing/Reading Setting**

The recorder's present setting can be stored in a USB flash-memory. Setting stored in the memory can be read in to the 73VR3100.

• **Trend View Storing Data**

Display trend view data storable in CF card even while "stop" operating status (only in Chart speed: 4 or 1)

■ **STORABLE TIME DURATION IN 1GB CF CARD**

STORING RATE	APPROXIMATE TIME DURATION				
	4 ch input	8 ch input	16 ch input	32 ch input	64 ch input
20 millisec.	approx. 9 days	approx. 5 days, 8 hours	approx. 3 days	---	---
0.1 seconds	approx. 46 days	approx. 27 days, 16 hours	approx. 15 days 8 hours	---	---
0.5 seconds	approx. 231 days	approx. 138 days	approx. 77 days	40 days	20 days, 16 hours
1 second	approx. 1 year, 97 days	approx. 277 days	approx. 154 days	81 days, 16 hours	approx. 42 days
10 seconds	10 years minimum	approx. 7 years, 222 days	approx. 4 years, 83 days	approx. 2 years, 86 days	approx. 1 year 55 days
1 minute	10 years minimum	10 years minimum	10 years minimum	10 years minimum	approx. 6 years 335 days

--- : Not Applicable

Note 1: Data are calculated ones, and thus not guaranteed.

Note 2: Assuming 4 bytes per data per channel.

Note 3: A year is calculated as 365 days.

SYSTEM CONFIGURATION EXAMPLES

■ **INDEPENDENTLY USED**

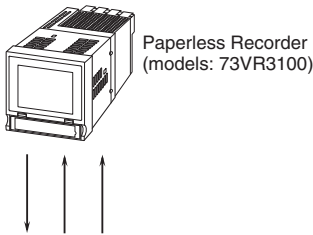

■ **INTERFACING WITH A PC**
• **Reading Data from CF Card**

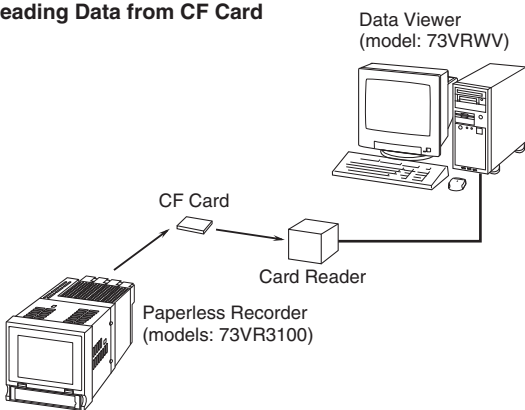

• **Ethernet Connection**

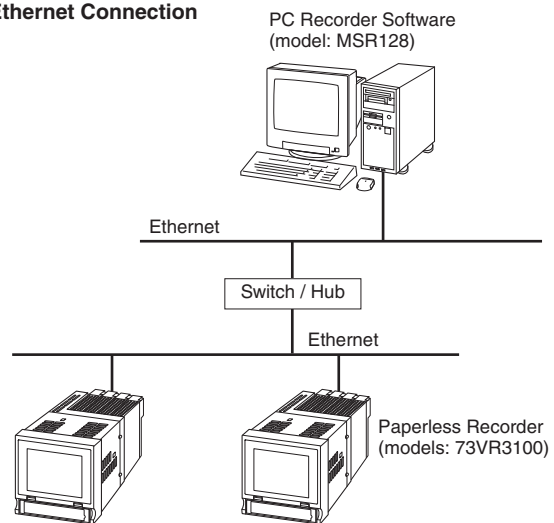

Note: It is recommended to connect the 73VR3100 to the PC using straight cables via a switch/hub on the Ethernet.

■ INTERFACING WITH A PLC/DCS USING A NETWORK MODULE

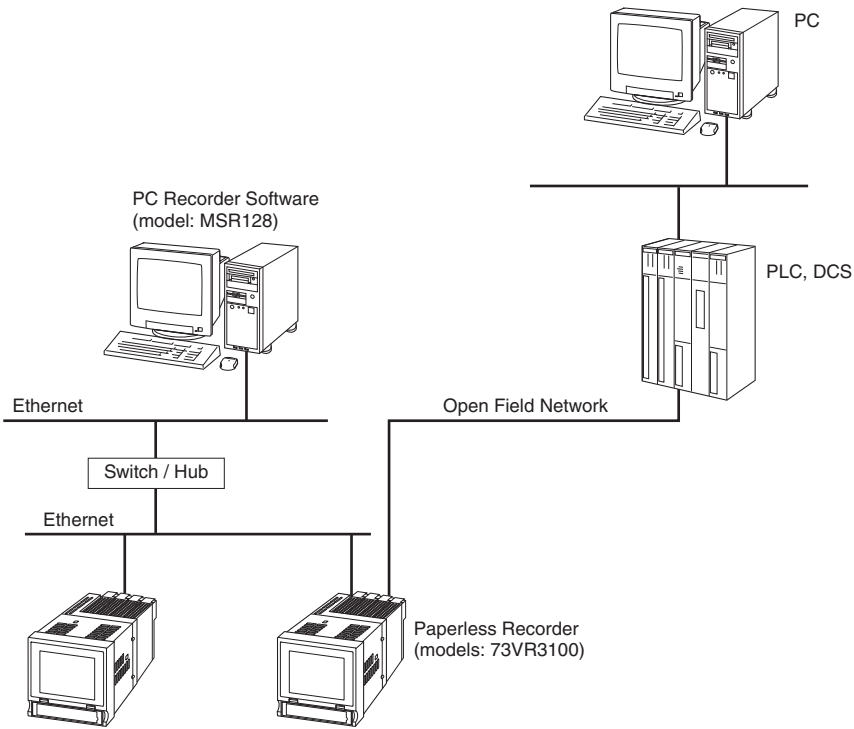

Specifications are subject to change without notice.