

PLEASE CHECK WWW.MOLEX.COM FOR LATEST PART INFORMATION

Part Number: [0877159008](#)

Status: **Active**

Overview:

Description: 1.00mm (.039") Pitch, PCI Express* Connector, 36 Circuits, Nylon 4/6 Glass-filled, Black Housing, Phosphor Bronze, 0.38µm (15µ") Gold (Au) Plating, with Plastic Pegs, 2.30mm (.091") Solder tail, Lead Free

Agency Certification

CSA	LR19980
UL	E29179

General

Product Family	Edge Card Connectors
Series	87715
Comments	PCI 1 lane
Component Type	Edgecard to PCB
Overview	pci_express_card_edge_connector
Product Name	PCI Express*

Physical

Circuits (Loaded)	36
Circuits (maximum)	36
Circuits Detail	All Signal
Color - Resin	Black
Durability (mating cycles max)	50
Entry Angle	Vertical (Top Entry)
Flammability	94V-0
Keying to Mating Part	Yes
Material - Metal	Phosphor Bronze
Material - Plating Mating	Gold
Material - Plating Termination	Tin
Material - Resin	High Temperature Thermoplastic
PC Tail Length (in)	0.091 In
PC Tail Length (mm)	2.30 mm
PCB Locator	Yes
PCB Retention	Yes
PCB Thickness Recommended (in)	0.062 In
PCB Thickness Recommended (mm)	1.60 mm
Packaging Type	Tray
Pitch - Mating Interface (in)	0.039 In
Pitch - Mating Interface (mm)	1.00 mm
Pitch - Term. Interface (in)	0.039 In
Pitch - Term. Interface (mm)	1.00 mm
Plating min: Mating (µin)	15
Plating min: Mating (µm)	0.375
Plating min: Termination (µin)	100
Plating min: Termination (µm)	2.5
Polarized to Mating Part	Yes
Temperature Range - Operating	-55°C to +85°C
Termination Interface: Style	Through Hole

Electrical

Current - Maximum per Contact	1.1A
Voltage - Maximum	50V AC (RMS)/DC

Solder Process Data

Lead-free Process Capability	Wave Capable (TH only)
------------------------------	------------------------

EU RoHS

**ELV and RoHS
Compliant**

REACH SVHC

Contains SVHC: No

Halogen-Free

Status

Not Reviewed

China RoHS



**Need more information on product
environmental compliance?**

Email productcompliance@molex.com
For a multiple part number RoHS Certificate of
Compliance, [click here](#)

Please visit the [Contact Us](#) section for any
non-product compliance questions.

Search Parts in this Series

87715Series

Mates With

PCI Express Card

Process Temperature max. C

245

Material Info

Reference - Drawing Numbers

Packaging Specification

PK-87715-001, PK-87715-207

Product Specification

PS-87715-200

Sales Drawing

SD-87715-207

Test Summary

TS-87715-207

* PCI Express is a registered trademark of PCI-SIG®

This document was generated on 06/04/2010

PLEASE CHECK WWW.MOLEX.COM FOR LATEST PART INFORMATION

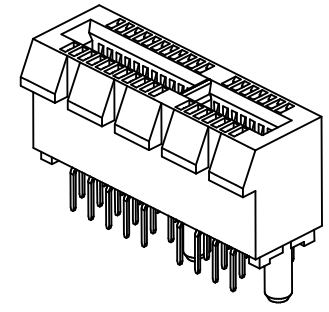
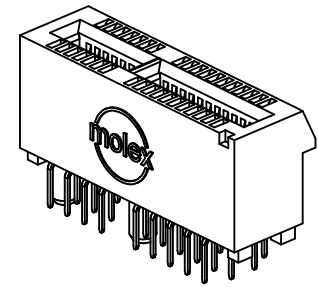
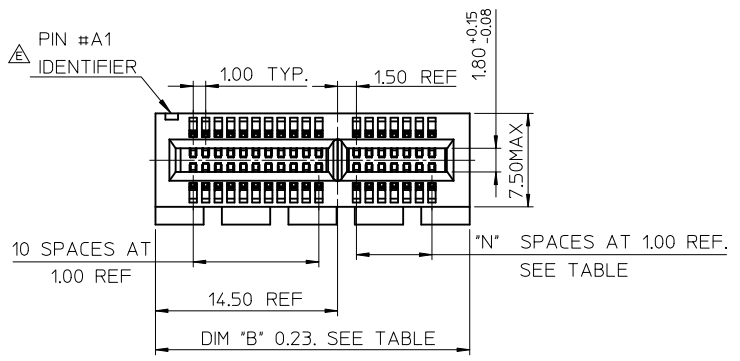

- NOTES:
- 1.MATERIALS:
1-1.HOUSING: SEE TABLE ,GLASS FIBER FILLED UL94V-0, COLOR: SEE TABLE.
1-2.CONTACT: SEE TABLE
 - 2.PLATING:
2-1.CONTACT AREA: GOLD, THICKNESS : SEE TABLE .
2-2.SOLDER TAIL: 100 MICRINCH MIN. TIN PLATING.
2-3.UNDER PLATING: NICKEL PLATING OVERALL.
 - 3.WEEK CODE: XX(YEAR) XXI(WEEK) X(LOCATION).
 - 4.PRODUCT SPECIFICATION REFER TO PS-87715-200.
 - 5.PACKAGING SPECIFICATION REFER TO PK-87715-207.
 - 6.TEST SUMMARY:REFER TO TS-87715-207.
 - 7.LEAD FREE AND ROHS COMPLIANCE PRODUCT.

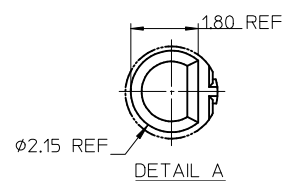
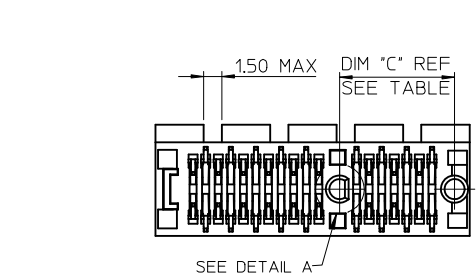
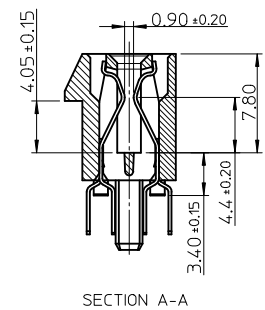
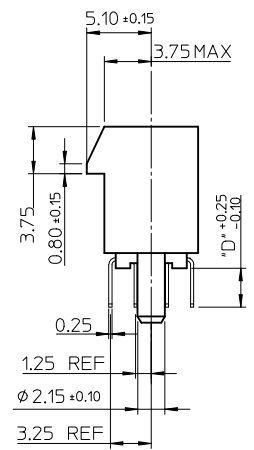
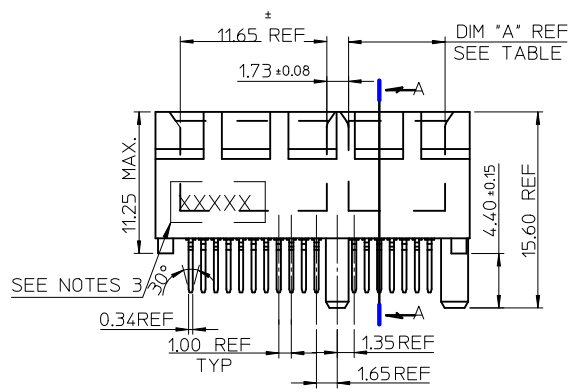

CONNECTOR LINK WIDTH	# POS REF	N	DIM 'A'	DIM 'B'	DIM 'C'
X4	64	20	21.65	39.00	23.15
X8	98	37	38.65	56.00	40.15

PCB THK (REF)	DIM 'D'
1.60	2.30
1.58	2.54
2.36	3.00

REVISED IEC NO: SH2010-0425 DRWR:ZHANG CHYKD:ALLEN L LIN APPR:X.J.SONG	2010/05/14 2004/07/20 2010/06/03	QUALITY SYMBOLS F=0 E=0 A=0	GENERAL TOLERANCES (UNLESS SPECIFIED)		DIMENSION STYLE MM ONLY		SCALE	DESIGN UNITS	THIRD ANGLE PROJECTION		
			mm	INCH	DRAWN BY		DATE	TITLE			
			4 PLACES ± ---	± ---	TOM		2004/07/20	PCI EXPRESS EDGE CARD CONNECTOR (LEAD FREE VERSION)			
			3 PLACES ± ---	± ---	CHECKED BY		DATE				
2 PLACES ± 0.25	± ---	ALLEN LIN		2004/07/20	MOLEX INCORPORATED						
1 PLACE ± 0.25	± ---	APPROVED BY		DATE							
ANGULAR ± 3 °			WILSON		2004/07/20	MOLEX INCORPORATED DOCUMENT NO. SD-87715-207 SHEET NO. 1 OF 4					
DRAFT WHERE APPLICABLE MUST REMAIN WITHIN DIMENSIONS			MATERIAL NO.		DATE						
SEE SHEET 4			SIZE A3		THIS DRAWING CONTAINS INFORMATION THAT IS PROPRIETARY TO MOLEX INCORPORATED AND SHOULD NOT BE USED WITHOUT WRITTEN PERMISSION						

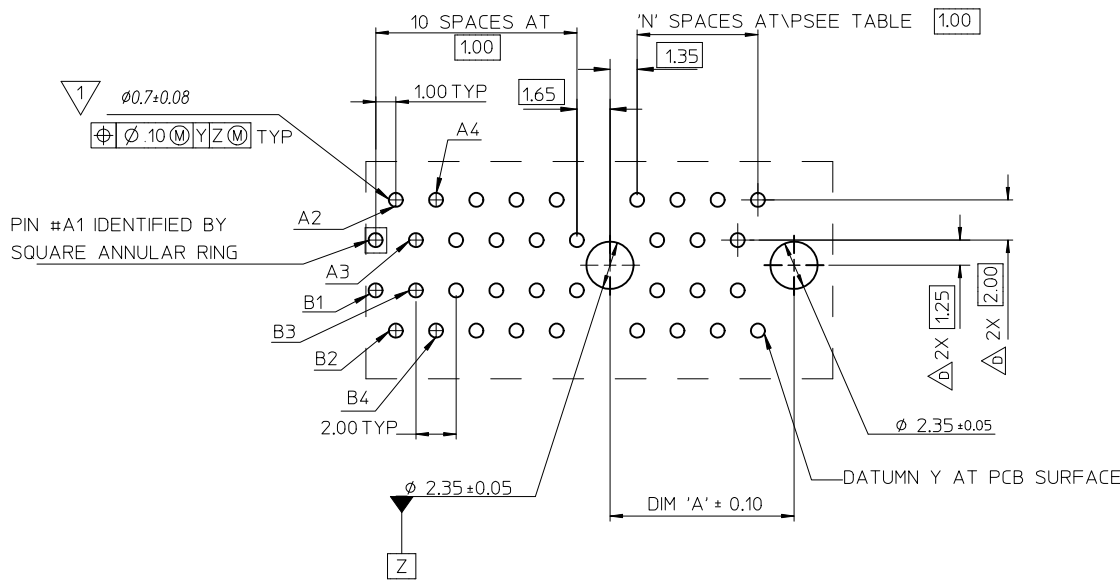

1 THE HORIZONTAL AXIS FOR THE HOLE PATTERN IS ESTABLISHED BY A LINE THROUGH THE CENTER OF THE TWO $\phi 2.35$ HOLES. THE VERTICAL AXIS IS 90° TO THE HORIZONTAL AXIS, THROUGH THE CENTER OF DATUM Z

PIN #A1 IDENTIFIED BY SQUARE ANNULAR RING

CONNECTOR LINK WIDTH	# POS REF	N	DIM 'A'
X4	64	20	23.15
X8	98	37	40.15

SEE SHEET 1	EC NO: SH2010-0425 DRW: RZHANG 2010/05/14 CHK: ALLEN LIN 2004/07/20 APPR: XJSONG 2010/06/03	QUALITY SYMBOLS $F_A=0$ $F_G=0$ $F_P=0$	GENERAL TOLERANCES (UNLESS SPECIFIED)		DIMENSION STYLE MM ONLY		SCALE	DESIGN UNITS METRIC	THIRD ANGLE PROJECTION			
				mm	INCH	DRAWN BY	DATE	TITLE				
			4 PLACES	± ---	± ---	TOM	2004/07/20	PCI EXPRESS EDGE CARD CONNECTOR (LEAD FREE VERSION)				
			3 PLACES	± ---	± ---	CHECKED BY	DATE					
	2 PLACES	± 0.25	± ---	ALLEN LIN	2004/07/20	molex MOLEX INCORPORATED						
	1 PLACE	± 0.25	± ---	APPROVED BY	DATE							
DRAFT WHERE APPLICABLE MUST REMAIN WITHIN DIMENSIONS			ANGULAR ± 3 °		WILSON		2004/07/20	DOCUMENT NO.			SHEET NO.	
					SEE SHEET 4		SD-87715-207			2 OF 4		
					THIS DRAWING CONTAINS INFORMATION THAT IS PROPRIETARY TO MOLEX INCORPORATED AND SHOULD NOT BE USED WITHOUT WRITTEN PERMISSION							

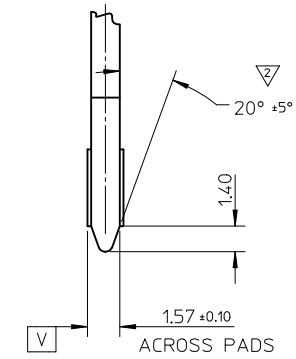
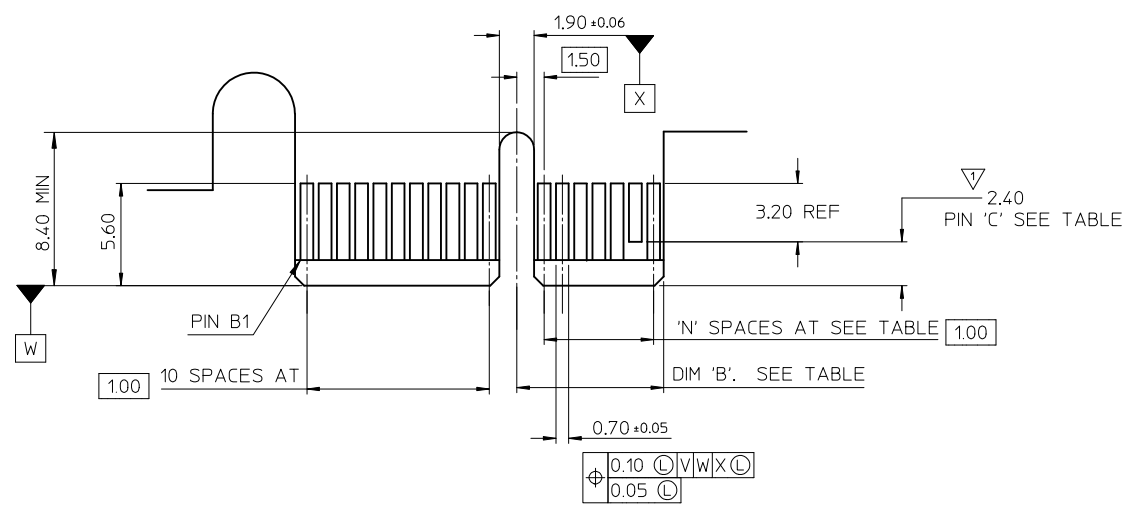

← I/O PANEL DIRECTION

PRIMARY (COMPONENT) SIDE

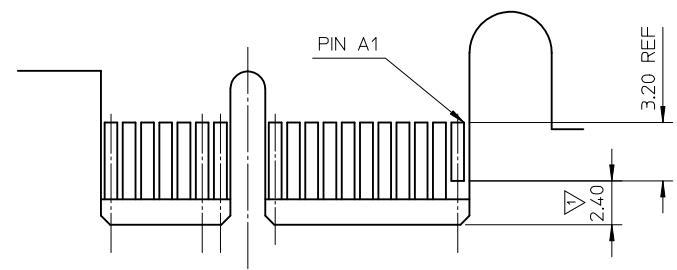

I/O PANEL DIRECTION →

SECONDARY (SOLDER) SIDE

- 1 NO TIE BAR PERMITTED FROM CARD EDGE TO LEADING EDGE OF PAD FOR PINS A1 AND "C".
- 2 CHAMFER EDGES MUST BE FREE OF CUTTING BURRS.
- 3. TOLERANCE: .XX±.13

CONNECTOR LINK WIDTH	# POS REF	N	DIM 'B'	'C'
X4	64	20	22.15	B17, B31
X8	98	37	39.15	B17, B31 B48

SEE SHEET 1 EC NO: SH2010-0425 DR: WNRZhang 2010/05/14 CH: KD-Allen LIN 2004/07/20 APPR: XJ.SONG 2010/06/03	QUALITY SYMBOLS	GENERAL TOLERANCES (UNLESS SPECIFIED)		DIMENSION STYLE	SCALE	DESIGN UNITS	THIRD ANGLE PROJECTION	
	$F_{\text{A}}=0$	mm	INCH	MM ONLY				
	$F_{\text{B}}=0$	4 PLACES ± --- ± ---	3 PLACES ± --- ± ---	DRAWN BY	DATE	TITLE		
	$F_{\text{C}}=0$	2 PLACES ± 0.25 ± ---	1 PLACE ± 0.25 ± ---	CHECKED BY	DATE	PCI EXPRESS EDGE CARD CONNECTOR (LEAD FREE VERSION)		
	ANGULAR ± 3°		APPROVED BY	DATE	MOLEX INCORPORATED			
	DRAFT WHERE APPLICABLE MUST REMAIN WITHIN DIMENSIONS		MATERIAL NO.	DATE	DOCUMENT NO.	SHEET NO.		
			SEE SHEET 4	2004/07/20	SD-87715-207	3 OF 4		
			THIS DRAWING CONTAINS INFORMATION THAT IS PROPRIETARY TO MOLEX INCORPORATED AND SHOULD NOT BE USED WITHOUT WRITTEN PERMISSION					

MOLEX P/N	CIRCUIT SIZE	HOUSING MATERIAL	HOUSING COLOR	TERMINAL MATERIAL	CONTACT PLATING	SOLDER TAIL 'D' LENGTH
87715-9100	64	NYLON46	BLACK	PHOSPHOR BRONZE	GOLD FLASH	2.54
87715-9101					10 MICROINCH	
87715-9102					15 MICROINCH	
87715-9103					GOLD FLASH	3.00
87715-9104					10 MICROINCH	
87715-9105					15 MICROINCH	
87715-9106					30 MICROINCH	2.54
87715-9107					GOLD FLASH	2.30
87715-9108					15 MICROINCH	
87715-9109	30 MICROINCH					

MOLEX P/N	CIRCUIT SIZE	HOUSING MATERIAL	HOUSING COLOR	TERMINAL MATERIAL	CONTACT PLATING	SOLDER TAIL 'D' LENGTH
87715-9200	98	NYLON46	BLACK	PHOSPHOR BRONZE	GOLD FLASH	2.54
87715-9201					10 MICROINCH	
87715-9202					15 MICROINCH	
87715-9203					GOLD FLASH	3.00
87715-9204					10 MICROINCH	
87715-9205					15 MICROINCH	
87715-9206					30 MICROINCH	2.54
87715-9207					GOLD FLASH	2.30
87715-9208					15 MICROINCH	
87715-9209	30 MICROINCH					

MOLEX P/N	CIRCUIT SIZE	HOUSING MATERIAL	HOUSING COLOR	TERMINAL MATERIAL	CONTACT PLATING	SOLDER TAIL 'D' LENGTH
87715-9602	98	NYLON46	BLACK	BRASS	15 MICROINCH	2.54

SEE SHEET 1 EC NO: SH2010-0425 DRWNR:ZHANG 2010/05/14 CHKD:ALLEN LIN 2004/07/20 APPR:XJ.SONG 2010/06/03	QUALITY SYMBOLS	GENERAL TOLERANCES (UNLESS SPECIFIED)	DIMENSION STYLE	SCALE	DESIGN UNITS	THIRD ANGLE PROJECTION
	$F_A=0$ $F_C=0$ $F_P=0$	mm INCH 4 PLACES ± --- ± --- 3 PLACES ± --- ± --- 2 PLACES ± 0.25 ± --- 1 PLACE ± 0.25 ± --- ANGULAR ± 3 °	MM ONLY		METRIC	
	DESCRIPTION	DRAFT WHERE APPLICABLE MUST REMAIN WITHIN DIMENSIONS	DRAWN BY	DATE	TITLE	
	REV		TOM	2004/07/20	PCI EXPRESS EDGE CARD CONNECTOR (LEAD FREE VERSION)	
			CHECKED BY	DATE	MOLEX INCORPORATED	
			ALLEN LIN	2004/07/20	SD-87715-207	
			APPROVED BY	DATE	SHEET NO.	
			WILSON	2004/07/20	4 OF 4	
			MATERIAL NO.	DOCUMENT NO.	THIS DRAWING CONTAINS INFORMATION THAT IS PROPRIETARY TO MOLEX INCORPORATED AND SHOULD NOT BE USED WITHOUT WRITTEN PERMISSION	
			SEE TABLE			