

FCX SERIES LEVEL TRANSMITTER

DATA SHEET

FHE, FKE

The FCX series level transmitter accurately measures, liquid level and transmits proportional 4 to 20mA signal. The transmitter utilizes a unique micromachined capacitive silicon sensor with state-of-the-art microprocessor technology to provide exceptional performance and functionality.

FEATURES

- Outstanding accuracy**
0.2% accuracy for all calibrated spans is the standard feature for all models covering 3.2kPa(32mbar) range to 500kPa(5bar) high differential. Fuji's Micro-capacitance silicon sensor assures this feature for all elevated or suppressed calibration ranges without additional adjustment.
- Minimum environment influence**
"Advanced Floating Cell" design which protects the pressure sensor against changes in temperature, static pressure, and overpressure substantially reduces total measurement error in actual field applications.
- Smart/Traditional convertible**
Fuji micro-electronics manufacturing technology offers free selection of Smart/Traditional transmitters. A small plug-in communication module upgrades your model FHE to smart type model FKE, which has full remote communication capabilities. A Hand Held Communicator (HHC), model FXW can remotely display or reconfigure all transmitter parameters at any point on the loop without affecting the transmitter signal.
- Application flexibility**
Example features that render the FCX series suitable for almost any process applications includes:
 - Analog indicator at either the electronics side or terminal side
 - Full range of hazardous location approvals
 - Built-in RFI filter and lightning arrester
 - 4 digits LCD meter
 - Stainless steel electronics housing
 - Wide selection of materials

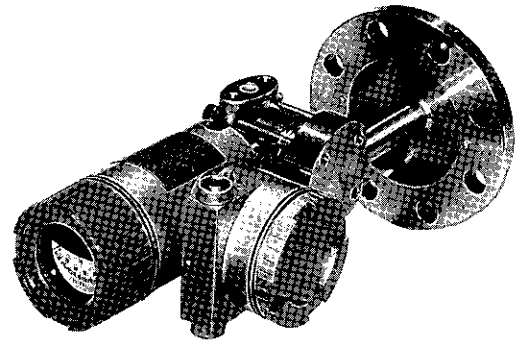

SPECIFICATIONS

Functional specifications

Type:

Model FHE: 4 to 20mA, Traditional type

Model FKE: 4 to 20mA with digital signal, Smart type

Service: Liquid, gas, or vapour

Static pressure, span, and range limit:

Type	Static pressure	Span limit [kPa] (mmH ₂ O)			Range limit [kPa] (mmH ₂ O)
		Min.		Max.	
		FHE	FKE	FHE/FKE	
F□E□□3	Up to flange rating	3.2 (320)	0.32 (32)	32 (3200)	+/- 32 (+/- 3200)
F□E□□4		6.4 (640)	0.64 (64)	64 (6400)	+/- 64 (+/- 6400)
F□E□□5		13 (1300)	1.3 (130)	130 (13000)	+/- 130 (+/- 13000)
F□E□□6		50 (5000)	5 (500)	500 (50000)	+/- 500 (+/- 50000)

Remark: To minimize environment influence, span should be greater than 1/25 of the max. span in most applications.

— Lower limit of static pressure (vacuum limit) is;

Silicone fill sensor: See Fig . 1

Fluorinated fill sensor: 66kPa abs (500m Hg abs) at temperature below 60°C.

—The maximum span of each sensor can be converted to in different units using below factors.

1MPa=10³kPa=10bar=10.19716kgf/cm²=145.0377psi

1kPa=10mbar=101.9716mmH₂O=4.01463inH₂O

Overrange limit: To maximum static pressure limit

Output signal:

Model FHE: 4 to 20mA DC 2 wire, linear signal

Model FKE: 4 to 20mA DC with digital signal superimposed on the 4 to 20mA signal

Power supply: Transmitter operates on 11V to 45V DC at transmitter terminals.
11V to 27V DC for the units with optional arrester.

Load limitations: see figure below

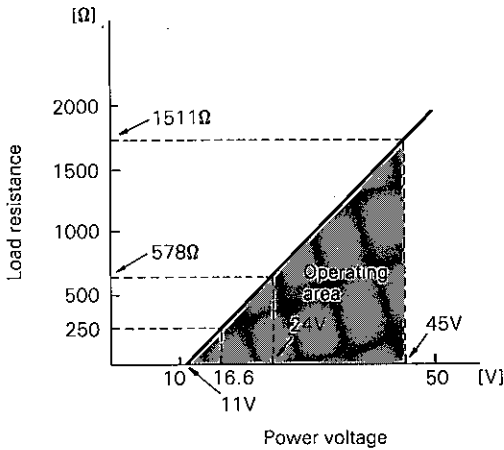

Note: For communication with FXW, min. of 250Ω required.

Hazardous locations:

Designed to meet international intrinsic safety and flameproof (explosionproof) standards.

Authorities	Flameproof	Intrinsic safety	Type N Nonincendive
BASEEFA Factory Mutual	Ex ds IIC T5, T6 Class I II III Div. 1 Groups B thru. G	EEx ia IIC T4, T5 Class I II III Div. 1 Groups A thru. G	Ex N II T5 Class I II III Div. 2 Groups A thru. G
CSA	Class I II III Div. 1 Groups C thru. G	Class I II III Div. 1 Groups A thru. G	Class I II III Div. 2 Groups A thru. G
RIIS SAA NEPSI	ds 2 G4 Exd IIB T6 d IIC T5	i 3a G4 Ex ia IIC T5, T6 ia IIC T4	— — —

Zero/span adjustment:

Model FHE: Zero is adjustable externally from the push buttons (UP and DOWN).

The push buttons can also function to adjust span when MODE SWITCH (located on the front face of electronics unit) is in the span mode. INHIBIT mode to disable the push buttons is also available.

Model FKE: Zero and span are adjustable either from the HHC or by the external push buttons. (one-push function)

Damping: Adjustable electrical damping.

Model FHE: The time constant is adjustable to 0, 0.3, 1.2, 4.8, or 19.2 seconds.

Model FKE: The time constant is adjustable between 0 to 38.4 seconds.

Zero elevation/suppression:

- 100% to + 100% of URL

Normal/reverse action:

Model FHE: Selectable by moving a jumper pin located on the electronics unit.

Model FKE: Selectable from HHC

Indication: Analog indicator or 4-digit LCD meter, as specified.

Burnout direction: Output hold
Output 21.6mA } selectable.
Output 3.8mA }

Model FHE: Unless otherwise specified, the output is in hold position.

Model FKE: Selectable from HHC

Loop-check output:

Model FHE: Transmitter can output constant signal of 4mA, 12mA, or 20mA if MODE SWITCH is set to the loop check mode.

Model FKE: Transmitter can be configured to provide constant signal 4mA or 20mA by HHC.

Temperature limit:

Ambient: - 40 to + 85°C

(- 20 to + 80°C for LCD indicator)

(- 40 to + 60°C for arrester option)

(- 10 to + 60°C for fluorinated oil fill transmitter)

For explosionproof units (flameproof or intrinsic safety), ambient temperature must be within the limits specified in each standard.

Process:

Fill fluid	Code in the 13th digit of "Code symbols"	Process temperature	Lower limit of static press
Fluorinated oil	W, A and D	-20 to 80°C	Atmospheric pressure
Silicone oil	H	-15 to 250°C	
	J	85 to 300°C	
	Y and G	-40 to 120°C	
	S	-15 to 250°C	
	T	85 to 300°C	2.7kPa abs (20.3mmHg abs)
	K	-15 to 150°C	0.13kPa abs (0.98mmHg abs)

Low pressure side process temperature is 120°C or lower.

Storage: - 40 to + 90°C

Humidity limit: 0 to 100% RH

Communication: (Model FKE only)

With HHC (Model FXW, consult Data Sheet No. EDS8-47), following information can be remotely displayed or reconfigured.

Items	Display	Set
Tag No.	v	v
Model No.	v	v
Serial No.	v	—
Engineering unit	v	v
Range limit	v	—
Measuring range	v	v
Damping	v	v
Output mode	v	v
Burnout direction	v	v
Input adjustment	v	v
Output adjust	—	v
Data	v	—
Self diagnoses	v	—
Printer	—	—
External switch lock	v	v

Performance specifications

Accuracy rating: (including linearity, hysteresis, and repeatability)

For spans greater than 1/10 of URL: $\pm 0.2\%$ of span
 For spans below 1/10 of URL (Model FKE only):

$$\pm \left(0.1 + 0.1 \frac{0.1 \times \text{URL}}{\text{Span}} \right) \% \text{ of span}$$

Linearity: 0.1% of calibrated span

Stability: $\pm 0.2\%$ of upper range limit (URL) for 6 months

Temperature effect:

Effects per 55°C change between the limits of -40°C and +85°C
 Zero shift: $\pm 0.8\%$ of URL
 Total effect: $\pm 1.5\%$ of URL

Static pressure effect:

Zero shift: $\pm 0.2\%$ of URL/1MPa(10 bar)
 Span shift: -0.2% of calibrated span for flange rating pressure
 Double the zero shift for material code (7th digit in "Code symbols") "H", "M", "T", "B", "L", "U", "P" and "R".

Overrange effect: Zero shift:

$\pm 0.3\%$ of URL for flange rating pressure
 Double the effects for material code "H", "M", "T", "B", "L", "U", "P" and "R".

Supply voltage effect:

Less than 0.05% of calibrated span per 10V

RFI effect:

Less than 0.2% of URL for the frequencies of 20 to 1000MHz and field strength 10 V/m when electronics covers on.
 (Classification: 2-abc: 0.2% span per SAMA PMC 33.1)

Step response: (without electrical damping)

Range code	Time constant	Dead time
"3"	0.55 s	approx. 0.3 s
"4" through "6"	0.3 s	

Mounting position effect:

Zero shift, less than 0.3kPa(30.6 mmH₂O) tilt in any plane. (No extension)

No effect on span.

This error can be corrected by adjusting zero.

(Double the effect for fluorinated fill sensors)

Dielectric strength:

500V AC, 50/60Hz 1 min., between circuit and earth (For the type with arrester, remove earthing plate.)

Insulation resistance:

More than 100M Ω at 500V DC (For the type with arrester, remove earthing plate)

Turn-on time: 4 sec

Physical specifications

Electrical connections:

G1/2, 1/2-14 NPT, Pg13.5, or M20 x 1.5 conduit, as specified.

Process connections:

LP side: 1/4-18 NPT or Rc1/4.

HP side: ANSI, DIN, or JIS raised face flange.

Refer to "Code symbols"

Process-wetted parts material (*1):

Material code (7th figure in "Code symbols")	LP side		HP side	
	Process cover	Diaphragm	Wetted sensor body	Diaphragm & flange face
W	316SS (*2)	Hastelloy-C	316SS	316(L)SS
V	316SS (*2)	316LSS	316SS	316(L)SS
H	316SS (*2)	Hastelloy-C	Hastelloy-C lining	Hastelloy-C
M	316SS (*2)	Monel	Monel lining	Monel
T	316SS (*2)	Tantalum	Tantalum lining	Tantalum
B	Hastelloy-C lining	Hastelloy-C	Hastelloy-C lining	Hastelloy-C
L	Monel lining	Monel	Monel lining	Monel
U	Tantalum lining	Tantalum	Tantalum lining	Tantalum
P	316SS (*2)	Titanium	Titanium lining	Titanium
R	316 SS (*2)	Zirconium	Zirconium lining	Zirconium

Notes : * (1) SS : Stainless steel

(2) SCS14 per JIS G 5121

Remark : Sensor O-rings: Viton for material code

"W", "V", "H", "M", and "T"

Teflon for material code "B", "L", and "U"

Non-wetted parts material:

Electronics housing: Low copper die-cast aluminum alloy (standard), finished with epoxy/polyurethane double coating, or 304SS, as specified.

Bolts and nuts: Cr-Mo alloy (standard) or 304SS

Fill fluid: Silicone oil (standard) or fluorinated oil (Daifloil)

Mounting flange: Carbon steel or 304SS, as specified

Environmental protection:

IEC IP67 and NEMA 4X

Flange mounting: See drawings

Mass(weight): Transmitter approximately 13kg without options.

Add; 0.8kg for indicator option

4.5kg for stainless steel housing option

1.0kg per 50mm extension of diaphragm

Optional features

- Indicator:** A plug-in turnable analog indicator (1.5% accuracy) can be housed in the electronics compartment or in the terminal box of the housing.
An optional 4 digits LCD meter is also available.
- Arrester:** A built-in arrester protects the electronics from lightning surges.
Not available with intrinsic safety approvals.
- Oxygen service:** Special cleaning procedures are followed throughout the process to maintain all process wetted parts oil-free.
The fill fluid is fluorinated oil.
- Chlorine service:** The fill fluid is fluorinated oil.
Not available with material code W, V, M and L.
- Degreasing:** Process-wetted parts are cleaned, but the fill fluid is standard silicone oil. Not for use for oxygen or chlorine measurement.
- Vacuum service:** Special silicone oil and filling procedure are applied.
See below figure.

ACCESSORIES

- Oval flanges:** (Model FFP, refer to Data Sheet No. EDS6-10)
Converts process connection to 1/2-14 NPT or to Rc1/2; in carbon steel or in 316 SS.
- Hand held communicator:** (Model FXW, refer to Data Sheet No. EDS 8-47)
- Communication module:** (Standard for model FKE)
When using this module for model FHE, remote setting function becomes available.
Remark: When the communication module is connected, the operation mode of external zero/span is changed from UP DOWN to one-push adjustment.

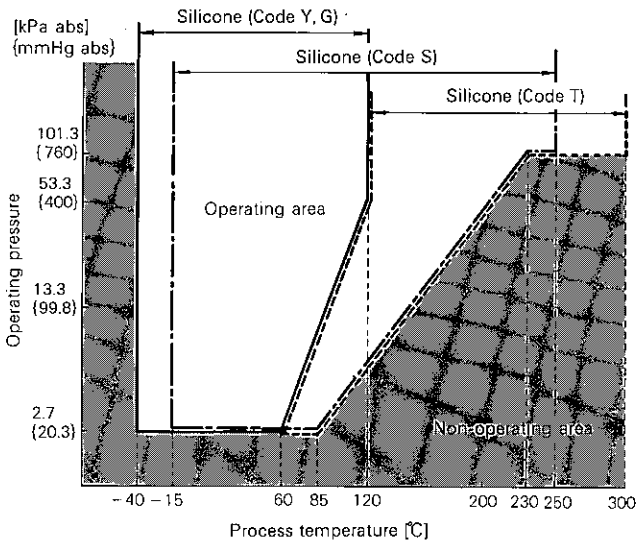

Fig. 1 Relation between process temperature and operating pressure

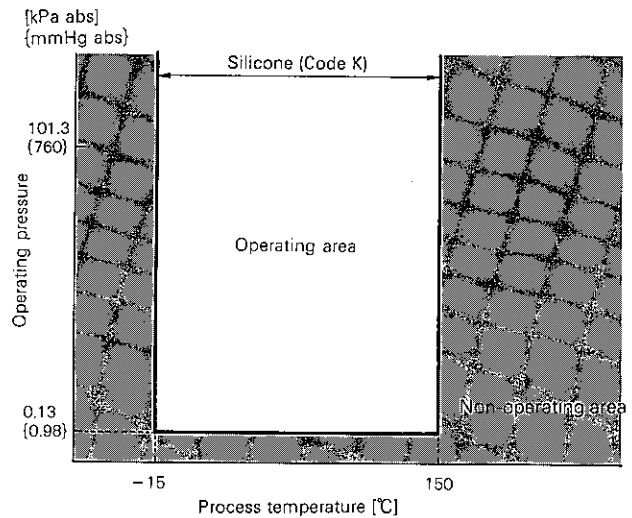
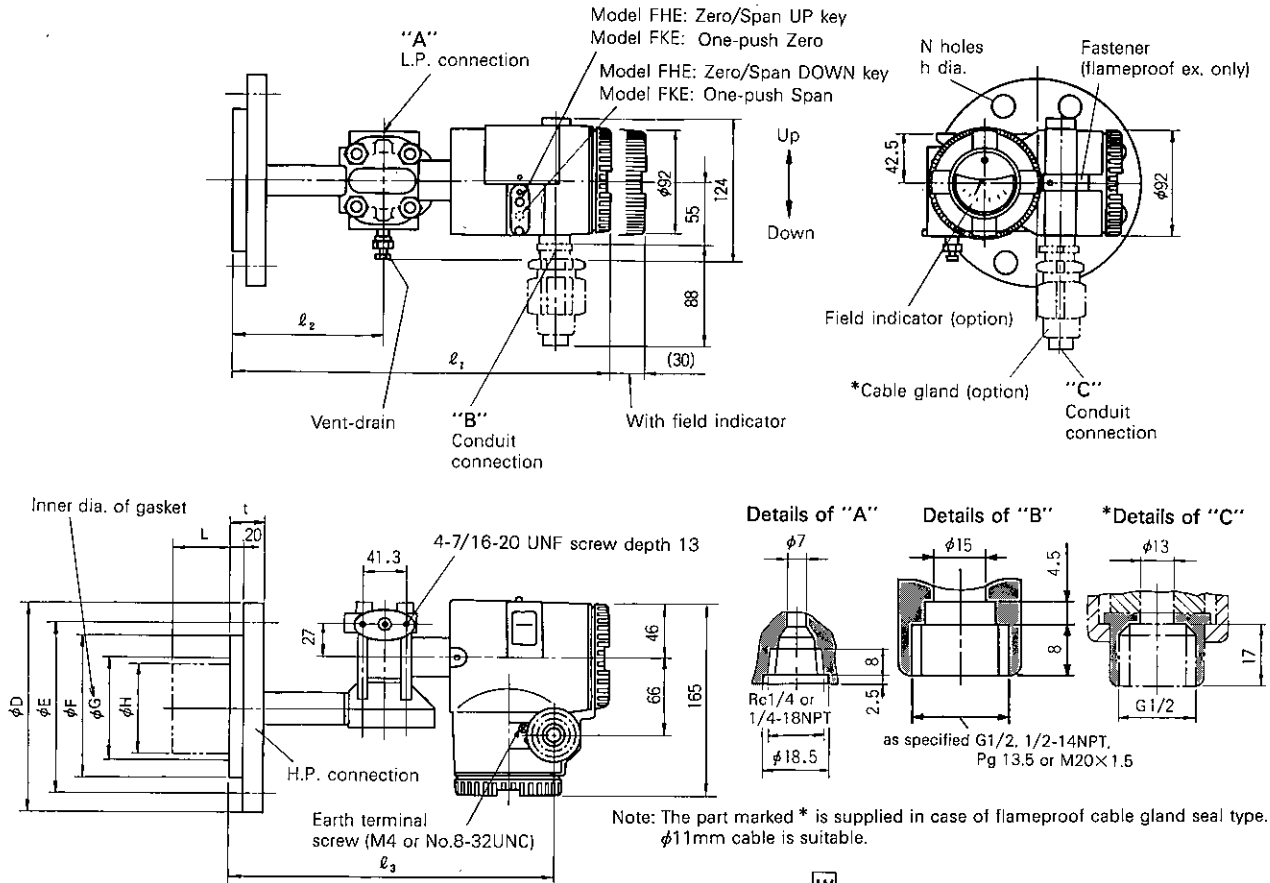

Fig. 2 Relation between process temperature and operating pressure

Customer tag: A stainless steel tag with customer tag data is wired to the transmitter.

OUTLINE DIAGRAM (Unit:mm)



W
V
H
M
T
P
R

ϕD	ϕE	ϕF	ϕG	ϕH	t	N- ϕh	Flange
185	150	126	100	73	38	8-19	JIS-10K-80A
210	175	151	103	96	38	8-19	JIS-10K-100A
210	170	126	100	73	48	8-23	JIS-30K-80A
240	195	151	103	96	52	8-25	JIS-30K-100A
191	152.5	126	100	73	44	4-20	ANSI/JPI-150LB-3B
229	190.5	151	103	96	44	8-20	ANSI/JPI-150LB-4B
210	168	126	100	73	49	8-23	ANSI/JPI-300LB-3B
254	200	151	103	96	52	8-23	ANSI/JPI-300LB-4B
200	160	126	100	73	44	8-18	DIN PN40 DN80
220	180	151	103	96	40	8-18	DIN PN16 DN100

Extension length L (mm)	l_1	l_2	l_3
0	351	147	303
50	345	141	297
100			
150			
200			

<Optional stainless steel tag>

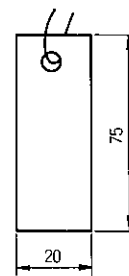

CONNECTION DIAGRAM

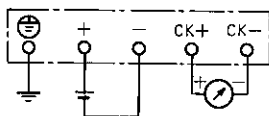

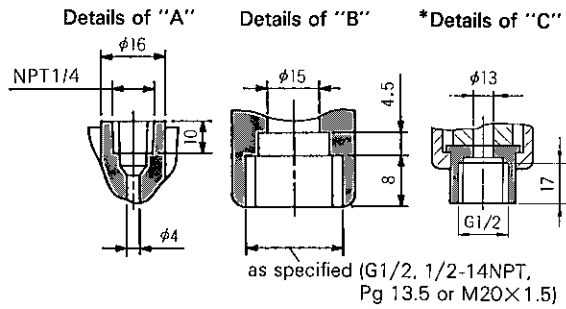
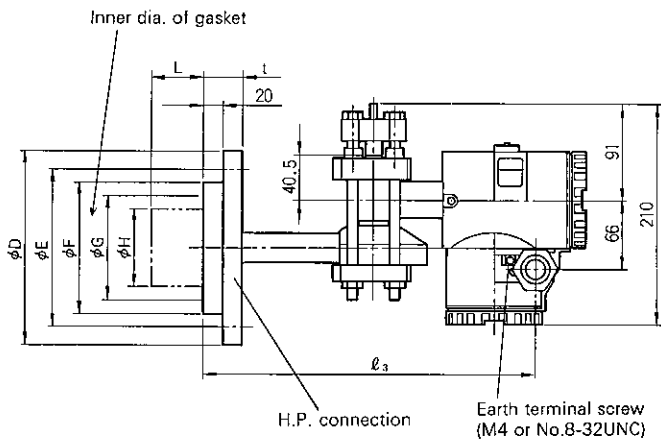
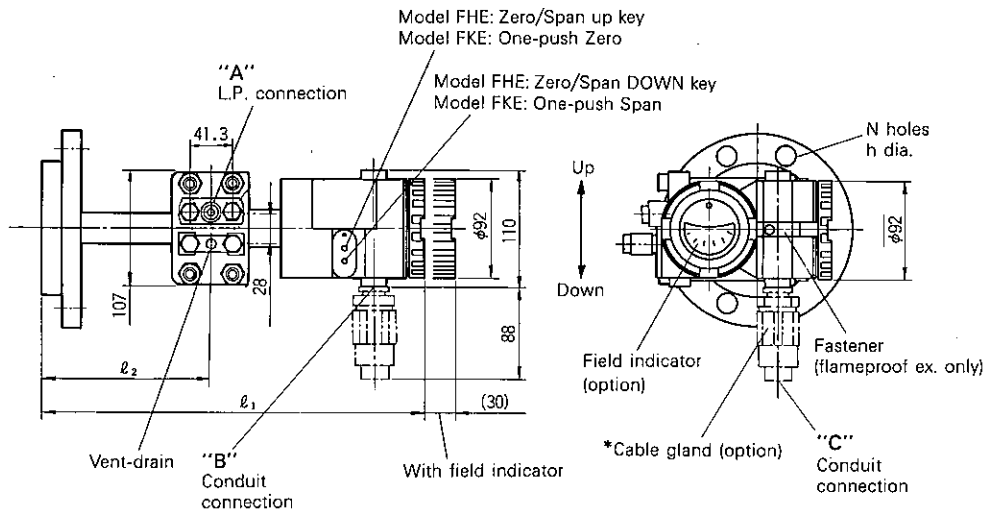

Note: The part marked * is supplied in case of flameproof cable gland seal type. $\phi 11$ mm cable is suitable.



ϕD	ϕE	ϕF	ϕG	ϕH	t	N- ϕ	Flange
185	150	126	100	73	38	8-19	JIS-10K-80A
210	175	151	103	96	38	8-19	JIS-10K-100A
210	170	126	100	73	48	8-23	JIS-30K-80A
240	195	151	103	96	52	8-25	JIS-30K-100A
191	152.5	126	100	73	44	4-20	ANSI/JPI-150LB-3B
229	190.5	151	103	96	44	8-20	ANSI/JPI-150LB-4B
210	168	126	100	73	49	8-23	ANSI/JPI-300LB-3B
254	200	151	103	96	52	8-23	ANSI/JPI-300LB-4B
200	160	126	100	73	44	8-18	DIN PN40 DN80
220	180	151	103	96	40	8-18	DIN PN16 DN100

Extension length L [mm]	ℓ_1	ℓ_2	ℓ_3
0	351	147	303
50	345	141	297
100			
150			
200			

CONNECTION DIAGRAM

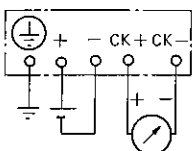

CODE SYMBOLS

1 2 3 4 5 6 7 8 9 10 11 12 13																
							1						Description			
F	H	E											Type			
F	K	E											4 to 20mA, Traditional type			
													4 to 20mA with digital signal, Smart type			
													Connections			
													Process connection	Oval flange screw	Conduit connection	
S													Rc1/4	7/16-20UNF	G 1/2	
T													1/4-18NPT	7/16-20UNF	1/2-14NPT	
V													1/4-18NPT	M10	Pg 13.5	
W													1/4-18NPT	M10	M20 x 1.5	
X													1/4-18NPT	7/16-20UNF	pg 13.5	
													Mounting flange			
													Material	Size and rating		
0													304SS	JIS 10K 80A		
1												JIS 10K 100A				
2												JIS 30K 80A				
3												JIS 30K 100A				
4												ANSI/JPI 150LB 3B				
5												ANSI/JPI 150LB 4B				
6												ANSI/JPI 300LB 3B				
7												ANSI/JPI 300LB 4B				
8												DIN PN40 DN80				
9												DIN PN16 DN100				
A												Carbon steel	JIS 10K 80A			
B													JIS 10K 100A			
C													JIS 30K 80A			
D													JIS 30K 100A			
E													ANSI/JPI 150LB 3B			
F													ANSI/JPI 150LB 4B			
G													ANSI/JPI 300LB 3B			
H													ANSI/JPI 300LB 4B			
J													DIN PN40 DN80			
K													DIN PN16 DN100			
													Span limit [kPa] (mmH ₂ O)			
													Model FHE	Model FKE		
3													3.2 .. 32 (320 3200)	0.32 .. 32 (32 3200)		
4													6.4 .. 64 (640 6400)	0.64 .. 64 (64 6400)		
5													13 ... 130 (1300 ... 13000)	1.3 .. 130 (130 ... 13000)		
6													50 ... 500 (5000 ... 50000)	5 500 (500 ... 50000)		
													Material			
													LP side		HP side	
													Process cover	Diaphragm	Wetted sensor body	Diaphragm & flange face
W													316SS	Hastelloy-C	316SS	316(L)SS
(*) V													316SS	316LSS	316SS	316(L)SS
H													316SS	Hastelloy-C	Hastelloy-C lining	Hastelloy-C
M													316SS	Monel	Monel lining	Monel
T													316SS	Tantalum	Tantalum lining	Tantalum
B													Hastelloy-C lining	Hastelloy-C	Hastelloy-C lining	Hastelloy-C
L													Monel lining	Monel	Monel lining	Monel
U													Tantalum lining	Tantalum	Tantalum lining	Tantalum
P													316SS	Titanium	Titanium	Titanium
(**) R													316SS	Zirconium	Zirconium	Zirconium

Notes: * (1) Material code R; Measuring span code "6" (6th digit) is not available.

(2) When measuring span code (6th digit) is "6", the low pressure side seal diaphragm is made of Hastelloy-C.

1	2	3	4	5	6	7	8	9	10	11	12	13
F	K	E					1					
F	K	E					1					

		Description		
		Indicator and arrester		
		Indicator	Arrester (*)	
A		None	None	
B		Analog, 0 to 100% linear scale	None	
D		Analog, custom scale	None	
E		None	Yes	
F		Analog, 0 to 100% linear scale	Yes	
H		Analog, custom scale	Yes	
L		Digital, 0 to 100%	None	
P		Digital, custom scale	None (Model FKE only)	
Q		Digital, 0 to 100%	Yes	
S		Digital, custom scale	Yes (Model FKE only)	
		Approvals for hazardous locations		
A		None (for ordinary locations)		
B		JIS, Flameproof (Conduit seal)		
C		JIS, Flameproof (Cable gland seal)		
D		FM, Flameproof (or explosionproof)		
E		CSA, Flameproof (or explosionproof)		
M		BASEEFA, Flameproof (Conduit seal)		
N		BASEEFA, Flameproof (Cable gland seal. Conduit connection G1/2 only)		
R		SAA, Flameproof (Conduit seal)		
S		SAA, Flameproof (Cable gland seal. Conduit connection G 1/2 only)		
G		JIS, Intrinsic safety		
H		FM, Intrinsic safety and nonincendive		
J		CSA, Intrinsic safety and nonincendive		
K		BASEEFA, Intrinsic safety		
P		BASEEFA, Intrinsic safety and Type N		
T		SAA, Intrinsic safety		
V		NEPSI, Flameproof (Conduit seal)		
W		NEPSI, Intrinsic safety)		
		Diaphragm extension [mm]		
		Extension [mm]	Applicable material code	
Y		0	Any	
A		50	"W" or "V" only	
B		100		
C		150		
D		200		
E		50	"H" or "B" only	
F		100		
G		150		
H		200		
		Stainless steel parts		
		SS bolt/nut for LP cover	SS tag plate	SS elec. housing
Y		None	None	None
A		Yes	None	None
B		None	Yes	None
C		None	None	Yes
D		Yes	Yes	None
E		None	Yes	Yes
F		Yes	None	Yes
G		Yes	Yes	Yes
		Special applications and fill fluid		
		Treatment	Fill fluid	
Y		None (standard)	Silicone oil	
W		None (standard)	Fluorinated oil	
G		Degreasing	Silicone oil	
A		Oxygen service	Fluorinated oil (Material code W, V only)	
D		Chlorine service	Fluorinated oil (Material code H, T, B and U)	
H		None	Silicone oil (for high temp. 250°C)	
J		None	Silicone oil (for high temp. 300°C)	
S		None	Silicone oil (for high temp., vacuum) (250°C)	
T		None	Silicone oil (for high temp., vacuum) (300°C)	
K		None	Silicone oil (for high temp., high vacuum)	

Note: * Arrester option is not available when intrinsic safety is specified.

Fuji Electric Co., Ltd.

Head office

12-1 Yurakucho 1-chome, Chiyoda-ku, Tokyo, 100 Japan
 Phone: Tokyo 3211-7111
 Telex: J22331 FUJIELEA or FUJIELEB

Instrumentation & Control Div.

No.1, Fuji-machi, Hino-city, Tokyo 191 Japan
 Phone: 0425-85-6200
 Fax: 0425-85-6188