

Customer Information Sheet

DRAWING No.: M22-30400XX

SHEET 2 OF 2

IF IN DOUBT - ASK

©

NOT TO SCALE

THIRD ANGLE PROJECTION

ALL DIMENSIONS IN mm

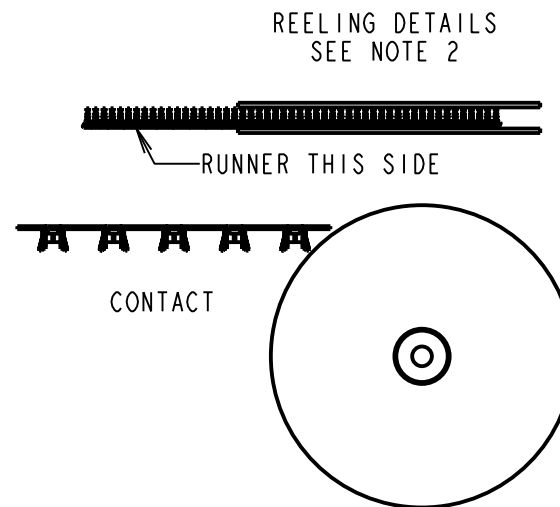
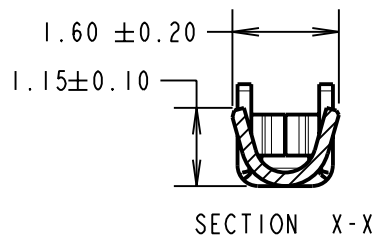
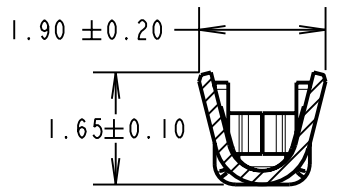
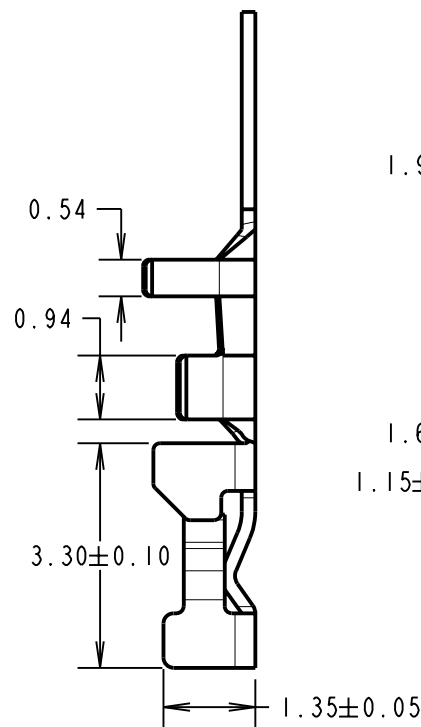
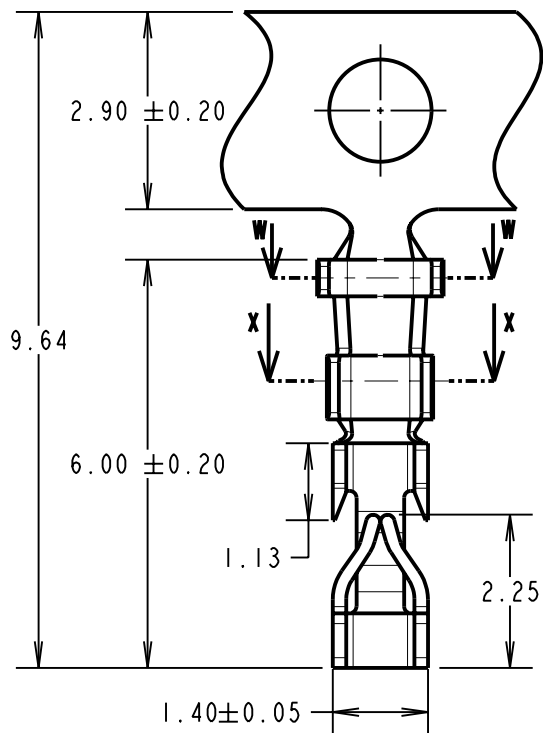

- NOTES:
1. TO BE USED WITH CRIMP MOULDINGS M22-301XX00 OR M22-302XX00.
 2. REELED TO SUIT L.H. LOADING CRIMPING MACHINE ZGP-240/110, OPEN FORM OF CRIMP TO BE UNDERNEATH ON REEL.
 3. FOR HAND CRIMPING ONTO WIRE, USE HAND TOOL Z22-020 (INSTRUCTION SHEET IS-05), STRIP WIRE BY 1.0 - 1.5mm BEFORE CRIMPING.
 4. SUITABLE FOR WIRE GAUGES 24-30 AWG.
 5. NUMBER OF CONTACTS PER REEL = 10K.

ORDER CODE:
M22-30400XX
 FINISH: _____
 42 = GOLD
 46 = 100% TIN

RA	9	09.06.10	10764
NAME	ISS.	DATE	C/NOTE
APPROVED:		R. ADDE	
CHECKED:		W. J. BOURNE	
DRAWN:		W. J. BOURNE	
CUSTOMER REF.:			
ASSEMBLY DRG:			

HARWIN

HARWIN USA TEL: 603 893 5376 FAX: 603 893 5396 mis@harwin.com	HARWIN Europe (UK) TEL: 023 9231 4545 FAX: 023 9231 4590 mis@harwin.co.uk	HARWIN Asia TEL: +65 6 779 4909 FAX: +65 6 779 3868 mis@harwin.com.sg
--	--	--

THIS DRAWING AND ANY INFORMATION OR DESCRIPTIVE MATTER SET OUT HEREON ARE CONFIDENTIAL AND COPYRIGHT PROPERTY OF THE HARWIN GROUP AND MUST NOT BE DISCLOSED, LOANED, COPIED OR USED FOR MANUFACTURING, TENDERING OR FOR ANY OTHER PURPOSE WITHOUT THEIR WRITTEN PERMISSION.

TOLERANCES
 X. = ±1mm
 X.X = ±0.25mm
 X.XX = ±0.10mm
 X.XXX = ±0.01mm
 ANGLES = ±5°
 UNLESS STATED

MATERIAL:
 PHOSPHOR BRONZE
 FINISH: SEE ORDER CODE
 S/AREA: mm²

TITLE:
 REELED CRIMP CONTACT
 DRAWING NUMBER:
M22-30400XX
 SHT 2 OF 2